

PLAN

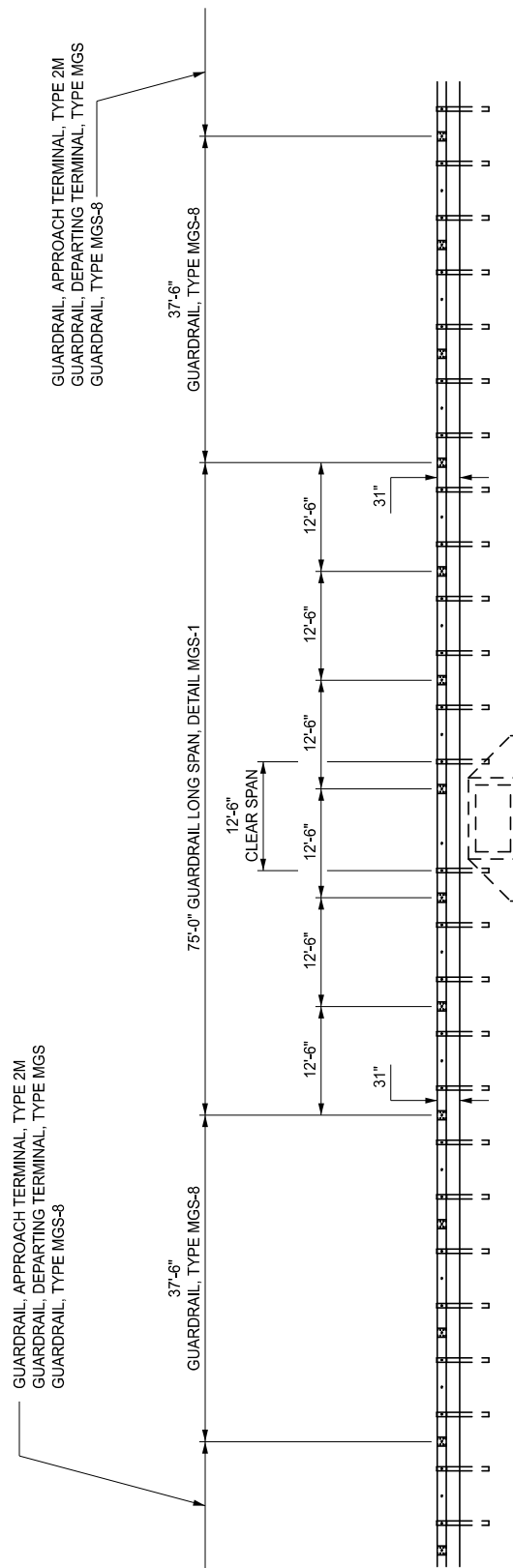

ELEVATION
GUARDRAIL LONG SPAN, DETAIL MGS-1

APPROVED BY: _____
DIRECTOR, BUREAU OF FIELD SERVICES

APPROVED BY: _____
DIRECTOR, BUREAU OF DEVELOPMENT



DEPARTMENT DIRECTOR
BRADLEY C. WIEFERICH, PE

STANDARD PLAN FOR
GUARDRAIL LONG SPAN INSTALLATIONS

(SPECIAL DETAIL)
FHWA APPROVAL

08/23/2022
PLAN DATE

R-72-D

SHEET
1 OF 6

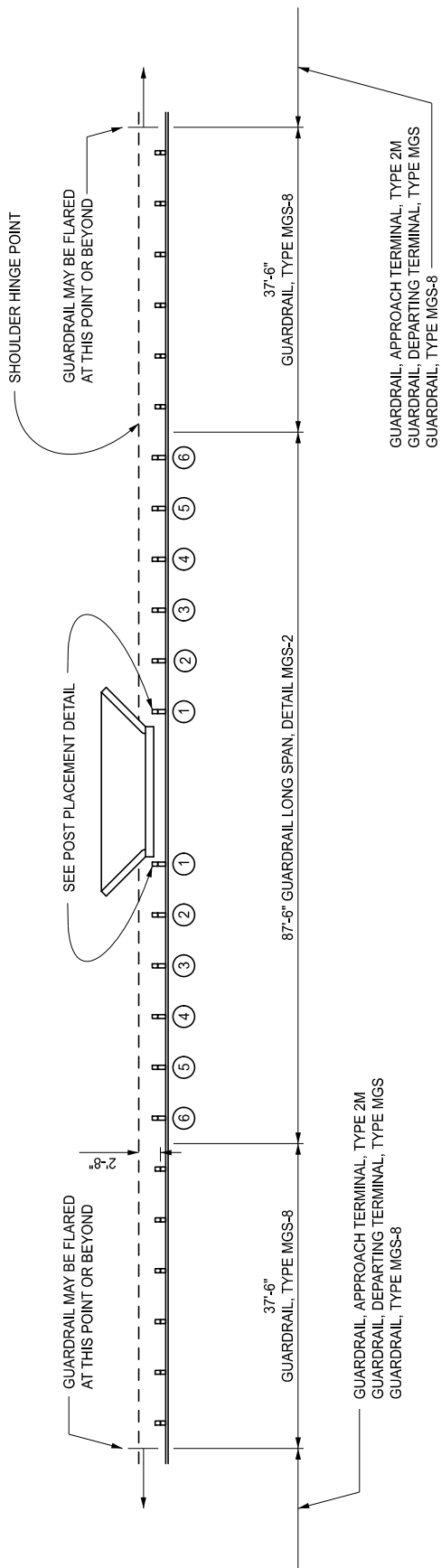

PLAN

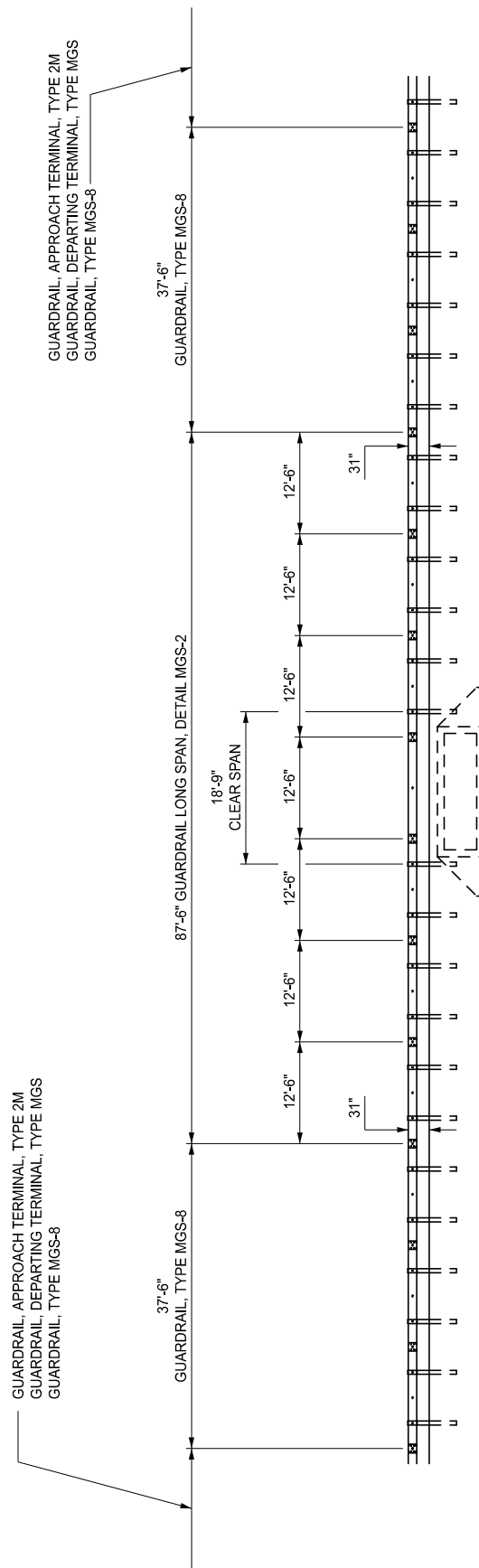

ELEVATION

GUARDRAIL LONG SPAN, DETAIL MGS-2

MDOT
Michigan Department of Transportation

DEPARTMENT DIRECTOR
BRADLEY C. WIEFERICH, PE

STANDARD PLAN FOR GUARDRAIL LONG SPAN INSTALLATIONS		R-72-D	SHEET 2 OF 6
(SPECIAL DETAIL) FHWA APPROVAL	08/23/2022 PLAN DATE		

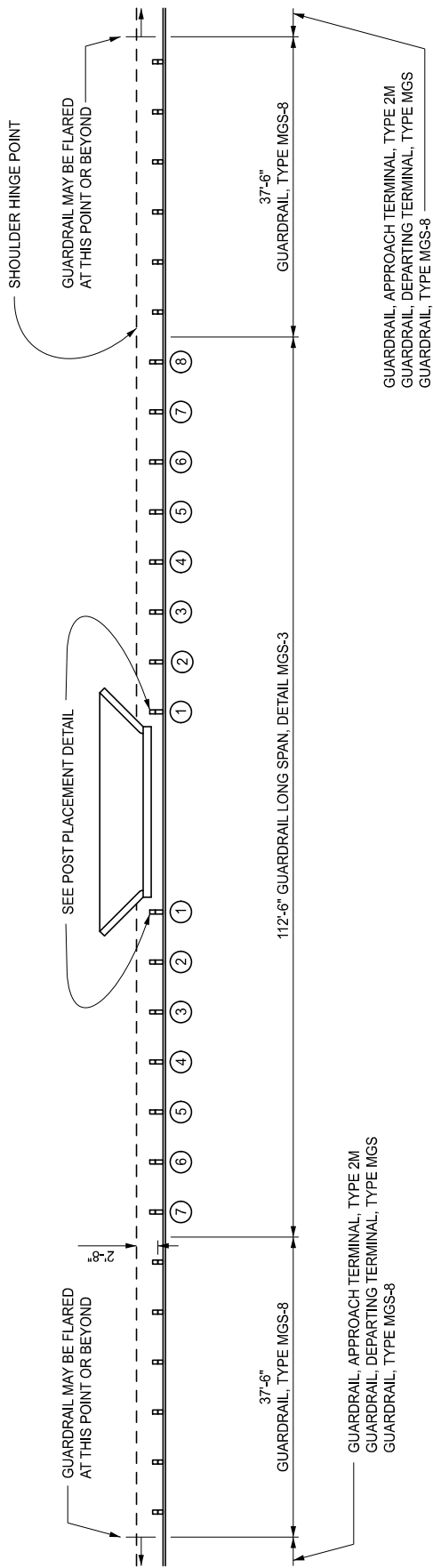

PLAN

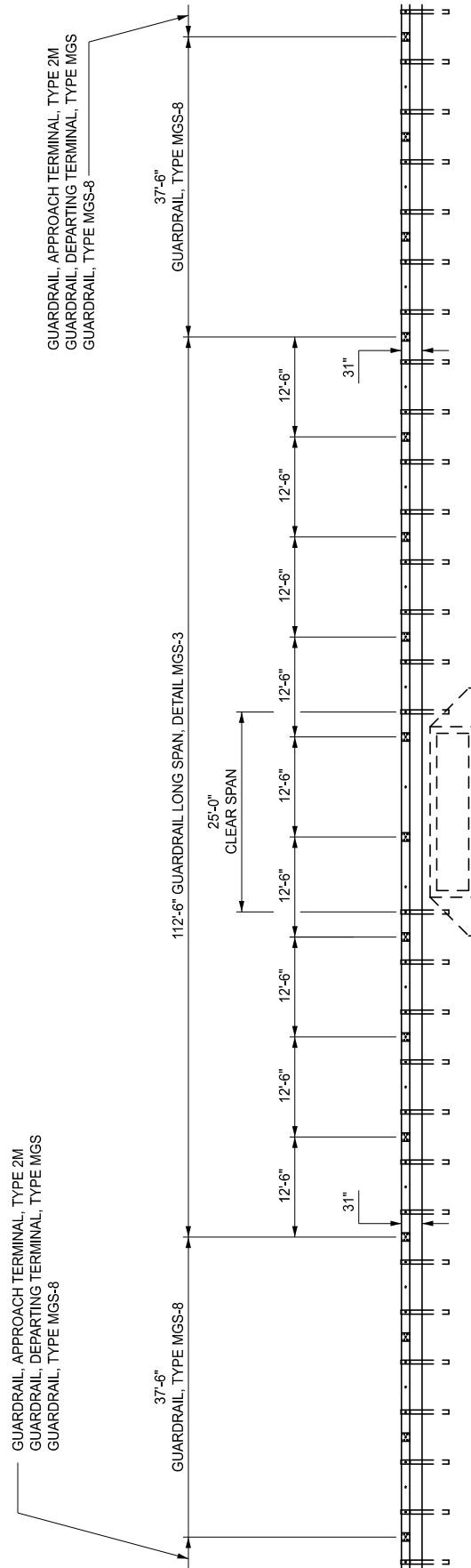

ELEVATION

GUARDRAIL LONG SPAN, DETAIL MGS-3



DEPARTMENT DIRECTOR
BRADLEY C. WIEFERICH, PE

STANDARD PLAN FOR
GUARDRAIL LONG SPAN INSTALLATIONS

(SPECIAL DETAIL)
FHWA APPROVAL

08/23/2022
PLAN DATE

R-72-D

SHEET
3 OF 6

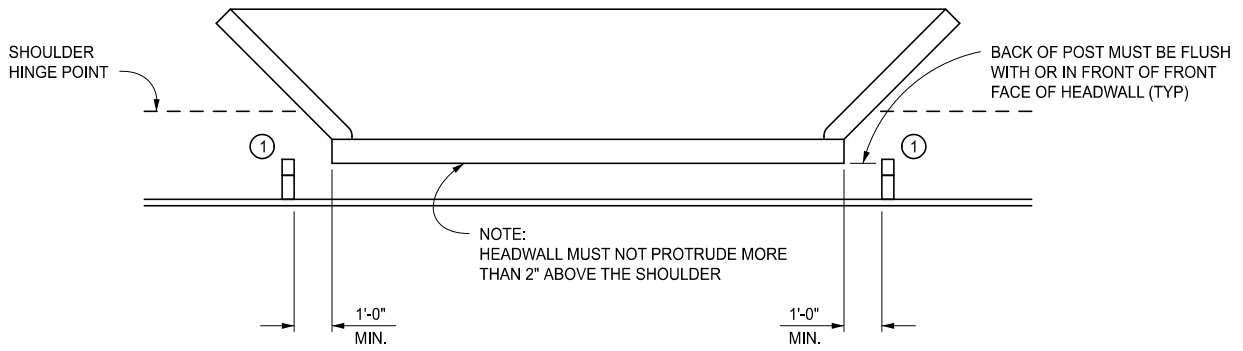

POST PLACEMENT DETAIL

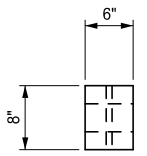

PLAN

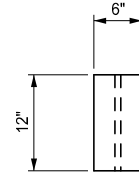

TOP

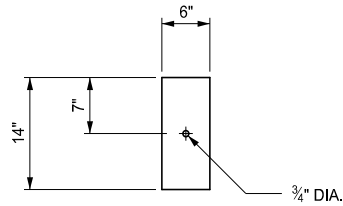

FRONT

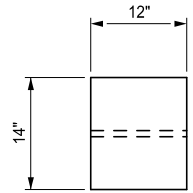

SIDE

MGS 12" OFFSET BLOCK
FOR USE ON WOOD POSTS

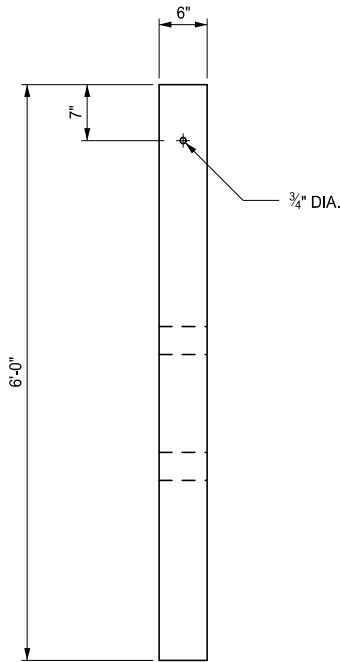

FRONT

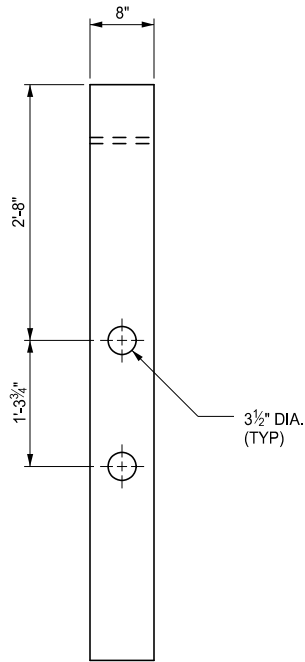

SIDE

MGS-CRT POST

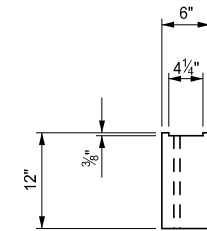

TOP

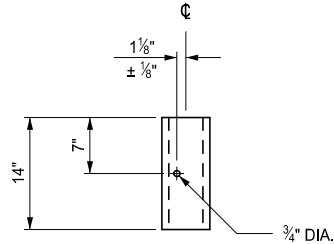

FRONT

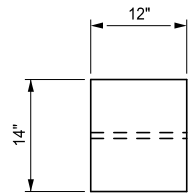

SIDE

MGS 12" OFFSET BLOCK
FOR USE ON STEEL POSTS



DEPARTMENT DIRECTOR
BRADLEY C. WIEFERICH, PE

STANDARD PLAN FOR
GUARDRAIL LONG SPAN INSTALLATIONS

(SPECIAL DETAIL)
FHWA APPROVAL

08/23/2022
PLAN DATE

R-72-D

SHEET
4 OF 6

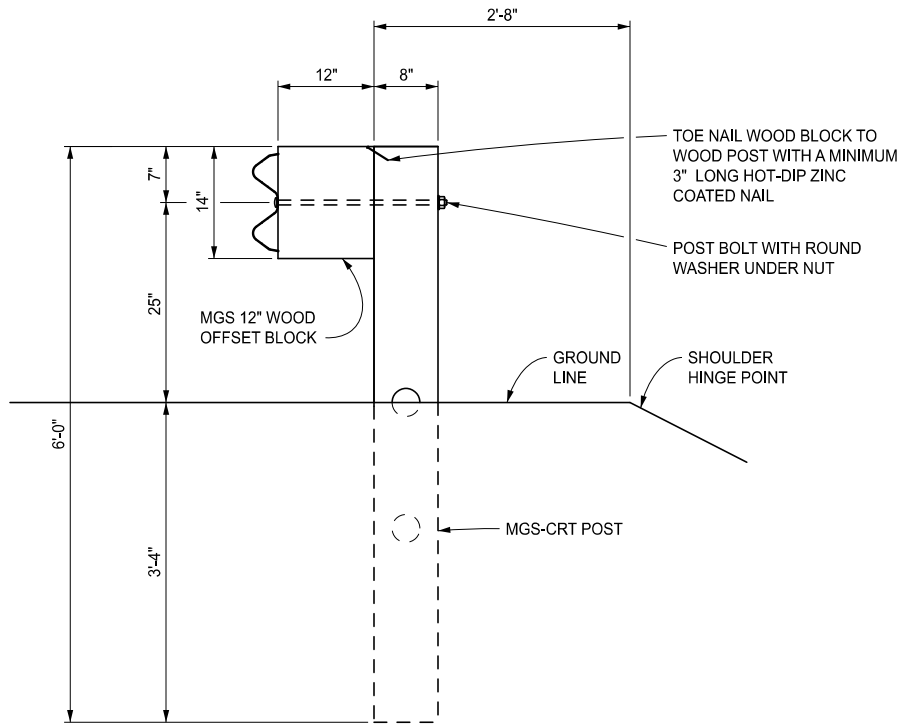

POST 1 THROUGH 3 DETAIL
 GUARDRAIL LONG SPAN DETAILS MGS-1, MGS-2, & MGS-3

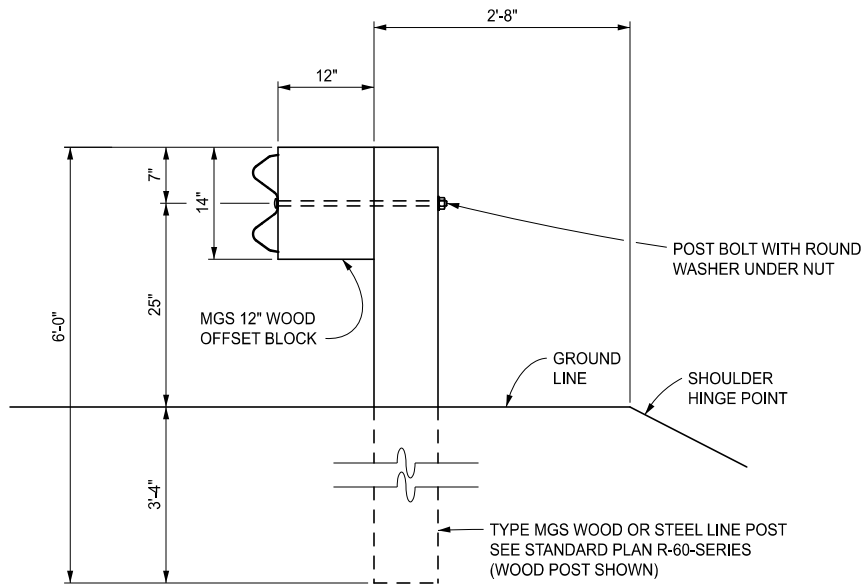

POST 4 THROUGH 6 DETAIL
 GUARDRAIL LONG SPAN DETAILS MGS-1 & MGS-2

POST 4 THROUGH 8 DETAIL
 GUARDRAIL LONG SPAN DETAIL MGS-3

NOTES:

ALL POSTS, OFFSET BLOCKS, BEAM ELEMENTS, AND HARDWARE (INCLUDING BOLTS, NUTS, AND WASHERS) SHALL BE ACCORDING TO THE STANDARD SPECIFICATIONS FOR CONSTRUCTION AND STANDARD PLAN R-60-SERIES, WHERE APPLICABLE, EXCEPT WHERE NOTED ON THIS STANDARD.

THE GUARDRAIL MODIFICATIONS DETAILED ON THIS STANDARD SHOULD ONLY BE USED WHERE 6'-3" POST SPACING AND POST EMBEDMENT CANNOT BE MET.

IF USE OF THIS DESIGN WOULD INTERFERE WITH THE POST SPACING WITHIN A GUARDRAIL BRIDGE ANCHORAGE AS SPECIFIED ON STANDARD PLAN R-67-SERIES, OTHER OPTIONS SHOULD BE INVESTIGATED AND USED.



DEPARTMENT DIRECTOR
BRADLEY C. WIEFERICH, PE

STANDARD PLAN FOR
GUARDRAIL LONG SPAN INSTALLATIONS

(SPECIAL DETAIL)
FHWA APPROVAL

08/23/2022
PLAN DATE

R-72-D

SHEET
6 OF 6