

**MDOT**  
Michigan Department of Transportation

PREPARED BY  
DESIGN DIVISION

DRAWN BY: B.L.T.

CHECKED BY: W.K.P.

DEPARTMENT DIRECTOR  
Paul C. Ajegba

APPROVED BY: Gregg Brunner, P.E. Gregg Brunner  
DIRECTOR, BUREAU OF FIELD SERVICES  
Oct 14 2021 12:33 PM

APPROVED BY: Bradley C. Wiefersich Bradley C. Wiefersich  
DIRECTOR, BUREAU OF DEVELOPMENT  
Oct 14 2021 11:02 AM

MICHIGAN DEPARTMENT OF TRANSPORTATION  
BUREAU OF DEVELOPMENT STANDARD PLAN FOR

**LOAD TRANSFER ASSEMBLIES  
FOR TRANSVERSE JOINTS**

|                               |                        |        |                 |
|-------------------------------|------------------------|--------|-----------------|
| 4-7-2022<br>F.H.W.A. APPROVAL | 10-1-2021<br>PLAN DATE | R-40-I | SHEET<br>1 OF 4 |
|-------------------------------|------------------------|--------|-----------------|

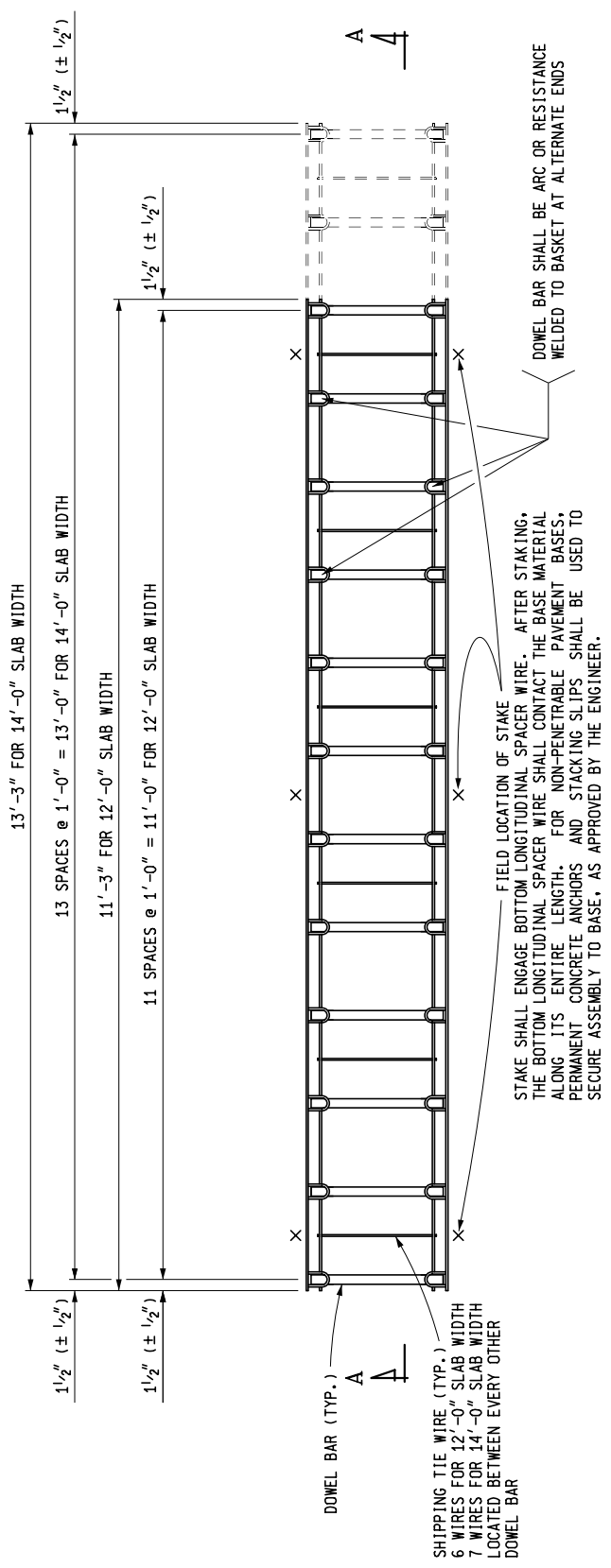

**PLAN VIEW OF CONTRACTION JOINT ASSEMBLY**

NOTE: SHIPPING TIE WIRES MAY BE LOCATED ABOVE OR BELOW TOP LONGITUDINAL SPACING WIRES.



**SECTION A-A**

|  |                        |                                    |
|--|------------------------|------------------------------------|
| MICHIGAN DEPARTMENT OF TRANSPORTATION<br>BUREAU OF DEVELOPMENT STANDARD PLAN FOR |                        |                                    |
| <h2 style="margin: 0;">LOAD TRANSFER ASSEMBLIES<br/>FOR TRANSVERSE JOINTS</h2>   |                        |                                    |
| 4-7-2022<br>F.H.W.A. APPROVAL  | 10-1-2021<br>PLAN DATE | <h1 style="margin: 0;">R-40-I</h1> |
|  |                        | SHEET<br>2 OF 4                    |

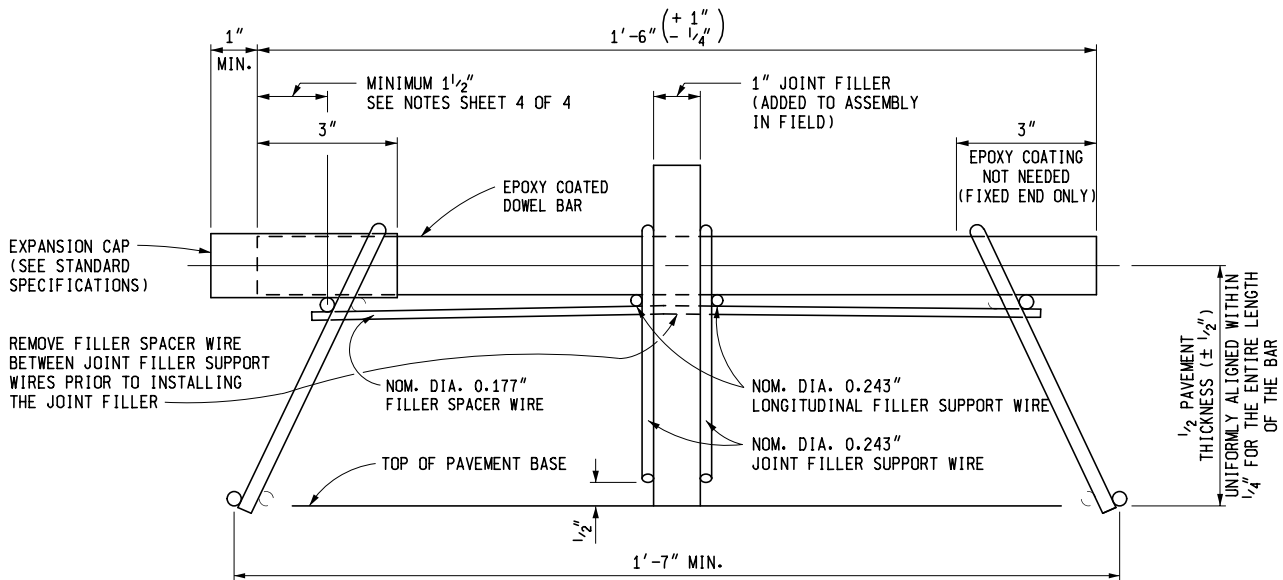

**END VIEW OF EXPANSION JOINT ASSEMBLY**

NOTE: FILLER SPACER WIRE MAY BE LOCATED ABOVE OR BELOW TOP LONGITUDINAL SPACER WIRES

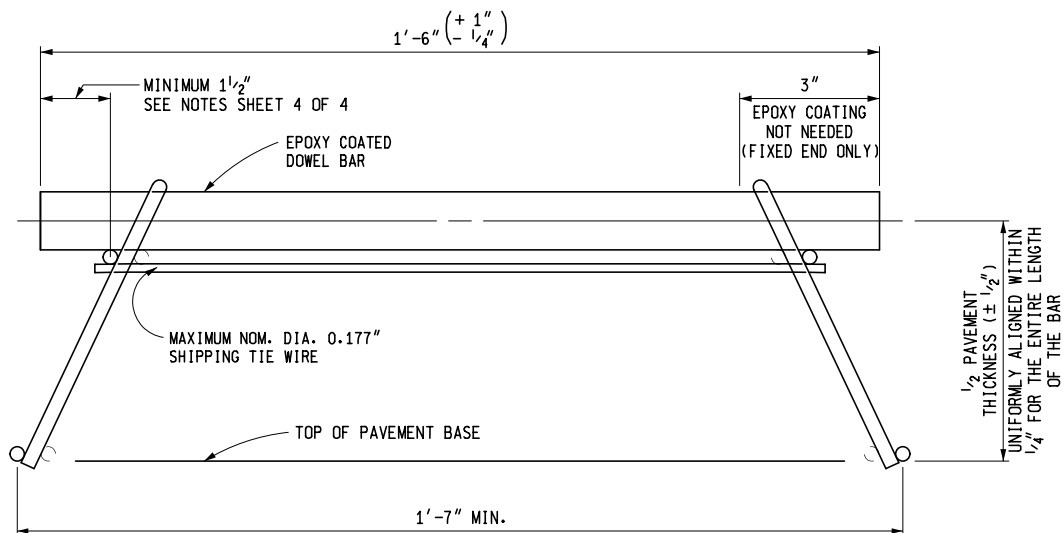

**END VIEW OF CONTRACTION JOINT ASSEMBLY**

NOTE: SHIPPING TIE WIRE MAY BE LOCATED ABOVE OR BELOW TOP LONGITUDINAL SPACER WIRES

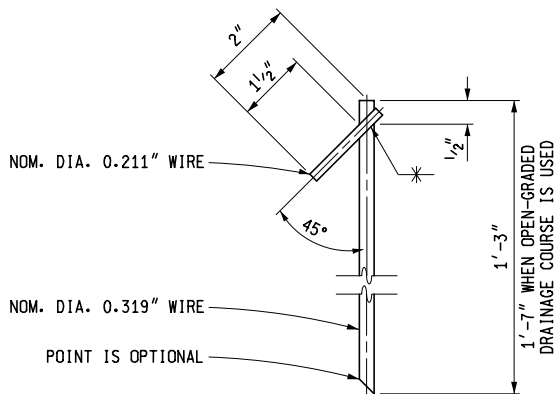

**STAKE DETAIL**

A SINGLE WIRE MAY BE USED IN LIEU OF STAKE DETAIL SPECIFIED PROVIDED A NOM. DIA. 0.319" WIRE IS USED AND BENT INTO A HOOK AT TOP END TO CONFORM TO DETAIL

MICHIGAN DEPARTMENT OF TRANSPORTATION  
BUREAU OF DEVELOPMENT STANDARD PLAN FOR

**LOAD TRANSFER ASSEMBLIES  
FOR TRANSVERSE JOINTS**

|                               |                        |        |                 |
|-------------------------------|------------------------|--------|-----------------|
| 4-7-2022<br>F.H.W.A. APPROVAL | 10-1-2021<br>PLAN DATE | R-40-I | SHEET<br>3 OF 4 |
|-------------------------------|------------------------|--------|-----------------|

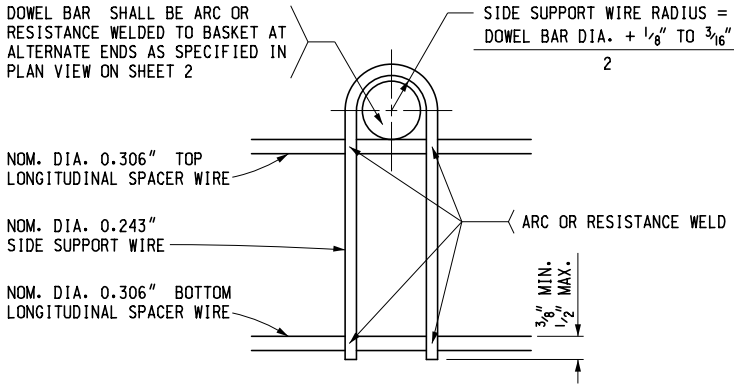

**SIDE SUPPORT WIRE DETAIL  
U - LEG OPTION**

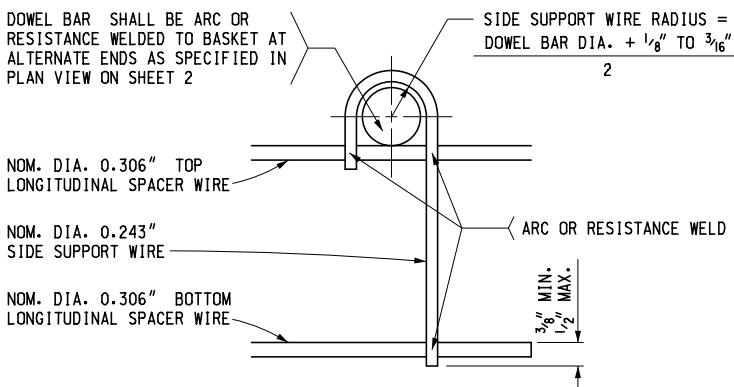

**SIDE SUPPORT WIRE DETAIL  
J - LEG OPTION**

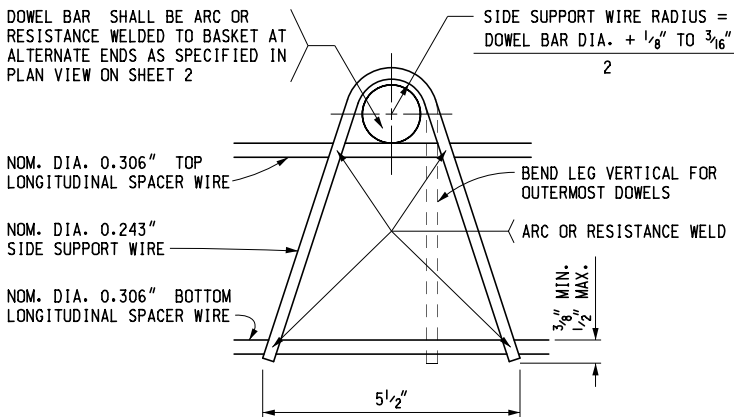

**SIDE SUPPORT WIRE DETAIL  
V - LEG OPTION**

**NOTES:**

LOAD TRANSFER ASSEMBLIES SHALL BE PLACED AT RIGHT ANGLES TO THE PAVEMENT CENTERLINE.

THE SIDE SUPPORT WIRE (U-LEG, J-LEG OR V-LEG) MAY BE INSTALLED ON EITHER THE INSIDE OR THE OUTSIDE OF THE LONGITUDINAL SPACER WIRES. THE DIMENSION FROM THE END OF THE DOWEL BAR TO THE CENTER OF THE TOP LONGITUDINAL SPACER WIRE SHALL BE A MINIMUM OF 1 1/2\".

**WIRES:**

ALL WIRES SPECIFIED (EXCEPT SHIPPING TIE WIRES) ARE MINIMUM NOMINAL SIZES ALLOWED. (DO NOT EXCEED THE MAXIMUM NOMINAL DIAMETER OF 0.177\" FOR SHIPPING TIE WIRES.)

ALL WIRES SHALL CONFORM TO THE CURRENT SPECIFICATIONS FOR CARBON STEEL WIRE FOR GENERAL USE, A.S.T.M. DESIGNATION A-853, GRADE 1008 OR GREATER. UNLESS OTHERWISE SPECIFIED, MINIMUM TENSILE STRENGTH REQUIREMENTS SHALL BE 60 ksi.

ALL WIRE INTERSECTIONS ARE TO BE ARC OR RESISTANCE WELDED.

STAKES TYPICALLY APPLIED AT WORKING ENDS OF DOWELS WITH SUFFICIENT INSTALLATIONS TO PREVENT UNIT FROM OVERTURNING UNDER LOAD.

DO NOT CUT FILLER SPACER WIRES AFTER THE LOAD TRANSFER ASSEMBLY IS SET IN PLACE.

**DOWEL BARS:**

DOWEL BARS ARE TO BE ACCORDING TO THE STANDARD SPECIFICATIONS FOR CONSTRUCTION.

EPOXY COATED DOWEL BARS ARE TO BE FACTORY COATED WITH A VISIBLE COATING OF AN APPROVED BOND RELEASE AGENT, UNIFORMLY APPLIED BY DIPPING AND WITHOUT EXCESSIVE DRIPS OR THICKNESS IN SUCH A THICKNESS THAT ITS PRESENCE CAN BE READILY IDENTIFIED.

METAL EXPANSION CAPS MUST BE ENTIRELY CLOSED AT ENDS BY CRIMPING. PLASTIC CAPS MUST HAVE A POSITIVE STOP. DO NOT DRIVE CAPS BEYOND THEIR STOP. EXPANSION CAPS MUST HAVE A SUITABLE STOP TO ENSURE THAT THE END OF THE CAP MAINTAINS A DISTANCE OF 1\" (EXPANSION) FROM THE END OF THE DOWEL DURING CONCRETE PLACEMENT.

DOWEL BARS SHALL BE COATED WITH EPOXY COATING ACCORDING TO THE STANDARD SPECIFICATIONS FOR CONSTRUCTION. CUT ENDS ARE NOT REQUIRED TO BE COATED.

| DOWEL BAR DIAMETER | PAVEMENT THICKNESS |
|--------------------|--------------------|
| 1"                 | 6" - LESS THAN 8"  |
| 1 1/4"             | 8" - 10"           |
| 1 1/2"             | GREATER THAN 10"   |

DOWEL BARS SHALL BE ALIGNED PARALLEL TO EACH OTHER IN THE ASSEMBLY ON 1'-0" ( $\pm 1/2$ ") CENTERS.

AFTER THE LOAD TRANSFER ASSEMBLY IS SET IN PLACE, DOWEL BARS SHALL REMAIN ALIGNED (PARALLEL) WITH EACH OTHER IN THE VERTICAL AND HORIZONTAL PLANES OF THE PAVEMENT TO WITHIN 1/4\" FOR THE ENTIRE LENGTH OF THE BAR.

DOWEL BARS SHALL BE PLACED AT MID DEPTH OF THE SLAB UNIFORMLY ALIGNED WITHIN 1/4\" FOR THE ENTIRE LENGTH OF THE BAR.

FOR PAVEMENTS WITH VARIABLE THICKNESS TRANSVERSLY ACROSS THE SLAB, THE TOP AND BOTTOM SURFACES OF THE DOWEL BAR SHALL BE WITHIN THE MIDDLE 1/3 OF THE PAVEMENT THICKNESS, AS APPROVED BY THE ENGINEER.

MICHIGAN DEPARTMENT OF TRANSPORTATION  
BUREAU OF DEVELOPMENT STANDARD PLAN FOR

**LOAD TRANSFER ASSEMBLIES  
FOR TRANSVERSE JOINTS**

4-7-2022  
F.H.W.A. APPROVAL

10-1-2021  
PLAN DATE

R-40-I

SHEET  
4 OF 4