

NOTE:
 ABOVE ILLUSTRATION SHOWS ONE LEG OF FENCE CONSTRUCTION AT FENCE CORNER OR END OF FENCE RUN. THE CONTINUOUS LEG TO BE OF IDENTICAL CONSTRUCTION.

SINGLE SPAN CONCRETE EMBEDDED ASSEMBLY
 DOUBLE SPAN DRIVEN ASSEMBLY
 END, CORNER, PULL OR STRETCHER POSTS ASSEMBLY

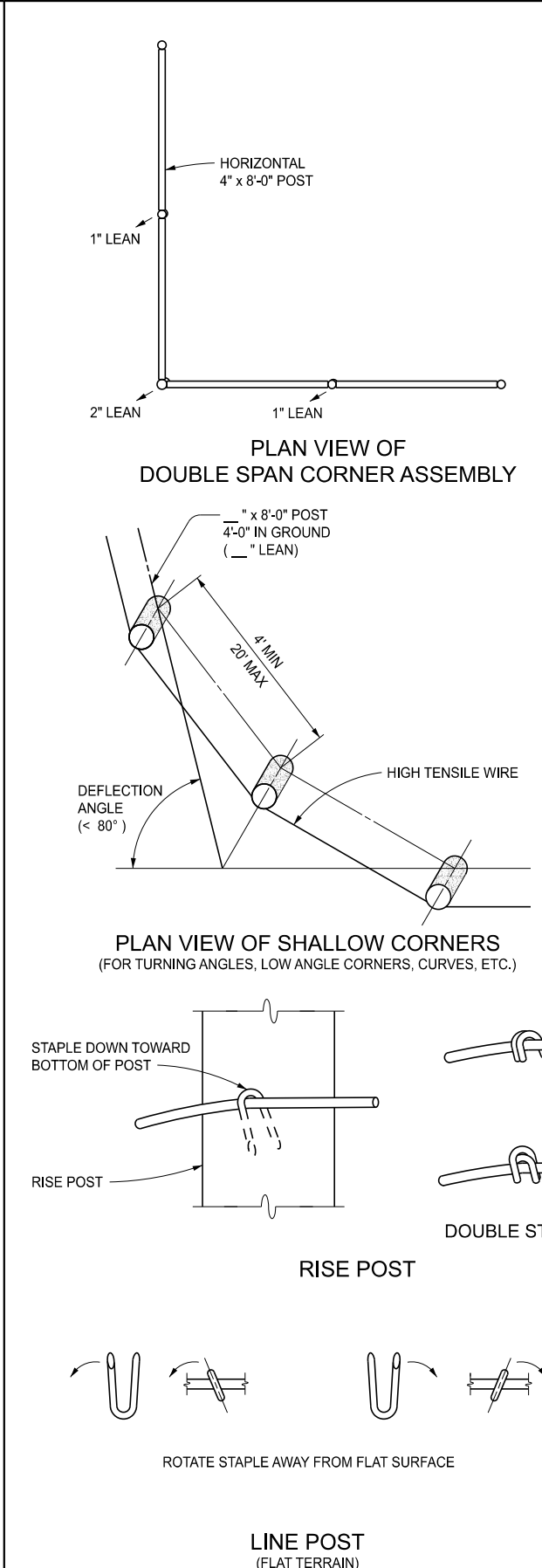

NOTES FOR TURNING CORNERS:
 WHEN TURNING CORNERS OR A NUMBER OF ANGLES AS ON A SMALL RADIUS RAMP CURVE WITH A MAXIMUM DEFLECTION ANGLE OF 80° USE THE FOLLOWING DATA:
 0° - 10° DIRECTIONAL CHANGE, 4" DIAMETER x 8'-0" POST ON 4" LEAN.
 11° - 20° DIRECTIONAL CHANGE, 5" DIAMETER x 8'-0" POST ON 5" LEAN.
 21° - 30° DIRECTIONAL CHANGE, 6" DIAMETER x 8'-0" POST ON 5" LEAN.
 ENSURE SINGLE ANGLES ARE NO GREATER THAN 30°. MACHINE DRIVE POSTS. LEAN POSTS OUT OF THE TURN OR CURVE. LOCATE POSTS ON THE INSIDE OF THE WIRE ON A CURVE (RADIUS SIDE).
 IT IS PREFERABLE TO HAVE APPROXIMATELY 80' BETWEEN MAJOR TURNS OR DIRECTIONAL CHANGES.

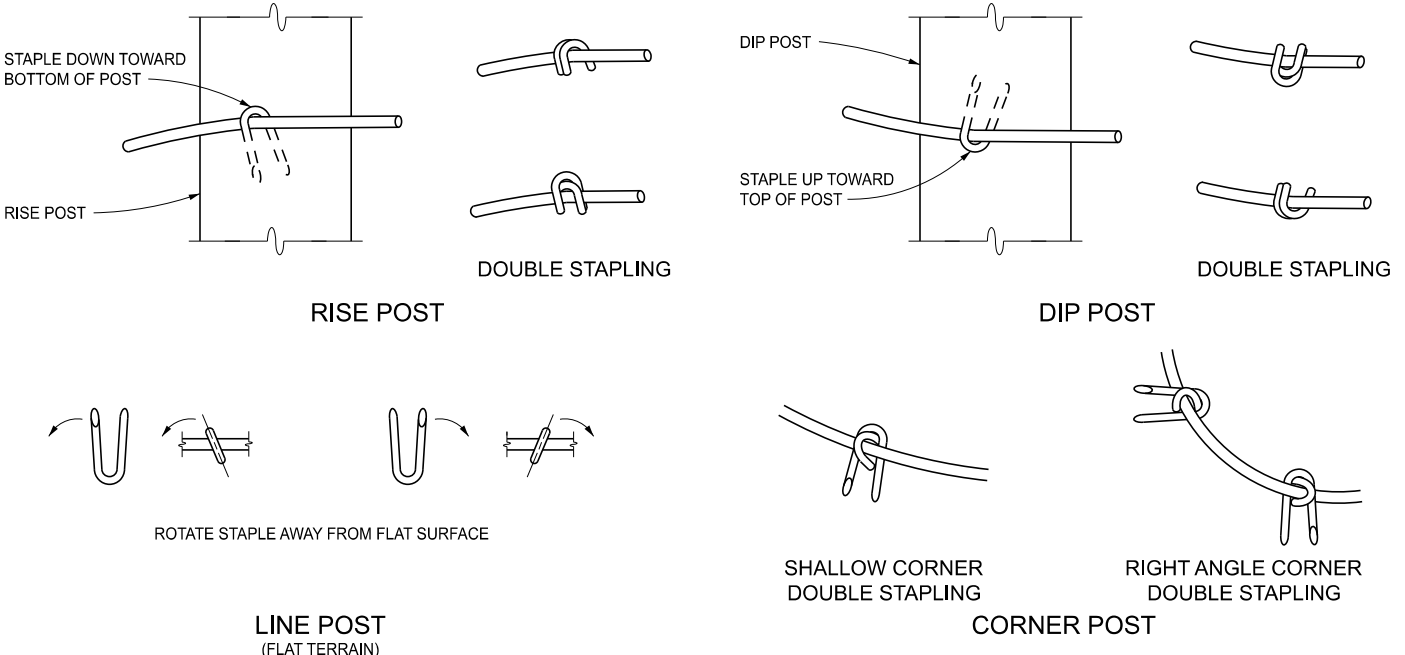
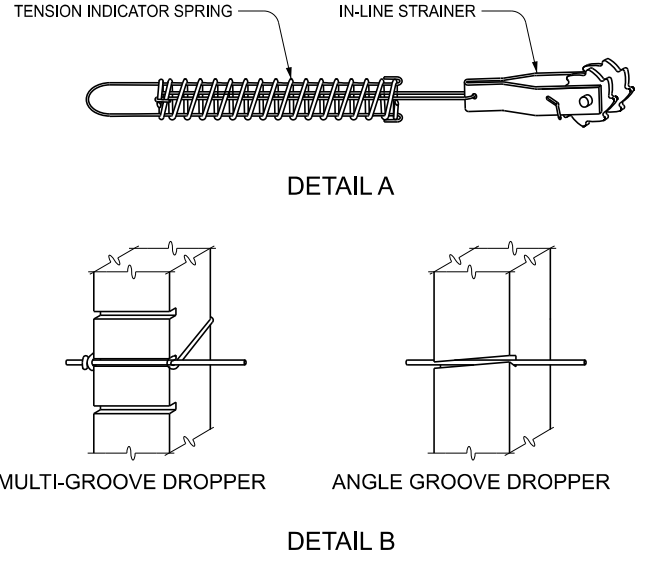

APPROVED BY: _____
 DIRECTOR, BUREAU OF FIELD SERVICES

APPROVED BY: _____
 DIRECTOR, BUREAU OF DEVELOPMENT



DEPARTMENT DIRECTOR
 BRADLEY C. WIEFERICH, PE

STANDARD PLAN FOR HIGH TENSILE EIGHT WIRE FENCE			
SPECIAL DETAIL	01/07/2025	R-97-D	SHEET 1 OF 4
FHWA APPROVAL	PLAN DATE		



DEPARTMENT DIRECTOR
 BRADLEY C. WIEFERICH, PE

STANDARD PLAN FOR HIGH TENSILE EIGHT WIRE FENCE			
SPECIAL DETAIL	01/07/2025	R-97-D	SHEET 2 OF 4
FHWA APPROVAL	PLAN DATE		

SECT

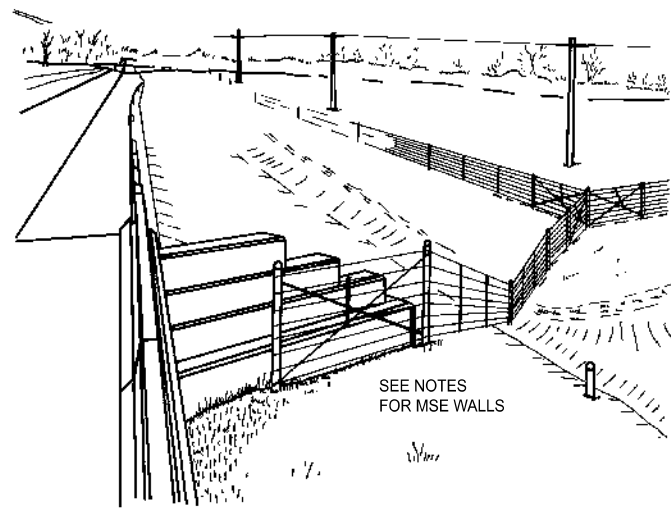

BRIDGES WITH SLOPE-WALLS

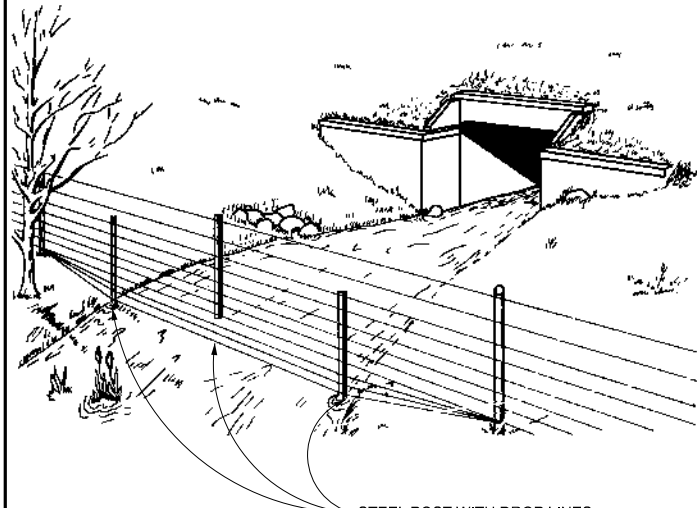

DRAINAGE DITCH OR SMALL STREAM

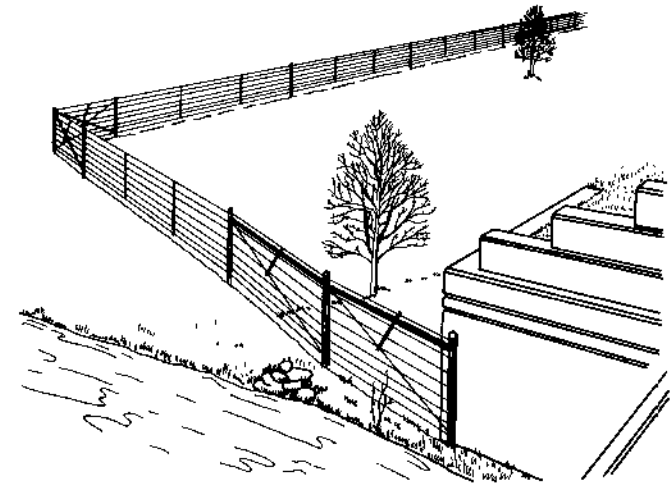

STREAM CROSSING

NOTE: FOR THIS DETAIL, USE 6" x 8'-0" POSTS EMBEDDED IN CONCRETE ON ALL POSTS THAT ARE PART ON THE DEFLECTION ANGLE WHICH TAKES THE FENCE OUT OF ITS NORMAL PARALLELING DIRECTION ALONG THE ROADWAY.

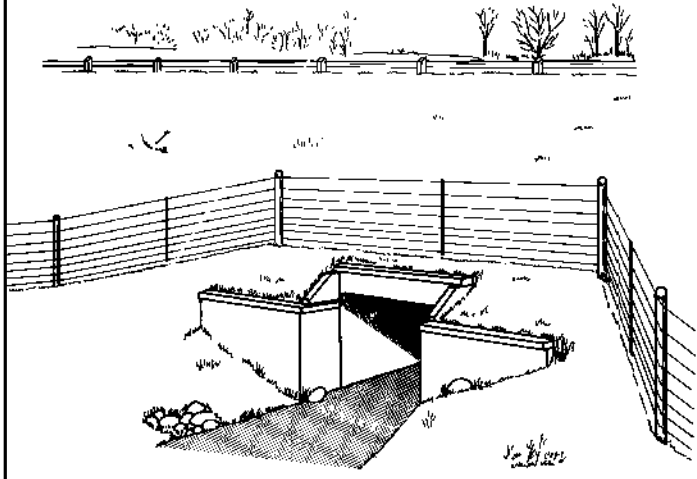

CATTLE CROSSING

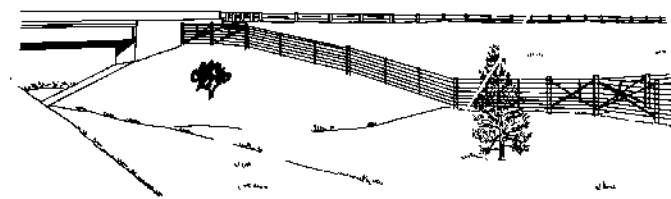

BRIDGES WITH TURN BACK WINGWALLS

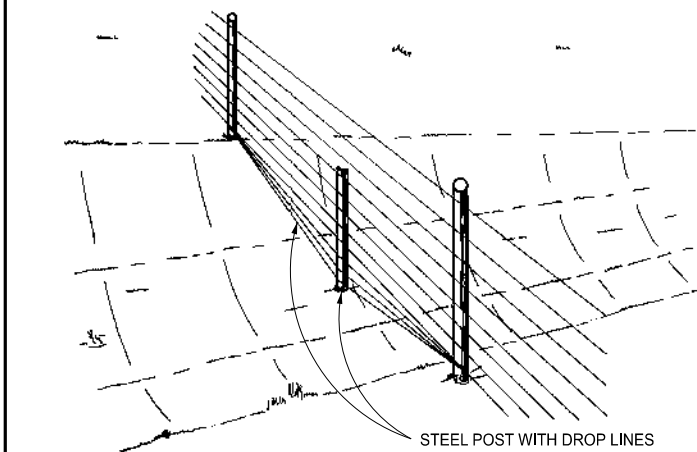

NOTE: USE THIS DETAIL WITH RAVINES WHICH REQUIRE A SPAN OF 40' OR LESS. FOR RAVINES REQUIRING A SPAN THAT IS GREATER THAN 40', PLACE A 4" DIAMETER x 8'-0" DIP POST IN PLACE OF STEEL POST, RUN WIRES LIKE LEVEL FENCE.

SHALLOW RAVINE

NOTES:

EXCEPT FOR POSTS EMBEDDED IN CONCRETE, MECHANICALLY DRIVE ALL POSTS INTO THE GROUND WHERE SOIL CONDITIONS PERMIT. DRIVE THE SMALL END OF THE POSTS INTO THE GROUND. WHERE THE ENGINEER DETERMINES POOR SOIL CONDITIONS EXIST, EMBED POSTS IN CONCRETE.

POST SIZES INDICATED ON THESE PLANS ARE MINIMUM DIAMETERS MEASURED ON THE SMALL END.

THE MAXIMUM POST SPACING IS 40' ON LEVEL TERRAIN WITH DROPPERS ON 10' CENTERS. POST SPACING MAY BE DECREASED DUE TO UNEVEN TERRAIN WITH A MAXIMUM SPACING OF 15' BETWEEN DROPPERS. POST SPACINGS OF 15' OR LESS DO NOT REQUIRE DROPPERS.

PLACE IN-LINE STRAINERS AS CLOSE AS POSSIBLE TO THE CENTER OF THE FENCE RUN. PLACE TENSION INDICATOR SPRING ON THE SECOND WIRE FROM THE TOP. ONE SPRING REQUIRED PER FENCE RUN.

MAXIMUM TOTAL LENGTH OF WIRE PER IN-LINE STRAINER (OR FENCE RUN) ON LEVEL TERRAIN, STRAIGHT = 5000', 1-90° CORNER = 3000', 2-90° CORNERS = 2000', 3-90° CORNERS = 1500', 4-90° CORNERS = 1000'. THE 90° CORNERS MAY BE A TOTAL OF DEFLECTION ANGLES EQUALING THE CORNER OR CORNERS. FOR UNEVEN TERRAIN, REDUCE DISTANCES BY 500' FOR EACH MAJOR DIP OR RISE.

STAPLE WIRES AS SPECIFIED ON THIS PLAN USING 1-3/4" x 9 GAGE ZINC COATED STAPLES. DRIVE STAPLES TO ALLOW JUST ENOUGH ROOM BETWEEN THE STAPLES AND WIRE SO THE WIRE CAN MOVE FREELY WHEN FENCE EXPANDS AND CONTRACTS.

USE 5/8" x 8'-0" LONG GALVANIZED STEEL RODS FOR GROUND RODS. PLACE GROUND RODS EVERY 300'. USE ONE GROUND ROD DIRECTLY UNDER POWER LINES AND ONE ON EACH SIDE 25' TO 50' AWAY. THE EXACT LOCATION SHALL BE DETERMINED BY THE ENGINEER. USE WIRE CLAMP OR OTHER APPROVED DEVICE TO ATTACH GROUND WIRES TO GROUND ROD.

IT IS RECOMMENDED TO USE CRIMP TYPE OR PRESS TYPE SLEEVES FOR TYING FENCE WIRES AT END OF STRETCHER POSTS AND FOR WIRE SPLICES. USE TWO SLEEVES ON END WIRES AND THREE SLEEVES FOR SPLICES. OTHER DEVICES MAY BE SUBSTITUTED FOR THE APPROVED SLEEVES.

A 4" DIAMETER WOOD POST MAY BE SUBSTITUTED FOR THE ANGLE CROSS BRACE. STEEL TUBING, PIPE, OR CHANNELS MAY ALSO BE USED FOR SUBSTITUTES IF SHOWN TO BE EQUIVALENT IN STRENGTH AND APPROVED BY THE ENGINEER.

TWIST THE WIRES WITH A TWITCH STICK TO PUT PROPER TENSION ON THE WIRE CROSS BRACE. SECURE THE TWITCH STICK TO THE HORIZONTAL POST OR TO THE CROSS BRACE (PIPE, TUBE, CHANNEL).

PRESSURE TREAT ALL FENCE POSTS, HORIZONTAL POSTS, WOODEN DROPPERS, AND TWITCH STICKS. DROPPERS MAY BE CONSTRUCTED OF FIBERGLASS OR PLASTIC; CLIPS ARE REQUIRED.

GALVANIZE ALL HARDWARE: WIRE, STAPLES, STRAINERS, PINS, ANGLE CROSS BRACES, ETC., ACCORDING TO THE STANDARD SPECIFICATIONS FOR CONSTRUCTION.

FOR MECHANICALLY STABILIZED EARTH (MSE) WALLS, TERMINATE THE FENCE AGAINST THE SIDE OF THE WALL OPPOSITE THE STABILIZED EARTH. DO NOT DRIVE POSTS IN MECHANICALLY STABILIZED EARTH.



DEPARTMENT DIRECTOR
BRADLEY C. WIEFERICH, PE

SPECIAL DETAIL
FHWA APPROVAL

01/07/2025
PLAN DATE

R-97-D

SHEET
3 OF 4



DEPARTMENT DIRECTOR
BRADLEY C. WIEFERICH, PE

SPECIAL DETAIL
FHWA APPROVAL

01/07/2025
PLAN DATE

R-97-D

SHEET
4 OF 4

SECT

STANDARD PLAN FOR
HIGH TENSILE EIGHT WIRE FENCE

STANDARD PLAN FOR
HIGH TENSILE EIGHT WIRE FENCE