

SIDE VIEW
(TRANSVERSE DRAINAGE INSTALLATION SHOWN)
METAL CULVERT SLOPED END SECTION FOR CORRUGATED METAL PIPE

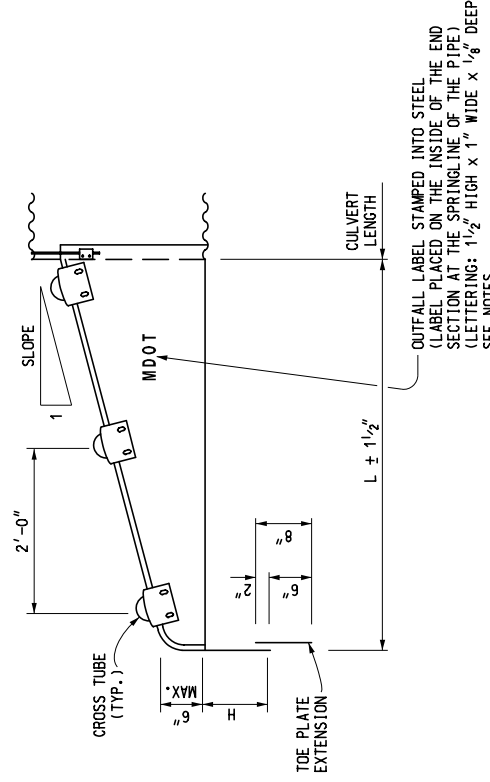

SIDE VIEW
(LONGITUDINAL DRAINAGE INSTALLATION SHOWN)
METAL CULVERT SLOPED END SECTION FOR ARCH PIPE

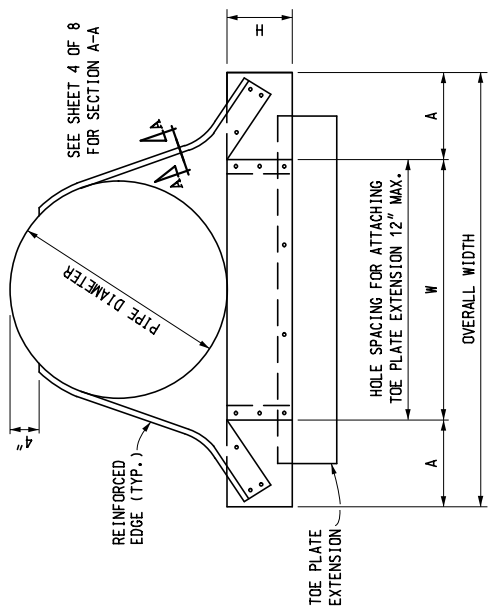

END VIEW

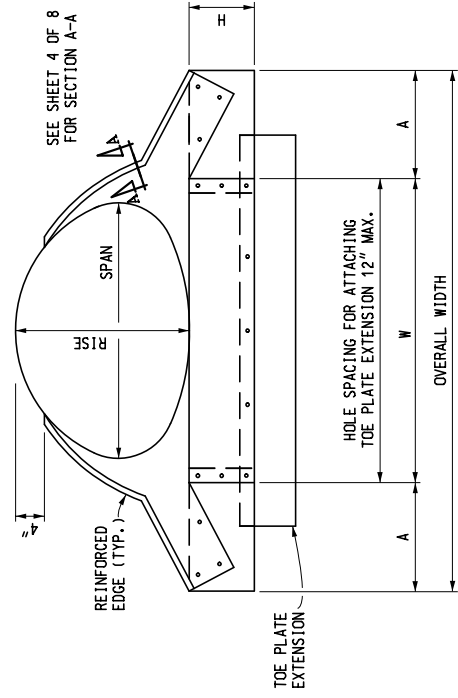

END VIEW



PREPARED BY
DESIGN DIVISION
DRAWN BY: B.L.T.
CHECKED BY: W.K.P.

DEPARTMENT DIRECTOR
Paul C. Ajegba

APPROVED BY: Gregg Brunner, P.E. Gregg Brunner
Jul 24 2019 11:25 AM
DIRECTOR, BUREAU OF FIELD SERVICES

APPROVED BY: Bradley C. Wiefelrich Bradley C. Wiefelrich
Jul 3 2019 9:09 AM
DIRECTOR, BUREAU OF DEVELOPMENT

MICHIGAN DEPARTMENT OF TRANSPORTATION
BUREAU OF DEVELOPMENT STANDARD PLAN FOR

CULVERT SLOPED END SECTIONS
(CONCRETE AND METAL)

5-18-2020
F.H.W.A. APPROVAL

9-19-2018
PLAN DATE

R-95-G

SHEET
1 OF 7

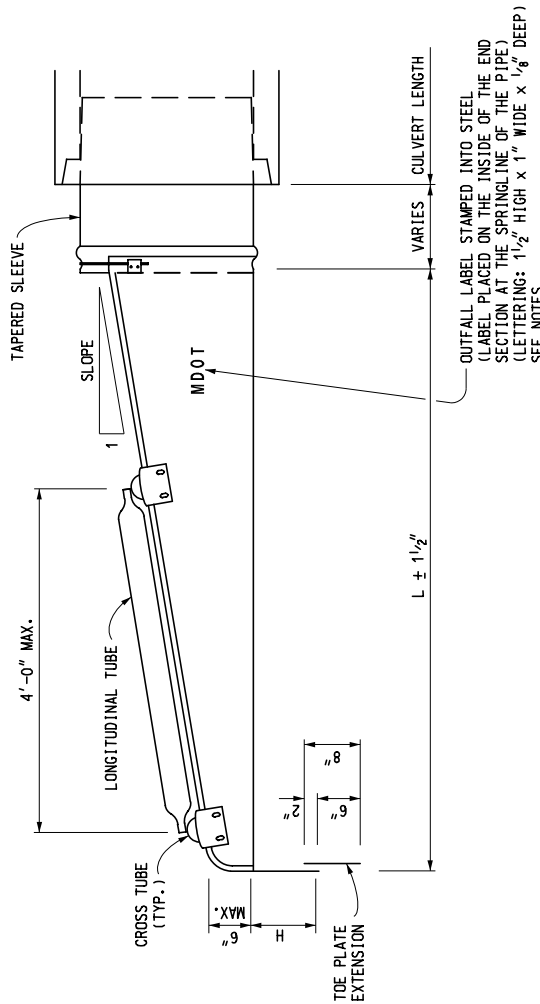

SIDE VIEW
(TRANSVERSE DRAINAGE INSTALLATION SHOWN)

METAL CULVERT SLOPED END SECTION FOR ELLIPTICAL CONCRETE PIPE

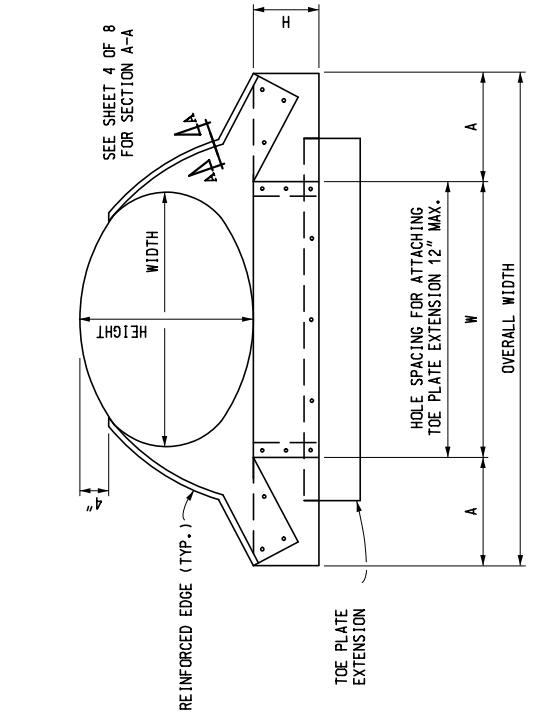

END VIEW

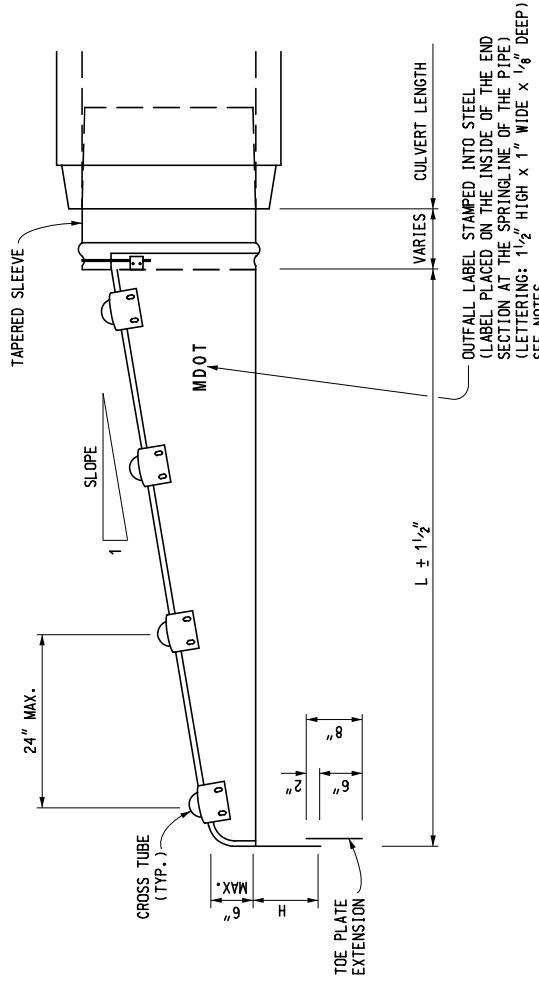

SIDE VIEW
(LONGITUDINAL DRAINAGE INSTALLATION SHOWN)

METAL CULVERT SLOPED END SECTION AND CONNECTION TO CIRCULAR CONCRETE PIPE

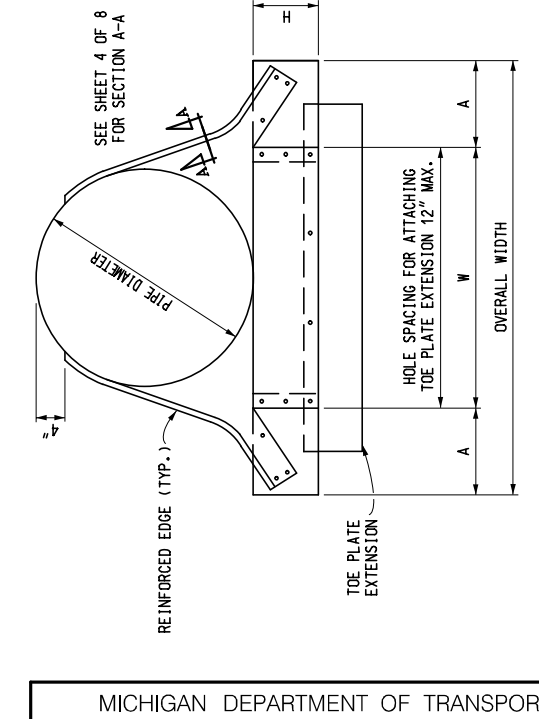

END VIEW

MICHIGAN DEPARTMENT OF TRANSPORTATION BUREAU OF DEVELOPMENT STANDARD PLAN FOR CULVERT SLOPED END SECTIONS (CONCRETE AND METAL)		
5-18-2020 F.H.W.A. APPROVAL	9-19-2018 PLAN DATE	R-95-G
		SHEET 2 OF 7

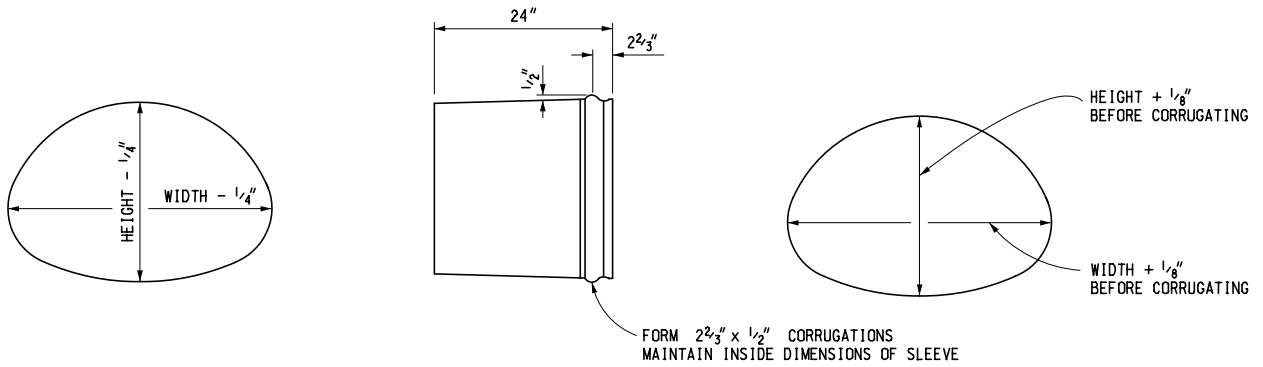

TAPERED SLEEVE FOR ELLIPTICAL PIPE
(METAL END SECTION)

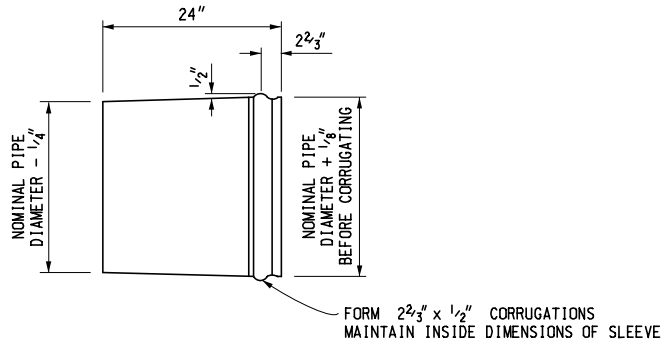

TAPERED SLEEVE FOR CIRCULAR PIPE
(METAL END SECTION)

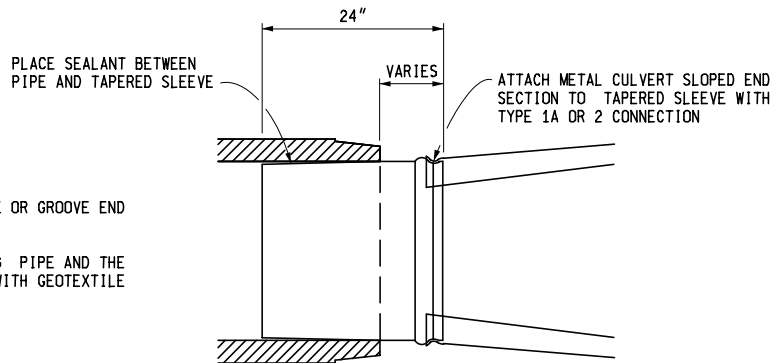

NOTE:

TAPERED SLEEVE SHALL BE MADE TO FIT TONGUE OR GROOVE END OF PIPE.

THE CONNECTION JOINT BETWEEN THE EXISTING PIPE AND THE METAL SLOPED END SECTION MUST BE WRAPPED WITH GEOTEXTILE BLANKET 36" WIDE WITH A 12" OVERLAP.

**TOP VIEW OF TAPERED SLEEVE FOR
CONNECTING METAL CULVERT SLOPED END SECTION
TO CONCRETE PIPE OR CORRUGATED POLYETHYLENE PIPE**

MICHIGAN DEPARTMENT OF TRANSPORTATION
BUREAU OF DEVELOPMENT STANDARD PLAN FOR

**CULVERT
SLOPED END SECTIONS
(CONCRETE AND METAL)**

5-18-2020
F.H.W.A. APPROVAL

9-19-2018
PLAN DATE

R-95-G

SHEET
3 OF 7

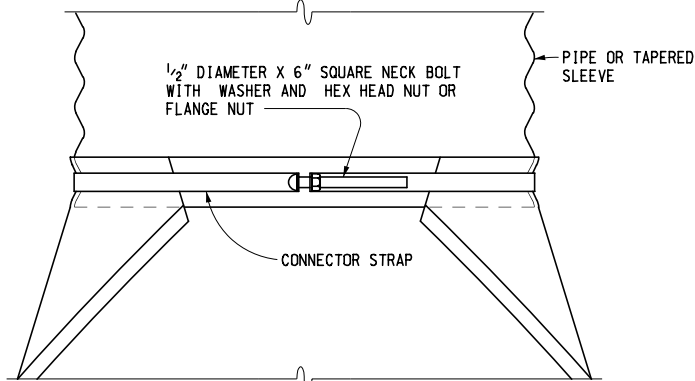
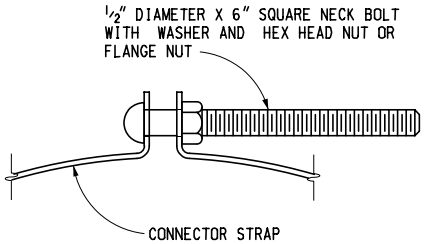
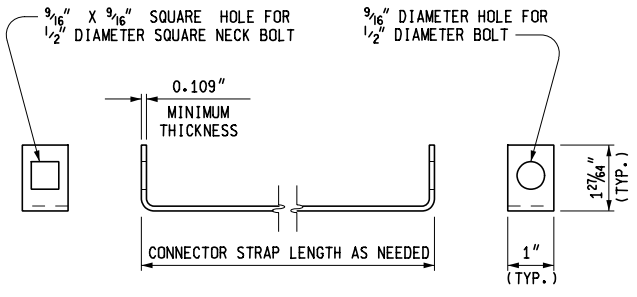

TYPE 1A CONNECTOR
FOR USE ON CIRCULAR PIPE DIAMETERS 15" THROUGH 24"

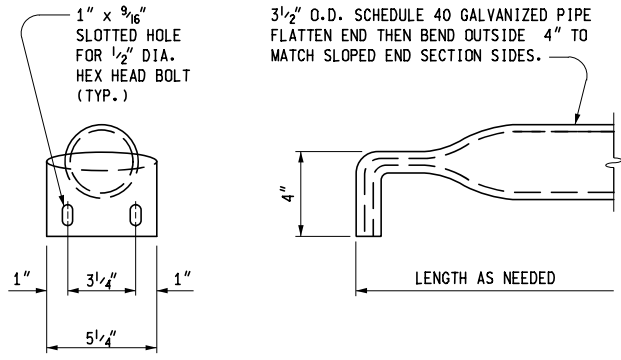

CROSS TUBE

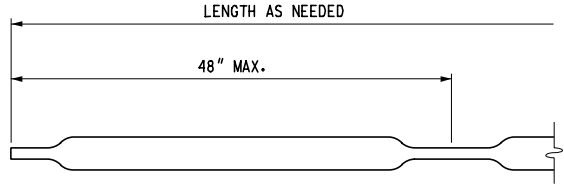

LONGITUDINAL TUBE

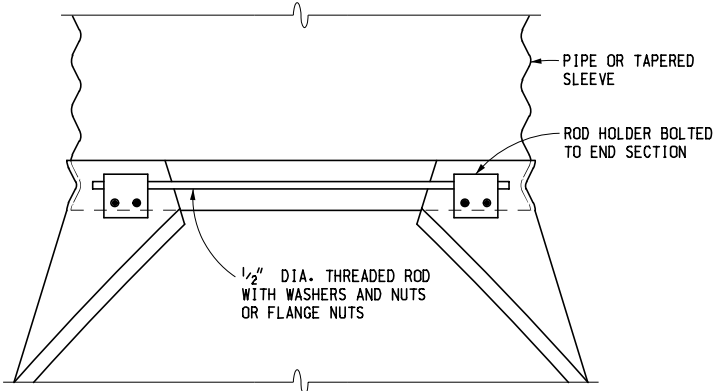

TYPE 2 CONNECTOR
FOR USE ON CIRCULAR PIPE DIAMETERS 27" THROUGH 60" AND FOR ALL ARCH AND ELLIPTICAL PIPE SIZES

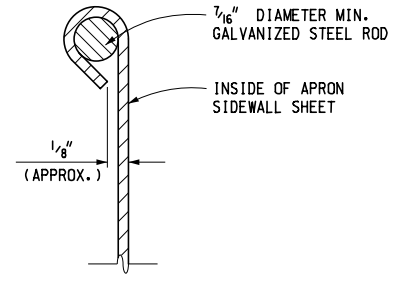

SECTION A - A
FOR PLAN VIEW SEE SHEETS 1 AND 2

MICHIGAN DEPARTMENT OF TRANSPORTATION
BUREAU OF DEVELOPMENT STANDARD PLAN FOR

**CULVERT
SLOPED END SECTIONS
(CONCRETE AND METAL)**

5-18-2020
F.H.W.A. APPROVAL

9-19-2018
PLAN DATE

R-95-G

SHEET
4 OF 7

NOTE:
 IN LONGITUDINAL DRAINAGE SITUATIONS, CROSS TUBES ARE REQUIRED AT A 24" MAXIMUM SPACING. THE NUMBER OF CROSS TUBES REQUIRED WILL VARY DEPENDING ON THE LENGTH OF THE CULVERT SLOPED END SECTION.

OUTFALL LABEL STAMPED INTO STEEL
 (LABEL PLACED ON THE INSIDE OF THE END SECTION AT THE SPRINGLINE OF THE PIPE)
 (LETTERING: 1 1/2" HIGH x 1" WIDE x 1/8" DEEP)
 SEE NOTES

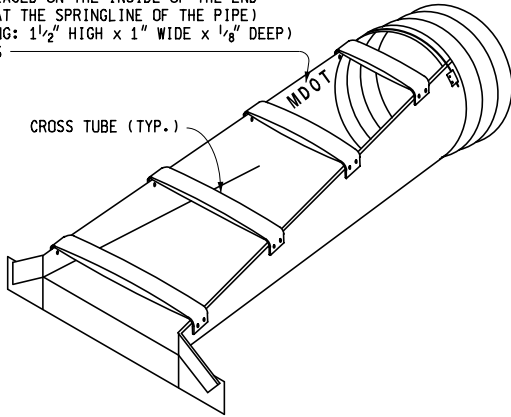

METAL CULVERT SLOPED END SECTION
 SHOWING CROSS TUBES USED FOR
 LONGITUDINAL DRAINAGE INSTALLATIONS

OUTFALL LABEL STAMPED INTO STEEL
 (LABEL PLACED ON THE INSIDE OF THE END SECTION AT THE SPRINGLINE OF THE PIPE)
 (LETTERING: 1 1/2" HIGH x 1" WIDE x 1/8" DEEP)
 SEE NOTES

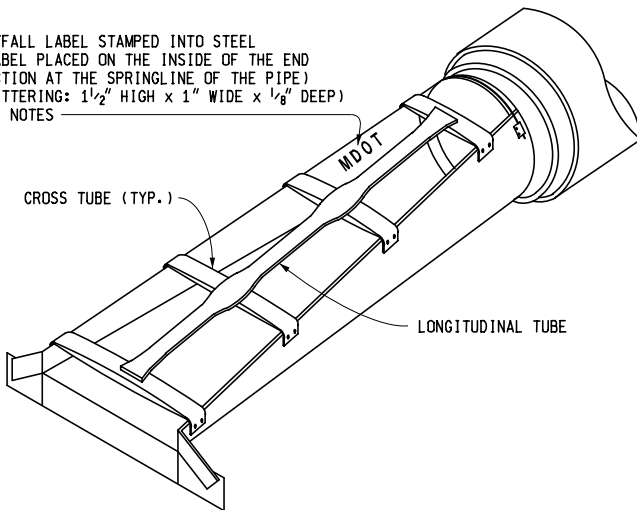

NOTE:
 IN TRANSVERSE DRAINAGE SITUATIONS, NO TUBES ARE REQUIRED WHEN THE "W" DIMENSION IS 30" OR LESS. CROSS TUBES ARE REQUIRED WHEN THE CLEAR SPAN DIMENSION IS LARGER THAN 30". THE NUMBER OF CROSS TUBES WILL VARY DEPENDING ON THE LENGTH OF THE LONGITUDINAL TUBE REQUIRED. WHEN THE "W" DIMENSION IS 36" TO 60", ONE LONGITUDINAL TUBE IS REQUIRED. WHEN THE "W" DIMENSION IS LARGER THAN 60", TWO LONGITUDINAL TUBES EQUALLY SPACED ARE REQUIRED. LONGITUDINAL TUBES SHALL BE WELDED TO CROSS TUBES TO ATTAIN A SINGLE PIECE STRUCTURE.

METAL CULVERT SLOPED END SECTION
 SHOWING CROSS TUBES AND LONGITUDINAL TUBE
 USED FOR TRANSVERSE DRAINAGE INSTALLATIONS
 (CONNECTED TO CONCRETE PIPE SHOWN)

METAL SLOPED END SECTIONS FOR
 ARCH PIPES

SPAN/ RISE (INCHES)	MINIMUM THICKNESS (INCHES)	DIMENSIONS (INCHES)				L DIMENSIONS (INCHES)	
		A	H	W	OVERALL WIDTH	LENGTH (SLOPE 4:1)	LENGTH (SLOPE 6:1)
21 X 15	.064	8	6	27	43	20	30
24 X 18	.064	8	6	30	46	32	48
28 X 20	.064	8	6	34	50	40	60
35 X 24	.079	12	9	41	65	56	84
42 X 29	.109	12	9	48	72	76	114
49 X 33	.109	16	12	55	87	92	138
57 X 38	.109	16	12	63	95	112	168
64 X 43	.109	16	12	70	102	132	198
71 X 47	.109	16	12	77	109	148	222
77 X 52	.109	16	12	83	115	168	252
83 X 57	.109	16	12	89	121	188	282

METAL SLOPED END SECTIONS FOR
 CIRCULAR PIPES
 (STEEL OPTION)

PIPE DIA. (INCHES)	MINIMUM THICKNESS (INCHES)	DIMENSIONS (INCHES)				L DIMENSIONS (INCHES)	
		A	H	W	OVERALL WIDTH	LENGTH (SLOPE 4:1)	LENGTH (SLOPE 6:1)
15	.064	8	6	21	37	20	30
18	.064	8	6	24	40	32	48
21	.064	8	6	27	43	44	66
24	.064	8	6	30	46	56	84
27	.109	12	9	33	57	68	102
30	.109	12	9	36	60	80	120
36	.109	12	9	42	66	104	156
42	.109	16	12	48	80	128	192
48	.109	16	12	54	86	152	228
54	.109	16	12	60	92	176	264
60	.109	16	12	66	98	200	300

METAL SLOPED END SECTIONS FOR
 ELLIPTICAL PIPES

HEIGHT/ WIDTH (INCHES)	MINIMUM THICKNESS (INCHES)	DIMENSIONS (INCHES)				L DIMENSIONS (INCHES)	
		A	H	W	OVERALL WIDTH	LENGTH (SLOPE 4:1)	LENGTH (SLOPE 6:1)
14 X 23	.064	8	6	29	45	16	24
19 X 30	.064	8	6	36	52	36	54
22 X 34	.079	12	9	40	64	48	72
24 X 38	.079	12	9	44	68	56	84
27 X 42	.109	12	9	48	72	68	102
29 X 45	.109	16	12	51	83	76	114
34 X 53	.109	16	12	59	91	96	144
38 X 60	.109	16	12	66	98	112	168
43 X 68	.109	16	12	74	106	132	198
48 X 76	.109	16	12	80	112	152	228

MICHIGAN DEPARTMENT OF TRANSPORTATION
 BUREAU OF DEVELOPMENT STANDARD PLAN FOR

CULVERT
 SLOPED END SECTIONS
 (CONCRETE AND METAL)

5-18-2020
 F.H.W.A. APPROVAL

9-19-2018
 PLAN DATE

R-95-G

SHEET
 5 OF 7

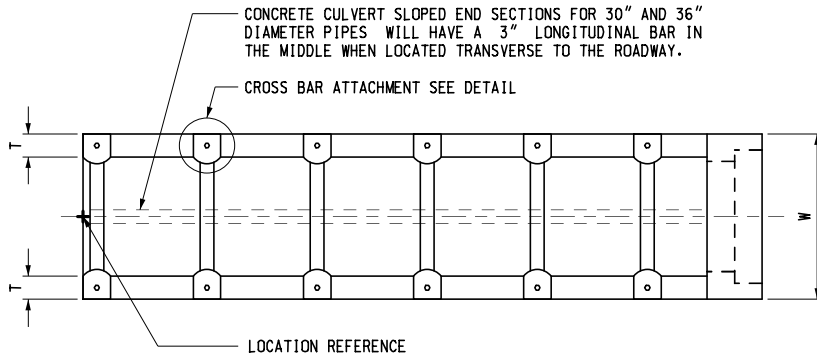

PLAN VIEW

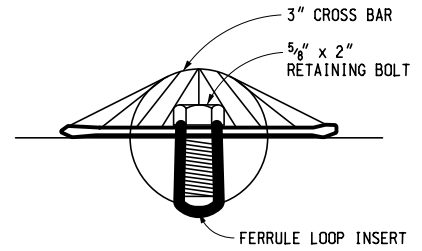

CROSS BAR ATTACHMENT DETAIL

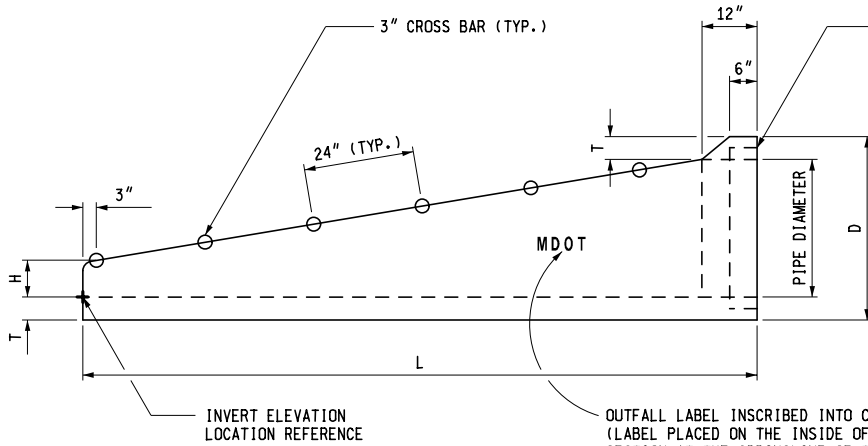

SIDE VIEW

GROOVED END ON OUTLET END SECTION
TONGUE END ON INLET END SECTION
GROOVE OR TONGUE TO BE THE SAME AS
ON STANDARD REINFORCED CONCRETE
PIPE A.S.T.M. DESIGNATION C 76M.

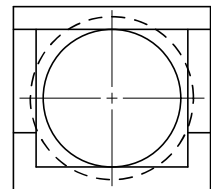

END VIEW

CONCRETE CULVERT SLOPED END FOR CIRCULAR PIPE

CONCRETE SLOPED END SECTIONS FOR CIRCULAR PIPES						
PIPE DIA. (INCHES)	SLOPE	DIMENSIONS (INCHES)				
		D	L	W	T	H
15	6:1	25	57	25	5	8
18	4:1	28	55	28	5	8
	6:1	28	75	28	5	8
24	4:1	34	79	36	5	8
	6:1	34	111	36	5	8
30	4:1	40	104	43	5	8
	6:1	40	147	43	5	8
36	4:1	47	127	51	5 1/2	8
	6:1	47	183	51	5 1/2	8

MICHIGAN DEPARTMENT OF TRANSPORTATION
BUREAU OF DEVELOPMENT STANDARD PLAN FOR

CULVERT
SLOPED END SECTIONS
(CONCRETE AND METAL)

5-18-2020
F.H.W.A. APPROVAL

9-19-2018
PLAN DATE

R-95-G

SHEET
6 OF 7

NOTE: ALL STEEL REINFORCEMENT SHALL BE #4 BARS

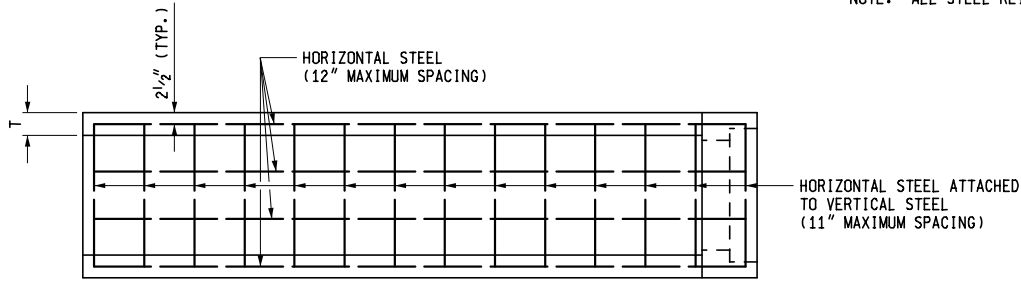

PLAN VIEW

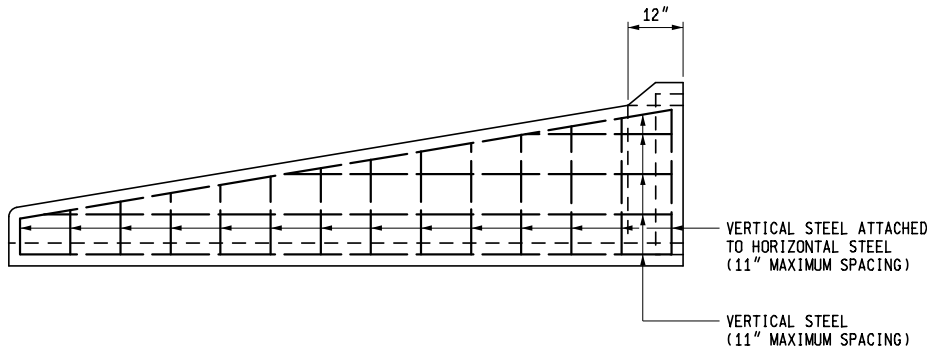

SIDE VIEW

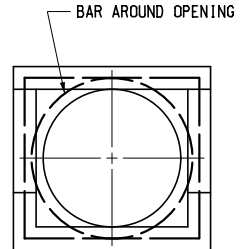

END VIEW

STEEL REINFORCEMENT FOR CONCRETE CULVERT SLOPED END

NOTES:

GALVANIZED STEEL SHALL MEET THE REQUIREMENTS IN THE CURRENT STANDARD SPECIFICATIONS FOR CONSTRUCTION.

GALVANIZED TOE PLATE EXTENSIONS ARE REQUIRED ON METAL CULVERT SLOPED END SECTIONS WHEN INDICATED ON THE PLANS OR BY AUTHORIZATION WHEN EITHER HEIGHT OF FILL IS 10'-0" OR MORE OR WHEN THE CULVERT GRADE IS 10% OR MORE. THEY SHALL BE MATCHED-PUNCHED TO FIT HOLES IN TOE PLATE AND SUPPLIED LOOSE, COMPLETE WITH 3/8" DIAMETER GALVANIZED BOLTS. TOE PLATE EXTENSIONS SHALL BE THE SAME THICKNESS AS THE METAL CULVERT SLOPED END SECTION. LENGTH OF TOE PLATE EXTENSION IS "OVERALL WIDTH" LESS 6".

CORRUGATED METAL PIPES, ARCHED PIPES, AND SMOOTH TAPERED SLEEVES THAT ARE SHOWN ON THIS PLAN HAVE 2 2/3" x 1/2" CORRUGATIONS. EQUIVALENT PIPE AND SLEEVE SIZES WITH 3" x 1" OR 5" x 1" CORRUGATIONS WILL BE ALLOWED.

FOR BOTH METAL AND CONCRETE CULVERT SLOPED END SECTIONS, CROSS AND LONGITUDINAL BARS/TUBES SHALL BE SCHEDULE 40 GALVANIZED PIPE, A.S.T.M. A53. WHEN PARALLEL BARS/TUBES ARE WELDED TO CROSS TUBES, DAMAGED GALVANIZED SURFACES SHALL BE REPAIRED ACCORDING TO SECTION 716 OF THE STANDARD SPECIFICATIONS.

SLOTTED HOLES FOR PARALLEL TUBE ATTACHMENT SHALL BE PROVIDED FOR ALL METAL CULVERT SLOPED END SECTIONS.

SMOOTH TAPERED SLEEVES (FOR METAL END SECTIONS) SHALL BE GALVANIZED AND HAVE A MINIMUM THICKNESS AS FOLLOWS:

- 0.079" FOR NOMINAL PIPE DIAMETERS LESS THAN 27"
- 0.109" FOR NOMINAL PIPE DIAMETERS 27" AND LARGER
- 0.079" FOR ELLIPTICAL PIPES LESS THAN 24" x 38"
- 0.109" FOR ELLIPTICAL PIPES 24" x 38" AND LARGER

ANY SEAMS IN SMOOTH TAPERED SLEEVES SHALL BE BUTT WELDED.

A TYPE 2 CONNECTOR (FOR METAL END SECTIONS) DESIGNATED FOR ROUND PIPES 27" AND LARGER MAY BE USED ON SMALLER PIPE SIZES.

OUTFALL LABEL TO BE USED ONLY WHERE STORMWATER WILL DISCHARGE DIRECTLY TO THE WATERS OF THE STATE.

MICHIGAN DEPARTMENT OF TRANSPORTATION
BUREAU OF DEVELOPMENT STANDARD PLAN FOR

**CULVERT
SLOPED END SECTIONS
(CONCRETE AND METAL)**

5-18-2020 F.H.W.A. APPROVAL	9-19-2018 PLAN DATE	R-95-G	SHEET 7 OF 7
--------------------------------	------------------------	--------	-----------------