

BRIDGE BARRIER RAILING, TYPE 5
OUTSIDE ELEVATION

SECTION A-A

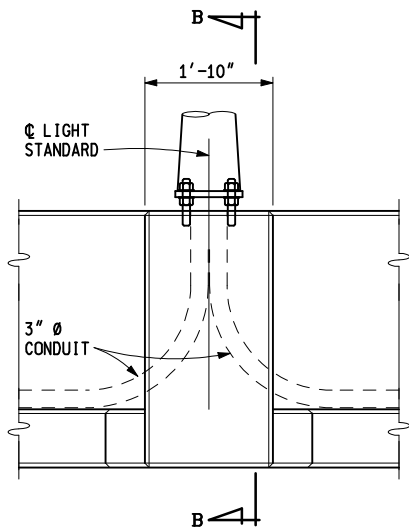

ELEVATION VIEW

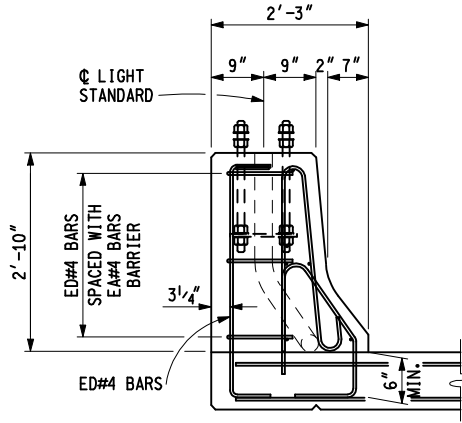

SECTION B-B
LIGHT STANDARD DETAILS

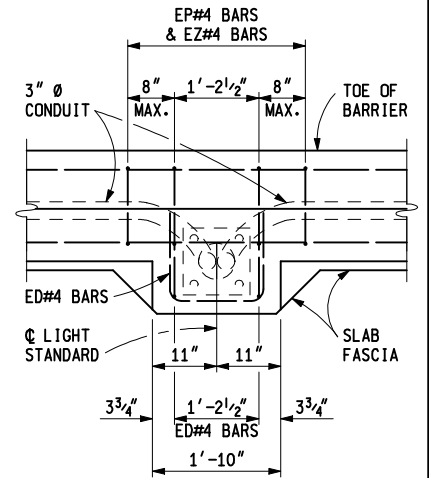

PLAN VIEW

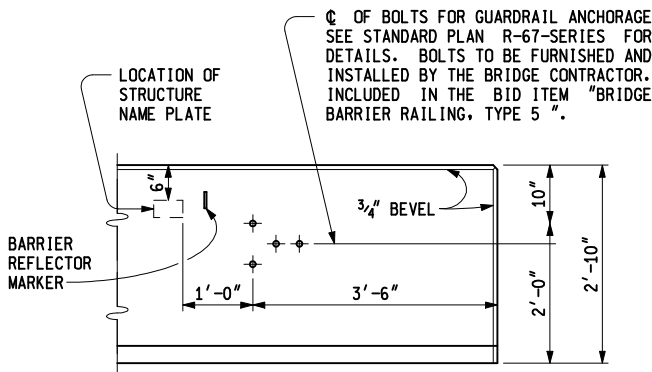

LOCATION OF NAME PLATE
AND GUARDRAIL ANCHORAGE

NOTES:

- DETAILS SHOWN ARE IN ACCORDANCE WITH CURRENT AASHTO SPECIFICATIONS.
- FOR LIGHT STANDARD ANCHOR BOLT ASSEMBLY DETAILS, SEE STANDARD PLAN B-103-SERIES. THE LIGHT STANDARD ANCHOR BOLT ASSEMBLY IS INCLUDED IN THE BID ITEM "BRIDGE BARRIER RAILING, TYPE 5".
- ALL WORK AND MATERIAL SHALL BE IN ACCORDANCE WITH THE STANDARD SPECIFICATIONS.
- * BRIDGE BARRIER ORIENTATION :
PERPENDICULAR TO PLANE OF SLAB ON NORMAL CROWN SECTION AND HIGH SIDE OF SUPERELEVATION SECTION.
VERTICAL ON LOW SIDE OF SUPERELEVATED SECTION.

MDOT
Michigan Department of Transportation

PREPARED BY
DESIGN DIVISION

DRAWN BY: B.L.T.

CHECKED BY: V.Z.

DEPARTMENT DIRECTOR
Kirk T. Steudle

APPROVED BY: [Signature]
ENGINEER OF DELIVERY

APPROVED BY: [Signature]
ENGINEER OF DEVELOPMENT

MICHIGAN DEPARTMENT OF TRANSPORTATION
BUREAU OF HIGHWAY DEVELOPMENT STANDARD PLAN FOR

**BRIDGE BARRIER RAILING,
TYPE 5**

10-21-2008 F.H.W.A. APPROVAL	6-16-2008 PLAN DATE	B-20-D	SHEET 1 OF 1
---------------------------------	------------------------	--------	-----------------