

TYPICAL ELEVATIONS

5 TUBE RAILING SHOWN - 2 TUBE IS SIMILAR

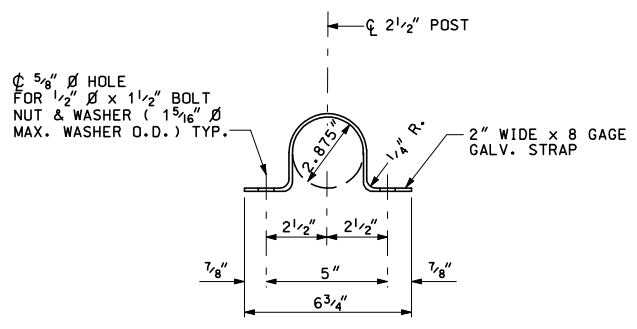

	 ENGINEER OF CONSTRUCTION & TECHNOLOGY	 ENGINEER - STRUCTURES SECTION	MICHIGAN DEPARTMENT OF TRANSPORTATION BUREAU OF HIGHWAY DEVELOPMENT STANDARD PLAN FOR FENCING FOR PEDESTRIAN STRUCTURE 2 OR 5 TUBE STEEL RAILING					
	 ENGINEER OF MAINTENANCE	 DEPARTMENT DIRECTOR Gloria J. Jeff			9-29-2003 F.H.W.A. APPROVAL	12-11-2002 PLAN DATE	B-37-C	SHEET 1 OF 2
PREPARED BY DESIGN SUPPORT AREA	 ENGINEER OF TRAFFIC AND SAFETY	 ENGINEER OF DEVELOPMENT						
DRAWN BY: BLT								
CHECKED BY: VZ								

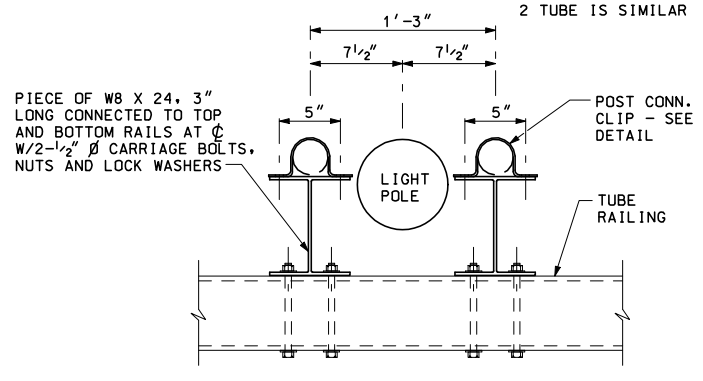
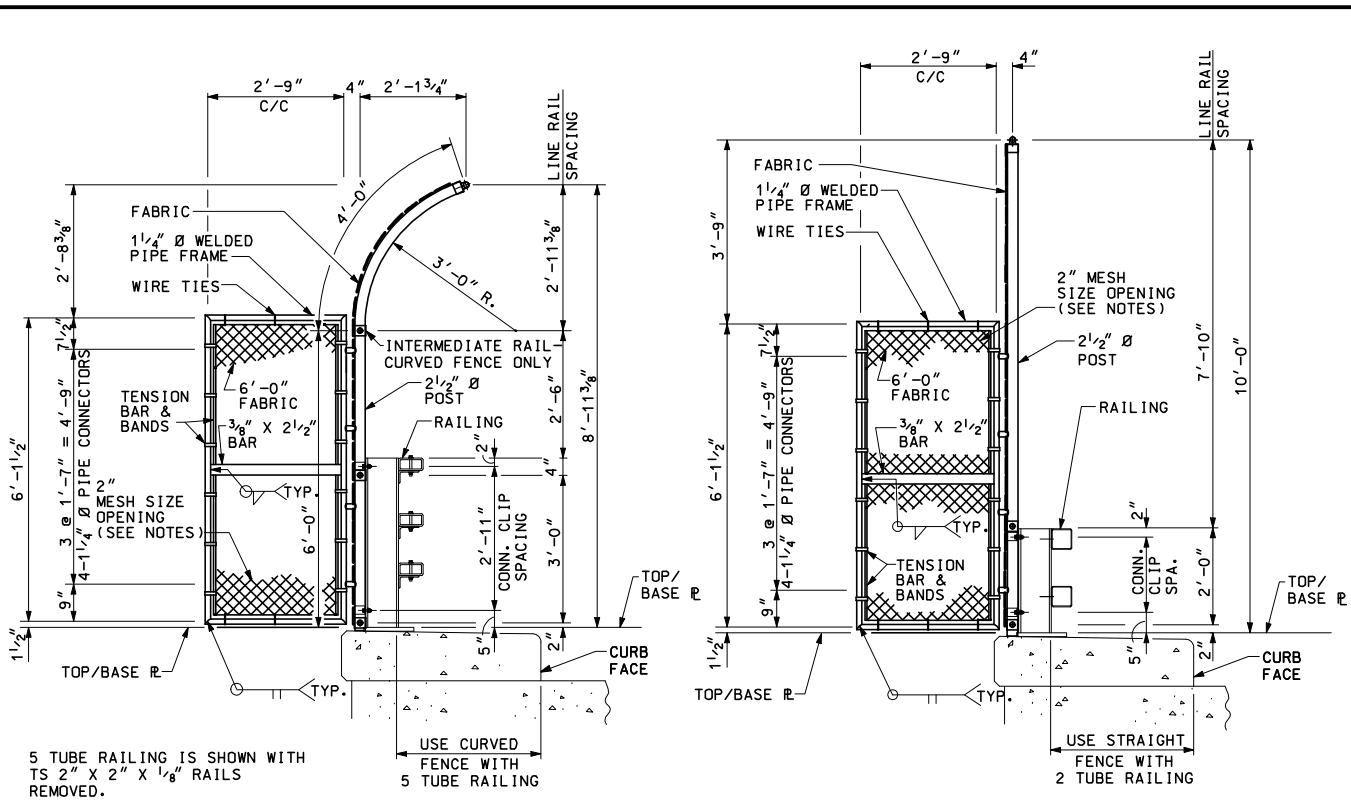

5 TUBE RAILING IS SHOWN WITH TS 2" X 2" X 1/8" RAILS REMOVED.

ANTI-CLIMB SHIELD/POST DETAIL

THE ANTI-CLIMB SHIELD SHALL BE LOCATED AT THE SECOND POST FROM THE END OR AS SHOWN ON THE PLANS OR AS DIRECTED BY THE ENGINEER.

NOTES:

- ALL FENCE POSTS SHALL BE 2 1/2" NOMINAL, (2.875" O.D.) PIPE AND ANTI-CLIMB SHIELD PIPE FRAMES SHALL BE 1 1/4" NOMINAL, (1.66" O.D.) PIPE, IN CONFORMANCE WITH ASTM F669, CLASS 1C.
- HORIZONTAL RAILS SHALL BE 1 1/4" NOMINAL (1.66" O.D.) PIPE IN CONFORMANCE WITH ASTM F669, CLASS 1C OR ASTM F1083.
- ALL FENCE COMPONENTS, UNLESS OTHERWISE INDICATED, SHALL BE GALVANIZED IN ACCORDANCE WITH MDOT'S CURRENT STANDARD SPECIFICATIONS FOR CONSTRUCTION.
- ALL POSTS, ANTI-CLIMB SHIELDS OR OTHER COMPONENTS TO BE FABRICATED SHALL BE FURNISHED "BLACK" AND THEN GALVANIZED AFTER FABRICATION.
- DAMAGED GALVANIZED SURFACES (NEW AND EXISTING) SHALL BE REPAIRED IN CONFORMANCE WITH MDOT'S CURRENT STANDARD SPECIFICATIONS FOR CONSTRUCTION.
- FENCE FABRIC SHALL BE #9 GAGE MESH AND BE GALVANIZED OR ALUMINUM COATED IN CONFORMANCE WITH MDOT'S CURRENT STANDARD SPECIFICATIONS FOR CONSTRUCTION. MESH SIZE OPENING SHALL BE 2" UNLESS 1" MESH SIZE OPENING IS APPROVED BY THE TRAFFIC AND SAFETY DIVISION AND NOTED ON DESIGN PLANS. ALL DETAILS ON STANDARD PLAN SHALL APPLY REGARDLESS OF MESH SIZE OPENINGS.
- GALVANIZED 3/8" Ø TRUSS RODS SHALL EXTEND DIAGONALLY FROM THE TOP CONNECTION CLIP AT EACH TENSION BAR TO THE ADJACENT POST, EXCEPT ACROSS EXPANSION JOINTS AND AT LIGHT STANDARDS WITH A CURVED FENCE DETAIL, WHEN THERE ARE TWO OR MORE CONTINUOUS PANELS OF FABRIC.
- ALL POSTS SHALL BE INSTALLED PLUMB AND MAY BE SHIMMED WITH NON-METALLIC SHIMS, APPROVED BY THE ENGINEER. COSTS FOR SHIMMING SHALL BE INCLUDED IN THE PAY ITEM "FENCE, STRUCTURE".
- THE GROUND WIRE SHALL BE PLACED IN A NON-METALLIC CONDUIT, FROM THE END POST CONNECTION TO THE GROUND ROD CONNECTION. THE CONDUIT SHALL BE SECURED TO THE STRUCTURE USING EITHER EXPANSION BOLTS OR ADHESIVE ANCHORED BOLTS WITH GALVANIZED METAL STRIPS, AS APPROVED BY THE ENGINEER.
- IN THE EVENT THAT INSTALLATION OF A GROUND ROD IS IMPRACTICAL, THE GROUND WIRE SHALL BE CONNECTED TO THE NEAREST LIGHT STANDARD, USING A MECHANICAL CLIP, ONLY AFTER OBTAINING PERMISSION FROM THE LOCAL PUBLIC LIGHTING AUTHORITY.
- EXPANSION JOINT SLEEVES, FOR HORIZONTAL RAILS, SHALL BE THE MANUFACTURER'S STANDARD OVERSIZED SLEEVES, CRIMPED IN THE MIDDLE.
- THE TS 2" X 2" X 1/8" RAILS WILL NOT BE REQUIRED ON BRIDGE RAILING, 2 TUBE OR 5 TUBE USED IN COMBINATION WITH PEDESTRIAN FENCING.
- ALL LABOR, MATERIAL AND EQUIPMENT REQUIRED TO INSTALL PEDESTRIAN FENCING SHALL BE INCLUDED IN PAY ITEM "FENCE, STRUCTURE".

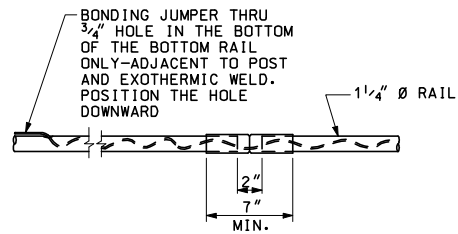

EXPANSION SLEEVE DETAIL

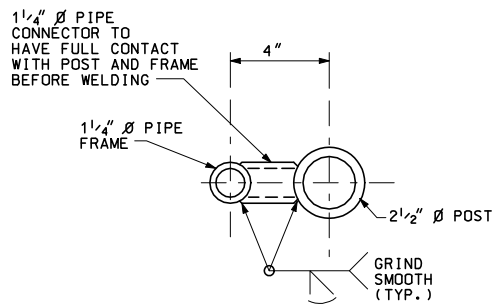

PIPE CONNECTOR DETAIL

USE AT ANTI-CLIMB SHIELD ONLY

MICHIGAN DEPARTMENT OF TRANSPORTATION
 BUREAU OF HIGHWAY DEVELOPMENT STANDARD PLAN FOR
FENCING FOR PEDESTRIAN STRUCTURE
 2 OR 5 TUBE STEEL RAILING

9-29-2003 F.H.W.A. APPROVAL	12-11-2002 PLAN DATE	B-37-C	SHEET 2 OF 2
--------------------------------	-------------------------	--------	-----------------