

TYPICAL ELEVATIONS

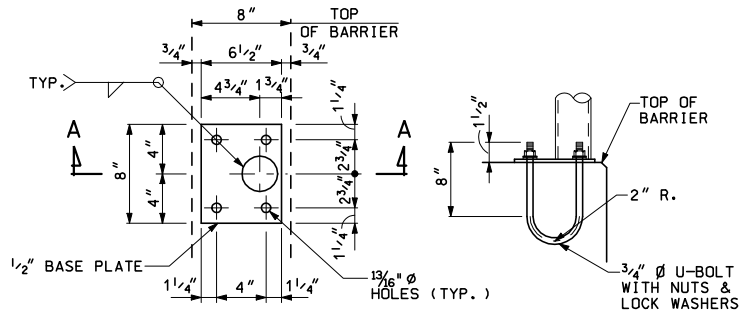

BASE PLATE DETAILS

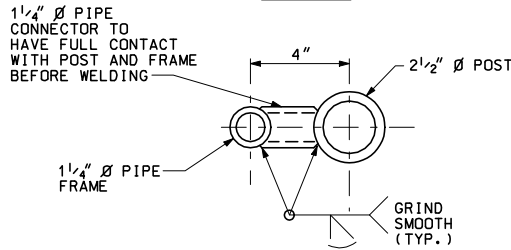
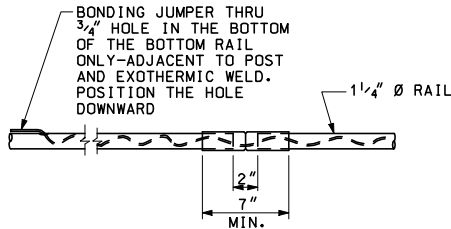

David M. Roberts
ENGINEER OF CONSTRUCTION & TECHNOLOGY

Thomas J. Frank
ENGINEER - STRUCTURES SECTION

MICHIGAN DEPARTMENT OF TRANSPORTATION
BUREAU OF HIGHWAY DEVELOPMENT STANDARD PLAN FOR

FENCING FOR
PEDESTRIAN STRUCTURE
NEW TYPE 4 & 5 BARRIER

PREPARED BY
DESIGN
SUPPORT AREA

Carvin Roberts
ENGINEER OF MAINTENANCE

Max A. Van der Pijl
ENGINEER OF DESIGN SUPPORT AREA
DEPARTMENT DIRECTOR
Gloria J. Jeff

DRAWN BY: BLT

James D. Culp
ENGINEER OF TRAFFIC AND SAFETY

W. B. Blund
ENGINEER OF DEVELOPMENT

9-29-2003
F.H.W.A. APPROVAL

12-12-2002
PLAN DATE

B-39-C

SHEET
1 OF 2

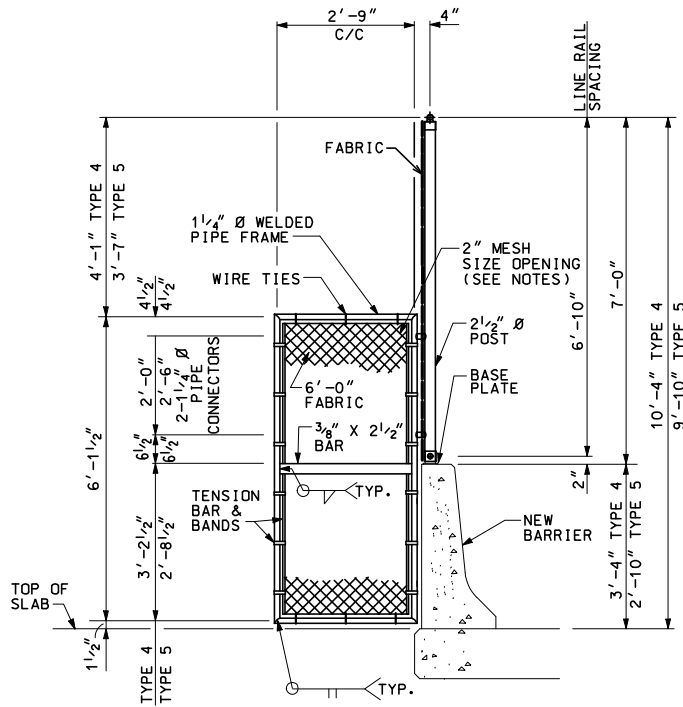

ANTI-CLIMB SHIELD/POST DETAIL

THE ANTI-CLIMB SHIELD SHALL BE LOCATED AT THE SECOND POST FROM THE END OR AS SHOWN ON THE PLANS OR AS DIRECTED BY THE ENGINEER.

NOTES:

ALL FENCE POSTS SHALL BE 2 1/2" NOMINAL, (2.875" O.D.) PIPE AND ANTI-CLIMB SHIELD PIPE FRAMES SHALL BE 1 1/4" NOMINAL, (1.66" O.D.) PIPE, IN CONFORMANCE WITH ASTM F669, CLASS 1C.

HORIZONTAL RAILS SHALL BE 1 1/4" NOMINAL (1.66" O.D.) PIPE IN CONFORMANCE WITH ASTM F669, CLASS 1C OR ASTM F1083.

ALL FENCE COMPONENTS, UNLESS OTHERWISE INDICATED, SHALL BE GALVANIZED IN ACCORDANCE WITH MDOT'S CURRENT STANDARD SPECIFICATIONS FOR CONSTRUCTION.

ALL POSTS, ANTI-CLIMB SHIELDS OR OTHER COMPONENTS TO BE FABRICATED SHALL BE FURNISHED "BLACK" AND THEN GALVANIZED AFTER FABRICATION.

DAMAGED GALVANIZED SURFACES SHALL BE REPAIRED IN CONFORMANCE WITH MDOT'S CURRENT STANDARD SPECIFICATIONS FOR CONSTRUCTION.

FENCE FABRIC SHALL BE #9 GAGE MESH AND BE GALVANIZED OR ALUMINUM COATED IN CONFORMANCE WITH MDOT'S CURRENT STANDARD SPECIFICATIONS FOR CONSTRUCTION. MESH SIZE OPENING SHALL BE 2" UNLESS 1" MESH SIZE OPENING IS APPROVED BY THE TRAFFIC AND SAFETY DIVISION AND NOTED ON DESIGN PLANS. ALL DETAILS ON STANDARD PLAN SHALL APPLY REGARDLESS OF MESH SIZE OPENINGS.

GALVANIZED 3/8" Ø TRUSS RODS SHALL EXTEND DIAGONALLY FROM THE TOP CONNECTION CLIP AT EACH TENSION BAR TO THE ADJACENT POST, EXCEPT ACROSS EXPANSION JOINTS AND AT LIGHT STANDARDS WITH A CURVED FENCE DETAIL, WHEN THERE ARE TWO OR MORE CONTINUOUS PANELS OF FABRIC.

ALL POSTS SHALL BE INSTALLED PLUMB AND MAY BE SHIMMED WITH NON-METALLIC SHIMS, APPROVED BY THE ENGINEER. COSTS FOR SHIMMING SHALL BE INCLUDED IN THE PAY ITEM "FENCE, STRUCTURE".

THE GROUND WIRE SHALL BE PLACED IN A NON-METALLIC CONDUIT, FROM THE END POST CONNECTION TO THE GROUND ROD CONNECTION. THE CONDUIT SHALL BE SECURED TO THE STRUCTURE USING EITHER EXPANSION BOLTS OR ADHESIVE ANCHORED BOLTS WITH GALVANIZED METAL STRIPS, AS APPROVED BY THE ENGINEER.

IN THE EVENT THAT INSTALLATION OF A GROUND ROD IS IMPRACTICAL, THE GROUND WIRE SHALL BE CONNECTED TO THE NEAREST LIGHT STANDARD, USING A MECHANICAL CLIP, ONLY AFTER OBTAINING PERMISSION FROM THE LOCAL PUBLIC LIGHTING AUTHORITY.

EXPANSION JOINT SLEEVES, FOR HORIZONTAL RAILS, SHALL BE THE MANUFACTURER'S STANDARD OVERSIZED SLEEVES, CRIMPED IN THE MIDDLE.

ALL LABOR, MATERIAL AND EQUIPMENT REQUIRED TO INSTALL PEDESTRIAN FENCING SHALL BE INCLUDED IN PAY ITEM "FENCE, STRUCTURE".

NO SLIP FORMING OF BRIDGE RAILING, TYPE 4 OR 5 SHALL BE ALLOWED. RAILINGS SHALL BE CAST IN PLACE.

THE U-BOLTS FOR FENCING BASE PLATES SHALL BE ACCURATELY POSITIONED ACCORDING TO THE PLANS AND FIRMLY HELD BY MEANS OF A TEMPLATE.

MICHIGAN DEPARTMENT OF TRANSPORTATION
BUREAU OF HIGHWAY DEVELOPMENT STANDARD PLAN FOR

**FENCING FOR
PEDESTRIAN STRUCTURE
NEW TYPE 4 & 5 BARRIER**

9-29-2003
F.H.W.A. APPROVAL

12-12-2002
PLAN DATE

B-39-C

SHEET
2 OF 2