

HMA SHOULDER PLAN
ADJACENT TO 12' LANE

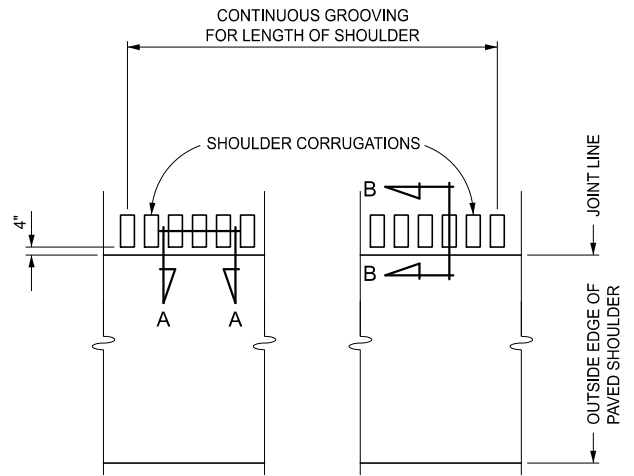

HMA SHOULDER PLAN
ADJACENT TO 14' LANE

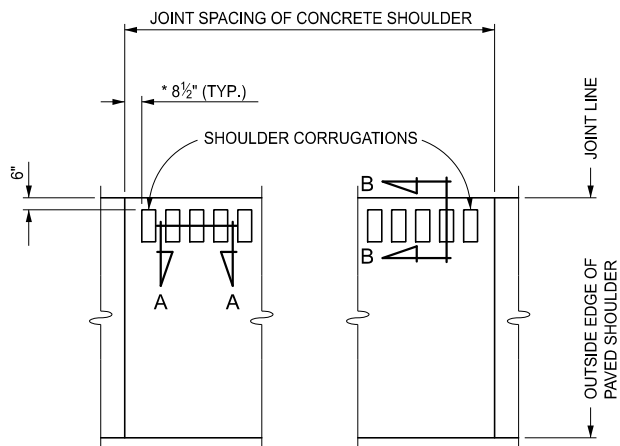

CONCRETE SHOULDER PLAN
ADJACENT TO 12' LANE

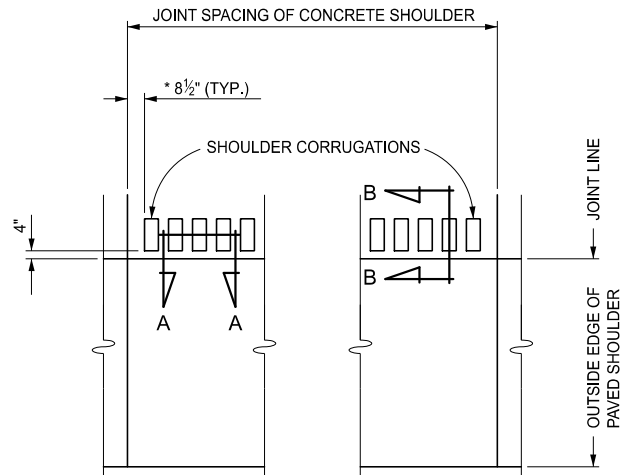

CONCRETE SHOULDER PLAN
ADJACENT TO 14' LANE

* THE DISTANCE FROM THE CORRUGATION TO THE TRANSVERSE JOINT SHALL BE AT LEAST 6" BUT LESS THAN 12".

* THE DISTANCE FROM THE CORRUGATION TO THE TRANSVERSE JOINT SHALL BE AT LEAST 6" BUT LESS THAN 12".

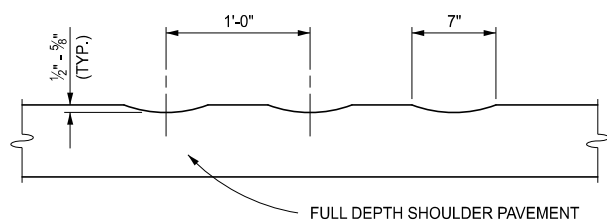

SECTION A - A

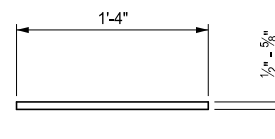

SECTION B - B

FREEWAY SHOULDER CORRUGATIONS (FOR FREEWAY SHOULDERS PAVED 4 FEET OR GREATER)

APPROVED BY: _____
DIRECTOR, BUREAU OF FIELD SERVICES

APPROVED BY: _____
DIRECTOR, BUREAU OF DEVELOPMENT



DEPARTMENT DIRECTOR
BRADLEY C. WIEFERICH, PE

STANDARD PLAN FOR SHOULDER AND CENTER LINE CORRUGATIONS

(SPECIAL DETAIL) 08/02/2023
FHWA APPROVAL PLAN DATE

R-112-J

SHEET
1 OF 10

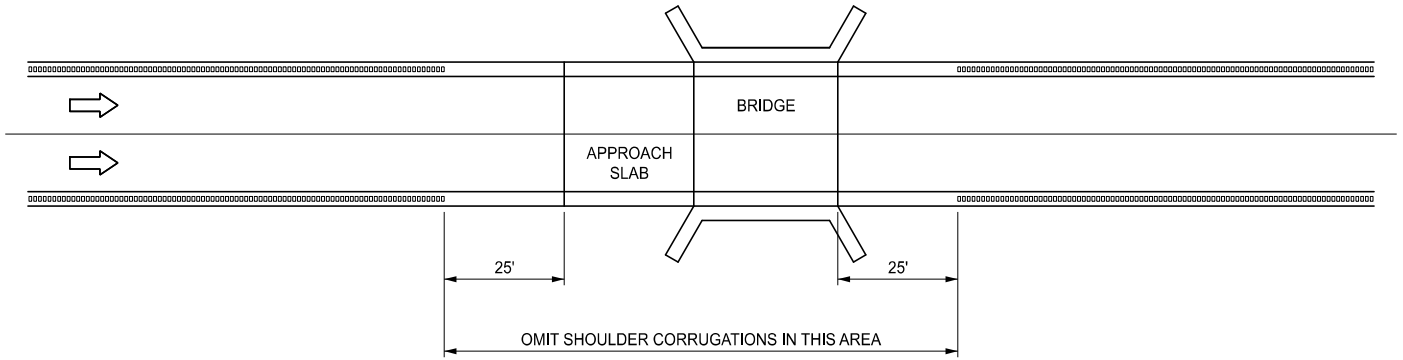

SHOULDER CORRUGATIONS AT BRIDGES
FREEWAY SHOULDER CORRUGATIONS
 (FOR FREEWAY SHOULDERS PAVED 4 FEET OR GREATER)

MDOT
 Michigan Department of Transportation

DEPARTMENT DIRECTOR
 BRADLEY C. WIEFERICH, PE

STANDARD PLAN FOR SHOULDER AND CENTER LINE CORRUGATIONS			
(SPECIAL DETAIL)	08/02/2023	R-112-J	SHEET
FHWA APPROVAL	PLAN DATE		2 OF 10

* LATERAL DEVIATION SHALL NOT EXCEED 1" IN 100'.

NOTE:

ON CONCRETE PAVEMENTS, THE DISTANCE FROM A SHOULDER CORRUGATION TO A TRANSVERSE JOINT SHALL BE AT LEAST 6" BUT LESS THAN 12".

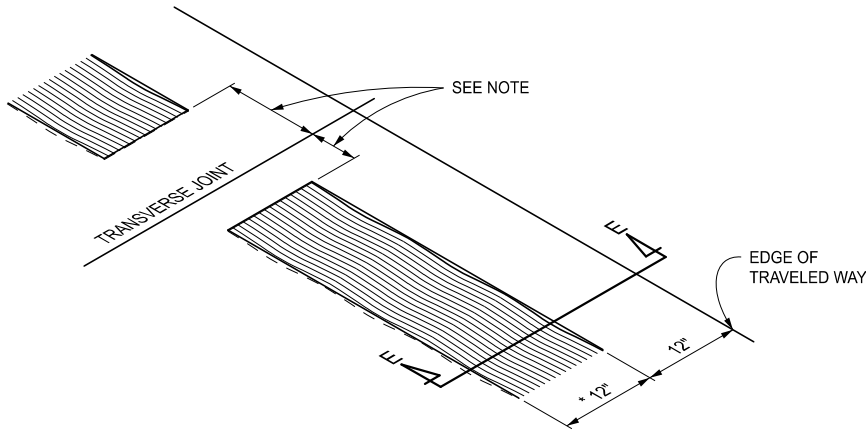

TYPICAL NON-FREEWAY SHOULDER CORRUGATION INSTALLATION

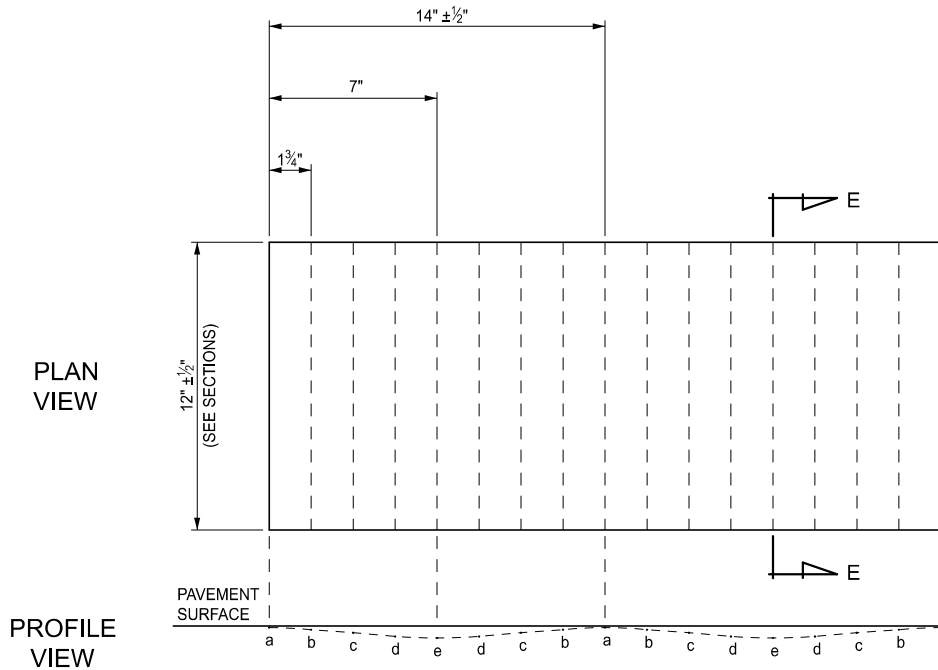

LOCATION	DEPTH AT EDGE	
	MILS	INCHES *
a	62.5	1/16
b	156	5/32
c	281	9/32
d	438	7/16
e	500	1/2

* +1/8"

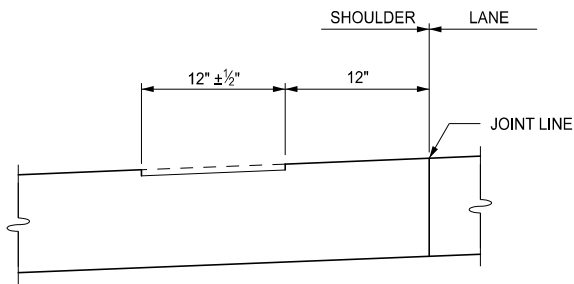

SECTION E-E
CONCRETE & HMA SHOULDER

SINUSOIDAL CORRUGATIONS

<p>DEPARTMENT DIRECTOR BRADLEY C. WIEFERICH, PE</p>	STANDARD PLAN FOR SHOULDER AND CENTER LINE CORRUGATIONS			SHEET 3 OF 10
	(SPECIAL DETAIL) FHWA APPROVAL	08/02/2023 PLAN DATE	R-112-J	

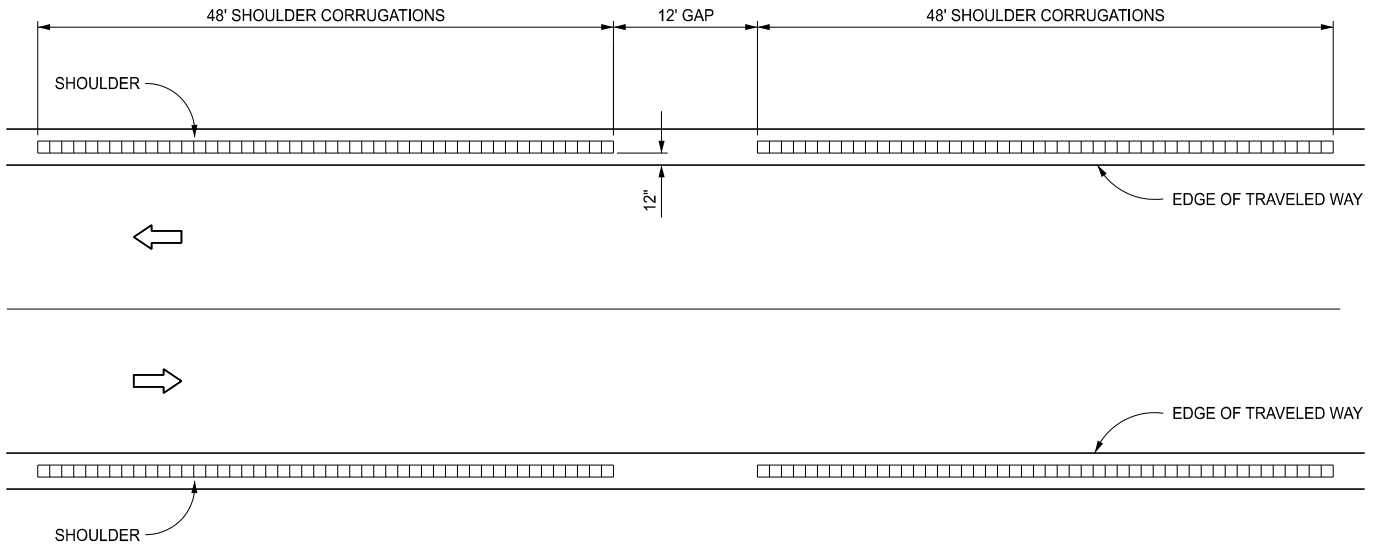

SHOULDER CORRUGATIONS ON TWO-WAY ROADWAYS

NON-FREEWAY SHOULDER CORRUGATIONS
 (FOR NON-FREEWAY SHOULDERS PAVED 6 FEET OR GREATER)

 DEPARTMENT DIRECTOR BRADLEY C. WIEFERICH, PE	STANDARD PLAN FOR SHOULDER AND CENTER LINE CORRUGATIONS			SHEET
	(SPECIAL DETAIL) FHWA APPROVAL	08/02/2023 PLAN DATE	R-112-J	4 OF 10

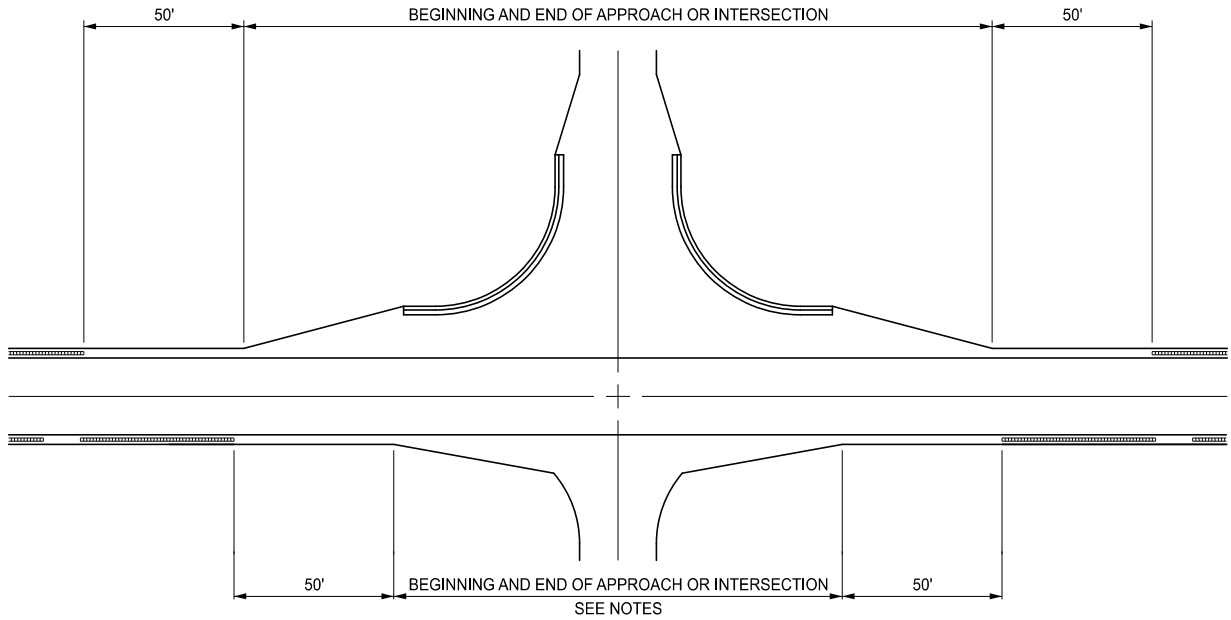

NOTE:

SHOULDER CORRUGATIONS MAY BE OMITTED IN AREAS WITH HIGH CONCENTRATIONS OF DRIVES, WHEN DIRECTED BY THE ENGINEER.

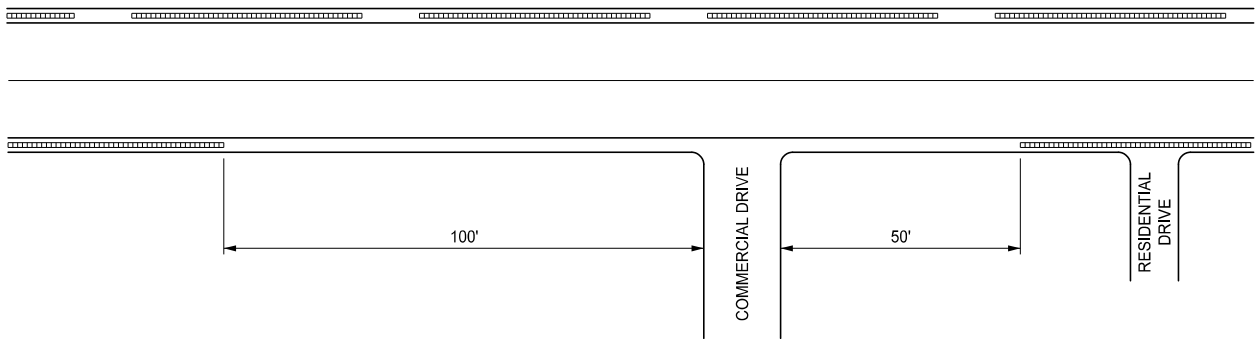

SHOULDER CORRUGATIONS AT INTERSECTIONS

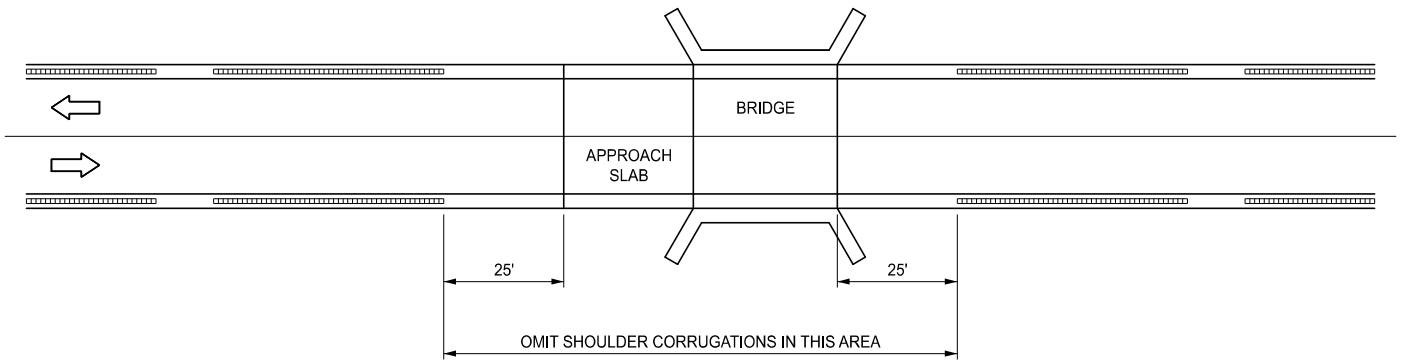

SHOULDER CORRUGATIONS AT BRIDGES

NON-FREEWAY SHOULDER CORRUGATIONS

(FOR NON-FREEWAY SHOULDERS PAVED 6 FEET OR GREATER)

<p>MDOT Michigan Department of Transportation</p> <p>DEPARTMENT DIRECTOR BRADLEY C. WIEFERICH, PE</p>	<p>STANDARD PLAN FOR SHOULDER AND CENTER LINE CORRUGATIONS</p>			<p>R-112-J</p>	<p>SHEET 5 OF 10</p>
	<p>(SPECIAL DETAIL) FHWA APPROVAL</p>	<p>08/02/2023 PLAN DATE</p>			

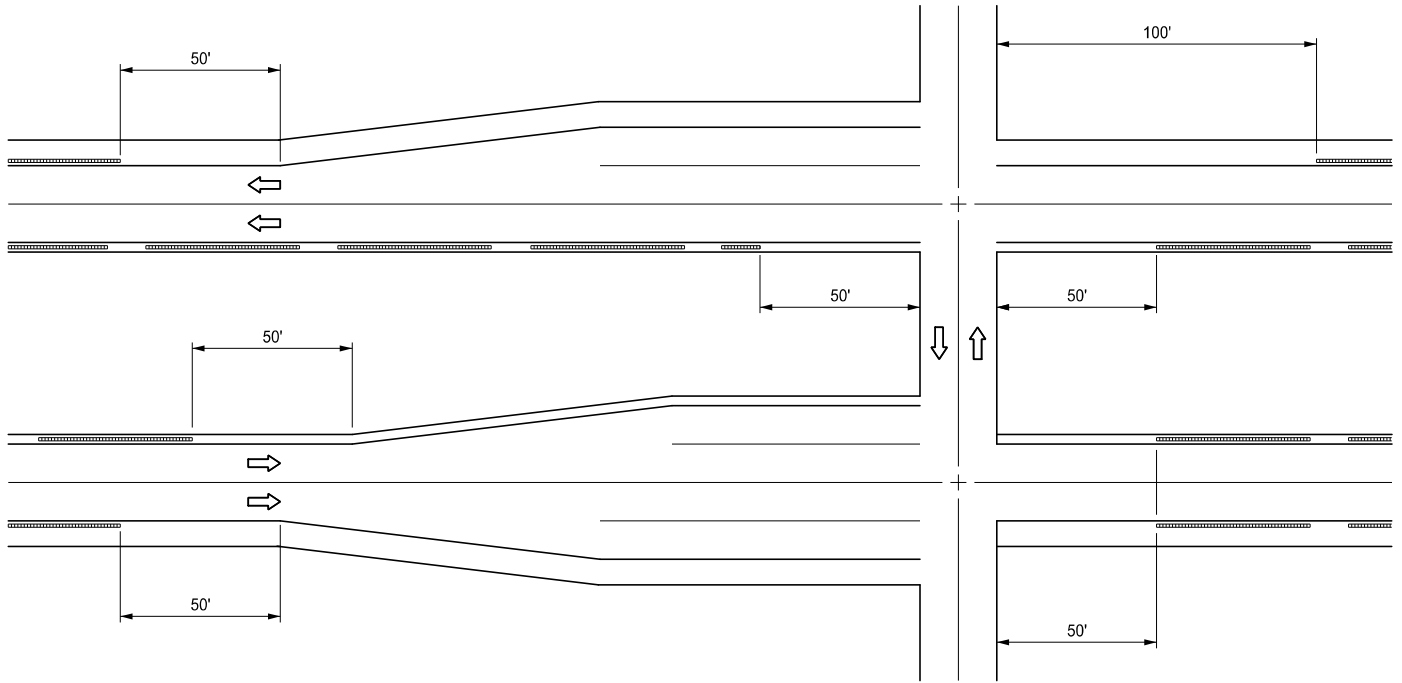

SHOULDER CORRUGATIONS AT INTERSECTIONS

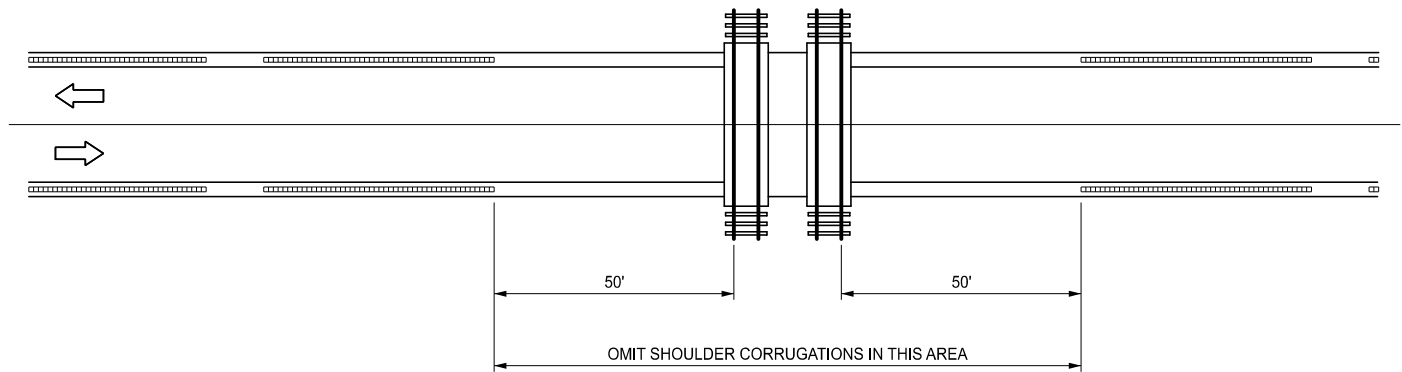

SHOULDER CORRUGATIONS AT RAILROADS

NON-FREEWAY SHOULDER CORRUGATIONS
 (FOR NON-FREEWAY SHOULDERS PAVED 6 FEET OR GREATER)

 DEPARTMENT DIRECTOR BRADLEY C. WIEFERICH, PE	STANDARD PLAN FOR SHOULDER AND CENTER LINE CORRUGATIONS			R-112-J	SHEET 6 OF 10
	(SPECIAL DETAIL) FHWA APPROVAL	08/02/2023 PLAN DATE			

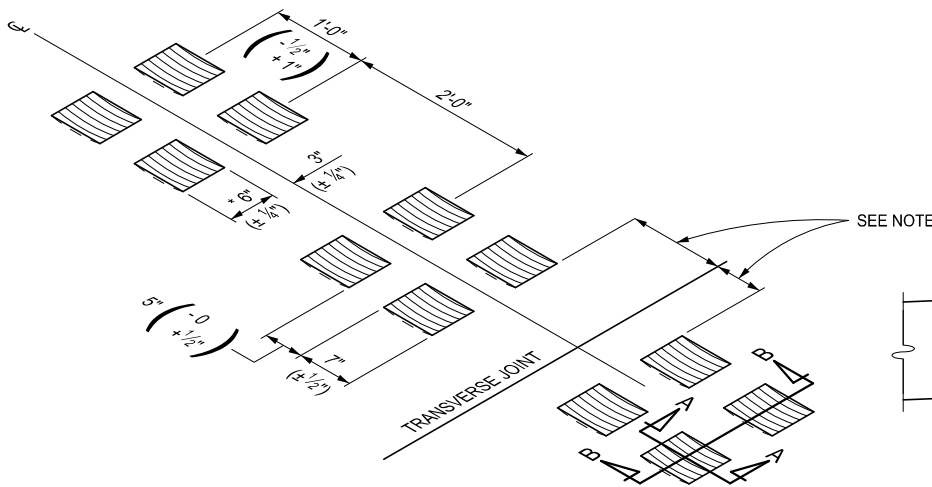

TYPICAL NON-FREEWAY CENTER LINE CORRUGATION INSTALLATION FOR CONCRETE PAVEMENT

* LATERAL DEVIATION SHALL NOT EXCEED 1" IN 100'.

NOTES:

ON CONCRETE PAVEMENTS, THE DISTANCE FROM A CENTER LINE CORRUGATION TO A TRANSVERSE JOINT SHALL BE AT LEAST 6" BUT LESS THAN 12".

ON CONCRETE PAVEMENTS, CORRUGATIONS MAY BE CONSTRUCTED IN TWO PASSES AND THEREFORE NOT BE SYMMETRICAL ACROSS THE CENTER LINE.

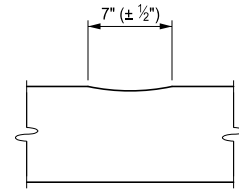

SECTION A-A

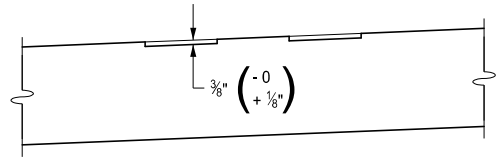

**SECTION B-B
SUPERELEVATED ROADWAY**

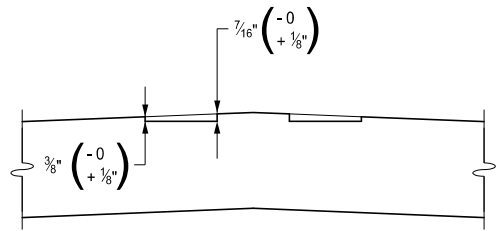

**SECTION B-B
CROWNED ROADWAY**

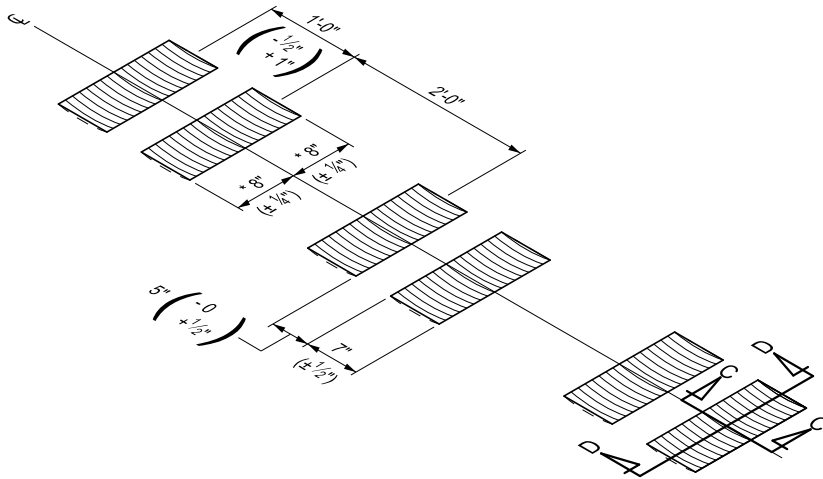

TYPICAL NON-FREEWAY CENTER LINE CORRUGATION INSTALLATION FOR HMA PAVEMENT

* LATERAL DEVIATION SHALL NOT EXCEED 1" IN 100'.

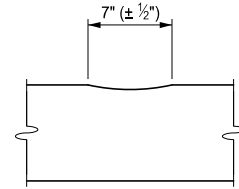

SECTION C-C

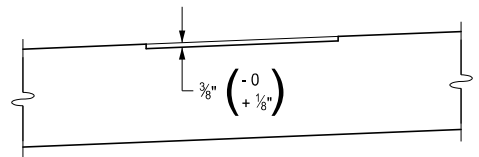

**SECTION D-D
SUPERELEVATED ROADWAY**

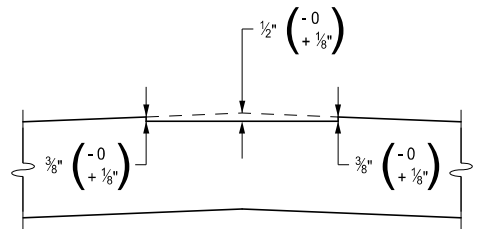

**SECTION D-D
CROWNED ROADWAY**

NON-FREEWAY CENTER LINE CORRUGATIONS

<p>MDOT Michigan Department of Transportation</p> <p>DEPARTMENT DIRECTOR BRADLEY C. WIEFERICH, PE</p>	<p>STANDARD PLAN FOR SHOULDER AND CENTER LINE CORRUGATIONS</p>			<p>R-112-J</p>	<p>SHEET 7 OF 10</p>
	<p>(SPECIAL DETAIL) FHWA APPROVAL</p>	<p>08/02/2023 PLAN DATE</p>			

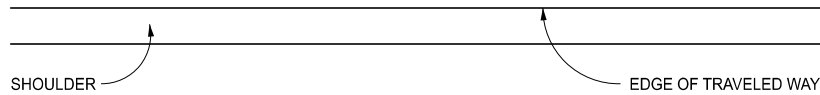
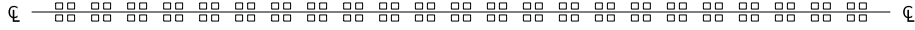
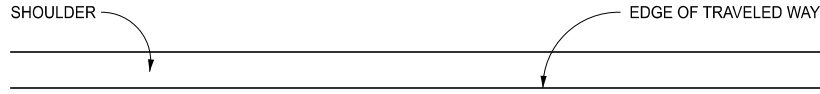

CENTER LINE CORRUGATIONS ON TWO-WAY ROADWAYS

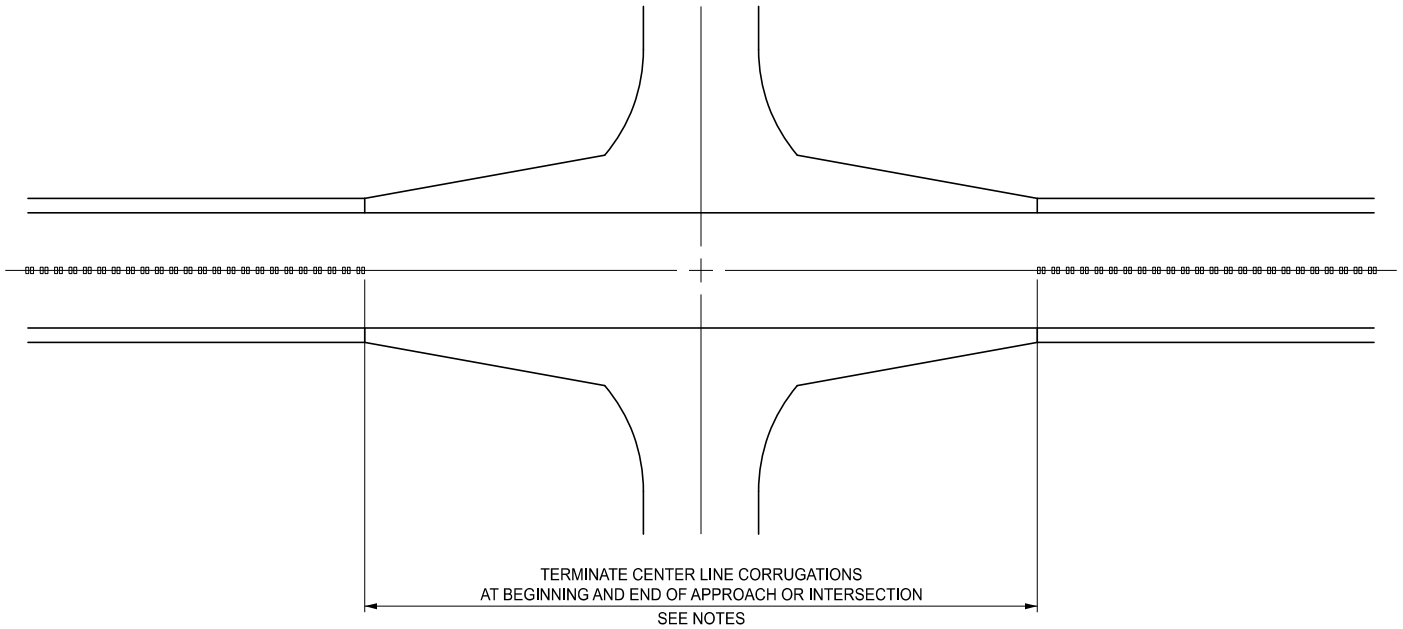

CENTER LINE CORRUGATIONS AT INTERSECTIONS

NON-FREEWAY CENTER LINE CORRUGATIONS

<p>DEPARTMENT DIRECTOR BRADLEY C. WIEFERICH, PE</p>	<p>STANDARD PLAN FOR SHOULDER AND CENTER LINE CORRUGATIONS</p>			<p>R-112-J</p>	<p>SHEET 8 OF 10</p>
	<p>(SPECIAL DETAIL) FHWA APPROVAL</p>	<p>08/02/2023 PLAN DATE</p>			

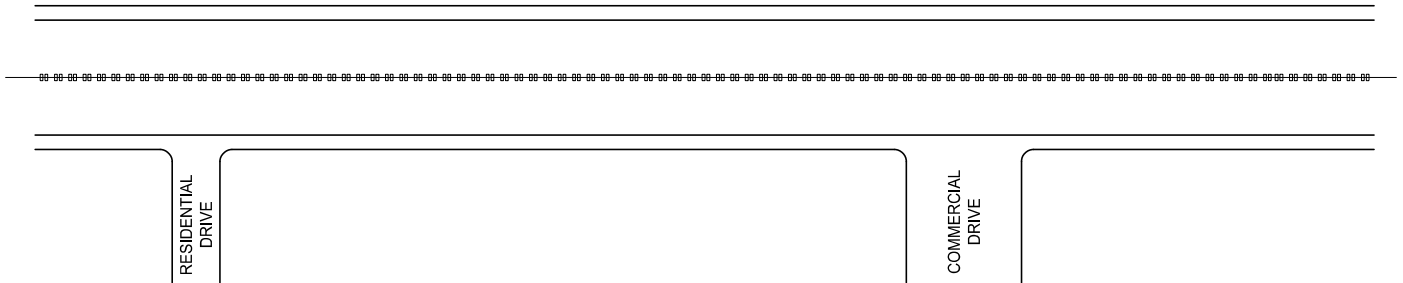

CENTER LINE CORRUGATIONS AT DRIVEWAYS

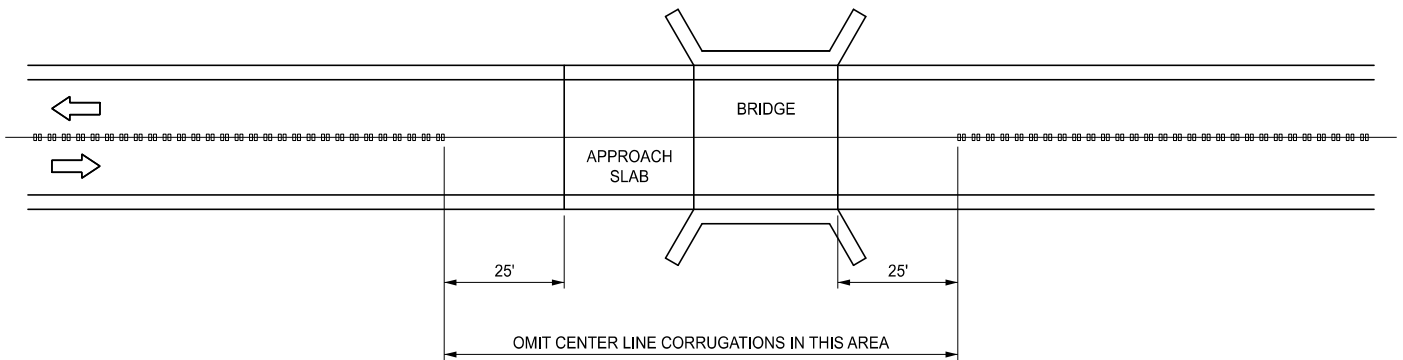

CENTER LINE CORRUGATIONS AT BRIDGES

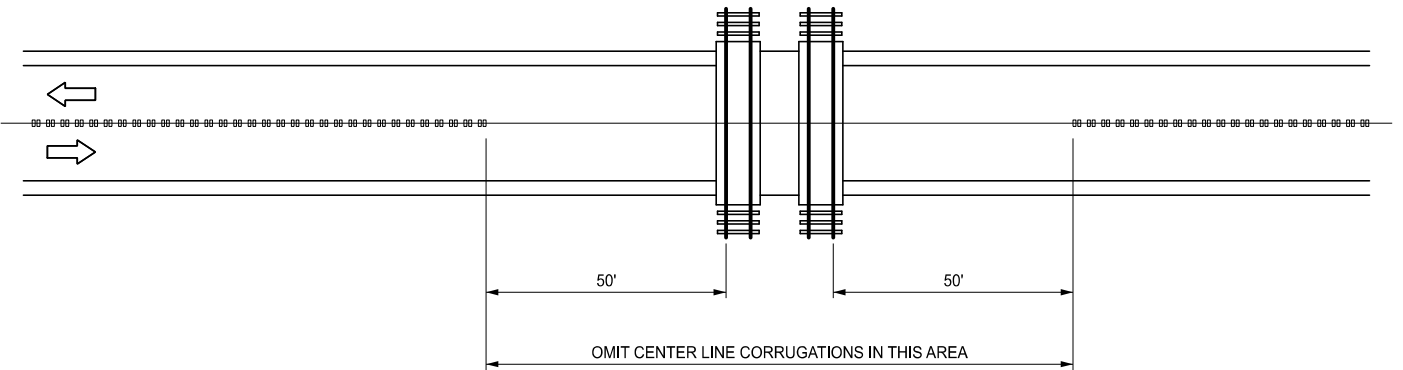

CENTER LINE CORRUGATIONS AT RAILROADS

NON-FREEWAY CENTER LINE CORRUGATIONS

 DEPARTMENT DIRECTOR BRADLEY C. WIEFERICH, PE	STANDARD PLAN FOR SHOULDER AND CENTER LINE CORRUGATIONS			R-112-J	SHEET 9 OF 10
	(SPECIAL DETAIL) FHWA APPROVAL	08/02/2023 PLAN DATE			

NOTES: (NON-FREEWAY)

SHOULDER CORRUGATION CROSS-SECTIONS AND LOCATIONS SHALL BE AS DETAILED ON THIS STANDARD. CORRUGATIONS ON NON-FREEWAYS SHALL BE IN CONCRETE AND HMA SHOULDERS PAVED AT LEAST 6'-0" WIDE WITH A POSTED SPEED OF 55 MPH. CORRUGATIONS CAN BE USED IN OTHER SITUATIONS WHERE THEY HAVE BEEN PREVIOUSLY APPROVED USING CURRENT GUIDELINES.

CORRUGATIONS SHALL NOT BE PLACED OVER A TRANSVERSE SHOULDER JOINT.

DO NOT MILL SHOULDER OR CENTER LINE CORRUGATIONS THROUGH ANY INTERSECTION, MARKED CROSSWALK, NON-MOTORIZED PATH CROSSING, OR SNOWMOBILE CROSSING.

NOTES: (FREEWAY)

SHOULDER CORRUGATION CROSS-SECTIONS AND LOCATIONS SHALL BE AS DETAILED ON THIS STANDARD. CORRUGATIONS ON FREEWAYS SHALL BE IN CONCRETE AND HMA SHOULDERS PAVED 4'-0" OR WIDER OR WHERE THE SHOULDER LIES BETWEEN THE PAVEMENT AND VALLEY GUTTER OR CURB AND GUTTER. CORRUGATIONS WILL NOT BE USED IN FREEWAY EXIT/ENTRANCE RAMP SHOULDERS OR WHERE SHOULDERS ARE SEPARATED FROM THE PAVEMENT BY VALLEY GUTTER OR CURB AND GUTTER. EXCEPT FOR LOOP RAMPS, CORRUGATIONS WILL BE USED ON FREEWAY TO FREEWAY RAMPS.

CORRUGATIONS SHALL NOT BE PLACED OVER A TRANSVERSE SHOULDER JOINT.

CORRUGATION LOCATION IN THE AREA OF FREEWAY RAMPS WILL BE AS FOLLOWS: THE TYPICAL OFFSET WILL BE INCREASED TO 24" AND BE LOCATED ON THE SHOULDER SIDE OF THE JOINT BEGINNING 300' IN ADVANCE OF THE EXIT RAMP TAPER. THIS OFFSET WILL CONTINUE UNTIL THE 2' POINT OF THE GORE. FOR EXIT/ENTRANCE RAMPS AND LOOPS RAMPS THE CORRUGATIONS WILL END ALONG THE RAMP AT THIS POINT AND SIMULTANEOUSLY RESUME ON THE MAINLINE SHOULDER AND GORE WITH THE NORMAL OFFSET. THE CONFIGURATION FOR ENTRANCE RAMPS WILL BE IN THE REVERSE ORDER OF THE EXIT RAMPS. FOR FREEWAY TO FREEWAY RAMPS, IN ADDITION TO RESUMING THE MAINLINE SHOULDER CORRUGATION AT THIS POINT, RETURN TO THE NORMAL MAINLINE OFFSET ALONG THE LENGTH OF THE RAMP SHOULDER.

WITHIN AN URBAN FREEWAY AREA OR OTHER LIMITED FREEWAY AREA, SHOULDER CORRUGATIONS MAY BE OFFSET UP TO 12" FROM THE EDGE OF THE TRAVEL LANE, AS SHOWN IN THE PLANS, OR AS DIRECTED BY THE ENGINEER. IF NEEDED, THE CORRUGATION MAY BE LOCATED ON THE OPPOSITE SIDE OF THE JOINT FOR 14' LANES TO MAINTAIN THE MINIMUM OFFSET TO THE JOINT LINE.



DEPARTMENT DIRECTOR
BRADLEY C. WIEFERICH, PE

STANDARD PLAN FOR
SHOULDER AND CENTER LINE CORRUGATIONS

(SPECIAL DETAIL)
FHWA APPROVAL

08/02/2023
PLAN DATE

R-112-J

SHEET
10 OF 10