

ELEVATION

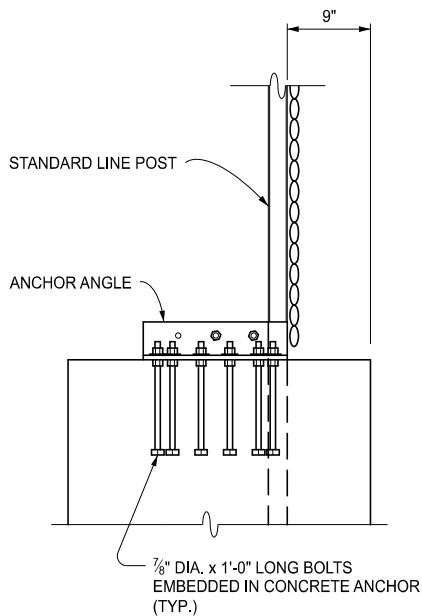

END VIEW OF CONCRETE ANCHOR
CONCRETE QUANTITY FOR ANCHOR = 0.5 CYD

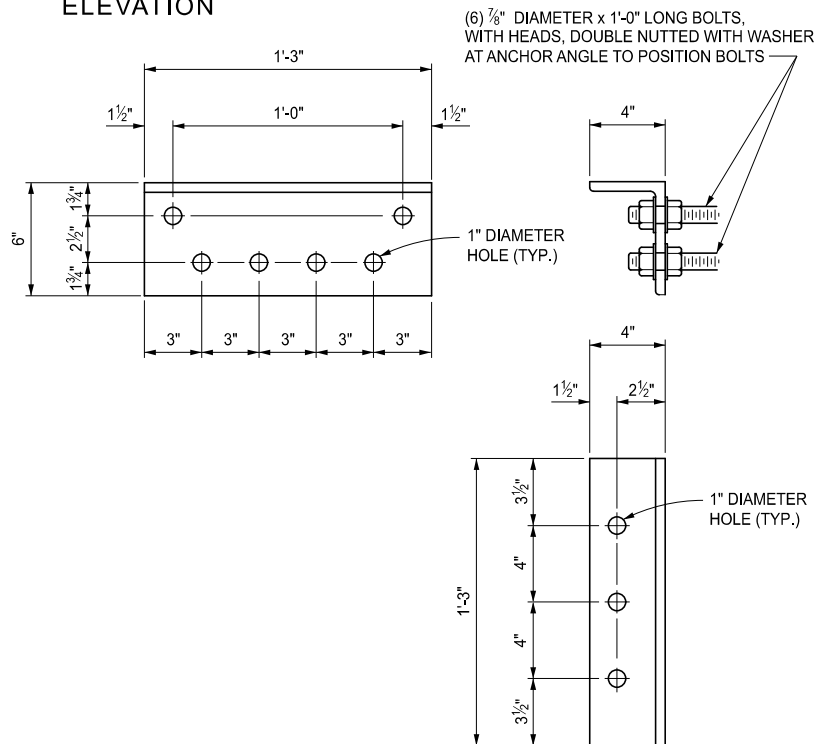

L6" x 4" x 1/2" x 1'-3" LONG ANCHOR ANGLE

APPROVED BY: _____
DIRECTOR, BUREAU OF FIELD SERVICES

APPROVED BY: _____
DIRECTOR, BUREAU OF DEVELOPMENT



DEPARTMENT DIRECTOR
BRADLEY C. WIEFERICH, PE

SPECIAL DETAIL FOR
CHAIN LINK FENCE WITH WIRE ROPE

(SPECIAL DETAIL)
FHWA APPROVAL

12/06/2022
PLAN DATE

SPECIAL DETAIL 99

SHEET
1 OF 2

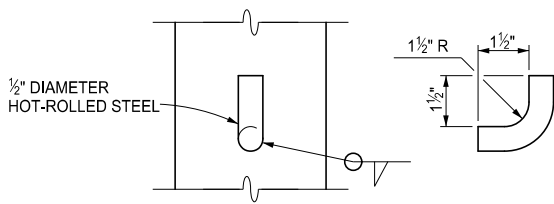

1/2" DIAMETER HOT ROLLED BAR

NOTE:
THE WELDED 1/2" DIAMETER HOT-ROLLED BAR AND THE WIRE ROPE SHALL BE FASTENED TO THE LINE POSTS THAT ARE SPECIFIED ON STANDARD PLAN R-98-SERIES.

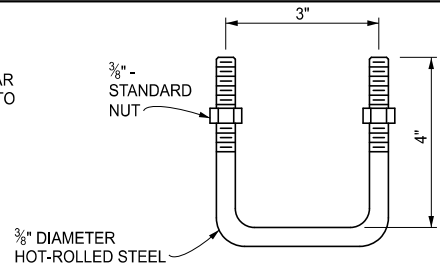

U-BOLT WITH NUTS

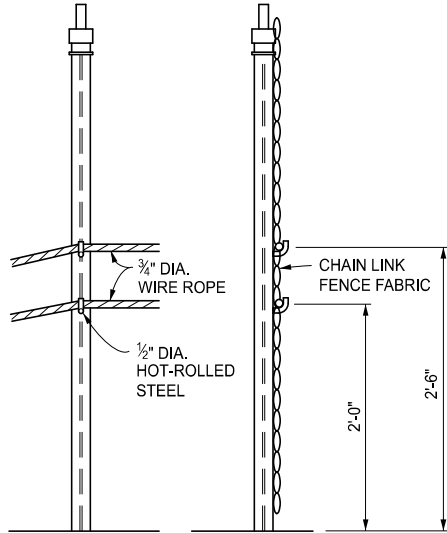

1st POST FROM ANCHOR

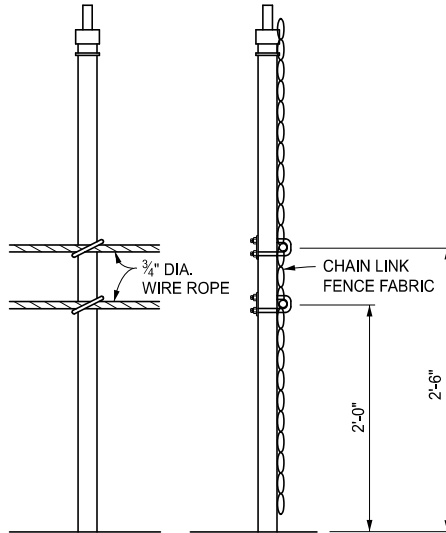

WIRE ROPE INSTALLED TO LINE POST WITH U-BOLTS

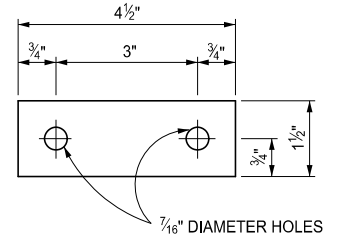

U-BOLT WASHER
1/4" THICK HOT-ROLLED STEEL



3/4" DIAMETER WIRE ROPE (3 x 7)

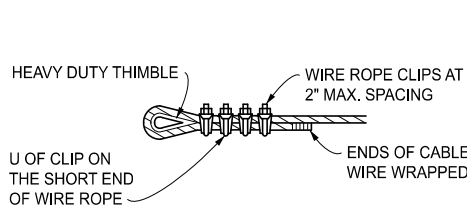

WIRE ROPE LOOP ENDING

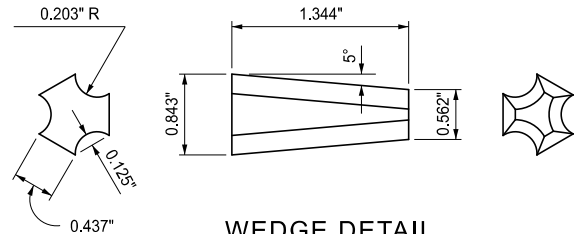

WEDGE DETAIL

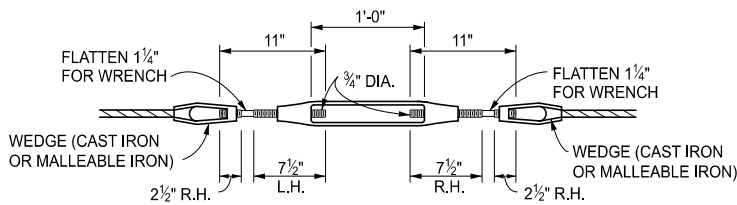

TURNBUCKLE WIRE ROPE ASSEMBLY

NOTES:

CHAIN LINK FENCE WITH WIRE ROPE SHALL BE INSTALLED ACCORDING TO THIS PLAN AND STANDARD PLAN R-98-SERIES. THE WIRE ROPE SHALL BE ANCHORED ACCORDING TO THIS PLAN AND INSTALLED ON STANDARD FENCE POSTS FOR CHAIN LINK FENCE WITH CHAIN LINK FABRIC PLACED ON THE INSIDE OF WIRE ROPE. THE POST NEXT TO THE ANCHORAGE REQUIRES SPECIAL FABRICATION (SEE DETAIL). ALTERNATE DESIGNS MAY BE SUBMITTED TO THE ENGINEER FOR CONSIDERATION AND APPROVAL.

ALL POSTS, WIRE ROPES, AND FITTINGS SHALL BE GALVANIZED ACCORDING TO THE STANDARD SPECIFICATIONS FOR CONSTRUCTION.

ALL WELDING SHALL BE DONE ACCORDING TO THE STANDARD SPECIFICATIONS FOR CONSTRUCTION. TURNBUCKLES SHALL BE OF THE OPEN TYPE AND SHALL EACH PROVIDE A MINIMUM TAKEUP OF 1'-0".

ANCHORAGE SHALL BE PROVIDED ON EACH END OF CABLES WITH ONE TURNBUCKLE FOR EACH 500' RUN OF WIRE ROPE. MAXIMUM DISTANCE BETWEEN ANCHORAGES SHALL BE 1000'. WHEN PLACING WIRE ROPE IN EXISTING FENCE, THE CONCRETE ANCHORS MAY BE PLACED 2'-0" BEYOND THE 10'-0" TYPICAL POST SPACING, LEAVING THE EXISTING POST IN PLACE.

TENSION WIRE AND WIRE ROPES SHALL BE STRETCHED TAUT.

TOP AND BOTTOM SELVAGES OF FENCE FABRIC SHALL HAVE A KNUCKLED FINISH.

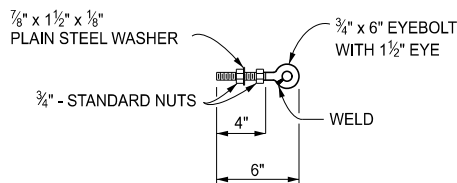

WELDED EYE-BOLT WITH NUTS & WASHER



DEPARTMENT DIRECTOR
BRADLEY C. WIEFERICH, PE

SPECIAL DETAIL FOR
CHAIN LINK FENCE WITH WIRE ROPE

(SPECIAL DETAIL)
FHWA APPROVAL

12/06/2022
PLAN DATE

SPECIAL DETAIL 99

SHEET
2 OF 2