

**TYPICAL ELEVATIONS**

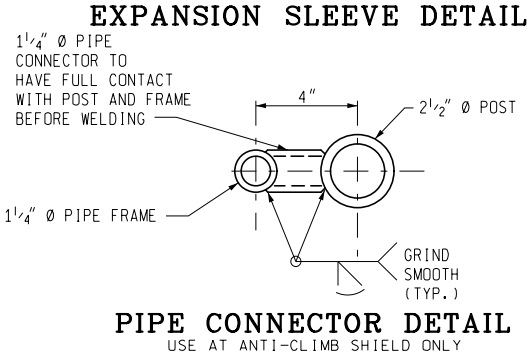
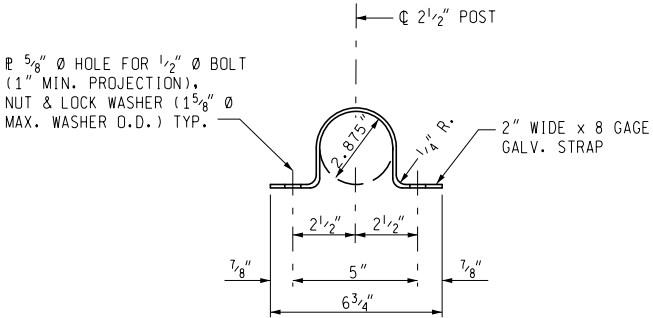
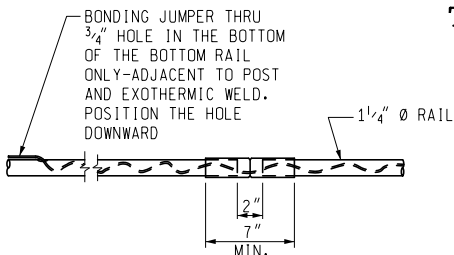

**POST CONNECTION CLIP DETAIL**

**MDOT**  
Michigan Department of Transportation

PREPARED BY  
DESIGN DIVISION

DRAWN BY: BLT

CHECKED BY: VZ

DEPARTMENT DIRECTOR  
Kirk T. Stuedle

APPROVED BY: *Randy V. ...*  
DIRECTOR, BUREAU OF FIELD SERVICES

APPROVED BY: *Mark A. Van ...*  
DIRECTOR, BUREAU OF HIGHWAY DEVELOPMENT

MICHIGAN DEPARTMENT OF TRANSPORTATION  
BUREAU OF HIGHWAY DEVELOPMENT STANDARD PLAN FOR

**FENCING FOR  
PEDESTRIAN STRUCTURE  
EXISTING TYPE 4 & 5 BARRIER**

1-25-2013 F.H.W.A. APPROVAL	4-15-2009 PLAN DATE	<b>B-38-D</b>	SHEET 1 OF 2
--------------------------------	------------------------	---------------	-----------------

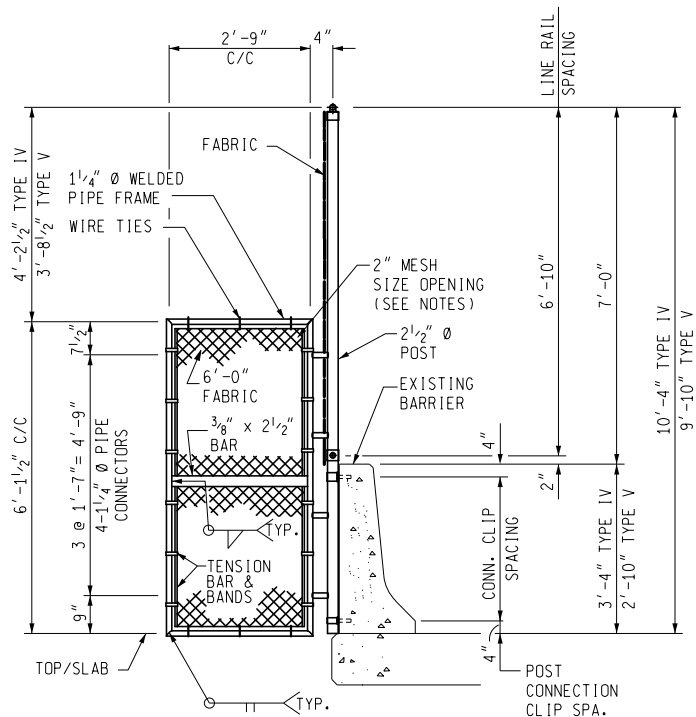

### ANTI-CLIMB SHIELD/POST DETAIL

THE ANTI-CLIMB SHIELD SHALL BE LOCATED AT THE SECOND POST FROM THE END OR AS SHOWN ON THE PLANS OR AS DIRECTED BY THE ENGINEER.

#### NOTES:

ALL FENCE POSTS SHALL BE 2 1/2" NOMINAL, (2.875" O.D.) PIPE AND ANTI-CLIMB SHIELD PIPE FRAMES SHALL BE 1 1/4" NOMINAL, (1.66" O.D.) PIPE, IN CONFORMANCE WITH ASTM F669, CLASS 1C.

HORIZONTAL RAILS SHALL BE 1 1/4" NOMINAL (1.66" O.D.) PIPE IN CONFORMANCE WITH ASTM F669, CLASS 1C OR ASTM F1083.

ALL FENCE COMPONENTS, UNLESS OTHERWISE INDICATED, SHALL BE GALVANIZED IN ACCORDANCE WITH MDOT'S CURRENT STANDARD SPECIFICATIONS FOR CONSTRUCTION.

ALL POSTS, ANTI-CLIMB SHIELDS OR OTHER COMPONENTS TO BE FABRICATED SHALL BE FURNISHED "BLACK", FABRICATED (WELDED) AND THEN GALVANIZED.

DAMAGED GALVANIZED SURFACES (NEW AND EXISTING) SHALL BE REPAIRED IN CONFORMANCE WITH MDOT'S CURRENT STANDARD SPECIFICATIONS FOR CONSTRUCTION.

FENCE FABRIC SHALL BE #9 GAGE MESH AND BE GALVANIZED OR ALUMINUM COATED IN CONFORMANCE WITH MDOT'S CURRENT STANDARD SPECIFICATIONS FOR CONSTRUCTION. MESH SIZE OPENING SHALL BE 2" UNLESS 1" MESH SIZE OPENING IS APPROVED BY THE TRAFFIC AND SAFETY DIVISION AND NOTED ON DESIGN PLANS. ALL DETAILS ON STANDARD PLAN SHALL APPLY REGARDLESS OF MESH SIZE OPENINGS.

GALVANIZED 3/8" Ø TRUSS RODS SHALL EXTEND DIAGONALLY FROM THE TOP CONNECTION CLIP AT EACH TENSION BAR TO THE ADJACENT POST, EXCEPT ACROSS EXPANSION JOINTS AND AT LIGHT STANDARDS WITH A CURVED FENCE DETAIL, WHEN THERE ARE TWO OR MORE CONTINUOUS PANELS OF FABRIC.

ALL BOLT FASTENERS SECURED IN CONCRETE SHALL BE 1/2" DIAMETER "ADHESIVE ANCHORED BOLTS" WITH 4 1/2" EMBEDMENT. THE STRUCTURAL ADHESIVE SHALL BE CHOSEN FROM THE QUALIFIED PRODUCTS LIST IN THE CURRENT MDOT MATERIALS SOURCE GUIDE.

THE HOLE SIZE FOR ADHESIVE ANCHORED BOLTS SHALL BE PROPOSED BY THE CONTRACTOR IN ACCORDANCE WITH THE ADHESIVE BONDING AGENT MANUFACTURER'S RECOMMENDATION AND FIELD TESTED IN ACCORDANCE WITH MDOT'S CURRENT STANDARD SPECIFICATIONS FOR CONSTRUCTION.

THE CONTRACTOR IS TO PROVIDE EITHER A PLATFORM OR OTHER MEANS OF ACCESS FOR THE INSPECTION AND/OR TESTING OF THE ADHESIVE ANCHORED BOLTS. ALL LABOR, MATERIALS, AND EQUIPMENT NEEDED FOR THE ERECTION, MAINTENANCE, AND REMOVAL OF THE PLATFORM, OR OTHER MEANS OF ACCESS, SHALL BE INCLUDED IN THE PAY ITEM "FENCE, STRUCTURE".

THE CONTRACTOR SHALL FOLLOW THE MANUFACTURER'S INSTALLATION PROCEDURES WHEN INSTALLING THE ADHESIVE ANCHORED BOLTS.

ALL POSTS SHALL BE INSTALLED PLUMB AND MAY BE SHIMMED WITH NON-METALLIC SHIMS, APPROVED BY THE ENGINEER. COSTS FOR SHIMMING SHALL BE INCLUDED IN THE PAY ITEM "FENCE, STRUCTURE".

THE GROUND WIRE SHALL BE PLACED IN A NON-METALLIC CONDUIT, FROM THE END POST CONNECTION TO THE GROUND ROD CONNECTION. THE CONDUIT SHALL BE SECURED TO THE STRUCTURE USING EITHER EXPANSION BOLTS OR ADHESIVE ANCHORED BOLTS WITH GALVANIZED METAL STRIPS, AS APPROVED BY THE ENGINEER.

IN THE EVENT THAT INSTALLATION OF A GROUND ROD IS IMPRACTICAL, THE GROUND WIRE SHALL BE CONNECTED TO THE NEAREST LIGHT STANDARD, USING A MECHANICAL CLIP, ONLY AFTER OBTAINING PERMISSION FROM THE LOCAL PUBLIC LIGHTING AUTHORITY.

EXPANSION JOINT SLEEVES, FOR HORIZONTAL RAILS, SHALL BE THE MANUFACTURER'S STANDARD OVERSIZED SLEEVES, CRIMPED IN THE MIDDLE.

ALL LABOR, MATERIAL AND EQUIPMENT REQUIRED TO INSTALL PEDESTRIAN FENCING SHALL BE INCLUDED IN PAY ITEM "FENCE, STRUCTURE".

MICHIGAN DEPARTMENT OF TRANSPORTATION  
BUREAU OF HIGHWAY DEVELOPMENT STANDARD PLAN FOR

## FENCING FOR PEDESTRIAN STRUCTURE EXISTING TYPE 4 & 5 BARRIER

1-25-2013  
F.H.W.A. APPROVAL

4-15-2009  
PLAN DATE

B-38-D

SHEET  
2 OF 2