

**MICHIGAN DESIGN MANUAL
ROAD DESIGN**

CHAPTER 7

INDEX

APPURTENANCES

7.01 ROADSIDE SAFETY BARRIER

- 7.01.01 References
- 7.01.02 Application of Section 7.01
- 7.01.03 History of Guardrail and Barrier in Michigan
- 7.01.04 Section Deleted
- 7.01.05 Basic Concepts for Roadside Control
- 7.01.06 Guardrail Worksheet
- 7.01.10 Clear Zone - History
- 7.01.11 Current Clear Zone Criteria
 - A. Treatment/Considerations of Obstacles Outside the Calculated Project Clear Zone
 - B. Treatment/Considerations of Obstacles Inside the Calculated Project Clear Zone
 - C. Clear Zone Distance Chart
 - D. Curve Correction Factors Table
 - E. Other Controlling Factors
- 7.01.12 Types of Guardrail Used in Michigan
- 7.01.13 Curved Beam Elements
- 7.01.14 Guardrail Surface Finish
 - A. Galvanized
 - B. Unpainted Corrosion Resistant
 - C. Corrosion-Resistant Guardrail Replacement Policy
- 7.01.15 Guardrail Terminals
- 7.01.16 Guardrail Attachment to Bridges and Walls
- 7.01.17 Strength Requirements of Steel Beam Guardrail
- 7.01.18 Suggested Shy Line Offset Values

MICHIGAN DESIGN MANUAL

ROAD DESIGN

CHAPTER 7 APPURTENANCES INDEX (continued)

- 7.01.19 Suggested Runout Lengths for Barrier Design
- 7.01.20 Guardrail Deflection
- 7.01.21 Guardrail Strength Transitions
- 7.01.22 Minimum Guardrail Lengths and Gaps
- 7.01.23 Function of Guardrail Components
- 7.01.24 Accommodation of Expansion
- 7.01.25 Guardrail Approach Terminals
 - A. Type 1 Terminals
 - B. Type 2 Terminals
 - C. Function of the Various Guardrail Terminal Components
 - D. Guardrail Full Strength Point
 - E. Clear Area Behind Guardrail Terminals
 - F. Burying Ending in a Backslope
 - G. Slope Under Guardrail Terminals
- 7.01.29 Guardrail Flare
 - A. Flare Rate
 - B. Uniform Flare from Structures
- 7.01.30 Guardrail at Embankments
 - A. Height-Slope Guidelines
 - B. Location on Fill Sections (New Construction)
 - C. Maximum Height of 1:2 Slope Without Barrier
 - D. Flattening Slopes to Eliminate Guardrail
 - E. Length of Barrier at Embankments (New Construction)
 - F. Length of Barrier at Embankments (Upgrading Projects)
 - G. Placing Beam Guardrail on a Downslope
 - H. Guardrail Placed near Intersecting Streets and Driveways
- 7.01.31 Shielding Bodies of Water
- 7.01.32 Barrier at Bridge Approaches (Over and Under)
 - A. Attachment to Barriers and Closer Post Spacing
 - B. Relationship Between Bridge Sidewalk and Approach Guardrail
 - C. Barrier at the Trailing End of Overpassing Structures
 - D. Shielding Requirements at Bridge Underpasses
 - E. Guardrail Median Object Protection
 - F. Bridge Columns and Foundations in 70' Medians
- 7.01.33 Maintaining Guardrail Strength When One or More Posts Must be Omitted
 - A. Downspout Headers
 - B. Wide Culverts
 - C. Placing Guardrail in Rock
 - D. Guardrail Posts through Paved Surfaces
 - E. Additional Blockouts on Guardrail Posts

MICHIGAN DESIGN MANUAL

ROAD DESIGN

CHAPTER 7 APPURTENANCES INDEX (continued)

- 7.01.34 Guardrail in Conjunction with Curb
- 7.01.40 Guardrail Posts for Roadside Control
- 7.01.41 Upgrading and Replacement of Guardrail
 - A. Guidelines for Upgrading or Replacing Guardrail
 - B. Upgrading Guardrail Terminals
 - C. Intermixing Wood and Steel Posts
 - D. Guardrail Posts at or near the Shoulder Hinge Line
 - E. Allowable Variation from Standard Height
 - F. Unpainted Corrosion Resistant Beam Elements
 - G. Thick Shoulder Lifts
 - H. Type A Guardrail Parallel to Continuous Abutment, Twin Overpassing Structures
 - I. Replacing with Thrie Beam Guardrail
- 7.01.43 Guidelines for Bridge Railing Replacement and Attached Approach and Trailing Guardrails
- 7.01.44 Guardrail Upgrading on Local Roads
 - A. Guardrail Upgrading Guidelines on Local Roads (In Conjunction with Freeway Work)
 - B. Cul-de-sacs
 - C. Guardrail at Urban Service Road "T"
 - D. Cable on Chain Link Fence
- 7.01.45 Alternative Barrier End Treatments
 - A. X-TENUator
 - B. QuadTrend
 - C. BEAT-SSCC
- 7.01.50 Temporary Beam Guardrail
- 7.01.54 Warrants for Median Barriers for Freeways
- 7.01.55 Median Barriers Types
 - A. Concrete Median Barrier
 - B. Double Steel Beam Guardrail
 - C. Cable Barrier
- 7.01.56 Concrete Median Barrier
 - A. GM Shape
 - B. New Jersey Shape
 - C. Single Slope
- 7.01.57 Ending Concrete Barrier
- 7.01.58 Two Types of Concrete Median Barrier Footings

MICHIGAN DESIGN MANUAL

ROAD DESIGN

CHAPTER 7 APPURTENANCES INDEX (continued)

- 7.01.59 Concrete Glare Screen
- 7.01.60 Retrofitting Concrete Median Barrier
- 7.01.65 Concrete Median Barrier Between Roadways of Different Elevations
- 7.01.66 Concrete Barrier, Single Face
- 7.01.67 Temporary Barrier
 - A. Temporary Concrete Barrier
 - B. Temporary Steel Barrier
 - C. Portable Water Filled Barrier
 - D. Temporary Barrier Quantities and Specifications
- 7.01.68 Ending Temporary Barrier
 - A. Temporary Concrete Barrier and Temporary Steel Barrier
 - B. Portable Water Filled Barrier
- 7.01.69 Temporary Barrier at Bridge Deck and Railing Reconstruction
- 7.01.70 Temporary Barrier Adjacent to a Precipitous Drop-off
 - A. Detail 1, Standard Plan R-53-Series: Box Beam Stiffened Method
 - B. Detail 2, Standard Plan R-53-Series: Staked Method
 - C. Detail 3A, Standard Plan R-53-Series: Through Bolt Method on Concrete Bridge Deck
 - D. Detail 3B, Standard Plan R-53-Series: Through Bolt Method on Concrete Bridge Deck with an HMA Overlay
 - E. Detail 4A, Standard Plan R-53-Series: Drilled and Grouted Method on Concrete Roadway or Concrete Bridge Deck
 - F. Detail 4B, Standard Plan R-53-Series: Drilled and Grouted Method on Concrete Roadways with an HMA Overlay
 - G. Placing Limited Deflection Temporary Barrier Over Bridge Deck Expansion Joints
- 7.01.75 Concrete Filler Walls

7.02 IMPACT ATTENUATORS

7.03 GLARE SCREEN

- 7.03.01 References
- 7.03.02 General
- 7.03.03 Criterion for Use

MICHIGAN DESIGN MANUAL

ROAD DESIGN

CHAPTER 7 APPURTENANCES INDEX (continued)

7.04 PAVEMENT MARKINGS

- 7.04.01 General
- 7.04.02 Temporary Pavement Markings
- 7.04.03 Section Deleted
- 7.04.04 Removing Permanent Pavement Markings
- 7.04.05 Statutory Participating Cities
- 7.04.06 Plan Sheets, Standards Referencing, and Witness, Log, \$1,250.00
- 7.04.07 Recessing Permanent Pavement Markings
- 7.04.08 Longitudinal Pavement Markings in Work Zones Outside of Project Limits

7.05 TRAFFIC SIGNS AND ROADWAY DELINEATORS

- 7.05.01 Traffic Signs
- 7.05.02 Delineators

7.06 FENCING

- 7.06.01 References
- 7.06.02 Purpose of Fence
- 7.06.03 Types of Fence
 - A. Woven Wire Fence
 - B. Chain Link Fence
 - C. High Tensile Eight Wire Fence
- 7.06.04 Location of Fence
- 7.06.05 Use of Barbed Wire
- 7.06.06 Chain Link Fence
- 7.06.07 Gates in Chain Link Fence
- 7.06.08 Fencing Clear Vision Areas
- 7.06.09 Fencing Scenic Strips
- 7.06.10 Fencing Borrow Area Lakes and Retention Basins

MICHIGAN DESIGN MANUAL

ROAD DESIGN

CHAPTER 7 APPURTENANCES INDEX (continued)

- 7.06.11 Fence Between Twin Overpassing Structures
- 7.06.12 Guardrail in Conjunction With Fence
- 7.06.13 Temporary Fence
- 7.06.14 Protective Fence
- 7.06.15 Removing Fence
- 7.06.16 Screening Fence

7.07 NOISE BARRIERS

- 7.07.01 References
- 7.07.02 General
- 7.07.03 Technical Aspects of Sound Transmission
- 7.07.04 Current Requirements and Practices
- 7.07.05 Process for Type I Projects
- 7.07.06 Process for Type II Projects
- 7.07.07 Design Considerations for Noise Barriers
- 7.07.08 Section Deleted
- 7.07.09 Section Deleted

7.08 MAILBOX POSTS

- 7.08.01 References
- 7.08.02 General
- 7.08.03 Design Considerations

7.09 CONCRETE STEPS

- 7.09.01 General

7.10 LANDSCAPING GUIDELINES IN MDOT RIGHT-OF-WAY

MICHIGAN DESIGN MANUAL ROAD DESIGN

CHAPTER 7

APPURTENANCES

7.01

ROADSIDE SAFETY BARRIERS

7.01.01 (revised 4-24-2023)

References

- A. *A Guide to Standardized Highway Barrier Rail Hardware*, AASHTO-AGC-ARTBA Joint Committee, 1995
- B. *Roadside Design Guide*, AASHTO, 2011, 4th edition

In addition, there are a number of National Cooperative Highway Research Program (NCHRP) research publications and reports of the major research and testing agencies that are available either within the Design Division or in the Transportation Library.

7.01.02 (revised 10-22-99)

Application of Section 7.01

In writing this portion of Chapter 7 it should be noted that the concepts presented will not necessarily be considered as absolutes to be rigidly adhered to, but will be considered as an aid to enhance the engineering judgement of the designer. Even when the word "should" is used, it is recognized that there may be circumstances unique to a situation that will suggest, or even dictate, alteration of a recommended treatment.

It is also intended that the barrier treatments recommended will be applicable to state trunkline projects and not necessarily to local government projects, except as local agencies wish to incorporate them.

7.01.03 (revised 8-21-2017)

History of Guardrail and Barrier in Michigan

The practice of placing an artificial obstruction to prevent an errant vehicle from going down a steep embankment or into an area of water probably originated in the 1920's in the form of a line of posts placed at the edge of the shoulder. At some point in time the system was improved by the addition of connecting planks, which in turn were replaced by a more maintenance-free system of two steel cables. This design is illustrated on the old E-4-A-75 Series of standard plans. Following World War II some metal beam designs were introduced. One that found limited use in Michigan was the Tuthill Highway Guard, a convex smooth steel beam, 12" wide, fastened to spring steel supports, which were mounted on either wood or steel posts. In the early 1950's the concept of a metal beam was further refined with the introduction of the W-beam with the two corrugations that are essentially what we are familiar with today.

MICHIGAN DESIGN MANUAL ROAD DESIGN

7.01.03 (continued)

History of Guardrail and Barrier in Michigan

Initially, the W-beam was not galvanized and had to be painted. The next step was to galvanize it for more economical maintenance.

The first installations of W-beam rail involved attaching the beam element directly to posts placed 12'-6" on centers, at a top of rail height of 24". This design later became known as our Beam Guardrail - Type A. Research and crash testing in the late 1950's and early 1960's, principally by the state of California and by General Motors at its Milford Proving Grounds, produced the recommendations of closer post spacing, (6'-3"), blocking out the beam from the post, and a higher top of rail mounting height. This resulted in Michigan's development of our Beam Guardrail - Type C in 1965, and Beam Guardrail - Type B in 1966. A significant change in guardrail type in Michigan occurred in 1984 with the adoption of thrie beam, now called Guardrail, Type T. The most recent change occurred in 2017 with the adoption of the MASH-compliant, non-proprietary, 31" tall w-beam guardrail system with 8" offset blocks, called Guardrail, Type MGS-8.

Until 1995, four basic end treatments had been used in conjunction with steel beam guardrail. Initially, a curved end shoe was placed on both ends of the run. The concept of turning down or burying the ending to form an anchorage was developed about 1966. The first standard plan to be approved by what was then the Federal Bureau of Public Roads was issued in 1968. A variation of the turned down ending, featuring the elimination of the first two posts (so the ending would collapse under impact) appeared in 1971 with the issuance of Standard Plan III-65A.

7.01.03 (continued)

The Breakaway Cable Terminal (BCT) ending was adopted in 1973 with the issuance of Standard Plan III-58A. After 22 years as the standard guardrail terminal in most states, the FHWA disallowed further installation of the BCT on the National Highway System (NHS) after December 31, 1995. This, along with the adoption of new crash testing criteria (NCHRP 350) ended the use of the BCT as well as other traditional un-patented endings.

This initiated the development and use of a number of proprietary terminals. The Department has divided these terminals into two basic categories of flared gating terminals and tangent terminals. Current standard designs are described in [Section 7.01.25](#) along with other designs previously used.

Development of concrete barrier in this country, principally concrete median barrier having the concave safety shape, is generally attributed jointly to General Motors and to the state of New Jersey, both of whom conceived shapes that bear their names. Michigan's first concrete barrier was on the DeQuindre Yard bridge, on I-94 in Detroit, in 1965. Although the New Jersey shape was used in this initial installation, the GM shape was adopted as standard. In 1976 the New Jersey shape became the standard and was used until 2017 when the single slope shape was adopted.

7.01.04

Section deleted

MICHIGAN DESIGN MANUAL ROAD DESIGN

7.01.05 (revised 4-24-2023)

Basic Concepts for Roadside Control

The following are basic concepts and design options for the use or non-use of roadside barriers. The primary sources of information for roadside control are found in the AASHTO documents listed in [Section 7.01.01](#), "References".

- A. A collision with a roadside barrier is considered a crash, because the barrier itself is a roadside obstacle.
- B. A roadside barrier may increase the frequency of crashes, therefore a barrier should only be installed if it will reduce the severity of potential crashes.
- C. When considering the design options for roadside treatment and the progression of design options basic concepts for roadside control should be as follows.
 1. Remove the obstacle or redesign it so it can be safely traversed.
 2. Relocate the obstacle to a point where it is less likely to be struck.
 3. Reduce impact severity by using an appropriate breakaway or traversable device.
 4. Redirect a vehicle by shielding the obstacle with a longitudinal traffic barrier and/or crash cushion.
 5. Delineate the obstacle if the above alternatives are not appropriate.
- D. Generally, a roadside barrier should be placed as far from the traveled way as conditions will permit. See [Section 7.01.30G](#).
- E. Compared to parallel guardrail installations, flared guardrail installations have the advantage of requiring less guardrail to effectively shield a hazard. However, guardrail installations have minimum grading requirements that must be met, and flared guardrail installations may not be economically feasible if extensive earthwork/slope flattening are required.

7.01.05 (continued)

Therefore, the decision to use a flared or parallel guardrail installation should be made on a case-by-case basis taking site-specific conditions into consideration.

- F. To uniformly compute the length of need for roadside barriers, a guardrail worksheet has been developed and should be used on both new and upgrading projects. Computation methods used on this worksheet complies with the guidelines described in the *Roadside Design Guide*. It still remains important that all designers become familiar with the "Guide" to understand the design process. For determining the length of need when non traversable embankments are the only obstacles of concern, see [Section 7.01.30](#).

The worksheet shall be used by all designers, including consulting firms performing work for the Department, to compute guardrail length of needs.

The designer should fill in all data and compute each individual barrier run. This will assure proper compliance to standards and allow each barrier run calculation to be documented and checked for accuracy.

Construction field offices should be sent the completed worksheets for reference during project construction.

The worksheet does not cover all situations which may occur in the field, although it is expected to cover most installations. Any situation not covered by the worksheet shall be similarly documented, along with a sketch providing the details of the guardrail installation.

7.01.06 (revised 2-26-2024)

Guardrail Worksheet

The guardrail worksheet is shown on the following pages.

GUARDRAIL WORKSHEET

(REV. 02-2024)

FOR APPROACH TERMINALS ON R-61-SERIES, R-62-SERIES AND R-63-SERIES

ROUTE _____ CONTROL SECTION _____ JOB # _____

DESIGNED BY _____ DATE _____ CHECKED BY _____ DATE _____

APPROX. STATION OR M.P. _____ DESCRIPTION _____

GUARDRAIL RUN # _____

IF STATIONING IS NOT AVAILABLE, LOCATE TO NEAREST FIXED OBJECT

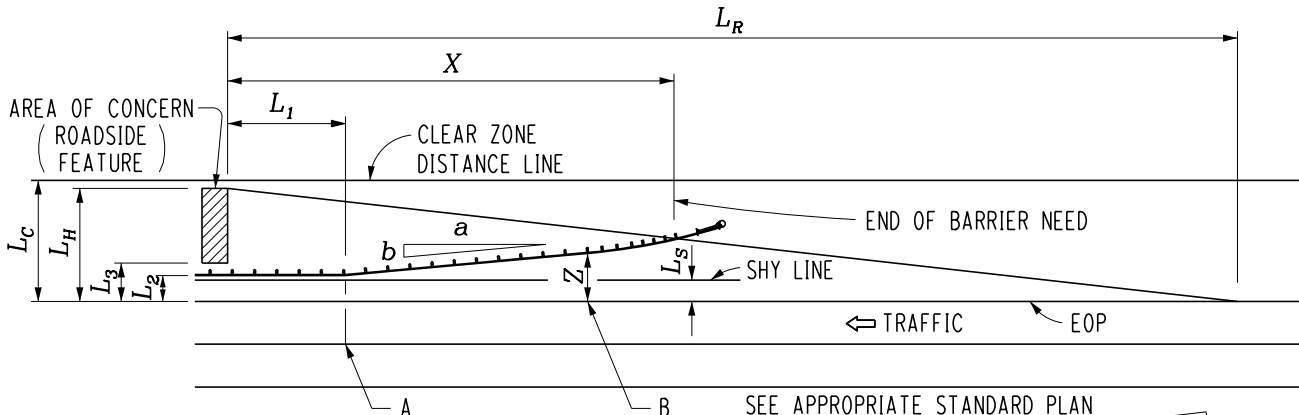

SEE APPROPRIATE STANDARD PLAN FOR GRADING REQUIREMENTS

NOTES: TYPE 1 TERMINAL ILLUSTRATED

$\frac{b}{a}$ (FLARE RATE) = 0 WHEN THE GUARDRAIL RUN IS TANGENT

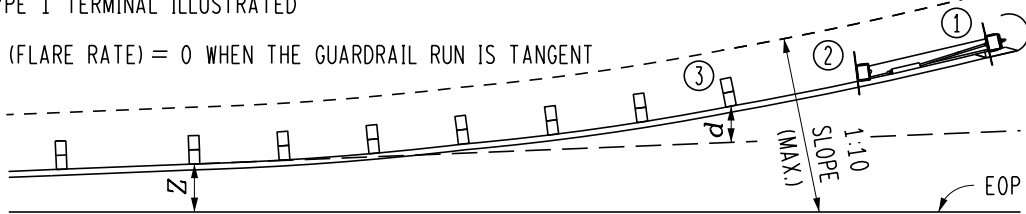

$d = 1.8'$ FOR TYPE 1 TERMINALS
 $d = 0$ FOR TYPE 2 AND 3 TERMINALS

$$X = \frac{L_H + \left(\frac{b}{a}\right)(L_1) - (L_2 + d)}{\frac{b}{a} + \frac{L_H}{L_R}}$$

$$Z = L_2 + (|S_B - S_A|)\left(\frac{b}{a}\right)$$

- LENGTH OF NEED $X =$ _____
- RUNOUT LENGTH (7.01.19) $L_R =$ _____
- GUARDRAIL TAPER RATE (7.01.29A) $\frac{b}{a} =$ _____
- E.O.P. TO FACE OF BARRIER (DESIGNED) $L_2 =$ _____
- CLEAR ZONE (7.01.11) $L_C =$ _____
- E.O.P. TO ROADSIDE FEATURE (MEASURED) $L_3 =$ _____
- EFFECTIVE TURNED OUT DISTANCE OF ANCHORAGE ... $d =$ _____
- LATERAL EXTENT OF ROADSIDE FEATURE (MEASURED). $L_H =$ _____
- LATERAL OFFSET AT END OF FLARE $Z =$ _____

- DESIGN ADT _____
- DESIGN SPEED _____
- APPROACH SLOPE _____
- $L_1 =$ _____ (RECOMMENDED MINIMUM DISTANCE: 25' OR LENGTH OF GUARDRAIL BRIDGE ANCHORAGE MEASURED FROM BRIDGE RAIL ENDING, WHICHEVER IS GREATER)
- $L_S =$ _____ SHY LINE (7.01.18)
- STATION AT A (S_A) _____
- STATION AT B (S_B) _____

NOTE: DISTANCE OF OBJECT FROM BACK OF BARRIER MUST BE GREATER THAN THE MAXIMUM DEFLECTION (7.01.20)

$$L_H \leq L_C$$

REFER TO STANDARD PLAN R-59-SERIES AND DESIGN MANUAL SECTION 7.01.30 FOR GUARDRAIL AT EMBANKMENTS

PROPOSED TREATMENT

CALCULATIONS OR NOTES

PAY ITEMS

- _____ Ft * Guardrail, Type _____, _____ inch Post
- _____ Ea Guardrail Anch, Bridge, Det _____
- _____ Ft Bridge Railing, Thrie Beam Retrofit
- _____ Ea Guardrail Approach Terminal, Type _____
- _____ Ea Guardrail Departing Terminal, Type _____
- _____ Ea Guardrail Reflector
- _____ Cyd Embankment, LM

* FOR THIS PAY ITEM, THE GUARDRAIL APPROACH TERMINAL, TYPE _____ PORTION OF LENGTH OF NEED (X) MUST BE DEDUCTED

DEDUCTION TABLE

GUARDRAIL APPROACH TERMINAL TYPE							
1B	1T	2B	2T	2M	3B	3T	3M
25'	31.25'	37.5'	43.75'	34.3'	12.5'	31.25'	21.8'

PAY LENGTHS MUST BE DIVISIBLE BY 12.5'. ROUND TO NEXT HIGHEST RAIL LENGTH, EXCEPT WHEN TYPE MGS-8 OR TYPE MGS-8D GUARDRAIL IS ATTACHED TO A GUARDRAIL FEATURE REQUIRING A HEIGHT TRANSITION (e.g., GUARDRAIL APPROACH TERMINAL TYPES 1B, 2B, OR 3B; A T-SERIES GUARDRAIL BRIDGE ANCHORAGE; etc.)

ROAD DESIGN MANUAL ROAD DESIGN

7.01.10 (revised 10-21-2013)

Clear Zone – History

For a number of years road designers and safety authorities considered 30' a desirable requirement for a safe roadside free of obstacles. This was based upon a study by General Motors in the early 1960's which revealed that of 211 cases at the proving grounds involving vehicles leaving the road, 80% did not travel more than 29' from the edge of pavement. The 1967 "Yellow Book" (*Highway Design and Operational Practices Related to Highway Safety*, AASHTO), page 20, rounded this distance off to 30'. The 2nd edition of the "Yellow Book", published in 1974, reiterated the 30' distance, but called for an application of engineering judgement by emphasizing that the "30' distance is not a "magic number" (page 38). The 1977 Barrier Guide defined clear zone, in the glossary on page iv, as "That roadside border area, starting at the edge of the traveled way, available for safe use by errant vehicles. Establishment of a minimum width clear zone implies that rigid objects and certain other features with clearances less than the minimum width should be removed, relocated to an inaccessible position outside the minimum clear zone, or remodeled to make safely traversable, breakaway, or shielded."

The 1977 Barrier Guide introduced the concept that rate of sideslope, speed of traffic, horizontal curvature, and ADT would affect the width of clear zone. The 30' width was retained for 60 mph speed in combination with flat side slopes, tangent roadway alignment, and ADT exceeding 6,000. However, a graph on page 16 adjusts this basic 30' for traffic speed and rate of sideslope. These adjustments are both up or down (wider or narrower) for either descending or ascending slope. A formula on page 17 further adjusts the clear zone for horizontal curvature. Finally, a procedure shown on pages 60-65 adjusts the clear zone downward (narrower) for ADT's below 6,000. The Supplement to the 1977 Barrier Guide expanded on the clear

7.01.10 (continued)

zone criteria that begins on page 15 of the Barrier Guide by including a series of tables prepared by the state of Illinois that show clear zone requirements for various degrees of curve. These criteria have been criticized by a number of states because of the extreme clear zone widths, particularly for the combination of sharp curve, higher speed, high traffic volume and steep slope.

In anticipation of a proposed revision of the 1977 Barrier Guide, FHWA in April 1986 afforded the states a measure of relief with respect to clear zone requirements. It provided a formula for a curve correction factor that is based upon increasing the value for clear zone for a tangent section, obtained from the Barrier Guide. This new formula is more reasonable than the formula on page 17 of the Barrier Guide. It was adopted by the Department in July 1986. In 1989 the *Roadside Design Guide* was issued by AASHTO and adopted by MDOT as a guide. Updates to the *Roadside Design Guide* were published in 1996, 2002, 2006 and 2011.

7.01.11 (revised 8-26-2024)

Current Clear Zone Criteria

Virtually everyone agrees that a flat, smooth, unobstructed area adjacent to the driving lanes is highly desirable and significantly improves roadside safety. The only point of contention is how wide to make this area. The designer needs to understand that the clear zone distance is not an absolute number. Some designers have erroneously believed, that in all cases, the need for protecting motorists ends at the selected clear zone distance.

ROAD DESIGN MANUAL ROAD DESIGN

7.01.11 (continued)

Current Clear Zone Criteria

The Department measures the clear zone from the outer edge of the through lane. When determining clear zones in auxiliary lane areas, use the volume of the through lanes and the freeway design speed to obtain the clear zone distance. The resulting clear zone distance should be measured from the outer edge of the through lane and is not to be less than 23 ft out from the outer edge of the auxiliary lane.

The *Roadside Design Guide* defines the clear zone as a variable distance from the traveled way, depending on design speed, ADT, and embankment slope rate and direction.

The Clear Zone Distances Table presents a range of values that can be used for specific conditions. These numbers are based on limited data that was gathered under non-typical conditions and extrapolated to account for sloped roadsides. Also the values obtained from the Clear Zone Distances Table are based on an assumption of constant side slope throughout the clear zone. They must not be perceived as absolute. In situations where the side slope changes within the calculated clear zone, the clear zone may be recalculated based upon a weighted average calculation. An example of this procedure is shown in [Section 13.02.08](#) of this manual.

However, there is no single method for establishing the clear zone, since site conditions must be considered when determining the clear zone at each location. Engineering judgment may need to be exercised when determining the clear zone. Contact the Geometric Design Unit - Design Division if there are any questions pertaining to determining clear zone values.

Application of the values in the Clear Zone Distances Table is dependent on the extent of work and the roadway classification. The higher values should be used on new construction, reconstruction and on all freeways.

7.01.11 (continued)

When evaluating existing conditions and when designing rehabilitation projects, we should attempt to use the higher values; however, economics, existing field conditions, and other restraints may justify using the lower values.

Clear zone for 3R-nonfreeway projects must be selective and generally "fit" conditions within the existing right-of-way and character of the road. Some roadside improvements that should be considered may include removal, relocation, or shielding of such obstacles as culvert headwalls, utility poles, and bridge supports that are within the selective clear zone.

The designer should also be aware that current clear zone distances and 3R guidelines serve as general guidance for Heritage Routes (See [Section 3.09](#)). Narrow pavement, narrow shoulders, winding and/or rolling alignment, steep side slopes, roadside obstacles and narrow right-of-way are common characteristics of Heritage Routes that sometimes prevent the use of even the lower range of the Clear Zone table. Where economic or environmental concerns are great, and there is no history of crash concentration, shorter clear zone distances may be considered to preserve the characteristics of the Heritage Route. Some areas of concern may be addressed with appropriate traffic signing. When distances below the ranges offered in the Clear Zone Distances Table are used, the rationale for the alternative treatment should be noted in the project file.

Tree removal should be considered as stated in [Section 3.09.03C](#). Some alternatives are also offered in the next two sections ([7.01.11A](#) and [7.01.11B](#)).

ROAD DESIGN MANUAL

ROAD DESIGN

7.01.11 (continued)

Current Clear Zone Criteria

A. Treatment/Consideration of Obstacles Outside the Calculated Project Clear Zone

Occasionally, there may be opportunities to improve the roadside safety on a project for a small cost by addressing a few obstacles outside the determined clear zone. Examples of these opportunities are as follows:

1. When installing landscape items: Since we have control over the location of new items, we can provide additional protection to the motorist by applying a more generous clear area to these items. For instance, our freeway guideline for a long time has been to plant trees at least 50 feet off the edge of traffic lanes.
2. When isolated trees, volunteer growth, utility poles, etc. are present: Depending on aesthetic concerns, it may be possible to offer the motorist a very generous clear area (beyond that required by the Clear Zone Distances tables) by simply removing or relocating a few isolated obstacles.
3. Obstacles near the bottom of a ditch are more likely to be hit by an errant vehicle since the ditch tends to funnel the vehicle. Relocating the obstacle further up the back slope, or even slightly up the front slope (closer to road but still outside the clear zone limit), would usually be preferable.
4. A clear runout area beyond the toe of a traversable (smooth and free of fixed objects) but non-recoverable (between 1:4 and 1:3) foreslope is desirable since vehicles traversing this steep slope are likely to continue to the bottom. The extent of this clear runout area can be determined by subtracting the distance between the edge of traveled way and the breakpoint of recoverable foreslope from the clear zone distance. This distance should be at least 10' if feasible.

7.01.11 (continued)

B. Treatment/Consideration of Obstacles Inside the Calculated Project Clear Zone

Where the following conditions exist, it may be necessary to retain trees that otherwise would be considered for removal.

1. At landscaped areas, parks, recreation or residential areas or where the functional and/or aesthetic values will be lost.
2. Exceptional or unique trees (because of their size, species, or historic value).
3. On designated heritage roads and low speed roads (including low speed urban areas).
4. At locations where cumulative loss of trees would result in a significant change in character of the roadside landscape.
5. Behind nontraversable backslopes.
6. Behind vertical curbs, particularly in low speed areas.
7. Where shrubs and/or ornamental trees exist that would have a mature diameter of 4" or less at 4'-6" above ground line.
8. Where removal would adversely affect endangered/threatened species, wetland, water quality, or result in significant erosion/sedimentation problems.

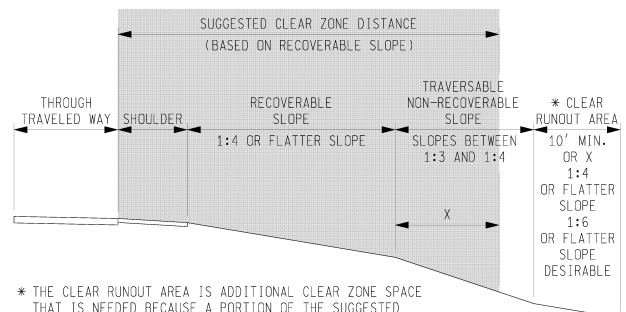

* THE CLEAR RUNOUT AREA IS ADDITIONAL CLEAR ZONE SPACE THAT IS NEEDED BECAUSE A PORTION OF THE SUGGESTED CLEAR ZONE (SHADED AREA) FALLS ON A NON-RECOVERABLE SLOPE. THE WIDTH OF THE CLEAR RUNOUT AREA IS EQUAL TO THAT PORTION OF THE CLEAR ZONE DISTANCE THAT IS LOCATED ON THE NON-RECOVERABLE SLOPE.

ROAD DESIGN MANUAL ROAD DESIGN

7.01.11 (continued)

Current Clear Zone Criteria

C. Clear Zone Distance Chart

**CLEAR ZONE DISTANCES
(IN FEET FROM EDGE OF DRIVING LANE)**

DESIGN SPEED	DESIGN ADT	FILL SLOPES			CUT SLOPES		
		1:6 OR FLATTER	1:5 TO 1:4	1:3	1:3	1:4 TO 1:5	1:6 OR FLATTER
40 mph or Less	under 750	7 - 10	7 - 10	**	7 - 10	7 - 10	7 - 10
	750 - 1500	10 - 12	12 - 14	**	10 - 12	10 - 12	10 - 12
	1500 - 6000	12 - 14	14 - 16	**	12 - 14	12 - 14	12 - 14
	over 6000	14 - 16	16 - 18	**	14 - 16	14 - 16	14 - 16
45-50 mph	under 750	10 - 12	12 - 14	**	8 - 10	8 - 10	10 - 12
	750 - 1500	14 - 16	16 - 20	**	10 - 12	12 - 14	14 - 16
	1500 - 6000	16 - 18	20 - 26	**	12 - 14	14 - 16	16 - 18
	over 6000	20 - 22	24 - 28	**	14 - 16	18 - 20	20 - 22
55 mph	under 750	12 - 14	14 - 18	**	8 - 10	10 - 12	10 - 12
	750 - 1500	16 - 18	20 - 24	**	10 - 12	14 - 16	16 - 18
	1500 - 6000	20 - 22	24 - 30	**	14 - 16	16 - 18	20 - 22
	over 6000	22 - 24	26 - 32*	**	16 - 18	20 - 22	22 - 24
60 mph	under 750	16 - 18	20 - 24	**	10 - 12	12 - 14	14 - 16
	750 - 1500	20 - 24	26 - 32*	**	12 - 14	16 - 18	20 - 22
	1500 - 6000	26 - 30	32 - 40*	**	14 - 18	18 - 22	24 - 26
	over 6000	30 - 32*	36 - 44*	**	20 - 22	24 - 26	26 - 28
≥ 65 mph	under 750	18 - 20	20 - 26	**	10 - 12	14 - 16	14 - 16
	750 - 1500	24 - 26	28 - 36*	**	12 - 16	18 - 20	20 - 22
	1500 - 6000	28 - 32*	34 - 42*	**	16 - 20	22 - 24	26 - 28
	over 6000	30 - 34*	38 - 46*	**	22 - 24	26 - 30	28 - 30

* Where a site-specific investigation indicates a high probability of continuing or higher than expected crashes, or such occurrences are indicated by crash history, the designer may provide clear zone distances greater than 30 feet as indicated. Clear zones may be limited to 30 feet for practicality and to provide a consistent roadway template if previous experience with similar projects or designs indicates satisfactory performance.

** Since recovery is less likely on the unshielded, traversable 1:3 slopes, fixed objects should not be present in the vicinity of the toe of these slopes.

ROAD DESIGN MANUAL ROAD DESIGN

7.01.11 (continued)

Current Clear Zone Criteria

D. Curve Correction Factors Table

The Curve Correction Factors Table shown below shall be applied to horizontal curves with radii less than or equal to 2950 ft. The curve correction factor (Kcz) shall be applied to the outside of curve only. The inside portion of the curve will be treated as a tangent section.

CURVE CORRECTION FACTORS (Kcz) $CZ\ corr = Kcz \times CZ$

Radius (ft)	DESIGN SPEED (mph)						
	40	45	50	55	60	65	70
2950	1.1	1.1	1.1	1.2	1.2	1.2	1.2
2300	1.1	1.1	1.2	1.2	1.2	1.2	1.3
1970	1.1	1.2	1.2	1.2	1.3	1.3	1.4
1640	1.1	1.2	1.2	1.3	1.3	1.3	1.4
1475	1.2	1.2	1.3	1.3	1.4	1.4	1.5
1315	1.2	1.2	1.3	1.3	1.4	1.4	
1150	1.2	1.2	1.3	1.4	1.5	1.5	
985	1.2	1.3	1.4	1.5	1.5	1.5	
820	1.3	1.3	1.4	1.5			
660	1.3	1.4	1.5				
495	1.4	1.5					
330	1.5						

7.01.11 (continued)

E. Other Controlling Factors

For free access highways, the clear zone should ideally be the same as for controlled access highways, but often this is impossible as it would require complete reconstruction of the highway, and destruction of the existing roadside features. Clear zone may often be restricted by drives, intersections, ditches, narrow R.O.W., and other features. While it may be argued that the dynamics of a vehicle running off the road are no different on a free access road than they are on a limited access facility, it remains as a fact of life that there will always be obstacles of some description on free access roads - mailboxes, driveway embankments, trees, buildings, etc. Enormous numbers of these obstacles occur on the trunkline system.

7.01.11 (continued)

Continued efforts should be made to reduce these obstacles as finances permit, even though some cannot be removed without great difficulty, because of socio-environmental considerations, e.g., mature shade trees in a west-facing front yard. However safety considerations should overrule, and if need be, even these mature shade trees may have to be removed.

The designer should note that the presence of an up-slope significantly reduces the clear zone width required. It is therefore seldom necessary to remove a tree or to shield an obstacle that is located at the top of a cut-slope if the elevation of the top of slope is approximately 5'-0" to 6'-0" higher than the edge of pavement. These situations should always be checked, however.

ROAD DESIGN MANUAL ROAD DESIGN

7.01.12 (revised 11-22-2021)

Types of Guardrail Used in Michigan

There are seven standard types of steel beam guardrail in addition to cable barrier found on Michigan highways. The term "Current Use" means "currently proposed for use", not necessarily what may be found existing in the field.

A. Type A (Standard Plan R-60-Series)

Description: W-beam attached directly to posts, Terminal End Shoes on ends. 12'-6" post spacing, 28" height to top of rail.

Current Use:

1. Cul-de-sacs
2. Limited to locations not exposed to through traffic.

B. Type B (Standard Plan R-60-Series)

Description: W-beam guardrail, 8" offset blocks. 6'-3" post spacing, 28" height to top of rail.

Current Use:

1. Updating existing Type B guardrail on free access trunklines when the entire run of guardrail is not being removed and replaced.
2. May be used at the discretion of local agencies on local non-NHS roads.

C. Type BD (Standard Plan R-60-Series)

Description: Type B with W-beam on both sides of the post, 8" offset blocks.

Current Use:

1. Updating existing Type BD guardrail in medians on free access trunklines when the entire run of guardrail is not being removed and replaced.

7.01.12 (continued)

D. Type T (Standard Plan R-60-Series)

Description: Offset three beam rail, 8" offset blocks, 6'-3" post spacing, 34" height to top of rail.

Current Use:

1. Updating existing freeways and ramps when the entire run of guardrail is not being removed and replaced.

E. Type TD (Standard Plan R-60-Series)

Description: Similar to Type T except beam elements and offset blocks are installed on both sides of the post.

Current Use:

1. Used to update existing Type TD guardrail when the entire run of guardrail is not being removed and replaced.

F. Type MGS-8 (Standard Plan R-60-Series)

Description: W-beam guardrail meeting MASH criteria, 8" offset blocks, standard 6'-3" post spacing, and 31" height to top of rail. Beam element splices occur between standard 6'-3" post spaces.

Current Use:

1. Standard MASH-compliant guardrail for all freeways (including ramps) and free access trunklines.
2. All trunkline roads (NHS and non-NHS) and local, NHS roads. Recommended on local, non-NHS roads but not required (per local agency's discretion).

ROAD DESIGN MANUAL ROAD DESIGN

7.01.12 (continued)

Types of Guardrail used in Michigan

G. Type MGS-8D (Standard Plan R-60-Series)

Description: Type MGS-8 with W-beam guardrail and 8" offset blocks on both sides of the post.

Current Use:

1. In all roadway medians, freeway and free access, when median guardrail is recommended and a MASH-compliant guardrail system is desired. On projects let after December 31, 2017, Type MGS guardrail systems will be required for new guardrail installations on all freeways (including ramps) and free access roadways.

H. Cable Barrier (See [Section 7.01.55C](#))

Description: Three or four steel cables mounted on steel posts, anchored and tensioned.

Current Use:

1. Medians where crash history indicates cross median crashes and rigid barrier is not warranted.
2. Special situations where up to 90 degree impacts can be expected and larger deflections can be tolerated.

7.01.13 (revised 4-24-2023)

Curved Beam Elements

Curved steel beam elements having a radius of 150' or less must be shop bent. W-beam and thrie-beam guardrail can be shop bent. However, thrie-beam transition panels, both symmetrical and asymmetrical, cannot be shop bent. Shop bent guardrail beam elements can be curved concave (inward) or convex (outward) as required. The radius for curved guardrail beam elements should be reported in increments of 5 feet. The smallest radius for curved guardrail is 5 feet, although guardrail with very small radii should only be used when necessary. Designers should try to be as accurate as possible when specifying a radius for curved rail, as it is time consuming and expensive returning elements to the shop for re-bending. When shop bent rail will be required, the following note should be included on the plans: "Shop bent curved guardrail elements shall not be ordered until the radius has been field verified by the Engineer."

ROAD DESIGN MANUAL ROAD DESIGN

7.01.14 (revised 12-22-2011)

Guardrail Surface Finish

A. Galvanized

For a short time in the early to mid-1950's, the first steel W-beam guardrail was not galvanized and therefore had to be painted. Subsequently, galvanized beam elements were supplied and have been used ever since except, of course, for the use of weathering steel. The galvanizing coating is considered to have a service life of at least 25 years under average conditions before exhibiting significant rusting. Some of the earlier accepted galvanized rails were "pre-galvanized" and had very thin zinc coatings. These have rusted at a considerably premature age. From that time, a heavier galvanizing was applied by hot dip method after forming. This exhibited good durability. The industry asked for reconsideration of the pre-galvanized method in 1995. The Construction Field Services Division performed a study to determine the weather resistance of pre-galvanized rail. The results of an accelerated weathering simulation were acceptable. The specifications now allow for either method of galvanizing.

7.01.14 (continued)

B. Unpainted Corrosion-Resistant

Atmospheric corrosion resistant guardrail (sometimes referred to as "weathering" or "rusty steel" guardrail) was first installed in Michigan, at 3 test sites, in 1963. It was adopted as standard by the Department in late 1971. If galvanized beam was desired, and it was in certain locations where visibility was especially needed, then it had to be specified on the plans and in the pay item. The theory behind the development of this material was that, being uncoated, it would oxidize rather quickly to a uniform brown color, the chemistry of the steel causing the surface rust to be dense and adherent. After the initial surface rust had formed, it was thought that further oxidation would proceed very slowly as the oxides would form a protective coating, making painting unnecessary. Initially, the buffered endings were galvanized, but in 1976 it was decided to specify corrosion resistant steel for them as well. In early 1980 a moratorium was placed on the use of weathering steel, requiring all new guardrail be galvanized according to the former requirements. The moratorium was prompted by the discovery that, when chloride contamination occurred, oxidation of the metal did not slow up after the initial rusting, and crevice corrosion accelerated the attack on the overlapped surfaces. Concerns were expressed that the useful life of the rail would be considerably less than that originally anticipated. The moratorium led to a permanent discontinuation of the use of weathering steel.

ROAD DESIGN MANUAL ROAD DESIGN

7.01.14 (continued)

Guardrail Surface Finish

C. Corrosion-Resistant Guardrail Replacement Policy

The Engineering Operations Committee, meeting on January 20, 1989, decided that all existing corrosion resistant, or "rusty steel", guardrail encountered on proposed Interstate resurfacing or reconstruction projects should be removed and replaced as part of the project. On projects involving bridges only, the nominal provisions of the approach guardrail anchorage shall be replaced if the rail elements are rusty steel. Where guardrail at the bridge approaches is part of a more extensive installation, the decision to replace will be made on the merits of the specific project. See [Section 7.01.44](#) for upgrading local roads.

7.01.15 (revised 9-28-2020)

Guardrail Terminals

Use the identified guardrail terminal types as indicated below.

A. Guardrail Departing Terminal, MGS (Standard Plan R-66-Series)

Current Use:

1. Departing end of Guardrail, Type MGS-8, on one-way roadways.
2. Departing end of Guardrail, Type MGS-8, on two-way roadways when located outside the clear zone.

B. Guardrail Approach Terminal, Type 2M (Standard Plan R-62-Series)

Current Use:

1. On one or both ends of Guardrail, Type MGS-8 located within the clear zone of approaching traffic.
2. May also be used on one or both ends of Guardrail, Type T or Guardrail, Type B with an appropriate transition section (refer to Standard Plan R-60-Series).

ROAD DESIGN MANUAL ROAD DESIGN

7.01.15 (continued)

C. Guardrail Departing Terminal, Type B (Standard Plan R-66-Series)

Current Use:

As recommended by the Geometric Design Unit where Guardrail Departing Terminal, Type MGS is not practicable for the departing end of Guardrail Type B on;

1. one-way roadways.
2. two-way roadways when located outside the clear zone.
3. other applications as recommended by the Geometric Design Unit.

D. Guardrail Departing Terminal, Type T (Standard Plan R-66-Series)

Current Use:

As recommended by the Geometric Design Unit where Guardrail Departing Terminal, Type MGS is not practicable for the departing end of Guardrail Type T on;

1. one-way roadways.
2. two-way roadways when located outside the clear zone.
3. other applications as recommended by the Geometric Design Unit.

7.01.15 (continued)

E. Guardrail Approach Terminal, Type 1B (Request Special Details from the Design Standards Unit)

Current Use:

As recommended by the Geometric Design Unit for use in special cases where a Type 2M guardrail approach terminal is not practicable, and a Type 1 (flared) guardrail approach terminal is necessary on;

1. one or both ends of Guardrail, Type B and Guardrail, Type MGS-8 located within the clear zone of approaching traffic.

F. Guardrail Approach Terminal, Type 1T (Request Special Details from the Design Standards Unit)

Current Use:

As recommended by the Geometric Design Unit for use in special cases where a Type 2M guardrail approach terminal is not practicable, and a Type 1 (flared) guardrail approach terminal is necessary on;

1. one or both ends of Guardrail, Type T located within the clear zone of approaching traffic

ROAD DESIGN MANUAL

ROAD DESIGN

7.01.16 (revised 4-24-2023)

Guardrail Attachment to Bridges and Walls

The following guardrail anchorage details are in current use for new construction and where specified for upgrading and are detailed on Standard Plans R-67-Series, B-22-Series, B-23-Series:

A. Guardrail Anchorage, Bridge, Details M1 & M4 (See Standard Plan R-67-Series)

Current Use:

When connecting Guardrail, Type MGS-8 to Bridge Railing, 2-Tube, 4-Tube, Aesthetic Parapet Tube, 3 Tube with Pickets, Concrete Block Retrofit, Type 6, Type 7, or Single Face Concrete Barrier without expansion at backwall (M1) or with expansion at backwall (M4).

B. Guardrail Anchorage, Bridge, Details M2 & M5 (See Standard Plan R-67-Series)

Current Use:

When connecting Guardrail, Type T to Bridge Railing, 2-Tube, 4-Tube, Aesthetic Parapet Tube, 3 Tube with Pickets, Concrete Block Retrofit, Type 6, Type 7, or Single Face Concrete Barrier without expansion at backwall (M2) or with expansion at backwall (M5).

C. Guardrail Anchorage, Bridge, Details M3 & M6 (See Standard Plan R-67-Series)

Current Use:

When connecting Guardrail, Type B to Bridge Railing, 2-Tube, 4-Tube, Aesthetic Parapet Tube, 3 Tube with Pickets, Concrete Block Retrofit, Type 6, Type 7, or Single Face Concrete Barrier without expansion at backwall (M3) or with expansion at backwall (M6).

7.01.16 (continued)

D. Guardrail Anchorage, Bridge, Details M7, M8 & M9 (See Standard Plan R-67-Series)

Current Use:

When connecting Guardrail, Type MGS-8 (M7), Type T (M8) or Type B (M9) to Filler Wall.

E. Guardrail Anchorage, Bridge, Detail A3 (See Standard Plans B-22-Series and B-23-Series)

Current Use:

When connecting Guardrail, Type MGS-8 to Bridge Railing, Thrie Beam Retrofit.

F. Guardrail Anchorage, Bridge, Detail A4 (See Standard Plans B-22-Series and B-23-Series)

Current Use:

When connecting Guardrail, Type T to Bridge Railing, Thrie Beam Retrofit.

G. Guardrail Anchorage, Bridge, Detail A5 (See Standard Plans B-22-Series and B-23-Series)

Current Use:

When connecting Guardrail, Type B to Bridge Railing, Thrie Beam Retrofit.

H. Need for Additional Expansion

The Guardrail Anchorage, Bridge details on Standard Plan R-67-Series will accommodate thermal deck movement up to about 4". If the expected thermal deck movement will exceed 4", the Road designer should consult with the Bridge designer to decide the method for providing the additional expansion required in the guardrail.

ROAD DESIGN MANUAL

ROAD DESIGN

7.01.16 (continued)

Guardrail Attachment to Bridges and Walls

I. Curved Guardrail Bridge Anchorages

While not desirable, in some cases it may be necessary to curve a guardrail bridge anchorage. This is commonly the case when there is an intersecting driveway or street located near a bridge, and the intersecting driveway or street cannot be closed or relocated. It is acceptable to curve only a portion of the guardrail anchorage.

If guardrail panels must be curved to a radius of 150' or less, use the Guardrail Anch Bridge, Det __, Curved pay item. Also, note that three-beam transition panels, both symmetrical and asymmetrical, cannot be shop bent. So designers need to select guardrail anchorage details that do not have three-beam transition panels within the curved section when dealing with radii of 150 feet or less.

ROAD DESIGN MANUAL ROAD DESIGN

7.01.17 (revised 4-24-2023)

Strength Requirements of Steel Beam Guardrail

The Standard Specifications reference material requirements for steel beam guardrail and associated hardware to AASHTO Specification M 180, which requires 70,000 psi tensile strength in the base metal.

Crash testing of roadside safety devices, such as guardrail and other barriers, is standardized according to procedures outlined in *National Cooperative Highway Research Program Report 350* (NCHRP 350) and the *Manual for Assessing Safety Hardware* (MASH), respectively.

MASH contains the current guidelines for testing and evaluating roadside safety devices, thereby superseding NCHRP 350. As of January 1, 2011, newly tested or modified roadside safety devices must be evaluated using MASH criteria.

7.01.17 (continued)

There are up to six test levels in NCHRP 350 and MASH, respectively, depending on the feature being evaluated. All six test levels apply to longitudinal barriers. Test levels 2 and 3 apply to breakaway features and test levels 1, 2, and 3 apply to crash cushions and end treatments.

Fundamentally, guardrail is intended to redirect the impacting vehicle, not stop it. Energy absorption and vehicle deceleration are the functions of an impact attenuator (or a Type 2 terminal, under certain conditions). For this reason, 25 degrees is the maximum angle used in testing for guardrail strength.

The designer will occasionally encounter situations where a broad area must be shielded. These may be areas wide enough to allow a vehicle to exceed 25 degrees in approach angle and too wide to make an impact attenuator feasible. These situations must be studied. The solution will usually involve guardrail placed in a curving configuration or the use of cable barrier if there is room for the deflection that is characteristic of a cable barrier.

NCHRP 350 Test Level	Vehicle	Impact Conditions	
		Nominal Speed (km/h)	Nominal Angle (deg)
1	2000P (2000 kg pick up truck)	50	25
2	2000P (2000 kg pick up truck)	70	25
3	2000P (2000 kg pick up truck)	100	25
4	8000S (8000 kg single unit truck)	80	15
5	3600V (3600 kg tractor van trailer)	80	15
6	3600T (3600 kg tractor tanker-type trailer)	80	15

ROAD DESIGN MANUAL ROAD DESIGN

7.01.17 (continued)

Strength Requirements of Steel Beam Guardrail

MASH Test Level	Test Vehicle Designation and Type	Impact Conditions		
		Vehicle Weight Kg (lbs)	Speed km/h (mph)	Angle Degrees
1	1,100C (Passenger Car)	1,100 (2,420)	50 (31)	25
	2,270P (Pickup Truck)	2,270 (5,000)	50 (31)	25
2	1,100C (Passenger Car)	1,100 (2,420)	70 (44)	25
	2,270P (Pickup Truck)	2,270 (5,000)	70 (44)	25
3	1,100C (Passenger Car)	1,100 (2,420)	100 (62)	25
	2,270P (Pickup Truck)	2,270 (5,000)	100 (62)	25
4	1,100C (Passenger Car)	1,100 (2,420)	100 (62)	25
	2,270P (Pickup Truck)	2,270 (5,000)	100 (62)	25
	10,000S (Single Unit Truck)	10,000 (22,000)	90 (56)	15
5	1,100C (Passenger Car)	1,100 (2,420)	100 (62)	25
	2,270P (Pickup Truck)	2,270 (5,000)	100 (62)	25
	36,000V (Tractor-Van Trailer)	36,000 (79,300)	80 (50)	15
6	1,100C (Passenger Car)	1,100 (2,420)	100 (62)	25
	2,270P (Pickup Truck)	2,270 (5,000)	100 (62)	25
	36,000T (Tractor-Tank Trailer)	36,000 (79,300)	80 (50)	15

7.01.18 (revised 10-21-2013)

Suggested Shy Line Offset Values

Shy line offset is the distance from the edge of traveled way in which a roadside object will not be perceived as an obstacle or result in the driver reducing speed or changing the vehicle's path of travel.

Design Speed (mph)	Shy Line Offset (L_s) (ft)
80	12
75	10
70	9
60	8
55	7
50	6.5
45	6
40	5
30	4

ROAD DESIGN MANUAL ROAD DESIGN

7.01.19 (revised 6-28-2021)

Suggested Runout Lengths for Barrier Design

Runout length is the distance from the object being shielded to the point the vehicle is assumed to depart from the roadway. Interpolation between runout length values is recommended when dealing with intermediate design speeds.

	Traffic Volume (ADT) veh/day			
	Over 10,000	Over 5,000-10,000	1000-5000	Under 1000
Design Speed (mph)	Runout Length L _R (ft)	Runout Length L _R (ft)	Runout Length L _R (ft)	Runout Length L _R (ft)
80	470	430	380	330
70	360	330	290	250
60	300	250	210	200
50	230	190	160	150
40	160	130	110	100
30	110	90	80	70

7.01.20 (revised 4-24-2023)

Guardrail Deflection

Both steel beam guardrail and cable barriers are expected to deflect under impact. This deflection is a result of deformation of the beam element or stretching of the steel cable, fracturing of the post (if wood) or bending of the post (if steel), and lateral displacement of the post in the soil. It is therefore necessary that room for deflection be provided between the back of the rail system (e.g. back of posts) and the object or area being shielded. For design purposes, use the chart at the end of this section for the recommended minimum design offset distances of the various guardrail systems. Refer to [Section 7.01.55C](#), "Cable Barrier", for expected deflections and offset recommends of cable barrier systems.

7.01.20 (continued)

It should be noted that the recommended offset distances should not be treated as absolute values, since guardrail deflection may vary for different impact conditions, soil types and moisture contents, thawed or frozen ground, different types of posts, different types of anchorages, and differing lengths of installation. Therefore, the recommended offset distances should be treated as minimums, and larger offset distances between the back of the rail system (e.g., back of posts) and the object or area being shielded should be provided where feasible. In general and, where feasible, the offset should be increased by 12 inches or more beyond the recommended minimum value. If specific site conditions are such that it is predictable that greater deflection values may occur, and space for deflection is restricted, then shorter post spacing should be considered. Shorter post spacing is only effective, however, if the full effect of proper post embedment is realized. See [Section 7.01.41D](#), "Guardrail Posts at or near the Shoulder Hinge Line". See also Section 5.5.2, 2011 AASHTO Roadside Design Guide.

ROAD DESIGN MANUAL ROAD DESIGN

7.01.20 (continued)

Guardrail Deflection

Guardrail	Post Spacing	Minimum Design Offset *
Type T	1'-6 ³ / ₄ "	1'-2"
Type T	3'-1 ¹ / ₂ "	1'-8"
Type T	6'-3"	2'-0"
Type B	1'-6 ³ / ₄ "	1'-6"
Type B	3'-1 ¹ / ₂ "	2'-0"
Type B	6'-3"	3'-0"
Type MGS-8	1'-6 ³ / ₄ "	2'-5"
Type MGS-8	3'-1 ¹ / ₂ "	2'-11"
Type MGS-8	6'-3"	3'-6"
Type MGS-8 Adjacent to Curb	6'-3"	4'-1"
Type MGS-8 Near Shoulder Hinge Point **	6'-3"	4'-1"

* An additional 12" or more is desirable where feasible

** Less than 2'-8" from the shoulder hinge point to the face of guardrail post

The Zone of Intrusion (ZOI) is the region measured above and behind the face of a barrier system where an impacting vehicle or any major part of the system may extend during an impact. For a typical TL-3 system, the ZOI extends between 18" and 30" behind the traffic side face of the barrier. Where practical, the designer should keep objects out of this area. See Section 5.5.2, 2011 AASHTO Roadside Design Guide, for additional ZOI guidance.

ROAD DESIGN MANUAL ROAD DESIGN

7.01.21 (revised 10-21-2013)

Guardrail Strength Transitions

Sudden and significant changes in lateral stiffness of a barrier system may cause an impacting vehicle to pocket, if it proceeds from a weaker system to a stronger system. A gradual modification of the deflection characteristics of the barrier is therefore needed. This may be achieved by closer post spacing, heavier barrier elements, larger posts or a combination of these. Illustrated below is

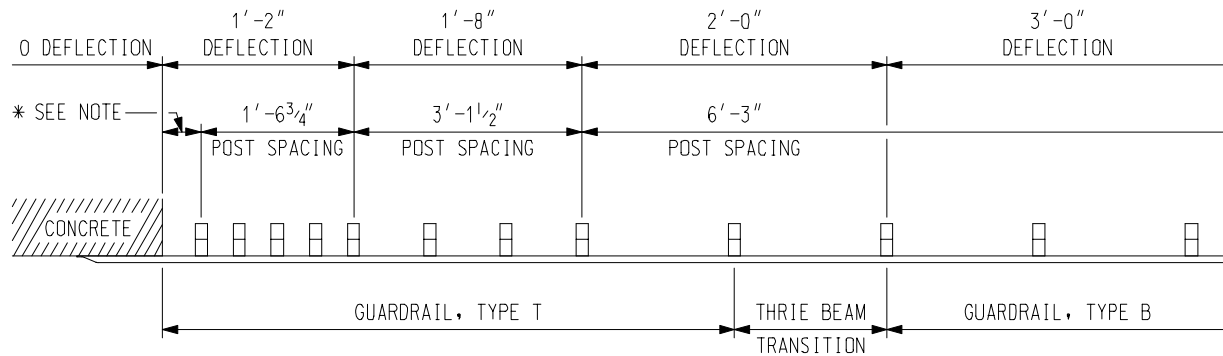

* NOTE: 15" WHEN SPECIAL END SHOE HAS $\frac{29}{32}$ " x 5" SLOTS
16" WHEN SPECIAL END SHOE HAS $\frac{29}{32}$ " x 3" SLOTS

7.01.21 (continued)

a typical transition from Guardrail, Type B to a concrete barrier, filler wall, or barrier railing. The 2011 AASHTO, *Roadside Design Guide* (page 7-15) advocates that the transition length between joining barrier types should be approximately 10 to 12 times the difference in dynamic deflection. For a difference in deflection of 12", the transition stiffening length should occur in one effective beam element length or 12'-6". See [Section 7.01.20](#) for dynamic deflections.

7.01.22 (10-22-99)

Minimum Guardrail Lengths and Gaps

A free-standing section of guardrail (one not attached to a bridge or other structure) should be at least 100' in length. Greater lengths are recommended; lesser lengths may be acceptable under low speed conditions. A gap of less than approximately 200' between barrier installations should be avoided. Usually this will require filling in the gap with connecting barrier. An exception would be the unique situation where an approach and trailing ending, separated by a gap, can be buried in a cut slope, and the consequences of a vehicle encroaching on the cut slope would be less than hitting the guardrail filling the gap.

7.01.23 (revised 4-24-2023)

Function of Guardrail Components

It is essential that the designer understand the function of the various components of a guardrail system and some of the principles underlying barrier design details.

Beam height – The top of rail height is essential for proper barrier performance (28" for Type B, 31" for Type MGS-8, and 34" for Type T).

ROAD DESIGN MANUAL ROAD DESIGN

7.01.23 (continued)

Function of Guardrail Components

Offset block - Serves two principal purposes, 1) locates beam farther from the post to minimize the possibility of wheel snagging on the post and pocketing in the guardrail, and 2) maintains top of rail height momentarily longer as the post rotates backward under impact, reducing the probability of the vehicle vaulting over the rail. (See page 5-16, 2011 AASHTO, *Roadside Design Guide*)

Round washer - Provides an even bearing surface around holes that are often field-drilled and rough.

Post bolt washer - Used in earlier guardrail systems to prevent the head of the post bolt from pulling through the beam element. However, it was later determined that allowing the post bolt head to pull through the beam element during a crash was better from a guardrail performance standpoint. Therefore, all current guardrail types used by MDOT do not call for the use of post bolt washers. Washers are now recommended only on the end post of the SRT, or on the end post in a Departing End Terminal.

Rail splice - Splices, of course, are unavoidable. They should be at least as strong as the rail itself; all eight connection bolts (twelve in thrie beam) are needed to distribute the load throughout the rail section. Lapped splices are usually such that the outer rail overlaps in the downstream direction, to reduce the potential of vehicle snagging.

7.01.24

Accommodation of Expansion

Provision must be made for the movement of guardrail beam elements caused by thermal expansion and contraction. The movement in rail elements is accomplished by means of oblong slots at the splices. Additional expansion at structures is obtained by means of longer slots in the Special End Shoes and Thrie Beam Expansion Section illustrated on Standard Plan R-67-Series (see [Section 7.01.16l](#)).

ROAD DESIGN MANUAL

ROAD DESIGN

7.01.25 (revised 4-24-2023)

Guardrail Approach Terminals

Crashworthy end treatments are critical to guardrail installations. An approach terminal is designed to redirect an impacting vehicle and to reduce the occurrences of a vehicle being penetrated, rolled, or vaulted in an end on hit. The following section describes the characteristics and uses of approved standard treatments.

A. Type 1 Terminals

Type 1 guardrail approach terminals are flared gating terminals used only in special cases at locations where a Type 2M guardrail approach is not feasible, and a Type 1 guardrail approach terminal is necessary. This is the design formerly preferred when grading limits allow for the appropriate 4'-0" offset of the terminal end from the tangent extension of the standard line of guardrail run. When the Type 1 terminal is called for on the plans by special detail, the contractor may use one of the approved terminal options. The special detail is available by request from the Design Standards Unit.

Consult with the Geometrics Design Unit, Design Division, when considering use of a Type 1 guardrail approach terminal.

7.01.25 (continued)

B. Type 2 Terminals

Type 2 terminals are tangent, energy absorbing terminals which require less grading than the Type 1 terminals. There is currently only one subcategory under the Type 2 terminal category; Type 2M.

1. Type 2M Terminals

Type 2M terminals are MASH-compliant tangent guardrail approach terminals. They are specified in Standard Plan R-62-Series and by special provision. Type 2M terminals are required for new installations and when updating guardrail approach terminals, except in special cases. These terminals are intended to be attached directly to Type MGS-8 guardrail. Therefore, designers will need to include an appropriate transition section for connecting a Type 2M guardrail terminal to either Type B or Type T guardrail (refer to Standard Plan R-60-Series). Current Type 2M terminals available for use are the MSKT, the Soft-Stop, and the MAX-Tension. Refer to Standard Plan R-62-Series for the overall length, recommended offset, and grading requirements of each terminal.

Contact the Geometrics Design Unit, Design Division, for additional information regarding MASH-compliant guardrail terminals.

2. Minimum Offset

The original intent of the Type 2 terminals was to provide endings that required no offset. This was the orientation used in the crash tested system. However, all three approved Type 2M approach terminals (MSKT, Soft-Stop, and Max-Tension) may be installed with an offset between 0 and 2 feet. A 1'-0" offset was adopted in Standard Plan R-62-Series in order to minimize the number of nuisance accidents that may occur when the impact head was located close to or encroaching on the shoulder.

ROAD DESIGN MANUAL ROAD DESIGN

7.01.25 (continued)

Guardrail Approach Terminals

C. Function of the Various Guardrail Terminal Components

It is important that designers, as well as construction and maintenance personnel, understand the function of the components that make up guardrail terminals.

Please note that guardrail terminals are comprised of a wide variety of different components, and each guardrail terminal has its own set of unique parts and assembly requirements. Therefore, the following is not intended to be a comprehensive list of all guardrail terminal components. Contact the Geometric Design Unit - Design Division if there are any questions related to guardrail terminal components and their function.

Bearing plate - Distributes the forces in the cable to the post.

Terminal End Shoe - This feature absorbs some of the impact forces, spreading them over a wider area, to reduce the potential for the end of the beam element to penetrate the vehicle passenger compartment. This feature is found on guardrail departing terminals and certain guardrail approach terminals, such as the SRT and BCT.

Impact head - The impact head, like a terminal end shoe, helps spread the forces over a wider area. Some impact heads are designed to extrude or compress the guardrail as the head gets pushed along the guardrail by an impacting vehicle, thereby absorbing energy from the impact. With some terminals, the rail element passes through the impact head and is extruded away from the impacting vehicle.

The physics and overall function of each terminal, including the function of the impact head, varies by terminal brand.

7.01.25 (continued)

Cable Assembly - For downstream impacts, transfers tensile forces from the beam to the base of the end post, allowing the full redirective strength of the rail system to be developed at the third post. For ending impacts the cable is released and serves no purpose. However, not all terminals utilize cable assemblies. For example, the Soft-Stop does not require a cable assembly, since the guardrail end is bolted to a post in a manner allowing all tensile forces in the guardrail to be transferred to the post.

Channel or Angle Strut - This strut and yoke distributes the load from the tensioned cable between the first and second post. The strut also contributes to the collapse of the second post during an end on impact. Please note, not all terminals utilize a channel or angle strut.

Controlled release terminal (CRT) post - CRT posts are 6" x 8" wood posts with two 3½" diameter holes drilled through the post. One hole is placed at the ground line and the other 1'-4" below the ground, to facilitate fracture of the post during end-on impacts.

Holes in the two end posts - These holes are used to weaken the end posts and to allow them to break off close to the ground, when the guardrail ending is struck by an end impacting vehicle. The guardrail ending will likely collapse, thereby reducing spearing and vaulting. The holes have no function for downstream impacts.

Pipe Insert - No function for ending impacts. For downstream impacts, distributes vertical component of forces in the cable to the post.

ROAD DESIGN MANUAL ROAD DESIGN

7.01.25 (continued)

Guardrail Approach Terminals

Slotted Rail Element (SRT) - The first two panels of rail in the SRT are slotted to provide controlled dynamic buckling. Rail buckling in the SRT is controlled by the length and location of the slots. The controlled buckling of the rail element reduces the potential for the rail to directly impact or penetrate the vehicle occupant compartment.

Slot guard (SRT) - Slot guards are installed on the SRT at the downstream end of each set of rail slots. It prevents the bumper or other parts of the impacting vehicle from intruding into and extending the slots.

Soil plate - Inhibits movement of the post in the soil; aids in keeping the post from pulling out of the ground.

Steel sleeves - For ending impacts, reduces tendency for the post to rotate in the soil; aids in resisting movement so the post will break off at the weakening hole. For downstream impacts, distributes loads from the post to the soil.

D. Guardrail Full Strength Point

When a standard guardrail terminal is used, the length of need is calculated to a point where the guardrail run develops the full strength of the system. This is typically known as the beginning length of need (BLON) point. It should be stressed that most guardrail approach terminals are gating terminals, meaning the BLON point is located beyond the nose of the terminal. Designers need to take this into consideration when performing length of need calculations. The deduction values in the MDOT guardrail worksheet have taken the BLON points into consideration.

7.01.25 (continued)

E. Clear Area Behind Guardrail Terminals

When determining the length of need of a guardrail run, the designer should verify that there will be no obstacle behind or to the behind side of a guardrail terminal that would prevent gating.

The area behind should be traversable for the vehicle after it passes through the terminal. The minimum recovery area behind and beyond a terminal should be an obstacle free area approximately 75' long and 20' wide. If it appears that the area behind will not be traversable, then the guardrail run will probably have to be extended to a point where the area behind the terminal is clear.

F. Burying Ending in a Backslope

Occasionally high cut slopes adjacent to the traveled roadway do not provide sufficient clear area behind the terminal to allow gating, or adequate site conditions may exist making a buried-in-backslope terminal desirable.

In these cases, the designer should consider terminating the guardrail inside the backslope. The designer or project manager can obtain a special detail for this treatment from the Design Standards Unit.

G. Slope Under Guardrail Terminals

The area under the terminal should be graded to a 1:10 slope or flatter from the edge of the traveled lane and extend at least 2'-0" behind the back of posts. In addition, the terminal details include required grading in advance of the terminal approach. The designer should consider these required limits when estimating grading and earthwork quantities. See the appropriate guardrail approach terminal Standard Plans for grading details.

ROAD DESIGN MANUAL

ROAD DESIGN

7.01.29 (revised 4-24-2023)

Guardrail Flare

When designing guardrail, the designer should take advantage of opportunities to flare the installation. This reduces the required length of need. It also places the guardrail terminal farther from the traveled lane, thus reducing the potential for nuisance hits.

A. Flare Rate

The maximum recommended flare rate is dependent on barrier type and design speed. Maximum flare rates are provided to minimize impact severity, since a barrier flared toward traffic in the downstream direction will result in a larger impact angle between the impacting vehicle and the barrier, and this will increase the impact severity. Consequently, the maximum flare rates for rigid barriers, such as concrete barriers, are typically less than those for semi-rigid barriers, such as guardrail.

The specified flare rates are maximums, and shallower (flatter) flare rates may be used.

Larger flare rates may be considered in certain cases, such as barrier sections flared away from traffic in the downstream direction, where the resulting angle between an impact vehicle and the barrier would be less than expected compared to a non-flared barrier installation.

Design Speed (mph)	Flare Rate (b/a) for	
	Concrete Barriers	Guardrail
70	1:20	1:15
60	1:18	1:14
55	1:16	1:12
50	1:14	1:11
45	1:12	1:10
40	1:10	1:8
30	1:8	1:7

ROAD DESIGN MANUAL

ROAD DESIGN

7.01.29 (continued)

Guardrail Flare

B. Uniform Flare from Structures

Guardrail may need to be flared inward to meet the bridge barrier railing of bridges with narrow shoulders. When the guardrail length at a structure is increased, such as for an embankment, a uniform guardrail flare rate (not flatter than 1:30) may be substituted for the combined short parallel section and the two flared sections. The illustration at right shows this situation on a left approach rail. When the shielded area in advance of the bridge rail is a steep embankment, the length of need is determined as outlined in [Section 7.01.30E](#). A uniform flare can then be constructed between the guardrail anchorage and the guardrail approach terminal.

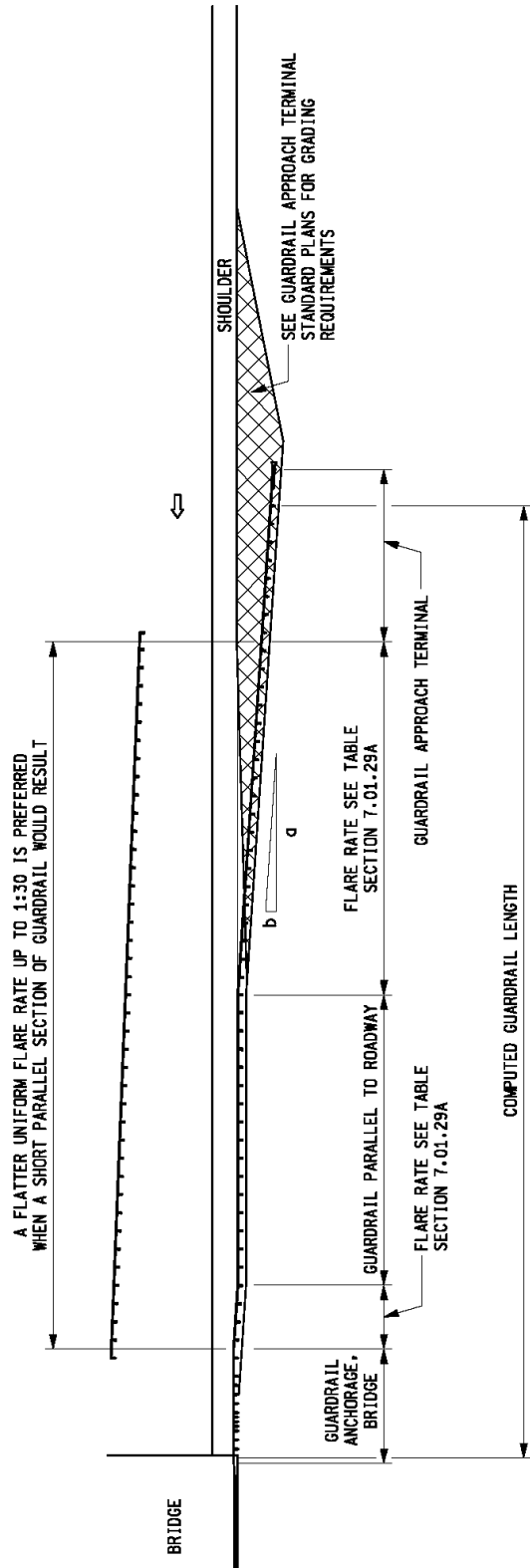

ROAD DESIGN MANUAL ROAD DESIGN

7.01.30 (revised 4-24-2023)

Guardrail at Embankments

As a general rule, a barrier should be placed to protect a vehicle from going down an embankment only if the barrier itself is the least severe of the two features. Such a comparison must of necessity be very subjective because of the many variables involved. The Department generally follows the criterion that, if the fill slope is 1:3 or flatter, no barrier is required. For slopes of 1:3 or flatter, the height of fill does not increase severity.

7.01.30 (continued)

The economics of earthwork obviously dictate that all slopes cannot be 1:6, regardless of fill height. As the fill becomes higher, more consideration must be given to steepening the slopes, which in turn may call for a decision relative to placing a barrier.

Slopes intended to be traversable, i.e., one flat enough that a barrier can be omitted but still perhaps 1:3, should be relatively free of discontinuities that might "trip up" a vehicle. Plans should note that half-buried boulders and large rocks should be removed as part of the final trimming operation. Also, a clear runout area with a 10' minimum width should be provided at the bottom of traversable, non-recoverable slopes.

A. Height-Slope Guidelines

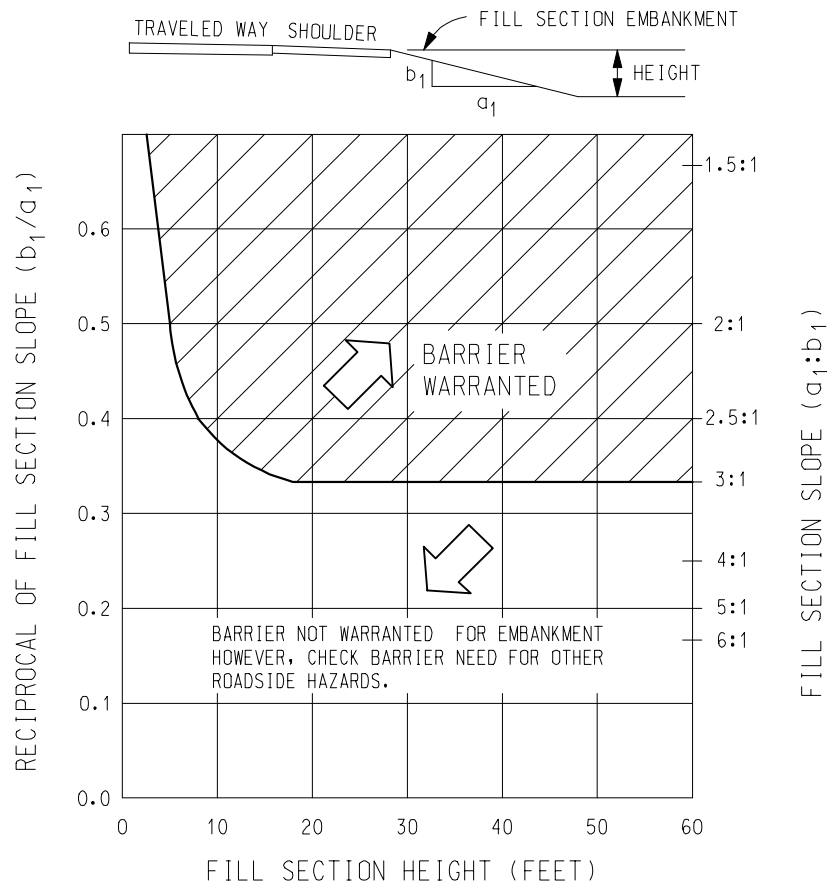

ROAD DESIGN MANUAL

ROAD DESIGN

7.01.30 (continued)

Guardrail at Embankments

B. Location on Fill Sections (New Construction)

The following shoulder sections with guardrail are shown to clarify and standardize the location of guardrail. Divided highway sections illustrate guardrail on left and right shoulders of each roadway.

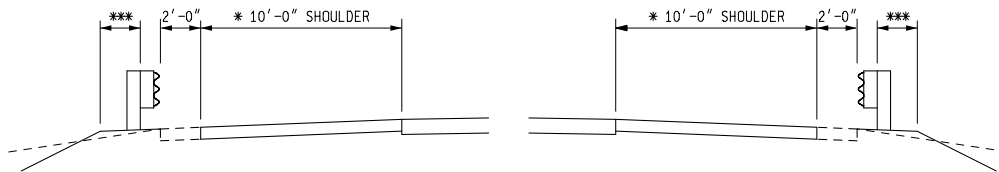

DIVIDED, 3 OR MORE LANES IN ONE DIRECTION

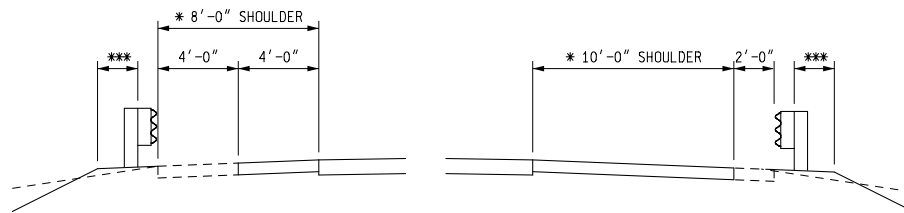

DIVIDED, 2 LANES IN ONE DIRECTION AND 2 LANE RAMPS

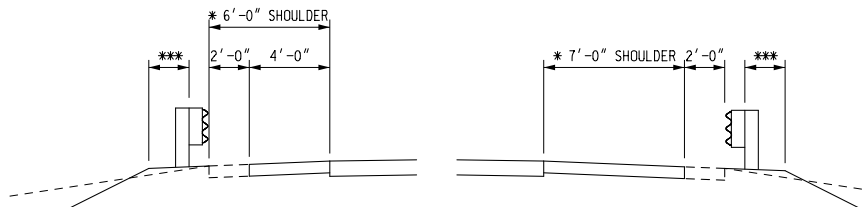

16' RAMPS



TWO-WAY ROADWAYS

Note: These sections should be used strictly for locating guardrail in relation to the edge of shoulder and are not intended to determine shoulder paving or shoulder widening requirements.

* See [Section 6.05.04D](#) for paved shoulder widening at guardrail sections.

** The 2' offset from face of guardrail to edge of shoulder should not be used if the paved shoulder width is at least 12'.

*** 2'-0" (min) with Guardrail Types B and T. 2'-8" (min) with Guardrail, Type MGS-8. Longer guardrail posts are required if the minimum offset requirements cannot be achieved. Refer to Standard Plan R-60-Series for guardrail post length and offset from shoulder hinge point requirements.

ROAD DESIGN MANUAL ROAD DESIGN

7.01.30 (continued)

Guardrail at Embankments

C. Maximum Height of 1:2 Slope Without Barrier

Barrier is not warranted on 1:2 fill slopes up to about 5' height. See [Section 7.01.30A](#), Height-Slope Guidelines.

D. Flattening Slopes to Eliminate Guardrail

On limited access projects, guardrail may be eliminated if the fill slopes are flattened to 1:4 or flatter. In order to eliminate guardrail on free access projects, the fill slope should also be flattened to 1:4 or flatter, unless additional R.O.W. would be required. If there are no obstacles or severe inclined slopes within the clear zone or at the toe of the fill slope, a 1:3 slope or flatter may then be considered.

E. Length of Barrier at Embankments (New Construction)

When determining the length of barrier required to shield an embankment slope (does not apply to barn roof sections), the designer must first determine the beginning of the 1:4 slope and where the slope steepens to 1:3. Using Standard Plan R-59-Series, which shows flared installations, the limits of the endings can be determined. Field personnel should check the length and slope rate of the fill section and make any necessary adjustments; sometimes the length will be adequate, but it may be necessary to "slide" the barrier one way or the other to fit actual conditions.

7.01.30 (continued)

F. Length of Barrier at Embankments (Upgrading Projects)

When a flared guardrail installation is not feasible and a parallel guardrail installation must be used, the following chart and diagram should be used to determine the length of barrier needed in advance of a 1:3 slope.

GUARDRAIL AT EMBANKMENTS (PARALLEL INSTALLATIONS)				
HEIGHT OF FILL AT 1:3 (ft)		LENGTH OF NEED IN ADVANCE OF 1:3 (ft)		
OVER	TO	70 mph	60 mph	50 mph
5	10	147	121	100
10	12	197	171	122
12	14	235	205	153
14	16	269	238	179
16	18	296	262	198
18	20	316	280	212
20	22	331	294	223
22	24	343	305	231
24	25	349	309	235

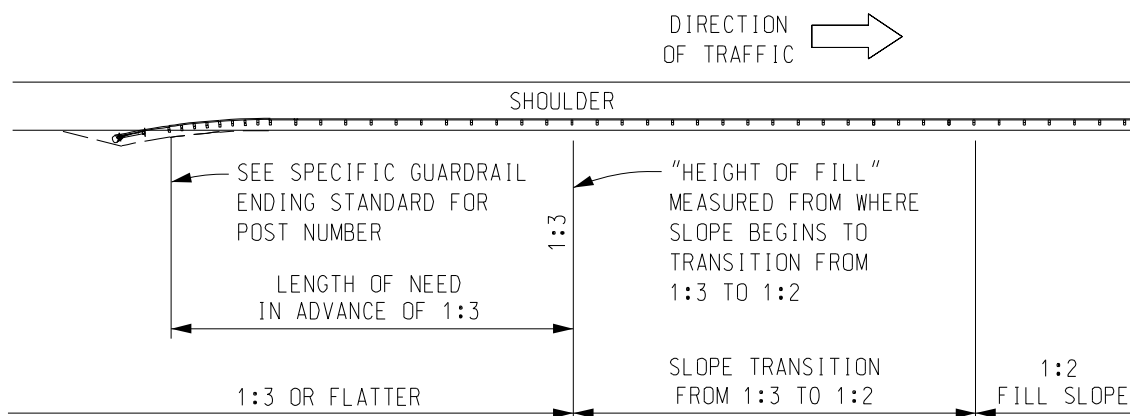

ROAD DESIGN MANUAL ROAD DESIGN

7.01.30 (continued)

Guardrail at Embankments

G. Placing Beam Guardrail on a Downslope

Usually the greater the distance from the roadway that a barrier can be placed, the less chance there is of it being struck and less barrier length will be needed to shield the object. However, placing a barrier on a downslope close to the shoulder hinge point (approximately 12'-0" or less) introduces the potential for the barrier to be less effective because of the tendency for a vehicle, leaving the shoulder, to vault over it. The following guidelines therefore apply:

1. Beam guardrail may be placed on a slope, beyond the shoulder point, if the slope is 1:10 or flatter.
2. Generally, a 1:10 or flatter slope should not be constructed specifically to locate the barrier farther out.
3. The placement of Type MGS-8 guardrail on 1:8 slopes should be confined to the applications specified in [Section 7.01.32.F](#).
4. Usually, the installation of guardrail on a 1:6 slope is not recommended for new installations.

7.01.30 (continued)

H. Guardrail Placed near Intersecting Streets and Driveways

An intersecting street or driveway located near a roadside object or feature may prevent installation of the full length of barrier required along the main road. An example of this would be a bridge on a main road with an intersecting driveway located near the bridge.

The preferred solution is to close or relocate the intersecting street or driveway in order to install the full length of barrier required along the main road. A crash cushion or other impact attenuating devices may be used to shield a fixed object such as a bridge railing end, however, this may not provide the length of need required to shield other roadside objects or features in the vicinity.

When closing or relocating the intersecting driveway or street is not feasible, two possible solutions are given in the accompanying sketches. A second guardrail run in advance of the intersecting street or driveway should be considered when the vehicle's runout path does not intersect guardrail, or when the runout path intersects the departing terminal or the first 16.5 feet of the approach terminal attached to the curved run of guardrail. See Special Detail 21 for installing a curved guardrail run near an intersecting street or driveway. Also, graphical design methods are suggested when utilizing the proposed solutions depicted in the accompanying sketches.

Site-specific constraints must be taken into consideration when designing guardrail near intersecting streets and driveways. Examples of these constraints include limited intersection sight distance, right-of-way limitations, and the presence of multiple intersecting driveways in close proximity to each other. In addition, the use of excessively short advanced guardrail runs should be avoided. Questions regarding guardrail installations near intersecting streets and driveways should be directed to the Geometric Design Unit of the Design Division.

ROAD DESIGN MANUAL

ROAD DESIGN

7.01.30 (continued)

Guardrail at Embankments

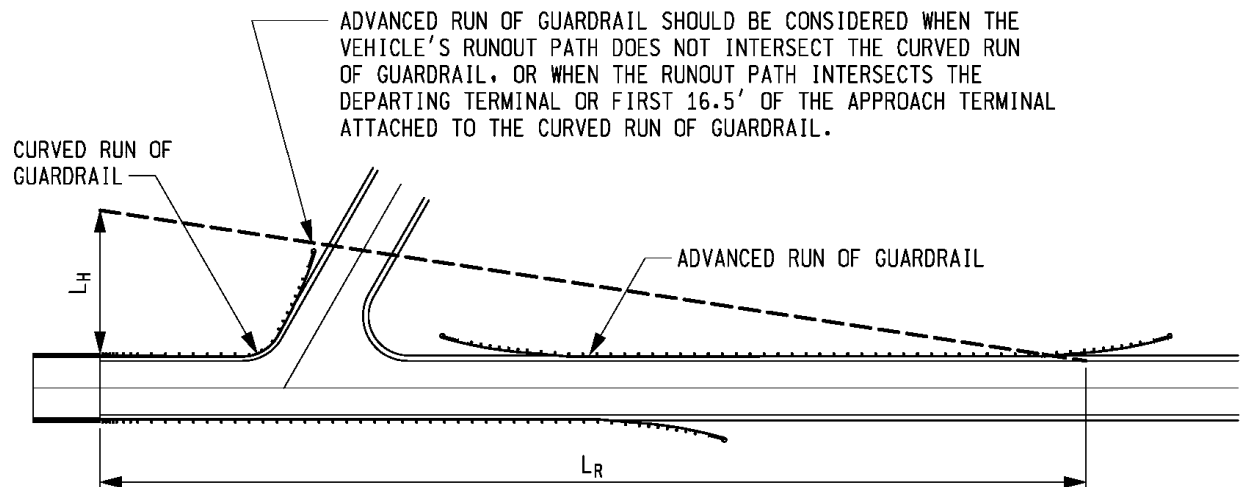
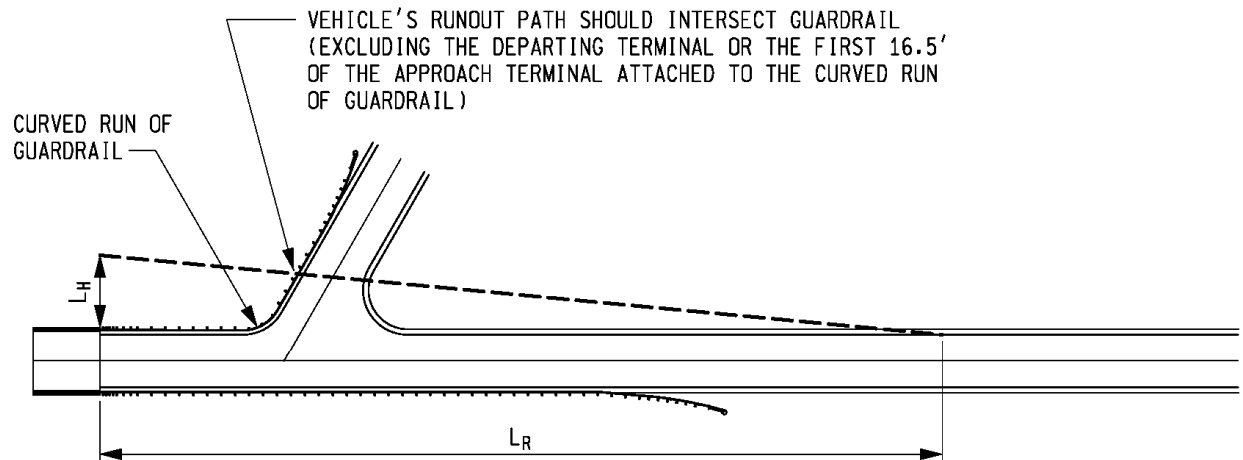

ROAD DESIGN MANUAL ROAD DESIGN

7.01.31 (revised 4-24-2023)

Shielding Bodies of Water

Warrants for shielding streams or permanent bodies of water are judgement decisions based on location and depth of water and likelihood of encroachment (page 5-9, 2011 AASHTO, *Roadside Design Guide*). Streams or permanent bodies of water more than 2'-0" in depth will usually require shielding by a barrier if within the clear zone. Barrier may also be required for bodies of water beyond the clear zone if, in the judgement of the designer, there is greater than usual potential for an errant vehicle to enter the water. An exception may be water close to the road for a considerable distance (a causeway is a case in point). In this case, speeds may have been correspondingly reduced because the roadside might be heavily used for recreational access to the water and for fishing. An intermittent barrier leaves many exposed endings to treat and space may not be available for proper flaring of the ends. After all factors are taken into consideration, it may be decided that the disadvantages of a barrier outweigh the advantages.

7.01.32 (revised 4-24-2023)

Barrier at Bridge Approaches (Over and Under)

Besides shielding embankments, the other most common use of a roadside barrier is shielding massive structural components. These fall into two general categories, the overpassing structure (approaches and railings) and the under passing structure (piers, drainage structures, and abutments).

A. Attachment to Barriers and Closer Post Spacings

Guardrail beam elements fastened to concrete structures should overlap the concrete sufficiently to place the end bolts as shown in Standard Plan R-67 Series. This is necessary to ensure proper guardrail anchorage to the concrete structure.

All of the guardrail anchorage, bridge attachments specified on Standard Plans R-67-Series, B-22-Series and B-23-Series increase in lateral stiffness. This is done to keep an impacting vehicle from displacing the guardrail and pocketing against the rigid bridge structure. The transition for lateral stiffness of guardrail is described in [Section 7.01.21](#). Additionally, heavier 10 gage (0.135") three-beam elements and nested 12 gage (0.105") beam elements, consisting of two stacked beam elements, are used to increase barrier strength to reduce the possibility of rail rupture.

ROAD DESIGN MANUAL ROAD DESIGN

7.01.32 (continued)

Barrier at Bridge Approaches (Over and Under)

B. Relationships Between Bridge Sidewalk and Approach Guardrail

Any guardrail run leading up to a bridge must be properly anchored to a bridge railing. Refer to Standard Plans R-67-Series, B-22-Series and B-23-Series. If curbs are present, the guardrail in conjunction with curb guidelines described in [Section 7.01.34](#) should be followed when site conditions allow. Contact the Geometric Design Unit, Design Division if there are any questions regarding specific situations.

7.01.32 (continued)

C. Barrier at the Trailing End of Overpassing Structures

The departing end of a bridge railing on a bridge carrying one-way traffic is generally not considered a hazard. However, there could be other hazards beyond the bridge, such as a slope steeper than 1:3, that may justify guardrail installation on the departing end of a bridge railing carrying one-way traffic.

Where a roadway carries two-way traffic, guardrail may be needed on the trailing end of the bridge railing because the trailing end for one direction of traffic is the approach end of the other. The designer should determine if the opposite side railing and any roadside hazards are within the clear zone, measured from the centerline in the case of a two-way, two-lane roadway.

If one or more downspout headers are required on the departing end of a one-way bridge, it will be necessary to shield it with guardrail. This guardrail should extend a minimum length of the Guardrail Departing Terminal beyond the last downspout header.

When a major railing or bridge reconstruction project is programmed, existing 12" high approach curbs on the departing ends of one-way bridges should be removed and replaced with a reduced height curb, unless shielding with a T-Series guardrail bridge anchorage. See current Standard Plans R-32 Series and R-67 Series for bridge approach curb and gutter requirements.

ROAD DESIGN MANUAL ROAD DESIGN

7.01.32 (continued)

Barrier at Bridge Approaches (Over and Under)

D. Shielding Requirements at Bridge Underpasses

The clear zone criteria presented in [Section 7.01.11](#) is the primary source of information used in determining whether bridge columns or abutments require shielding. Because a clear zone distance cannot always be determined precisely, it may happen that a fixed object thought to be outside the clear zone may need shielding. When this occurs, the designer must determine a method to shield them. Accepted methods for shielding are specified on the standard plans. If the only requirement is to shield the bridge pier or abutment, the barrier length should be calculated using the information found in [Section 7.01.05F](#).

Current bridges are usually designed with longer spans, so that bridge columns and abutments can be placed outside the clear zone. Even when spans are increased, not all bridge columns and abutments can be located outside clear zones. An example might be where a widened clear zone results from a bridge being located over a curved roadway.

Currently, the approach bridge fill, behind the abutment, is designed to have a 1:6 slope facing oncoming traffic on the road below. However, when the approach slope is not 1:6 or flatter, additional barrier may be required to obtain the required runout length used in the above formula.

7.01.32 (continued)

E. Guardrail Median Object Protection

Standard Plan R-56-Series illustrates an enclosed guardrail system for shielding objects such as bridge piers and sign supports in medians 36' to less than 70' in width. The system encloses the median objects between two parallel runs of guardrail converged and terminated at each end with a Type 3 approach terminal (Standard Plan R-63-Series). Details are provided for both Type T and Type MGS-8 guardrail (see Standard Plan R-60-Series). Therefore, it is necessary to specify the guardrail type to be used at each location. This design replaces the past versions of Standard Plan R-56-Series featuring the Minnesota Bullnose design. The current standard also provides details for a direct connection to filler walls. This connection detail requires construction of concrete end walls and reduces the overall guardrail length required.

Standard Plan R-56-Series also details a treatment for shielding the opening between twin-bridge approaches. For wider medians at twin bridge approaches, the barrier length should be calculated using the information found in [Section 7.01.05F](#).

It is necessary to ensure the minimum offset is provided from the edge of pier or median objects to the back of guardrail posts, while ensuring there is adequate space from the face of guardrail to the edge of shoulder. In cases where the minimum offset from the edge of pier or median objects to the back of guardrail posts cannot be satisfied, it may be possible to stiffen the guardrail system by decreasing the post spacing (see [Section 7.01.20](#), "Guardrail Deflection"). However, in cases where it is impossible to meet the minimum offset from the edge of pier or median objects and/or provide adequate space between the guardrail and the shoulder, concrete barrier should be considered for shielding the bridge piers or median objects. Consult with the Geometric Design Unit, Design Division for guidance.

ROAD DESIGN MANUAL ROAD DESIGN

7.01.32 (continued)

Barrier at Bridge Approaches (Over and Under)

F. Bridge Columns and Foundations in 70' Medians

Bridge columns and sign support foundations located in the center of 70' medians were once considered outside the clear zone. Shielding is now required and should be included in any programmed project upgrading.

The treatment for shielding columns and foundations for new construction and reconstruction projects should be according to the enclosed system designs shown on Standard Plan R-56-Series, Guardrail Median Object Protection.

In addition to the enclosed systems discussed in the previous section, an open system is detailed in Standard Plan R-56-Series for other than new construction and reconstruction projects with 70' medians and existing fill slope rates of 1:8 or flatter. This detail features twin parallel guardrail runs that shield the median objects independently for each direction of traffic. This option offers the advantage of better accessibility for maintenance equipment to service the median or sign foundations. It is intended only for the conditions stated above.

7.01.33 (revised 4-24-2023)

Maintaining Guardrail Strength When One or More Posts Must Be Omitted

A. Downspout Headers

Standard Plan R-32-Series, under "Notes", advises field personnel to determine the location of proposed guardrail posts prior to locating the spillway or downspout header(s). If this is done, there will be no conflict. There are occasions however, when miscalculation in construction layout or when upgrading guardrail, that an existing downspout header will prevent a post from being placed at the proper spacing. Downspout headers that were constructed prior to 1970 and according to Standard Plan E-4-A-144 series, are an example. These downspouts had deeper throats and were designed to fit 12'-6" post spacing. When a post cannot be properly placed, Standard Plan R-72-Series, "Guardrail Long Span Installations" should be considered.

B. Wide Culverts

Maintaining the continuity of the barrier strength is also necessary when a run of guardrail spans a wide culvert and the proper embedment of a guardrail post(s) cannot be obtained. When the spanning of a wide culvert requires the omission of one or two posts, Standard Plan R-72-Series, "Guardrail Long Span Installations" should be used. Where no barrier wall exists and the span is over 25'-0" Standard Plan R-73-Series, "Guardrail over Box or Slab Culverts" may be considered.

ROAD DESIGN MANUAL ROAD DESIGN

7.01.33 (continued)

Maintaining Guardrail Strength When One or More Posts Must Be Omitted

C. Placing Guardrail in Rock

Rock formations, which occur more frequently in the Upper Peninsula, may prevent the full embedment of guardrail posts. When only a partial embedment of posts can be obtained, backing the guardrail according to the method illustrated in Standard Plan R-72-Series is an option to individually drilling each hole. If the number of post locations in the influence of the rock formation would force the length of the backed guardrail section to exceed that allowed in the standard, the affected posts holes will have to be drilled. If the depth of soil overlying the rock formation is 18" or greater, the hole diameter required for steel posts is 8" (12" for wood) and full post embedment depth is required. If the depth of soil overlying the rock formation is less than 18", the hole diameter required for steel posts is 21" (23" for wood) and a 24" embedment depth into the rock is required. A strong-post W-beam guardrail exhibits better performance if the post is allowed to rotate in the soil. Thus, the post should not be placed in the center of the hole, but at the front, so the backfill is behind the back of the post. This work should be included by special provision.

7.01.33 (continued)

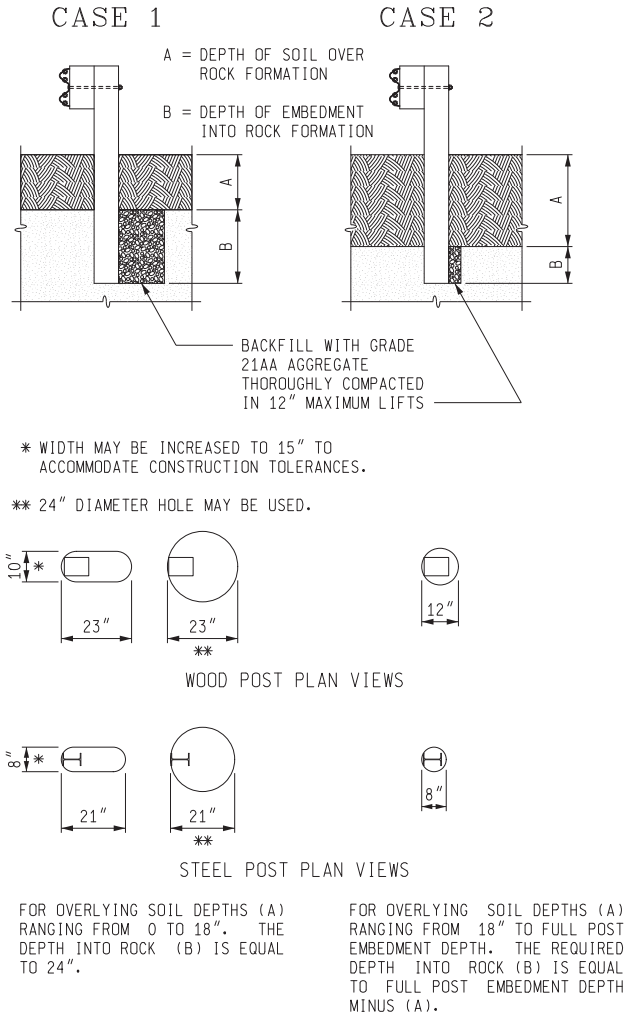

ROAD DESIGN MANUAL ROAD DESIGN

7.01.33 (continued)

Maintaining Guardrail Strength When One or More Posts Must Be Omitted

D. Guardrail Posts through Paved Surfaces

Guardrail posts embedded into paved surfaces present a problem similar to that of guardrail posts in rock formations. The paved surface will not allow the posts to rotate in their embedment (to distribute vehicle loads through the post into the embedment material) prior to breaking. Thus, an area of pavement around the post known as "leave out" must be omitted to allow the post to rotate. For both steel and wood posts, the size of the leave out should be an area of about 15" x 15" (square or round). The most critical measurement is the distance from the back of post to the back edge of the leave out, which should be a minimum of 7". After post installation, patching material is generally placed around the guardrail post in the "leave out" area. This work should be included by special provision.

7.01.33 (continued)

E. Additional Blockouts on Guardrail Posts

Double blockouts (16" deep) may be used to increase the post offset to avoid obstacles such as curbs. Except at terminals, there is no limit to the number of posts in a guardrail run that use double blockouts. Under special circumstances, one or two posts in a run of guardrail may employ as many as four blockouts (up to 36") to provide proper clearance. There should be no voids between blockouts when using double or multiple blockouts. Furthermore, for aesthetic reasons, double or multiple blockouts should be installed without creating sudden changes in guardrail alignment.

When using double or multiple blockouts, steps must be taken to prevent the placement of guardrail posts on steep fill slopes beyond the shoulder hinge point. Placing conventional length guardrail posts on steep fill slopes may result in posts having insufficient soil embedment depth, thereby reducing the post's strength to resist overturning. See [Section 7.01.41.D](#), 8'-0" Posts, for guardrail post length requirements when placing guardrail at or near the shoulder hinge line.

ROAD DESIGN MANUAL ROAD DESIGN

7.01.34 (revised 10-21-2013)

Guardrail in Conjunction with Curb

When a vehicle strikes a curb, the trajectory of that vehicle depends upon several variables including the size and suspension characteristics of the vehicle, its speed and angle of impact, and the height and shape of the curb itself. Generally, the use of curb on high speed roadways (design speed greater than 50 mph) is discouraged.

If guardrail/curb combinations are used when design speeds are less than 45 mph, the curb height should be 6" or less, with the face of guardrail being located either flush with the face of curb or at least 8' behind it.

For design speeds of 45 mph or 50 mph, a 6" curb (or less) may be used if the guardrail is located flush with the face of curb. If an offset from the curb is desired, the curb height should be 4" or less with the guardrail being located at least 13' behind the curb.

If guardrail/curb combinations are necessary when the design speed is greater than 50 mph, a mountable curb (Type D curb or valley gutter) should be used, and the curb height should be 4" or less, with the face of guardrail being located flush with the face of curb.

When guardrail is located flush with the face of curb, the rail height should be measured from the front edge of the gutter pan, which is the point on the gutter pan that is closest to the edge of the traveled lane. At greater distances (typically 8'-0" to 13'-0") the rail height should be measured from the ground just in front of the guardrail.

7.01.34 (continued)

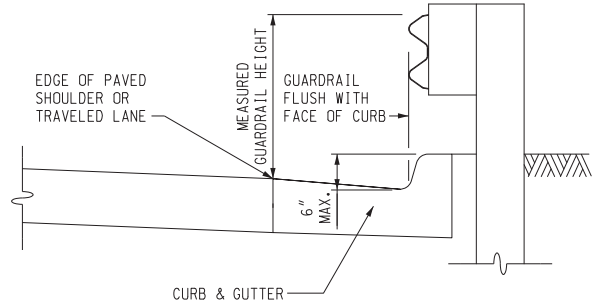

GUARDRAIL WHEN CURB IS ADJACENT TO
EDGE OF PAVED SHOULDER OR TRAVELED LANE
(DESIGN SPEED 50 mph OR LESS)

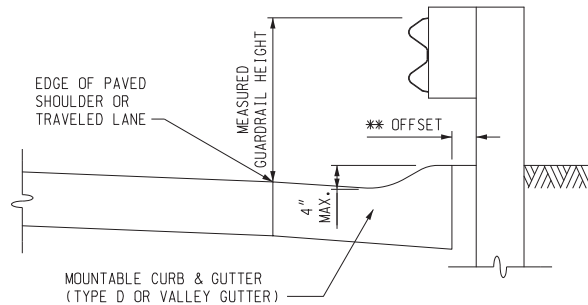

** 2" WHEN CURB IS PLACED NEXT TO SHOULDER
10" WHEN CURB IS PLACED NEXT TO TRAVELED LANE

GUARDRAIL WHEN CURB IS ADJACENT TO
EDGE OF PAVED SHOULDER OR TRAVELED LANE
(DESIGN SPEED GREATER THAN 50 mph)

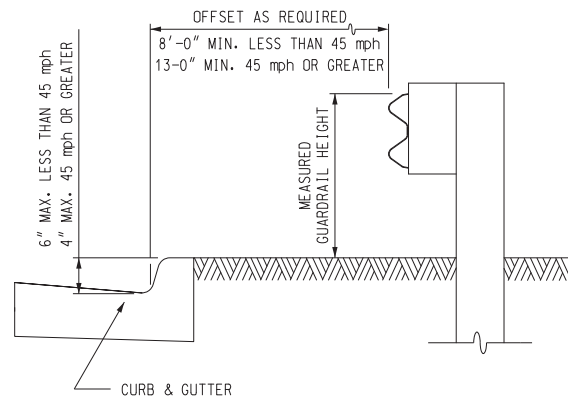

GUARDRAIL - CURB OFFSET
WHEN GUARDRAIL IS PLACED AWAY FROM CURB

ROAD DESIGN MANUAL ROAD DESIGN

7.01.40

Guard Posts for Roadside Control

Barrier systems should not be used merely for roadside control. Where it is impractical to use curb for this purpose, wooden posts without connecting beam elements will suffice. These posts should be weakened by adding two 3½" diameter holes, through the 8" face and 6" apart, with the bottom one about 1" above the ground. The holes should be perpendicular to traffic. Posts may be about 5'-0" apart or as necessary to control traffic in the specific situation. See Standard Plan R-74-Series.

7.01.41 (revised 4-24-2023)

Upgrading and Replacement of Guardrail

The upgrading and replacement of existing guardrail runs is a leading construction item in Michigan. Two principle reasons for updating are an obsolete design or because of changed conditions, e.g., a guardrail made too low by resurfacing the shoulder.

A. Guidelines for Upgrading or Replacing Guardrail

1. If entire runs of guardrail must be replaced because the guardrail is out of specifications or cannot be adjusted to meet specifications, then the guardrail should be replaced following the current MDOT recommendations as called for in [Section 7.01.12](#).
2. Height adjustment may be made on existing guardrail posts that pass a thorough inspection for soundness. Existing beam elements should be evaluated for expected life and may be used if they meet current design standards. If the existing guardrail cannot be made to meet these conditions, then the entire run should be replaced with new guardrail using the recommended type from [Section 7.01.12](#).

ROAD DESIGN MANUAL ROAD DESIGN

7.01.41A (continued)

Upgrading and Replacement of Guardrail

3. When replacement of the existing guardrail on freeway ramps is necessary, use Type MGS-8. If a continuous guardrail run is needed up to and along the crossroad, with Type B guardrail along the crossroad, transition Type MGS-8 to Type B at a point 50'-0" minimum from the edge of the crossroad for a "T" intersection ramp terminal. For a continuous run through a free-flow ramp, with Type B guardrail along the free-flow ramp, transition to Type B opposite the 2'-0" point in the gore. This should be done at both on and off ramp terminals.
4. Height adjustments may be made to guardrail meeting the conditions stated in 2 of this section. If the existing posts are too low to allow the thrie beam rail to be placed at the proper height, then new guardrail should be installed.

The placing of the upper bolt shall not be closer than 2" from top of wood or steel posts. See the following illustrations.

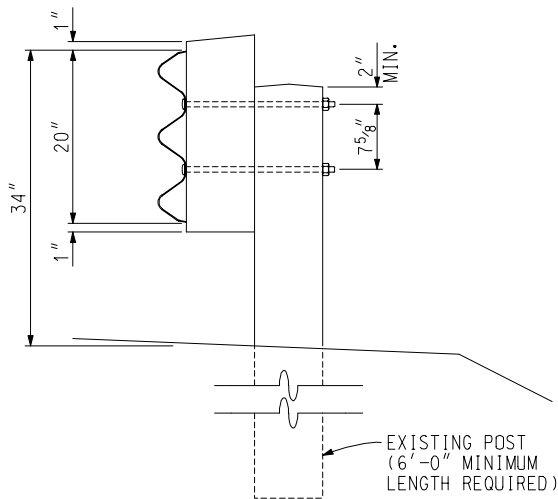

ADJUSTING THRIE BEAM GUARDRAIL
HEIGHT ON EXISTING WOOD POSTS

7.01.41A (continued)

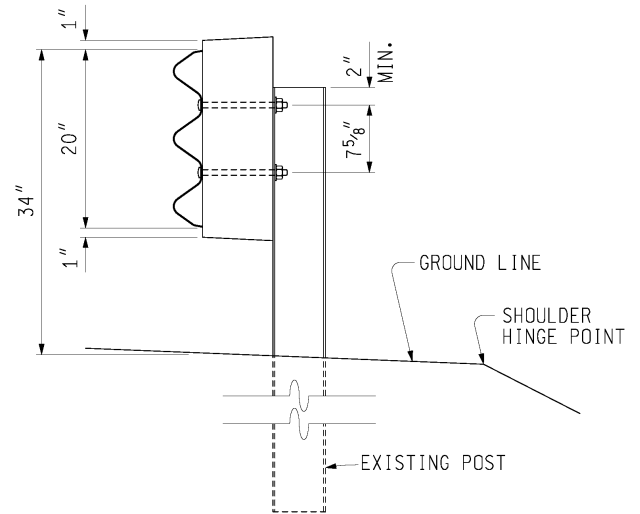

NOTE: HOLES IN STEEL POST SHALL BE DRILLED NOT BURNED.

ADJUSTING THRIE BEAM GUARDRAIL
HEIGHT ON EXISTING STEEL POSTS

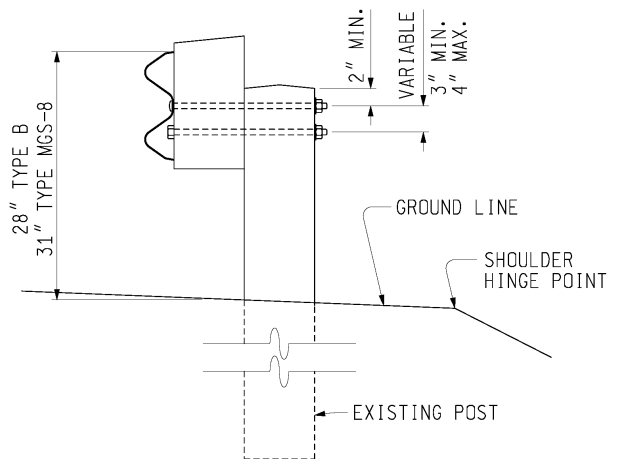

ADJUSTING TYPE B OR TYPE MGS-8
GUARDRAIL HEIGHT ON
EXISTING WOOD POSTS

ROAD DESIGN MANUAL

ROAD DESIGN

7.01.41A (continued)

Upgrading and Replacement of Guardrail

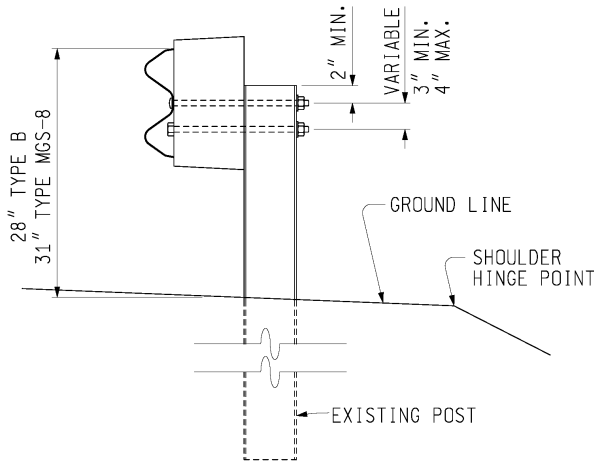

ADJUSTING TYPE B OR TYPE MGS-8
GUARDRAIL HEIGHT ON
EXISTING STEEL POSTS

7.01.41 (continued)

B. Upgrading Guardrail Terminals

MDOT policy is to replace any Breakaway Cable Terminals (BCT) encountered on all trunkline projects, including both 3R and 4R projects, NHS and non-NHS routes, all guardrail runs within the projects limits (both flared and non-flared), and regardless of whether guardrail work is included as part of the project. See Standard Plan R-62-Series for details of approved terminals.

These guidelines do not apply to Capital Preventive Maintenance (CPM) projects. Safety Criteria for CPM projects are covered under a separate agreement with the FHWA.

Maintenance forces are to replace a damaged BCT with an approved terminal from Standard R-62-Series.

ROAD DESIGN MANUAL

ROAD DESIGN

7.01.41 (continued)

Upgrading and Replacement of Guardrail

C. Intermixing Wood and Steel Posts

At the present time, the Standard Specifications permit the use of either wood or steel guardrail posts. Both types of posts may be randomly intermixed in making repairs on Types A, B, T, and MGS-8 guardrail, but, for appearance, complete runs being reconstructed should utilize only one type of post.

Posts in terminals shall be the same as those specified on Standard Plans R-62-Series, R-63-Series, R-66-Series and the special provision which specifies the Type 2M endings. When the repair of an existing bullnose installation is necessary, wood posts shall be used.

D. Guardrail Posts at or near the Shoulder Hinge Line

Guardrail upgrading on local roads and trunklines sometimes requires setting the posts at or near the shoulder hinge line rather than 2'-0" (shoulder hinge point to front face of post) for Guardrail Types B and T, or 2'-8" (shoulder hinge point to front face of post) for Guardrail Type MGS-8, as specified on Standard Plan R-60-Series. Most of the time this condition occurs on a fill, which means that the soil support behind the post will be reduced because of the close proximity of the slope. In these cases, 8'-0" long posts should be specified for Guardrail Types B and T, and 9'-0" long posts should be specified for Guardrail Type MGS-8. If the ground does not fall away behind the guardrail, then conventional length posts are sufficient. These requirements also apply to double sided guardrail (Guardrail Types BD, TD, and MGS-8D).

7.01.41 (continued)

E. Allowable Variation from Standard Height

When evaluating existing guardrail to determine upgrading needs, variation from standard barrier height is a consideration. A variation of 3" from the standard height is allowable. This is considered a functional variation. Closer tolerances are expected for construction purposes. If an existing guardrail is of the proper type, and after all phases of the proposed project are complete, e.g., shoulder resurfacing, etc., the guardrail height should be within this limit. If any work must be done on it at all, however, then the run should be brought up to standard. Before allowing such a run of guardrail to remain untouched, it should pass a thorough inspection for the soundness of posts and the expected remaining life of the beam elements. The timing of future road improvements should also be a consideration.

F. Unpainted Corrosion Resistant Beam Elements

See [Section 7.01.14B](#). The Engineering Operations Committee meeting on January 20, 1989 decided that all existing corrosion resistant, or "rusty steel", guardrail encountered on proposed Interstate resurfacing or reconstruction projects should be removed and replaced as part of the project.

On projects involving bridges only, the nominal provisions of approach guardrail (guardrail anchorage to bridge and approach terminal) shall be replaced if the rail elements are rusty steel. Where guardrail at the bridge approaches is part of a more extensive installation, the decision to replace will be made on the merits of the specific project.

ROAD DESIGN MANUAL ROAD DESIGN

7.01.41 (continued)

Upgrading and Replacement of Guardrail

G. Thick Shoulder Lifts

Rehabilitation of rural freeways often entails placing a new concrete pavement on top of the old, or placing a thick HMA overlay. This procedure also raises the shoulder elevation, thus causing the existing guardrail to be too low. When this occurs, the designer is reminded that provisions should be made to either reconstruct or upgrade the guardrail.

If reconstruction of the guardrail must precede the pavement lift by a year or so; the designer may be tempted to call for longer than normal posts, leaving them with tops protruding so that they will be long enough to fit the ultimate installation. This should not be done; crash test films frequently show the impacting vehicle laying over on the rail and sliding along it. Protruding post tops would thus have a detrimental effect on smooth redirection of the vehicle.

H. Type A Guardrail Parallel to Continuous Abutment, Twin Overpassing Structures

It was practice for a number of years to place Type A guardrail in front of the opening between twin overpassing structures, parallel to the continuous abutment and about 4'-0" in back of it. Current standards provide either a length or a configuration of guardrail that eliminates the need for this transverse section of barrier. On an updating project, if this transverse barrier is still in place and in good condition, it may be left as a deterrent to persons or animals who could accidentally fall over the backwall. If the condition of the barrier warrants removal, replacement is not necessary. However, replacement may be considered if deemed essential to provide positive protection for mowing operations and/or other maintenance purposes.

7.01.41 (continued)

I. Replacing with Thrie Beam Guardrail

Even though guardrail Type T and Type MGS-8 are the current standards for use on freeways, other guardrail types do not need to be replaced unless physical deficiencies exist.

7.01.43

Guidelines for Bridge Railing Replacement and Attached Approach and Trailing Guardrails

See [Chapter 12](#) of the Bridge Design Manual.

7.01.44 (revised 10-22-99)

Guardrail Upgrading on Local Roads

A. Guardrail Upgrading Guidelines on Local Roads (In Conjunction with Freeway Work)

In conjunction with work programmed on a freeway, the Department may have occasion to upgrade guardrail on roads that are under local jurisdiction. Generally, the guardrail will be constructed to "trunkline standards" with respect to the type of guardrail and the type of ending. Depending on site conditions, the location and configuration of the guardrail used on local roads may not necessarily be to "trunkline standards".

The Department attempts to prevent errant local road traffic from encroaching on the freeway and its appurtenances. The following guidelines have been established for upgrading guardrail on local roads over and under freeways.

ROAD DESIGN MANUAL ROAD DESIGN

7.01.44A (continued)

Guardrail Upgrading on Local Roads

1. If the major work is on the crossroad, the approach guardrail will be upgraded. For ADT less than 2000 and the operating speed 50 mph or less, 200' of approach guardrail can be considered as satisfying the runout length (L_R) from the bridge railing end, pier or abutment. See table for runout length (L_R) in [Section 7.01.19](#). If the ADT on the crossroad exceeds 2,000 or the operating speed exceeds 50 mph, the type of guardrail shall be as specified in [Section 7.01.12](#) and the lengths computed using the worksheet in [Section 7.01.05F](#). If the total length of the existing run is not more than 100' longer than the computed length, then the entire run should be constructed. If the run is considerably longer, then simply connect the upgraded guardrail to the existing guardrail at the 200' cut-off point.
2. If the major work is on the freeway, then no guardrail upgrading need be done on local roads, over or under, except in interchange areas. The limits of upgrading the guardrail in interchange areas should be between the crossroad ramp terminals.
3. When the major work is on the freeway, upgrading older local road bridge railings with guardrail retrofits or new railings will not be required. See [Chapter 12](#) of the Bridge Design Manual for instructions on bridge rail upgrading.

7.01.44A (continued)

4. A typical urban depressed freeway will generally not require a guardrail installation or upgrading because the local street is probably at grade with the service streets on each side of the freeway and the bridge railing endings are a short distance from the edge of the intersecting service streets. These local streets are usually curbed and traffic is restricted to speeds less than 50 mph (usually 25 mph to 35 mph). In addition, low crash frequency and possible obstruction to vision also works against the use of guardrail in this situation. This is not to prohibit the use of a barrier at such approaches if different circumstances suggest the need.

B. Cul-de-sacs

Provide 75' of Type A guardrail at cul-de-sacs when a rural freeway intersects a local road and no grade separation is provided. See [Section 12.07.03](#) for a typical cul-de-sac. Terminal end shoes are placed at each end. The purpose of this guardrail is to alert the motorist using the local road that the road is not continuous.

C. Guardrail at Urban Service Road "T"

It was practice for many years to place a short section of guardrail adjacent to the fence opposite local streets dead-ending into urban service roads. This guardrail serves very little purpose because it will not stop a high-speed vehicle going through the intersection from the local street, and it is an additional obstacle for a vehicle to hit while traveling on the service road. It is therefore being omitted on new construction. Instead, a directional arrow sign is usually placed at the fence, and shrubs may be planted behind the fence to act as a screen or visual barrier.

ROAD DESIGN MANUAL ROAD DESIGN

7.01.44 (continued)

Guardrail Upgrading on Local Roads

D. Cable on Chain Link Fence

Cable on chain link fence consists of attaching 2 steel cables to a chain link fence. This treatment may be useful in urban freeway areas where a local street ends at a service road and where a chain link fence is located parallel between the freeway and service road. Its possible use might be at locations where there is greater than usual potential for an errant vehicle to go down onto the freeway. Details are available from the Standards Unit.

7.01.45 (revised 4-24-2023)

Alternative Barrier End Treatments

All the terminals discussed in this section have been crash tested as recommended by NCHRP Report 350 and approved by FHWA. As with all terminals where penetration behind and beyond the barrier can be expected, a traversable area, free of fixed objects, is recommended to aid post-crash vehicle stability. Alternative endings should be considered where restrictive site conditions exist, such as bi-directional traffic or two-sided directional traffic, and where the designer is unable to obtain the required offset, length, etc.

Note that this is not a comprehensive list of all alternative barrier end treatments, and future developments in the roadside safety industry will likely result in the availability of additional barrier end treatments. Consult with the Geometric Design Unit, Design Division, for additional information regarding alternative barrier end treatments.

7.01.45 (continued)

A. X-TENUator

The X-TENUator is an NCHRP 350, Test Level 3 compliant crash cushion manufactured by Barrier Systems (a Lindsay Corporation company), Vacaville, California. The X-TENUator may be used for both permanent and temporary applications, and may be used to terminate single-sided guardrail, double-sided guardrail, and concrete barriers. The X-TENUator is approximately 24'-9" long, and requires a concrete or asphalt base pad for installation. While the X-TENUator has a relatively low installation cost compared to other crash cushions, this device is considered to be a sacrificial unit that generally requires complete removal and replacement after a vehicular impact.

The X-TENUator may be desirable for restrictive site conditions, such as shielding concrete barrier or bridge railing endings at locations that prevent the installation of a traditional guardrail bridge anchorage and guardrail approach terminal. Designers should note that the X-TENUator requires 12'-6" of longitudinal clear space behind the unit on both sides of the object being shielded in order for the side panels of the X-TENUator to slide back and telescope when the unit is impacted.

Detailed information on design and installation is available from the Geometric Design Unit, Design Division.

ROAD DESIGN MANUAL ROAD DESIGN

7.01.45 (continued)

Alternative Barrier End Treatments

B. QuadTrend™

The QuadTrend system is a proprietary terminal manufactured by Energy Absorption Systems Inc. This device is for one-sided directional traffic and is intended for shielding concrete barrier endings, bridge railing endings, abutments, etc. This device can be attached directly to a rigid ending without a guardrail strength transition. Detailed design, construction and maintenance information is available from the Geometric Unit, Design Division.

7.01.45 (continued)

C. BEAT-SSCC

The BEAT-SSCC (Box Beam Bursting Energy Absorbing Terminal Single-Sided Crash Cushion) is an NCHRP 350, Test Level 3 compliant terminal manufactured by Road Systems Inc., Big Springs, Texas.

The BEAT-SSCC may be used for both permanent and temporary applications, and is intended for use as a single-sided terminal for shielding concrete barrier, bridge abutments/piers, and certain types of bridge railings. The BEAT-SSCC is available in the following lengths: 28', 32', 36', 40', and 44'. The BEAT-SSCC is available with driven (ground-mounted) posts or with surface-mounted posts for installation on a concrete surface. While the BEAT-SSCC has a relatively low installation cost compared to other crash cushions, this device is considered to be a sacrificial unit that generally requires complete removal and replacement after a vehicular impact.

The BEAT-SSCC may be desirable for restrictive site conditions, such as shielding concrete barrier or bridge railing endings at locations that prevent the installation of a traditional guardrail bridge anchorage and guardrail approach terminal.

Detailed information on design and installation is available from the Geometric Design Unit, Design Division.

ROAD DESIGN MANUAL ROAD DESIGN

7.01.50 (revised 5-22-2023)

Temporary Beam Guardrail

Beam guardrail may be used for temporary barrier applications when deemed appropriate based on intended usage, site conditions, and economic feasibility. Materials, including posts, may be of salvaged origin, and removal is included in the pay item. It is primarily used on construction projects where traffic is maintained along the existing road. While temporary concrete barrier is now used to a great extent, temporary guardrail may be a viable alternative provided proper guardrail installation is feasible based on site conditions. Temporary beam guardrail must be called for on plans when so requested by the Region/TSC. If specific installation locations are not shown on plans, a lump sum quantity and general note should be provided for the entire project on the Note Sheet, as follows:

Guardrail, Temp, Type __, __ inch Post __ ft
(To be used as directed by the Engineer)

In general, avoid estimating less than 200' total for a project, since a very small quantity may result in an exorbitant unit price.

Temporary beam guardrail has the same placement and installation requirements as permanent guardrail, but is usually not placed less than 6'-0" from the edge of traffic-carrying lanes. It may be used in areas where the pavement is located 20'-0" or less from the edge of excavations that exceed 5'-0" in depth, and which have a vertical face or slope of 1:2 or steeper.

7.01.50 (continued)

Temporary beam guardrail endings are handled in a similar manner as permanent guardrail endings. When a temporary beam guardrail ending is within the clear zone of approaching traffic, a crashworthy guardrail approach terminal or anchorage shall be used. Temporary guardrail departing terminals may be used when located beyond the clear zone of approaching traffic. Include the appropriate temporary guardrail approach terminal, departing terminal, and anchorage pay items and quantities, as needed. The temporary beam guardrail pay items are identified in Section 807 of the Standard Specifications for Construction.

ROAD DESIGN MANUAL ROAD DESIGN

7.01.54 (revised 10-21-2013)

7.01.54 (continued)

Warrants for Median Barriers on Freeways

Double thrie and double W-beam steel guardrail (semi-rigid), concrete median barrier (rigid) and Cable (Flexible) are considered equally suitable for reducing cross-median crashes. However, each has its application and each has its advantages and disadvantages. The designer should be knowledgeable of these when making decisions relative to which type of barrier to call for. The most desirable system is the one that satisfies the performance requirement

and costs the least to install and maintain. Section 5.2 of the 2011 AASHTO *Roadside Design Guide* summarizes the major factors which should be considered before making a final selection. The current median barrier warrants formulated for placing barrier in freeway medians were developed by the former Traffic and Safety Division, accepted by the Barrier Advisory Committee and approved by the Engineering Operations Committee at their February 4, 1992 meeting. The warrant table is shown below:

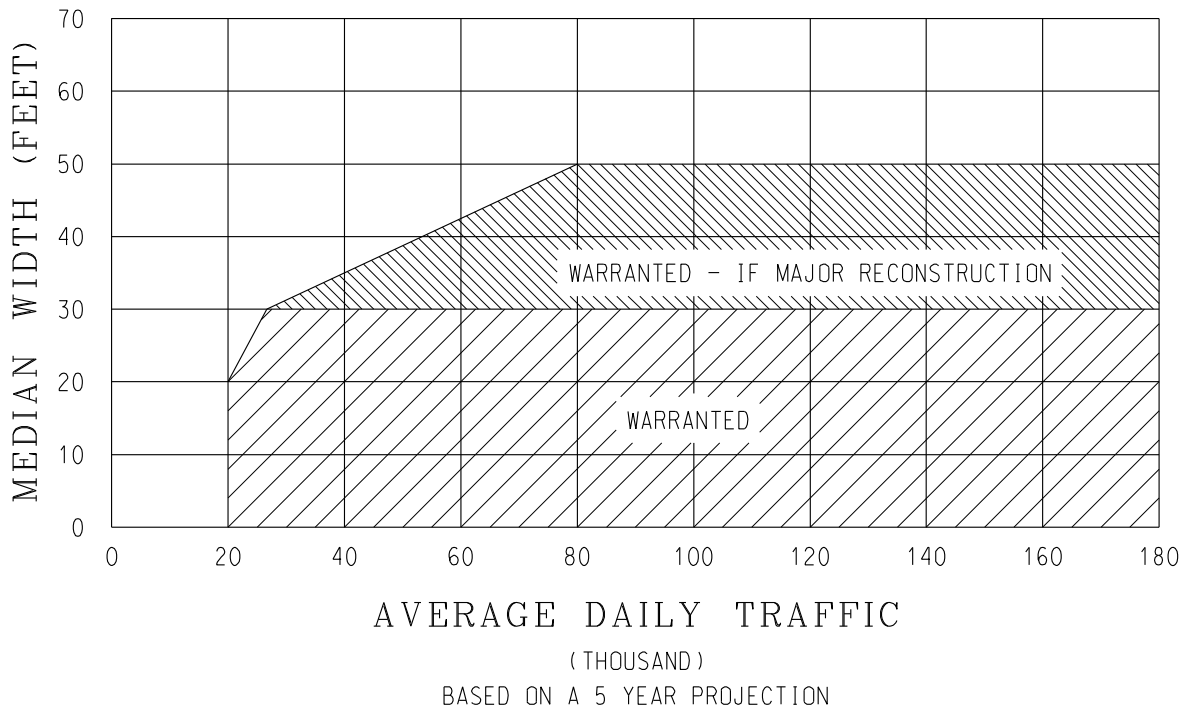
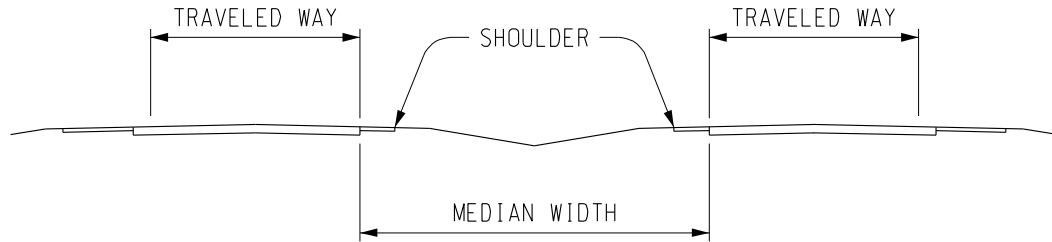

ROAD DESIGN MANUAL

ROAD DESIGN

7.01.55 (revised 4-24-2023)

Median Barrier Types

Median barriers, when used, are employed almost exclusively on controlled access highways. If the road is free access, openings would have to be provided at intersections and crossovers. This means that the barrier must be terminated at these points with a crash worthy end treatment. The lengths of the end treatments must be added to the length of the opening thus increasing the length of unprotected median, as the end treatments provide only marginal median crossover protection.

Generally, the initial installation cost of concrete median barrier is about 10-15% more than a double-sided metal guardrail. (However, this comparison does not include the possible additional cost of drainage alterations, etc., that might be required in conjunction with concrete barrier.) Advantages and disadvantages for the three barrier systems are as follows:

A. Concrete Median Barrier

Advantages

1. Very low maintenance.
2. Relatively good visibility.
3. Less vehicle damage at low angles of impact.
4. Easier on which to affix glare screen (glare screen can be integrally cast)

Disadvantages:

1. Greater “snow fence” effect (wind cannot pass through)
2. Traps blowing paper and trash
3. Usually requires some form of internal drainage
4. May require extensive grading. In most cases, adjacent slopes should be 1:10 or flatter.

7.01.55 (continued)

B. Double Steel Beam Guardrail

Advantages

1. May be used in the wider medians (median width not a factor)
2. Less “snow fence” effect than concrete barrier
3. Lateral drainage can flow under
4. Performs better than concrete barrier for high angle impacts
5. When placed along the top of a V-ditch, guardrail may be installed adjacent to a 1:6 backslope (Type TD) or 1:8 backslope (Type MGS-8D).

Disadvantages:

1. Maintenance repair usually required after a hit
2. Harder to install in rock
3. No durable glare screen available for mounting on top

C. Cable Barrier

General Guidelines

- Cable median barrier is recommended on divided roadways where:
 1. Median crossover crashes have been reported, and
 2. Median barrier is not warranted based on [Section 7.01.54](#) of the Michigan Road Design Manual.
- Median width should be a minimum of 30 feet.
- Median slopes shall be 1:4 or flatter.
- The cable barrier shall be placed at a location that permits the system to deflect unimpeded during a vehicular impact. The cable barrier shall not interfere with opposing traffic or other roadside objects during a vehicular impact. If a single run of cable barrier cannot satisfy the offset requirements, dual runs should be used.
- At locations where both NCHRP 350, TL-3 and TL-4 cable systems may be installed, NCHRP 350, TL-4 cable systems are preferred.

ROAD DESIGN MANUAL ROAD DESIGN

7.01.55C (continued)

Median Barrier Types

- The length of need (LON) for cable median barrier is based on engineering judgment. Consult with the Geometric Design Unit of the Design Division for additional information.
- Due to the advantages high-tension cable systems possess, high-tension cable systems are preferred over low-tension cable systems.

Approved Cable Median Barrier Systems

The following cable barrier systems are approved for use as median barrier. Questions regarding cable median barriers should be directed to the Geometric Design Unit of the Design Division.

A. Low-Tension Three-Cable Median Barrier (Type M Cable Barrier per Standard Plan R-70-Series)

This is a non-proprietary cable system that is described in the 2011 AASHTO *Roadside Design Guide* and MDOT Standard Plan R-70-Series. This design has been adopted by various agencies throughout the nation. The cable system and the end terminals have been successfully tested to NCHRP 350, TL-3.

Advantages:

1. Non-proprietary, usually less expensive than proprietary items
2. May be used on curved roadways with radii as low as 110 feet

Disadvantages:

1. Generally requires more maintenance than high-tension cable systems
2. System is usually inoperative after an impact (i.e., requires immediate inspection and maintenance after an impact)
3. Larger impact deflection compared to high-tension cable systems
4. Maximum length between terminals is considerably smaller than high-tension cable systems

7.01.55C (continued)

Table 1:

DESIGN CRITERIA FOR LOW-TENSION THREE-CABLE MEDIAN BARRIER		
Maximum Flare Rate	4:1	
Minimum Design Deflection Distance	16 feet	
Minimum Offset Between Median Ditch Line and Cable Barrier (Single Runs Only)	8 feet	
Maximum Length Between Terminals	2,000 feet	
Post Spacing and Roadway Curvature Requirements	RADIUS	POST SPACING
	Less than 110 feet	CABLE BARRIER NOT RECOMMENDED
	110 feet to 219 feet	6'-0"
	220 feet to 699 feet	12'-0"
	700 feet or more and Tangent Sections	16'-0"

ROAD DESIGN MANUAL ROAD DESIGN

7.01.55C (continued)

Median Barrier Types

B. High-Tension Cable Median Barrier

CASS Cable System

The CASS cable system is a proprietary, high-tension cable barrier manufactured by Trinity Industries, Inc. The system is available with I-shaped steel posts installed in concrete post foundations with a sleeve of steel, or a driven steel socket with a soil plate welded to the socket.

There are two versions of the CASS system in use on MDOT roadways.

The CASS 4:1 Slope cable barrier system is an NCHRP 350, TL-4 system when placed on 1:6 or flatter slopes. This system may also be placed on slopes steeper than 1:6, up to 1:4, and is NCHRP 350, TL-3 compliant under such conditions. This cable system consists of three 3/4" diameter pre-stretched cables, with the top and middle cables located in a slot in the middle of the post. The top and middle cables are separated by recycled plastic spaces. The bottom cable is placed on the side of the post and secured with J-hook fasteners. This is the most common version of the CASS system used on MDOT roadways.

The CASS TL-4 cable barrier system is an NCHRP 350, TL-4 compliant cable barrier system. This cable system consists of three 3/4" diameter pre-stretched cables, with all three cables located in a slot in the middle of the post and separated by recycled plastic spacers. This cable system can only be installed on 1:6 or flatter slopes. As a result of this limitation, it is used less often than the CASS 4:1 Slope cable barrier system.

In addition, the CASS cable terminal (CCT) is an NCHRP 350, TL-3 compliant end terminal for use with both CASS systems.

7.01.55C (continued)

Gibraltar Cable System

The Gibraltar cable system is a proprietary, high-tension cable barrier manufactured by Gibraltar Global, LLC. The system consists of steel posts installed in concrete post foundations with a sleeve of steel or a driven steel socket with a soil plate welded to the socket. Even though Gibraltar manufactures several cable barrier systems, the three-cable, Gibraltar TL-4 cable barrier system is the system commonly used on MDOT roadways. It meets NCHRP 350, TL-4 when placed on 1:6 or flatter slopes, but also meets NCHRP 350, TL-3 on slopes steeper than 1:6, up to 1:4. Furthermore, the Gibraltar cable terminal is an NCHRP 350, TL-3 compliant end terminal for use with the Gibraltar cable system. 3/4" diameter prestretched cables are attached to the posts and kept at the appropriate height by devices called "hairpins," which are unique to Gibraltar. The cables are tensioned according to cable temperature.

ROAD DESIGN MANUAL ROAD DESIGN

7.01.55C (continued)

Brifen Cable System

The Brifen cable system is a proprietary, high-tension cable barrier manufactured by Brifen USA, Inc. The system consists of steel posts installed in concrete post foundations with a sleeve of steel, or a driven steel socket with a soil plate welded to the socket, and four $\frac{3}{4}$ " pre-stretched cables. Three of the four cables are woven on alternating sides of sequential posts over the entire segment length. The cables are tensioned according to cable temperature.

The Brifen cable system used on MDOT roadways meets NCHRP 350, TL-4 when placed on 1:6 or flatter slopes, and also meets NCHRP 350, TL-3 when placed on slopes steeper than 1:6, up to 1:4. In addition, the Brifen WRGT end terminal is an NCHRP 350, TL-3 compliant end terminal for use with the Brifen cable system.

ROAD DESIGN MANUAL ROAD DESIGN

7.01.55C (continued)

Median Barrier Types

Advantages:

1. Typically impact deflection is 10 feet or less
2. Generally requires less maintenance than low-tension cable systems
3. Compared to low-tension cable barrier, high-tension cable barrier has a much higher probability of remaining operative after an impact

Disadvantages:

1. Systems are proprietary; more expensive than low-tension cable systems
2. System may be inoperative after an impact (i.e., usually requires immediate inspection and maintenance after an impact)
3. System is limited to curved roadways with radii of 650 feet and greater

7.01.55C (continued)

Table 2:

DESIGN CRITERIA FOR HIGH-TENSION CABLE MEDIAN BARRIER		
Maximum Flare Rate	30:1	
Minimum Design Deflection Distance	12 feet	
Minimum Offset Between Median Ditch Line and Cable Barrier (Single Runs Only)	10 feet	
Maximum Length Between Terminals	10,560 feet (2 miles) *	
Post Spacing and Roadway Curvature Requirements	RADIUS	POST SPACING
	Less than 650 feet	CABLE BARRIER NOT RECOMMENDED
	650 feet and greater	See Manufacturer's Specifications

* 2 miles is a suggested operational value, but longer runs are possible if the local TSC deems it acceptable.

ROAD DESIGN MANUAL ROAD DESIGN

7.01.55C (continued)

Median Barrier Types

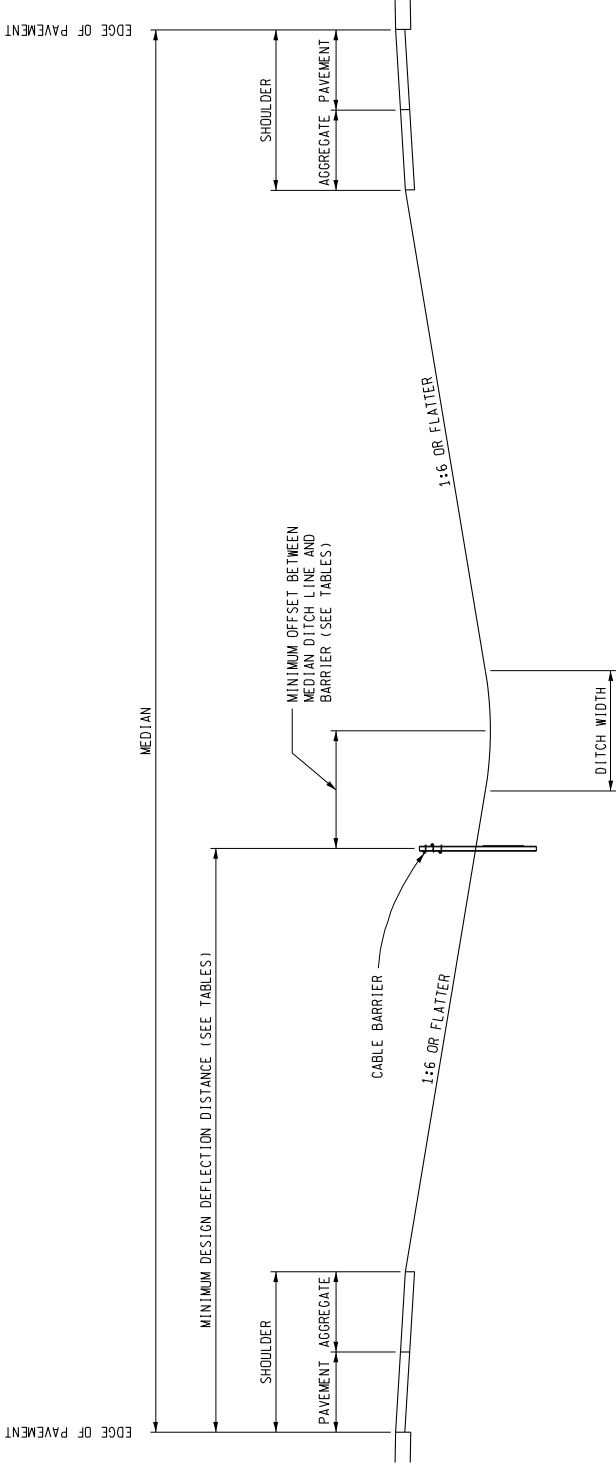

MEDIAN SLOPES 1:6 OR FLATTER

ROAD DESIGN MANUAL ROAD DESIGN

7.01.55C (continued)

Median Barrier Types

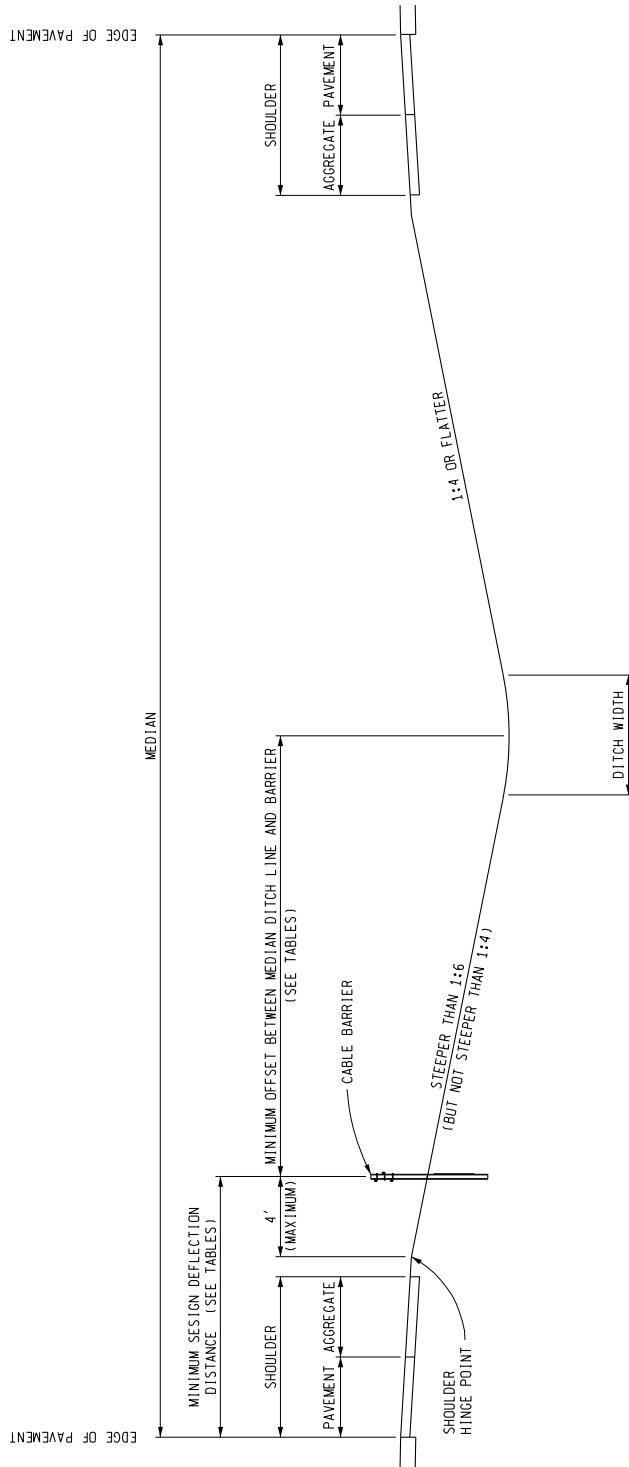

MEDIAN SLOPES 1:4 OR FLATTER
FOR CABLE SYSTEMS RATED FOR INSTALLATION ON 1:4 SLOPES

ROAD DESIGN MANUAL ROAD DESIGN

7.01.55C (continued)

Median Barrier Types

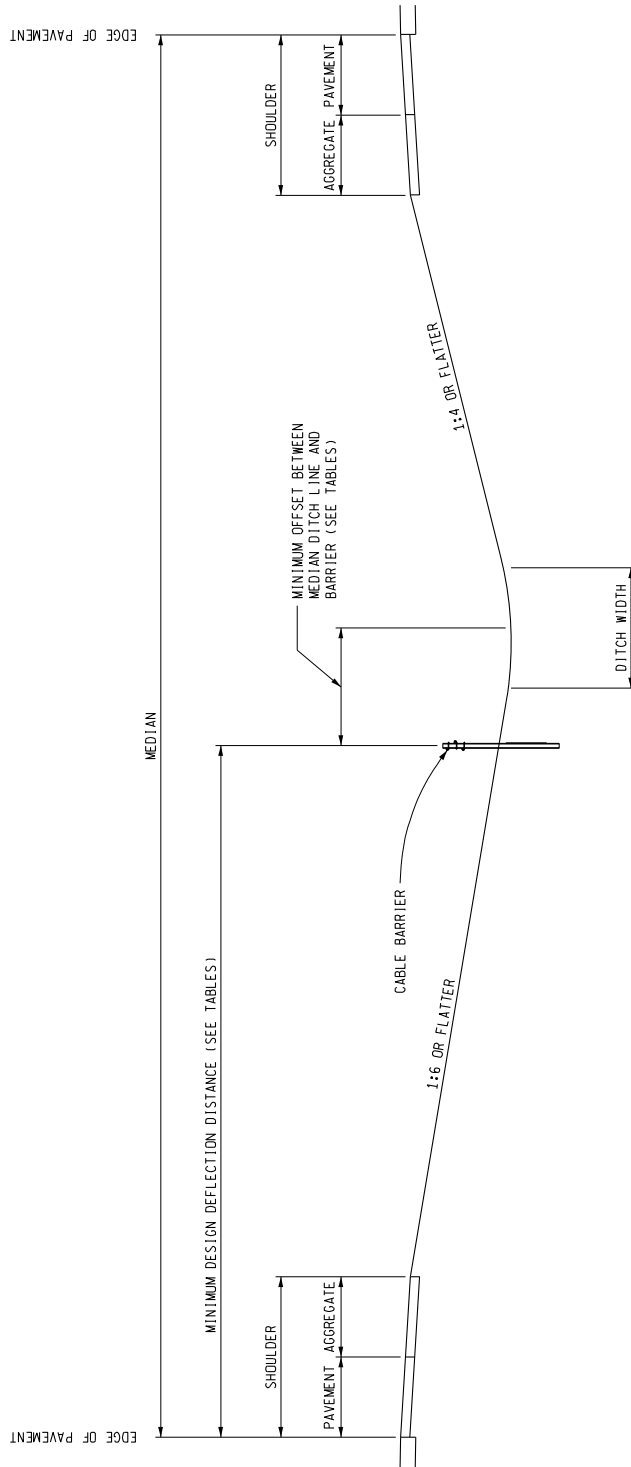

MEDIAN SLOPES 1:6 OR FLATTER ON ONE SIDE AND STEEPER THAN 1:6 ON THE OTHER
LOW TENSION CABLE BARRIER OR HIGH TENSION SYSTEMS RATED FOR 1:6 SLOPES OR FLATTER

ROAD DESIGN MANUAL ROAD DESIGN

7.01.55C (continued)

Median Barrier Types

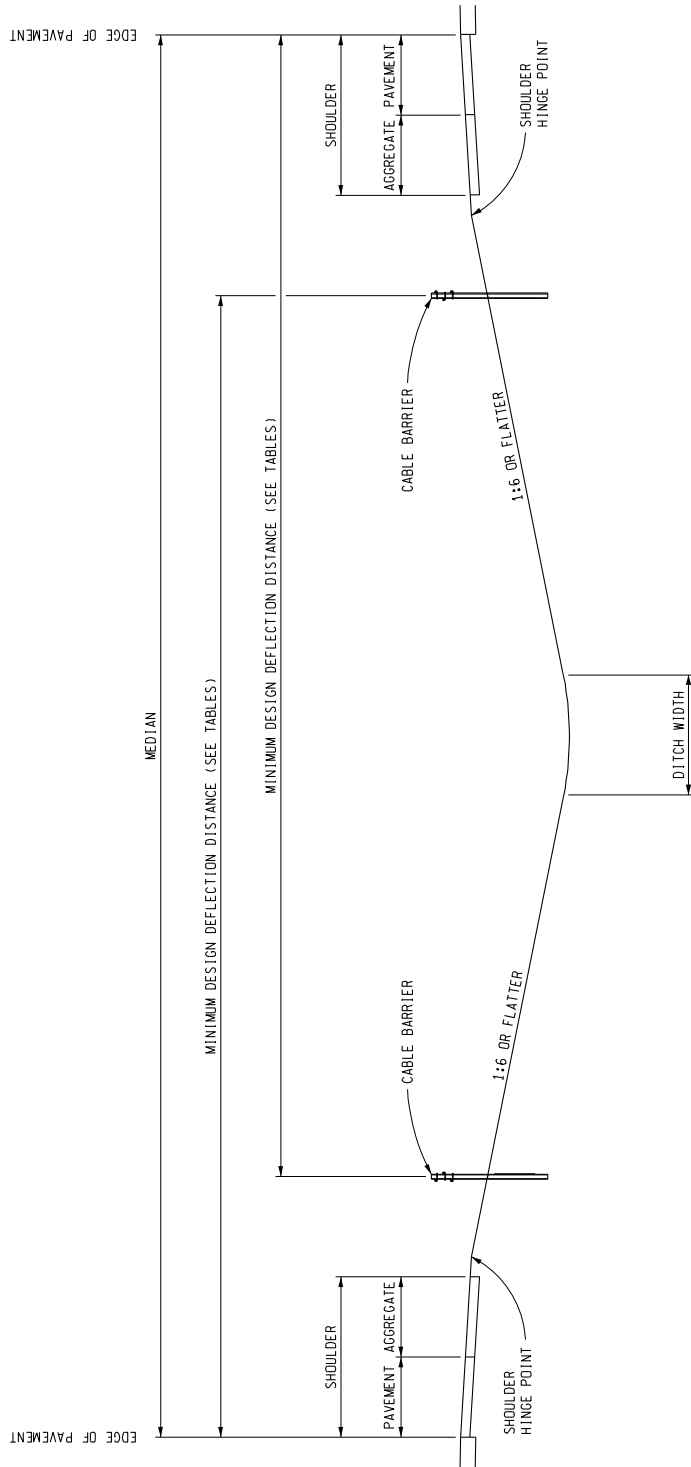

DUAL RUNS ON MEDIAN SLOPES 1:6 OR FLATTER

ROAD DESIGN MANUAL ROAD DESIGN

7.01.55C (continued)

Median Barrier Types

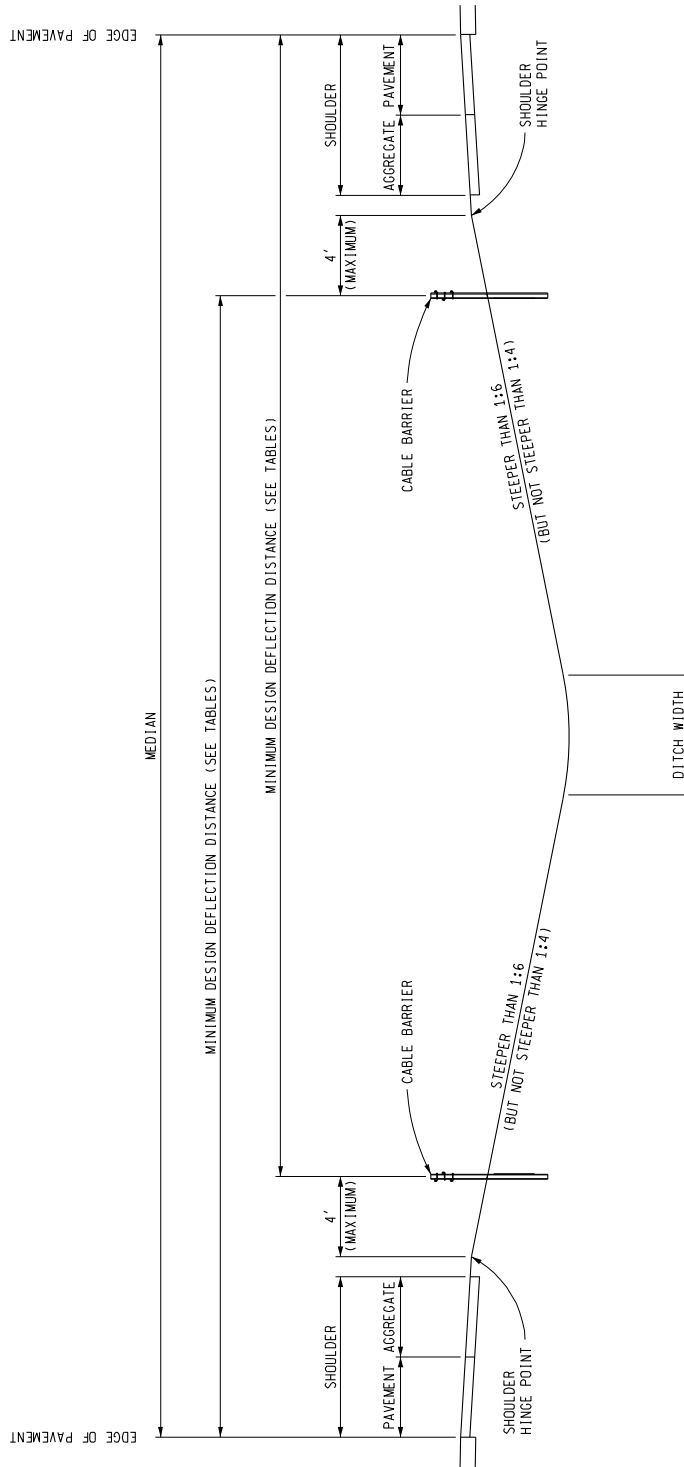

DUAL RUNS ON MEDIAN SLOPES STEEPER THAN 1:6 UP TO 1:4
FOR CABLE SYSTEMS RATED FOR INSTALLATION ON 1:4 SLOPES

ROAD DESIGN MANUAL ROAD DESIGN

7.01.55C (continued)

Median Barrier Types

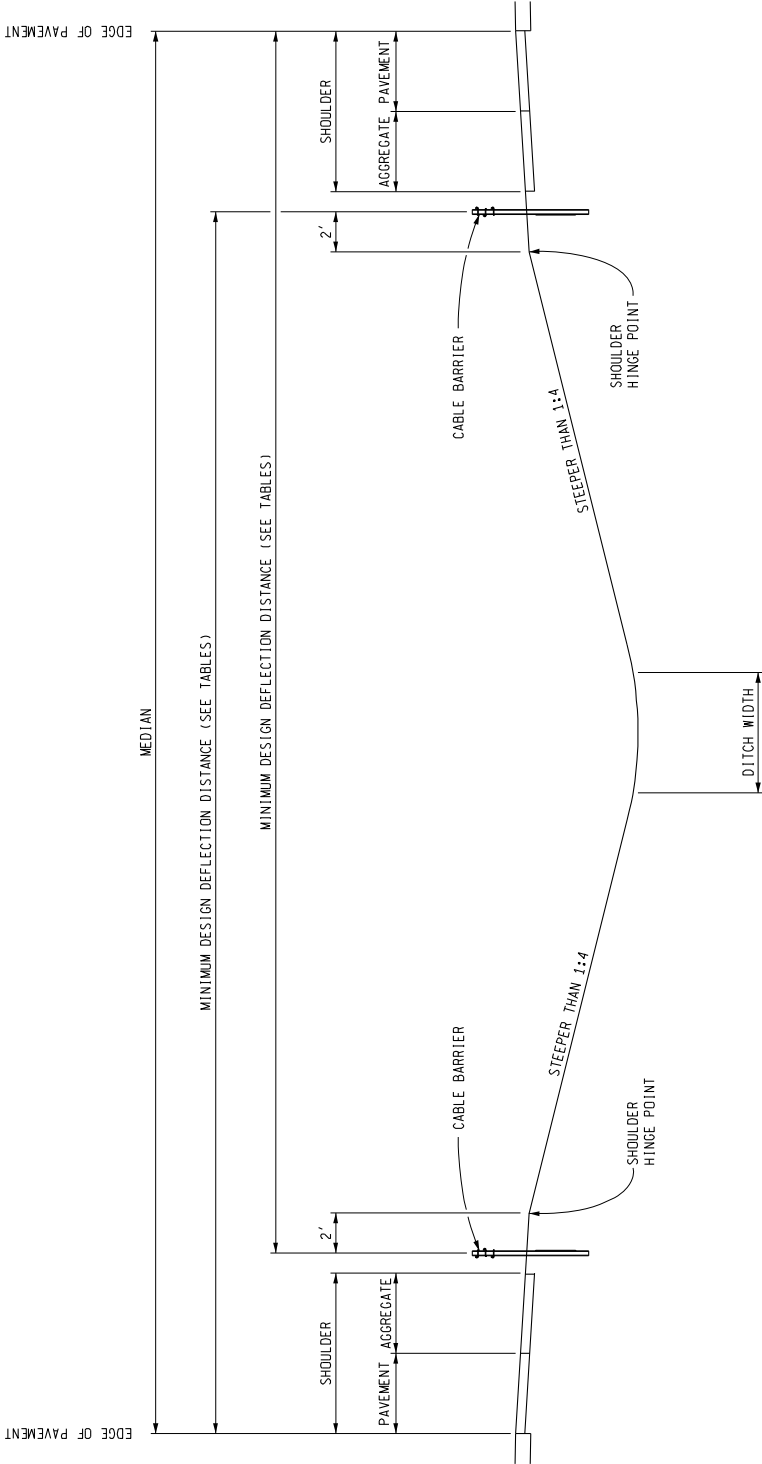

MEDIAN SLOPES STEEPER THAN 1:4

ROAD DESIGN MANUAL
ROAD DESIGN

7.01.55C (continued)

Median Barrier Types

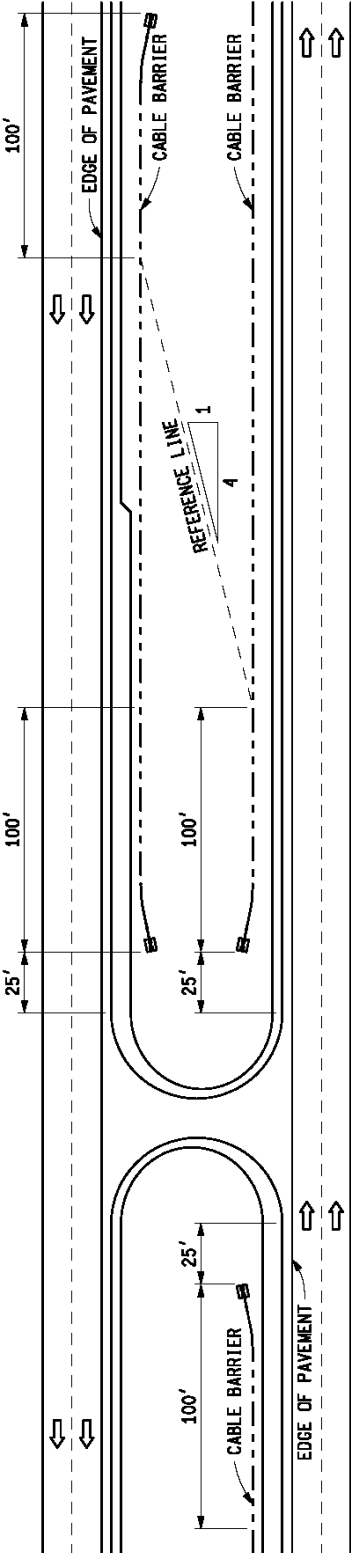

MAINTENANCE CROSSOVER LAYOUT

ROAD DESIGN MANUAL ROAD DESIGN

7.01.55C (continued)

Median Barrier Types

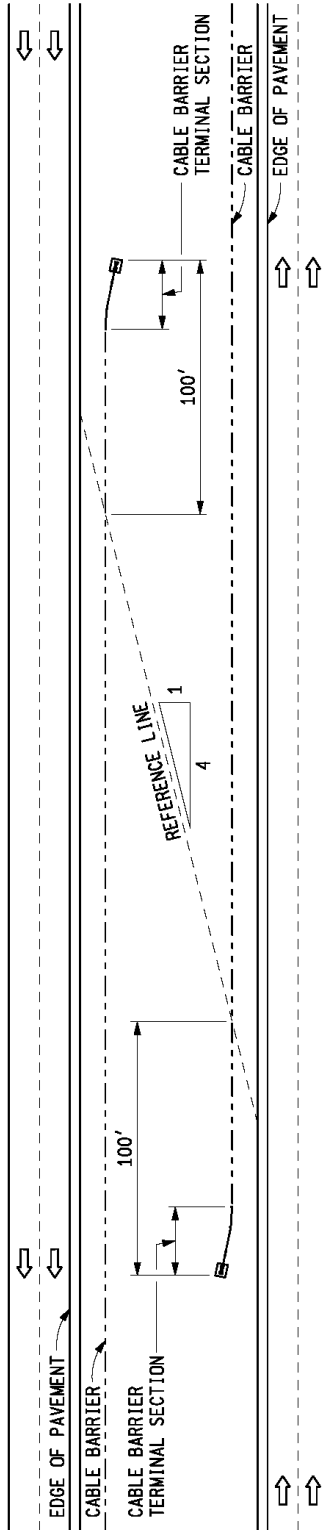

CABLE BARRIER SHIFT - APPROACH END

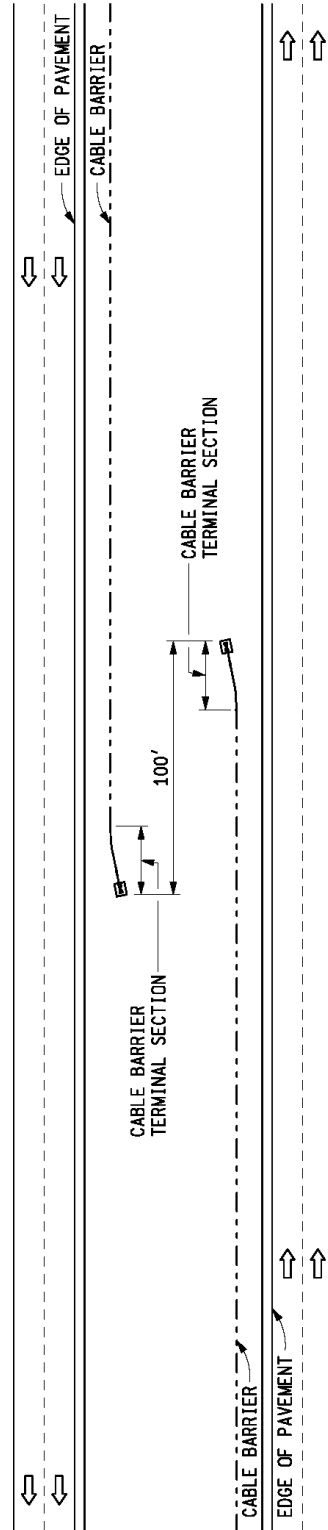

CABLE BARRIER SHIFT - DEPARTING END

ROAD DESIGN MANUAL ROAD DESIGN

7.01.55C (continued)

Median Barrier Types

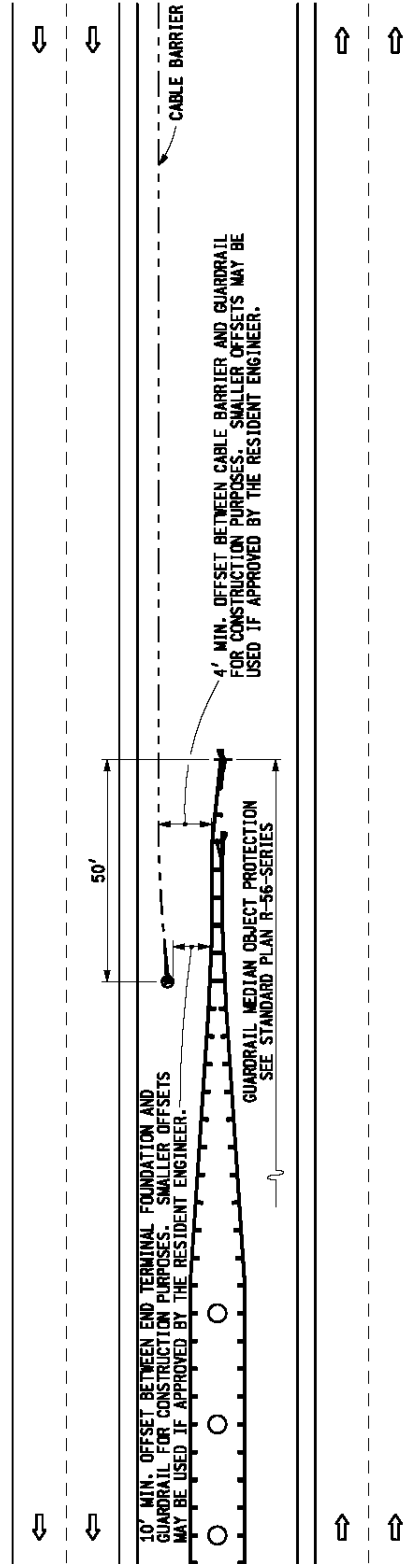
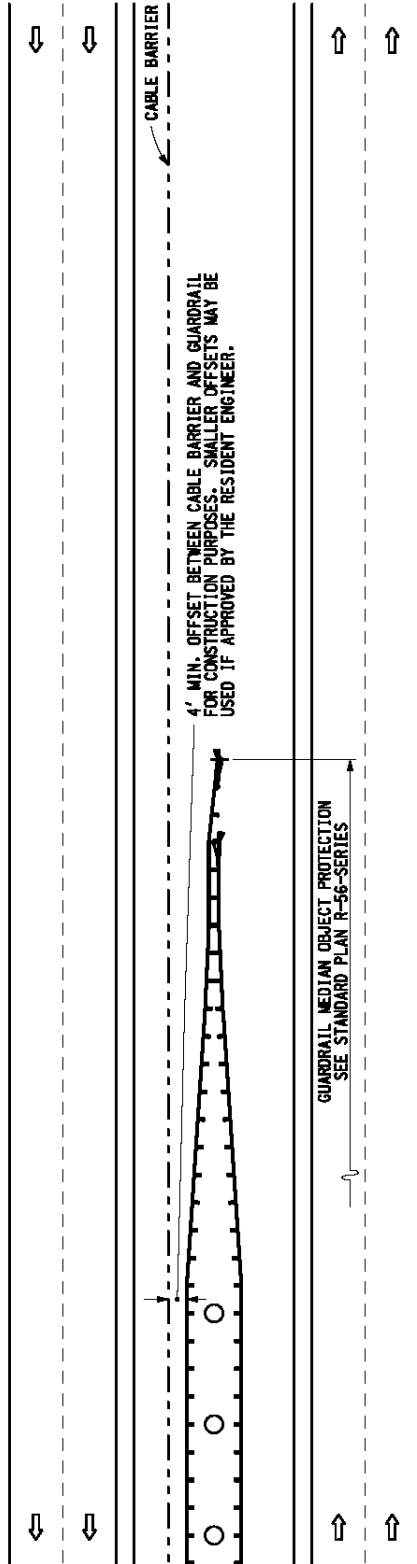

CABLE BARRIER AT BRIDGE PIERS PROTECTED BY GUARDRAIL

ROAD DESIGN MANUAL ROAD DESIGN

7.01.55C (continued)

Median Barrier Types

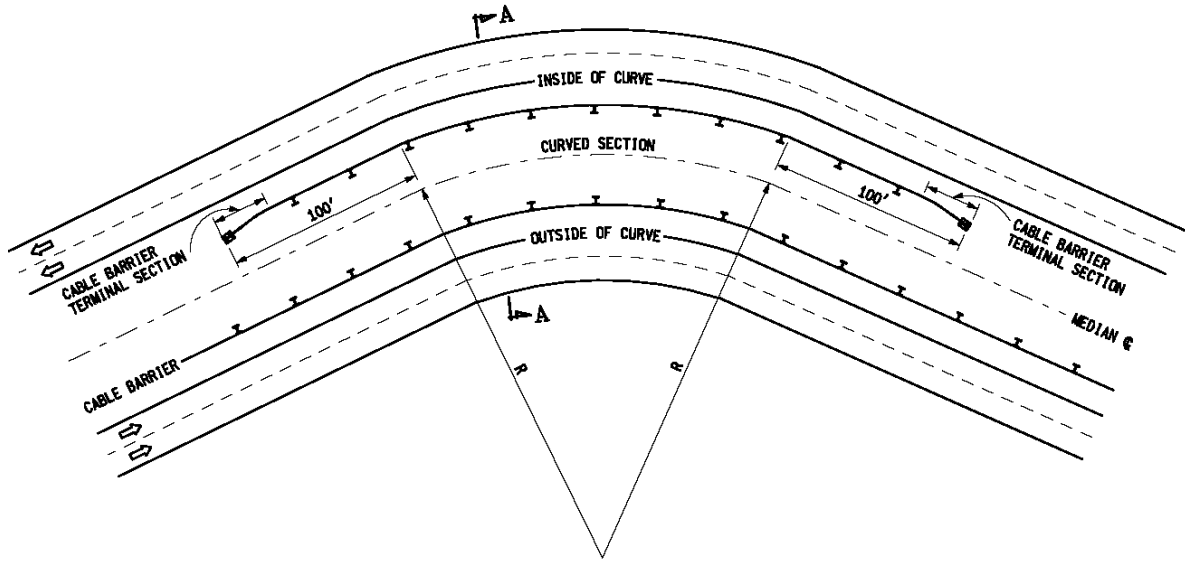

OPTION #1 *

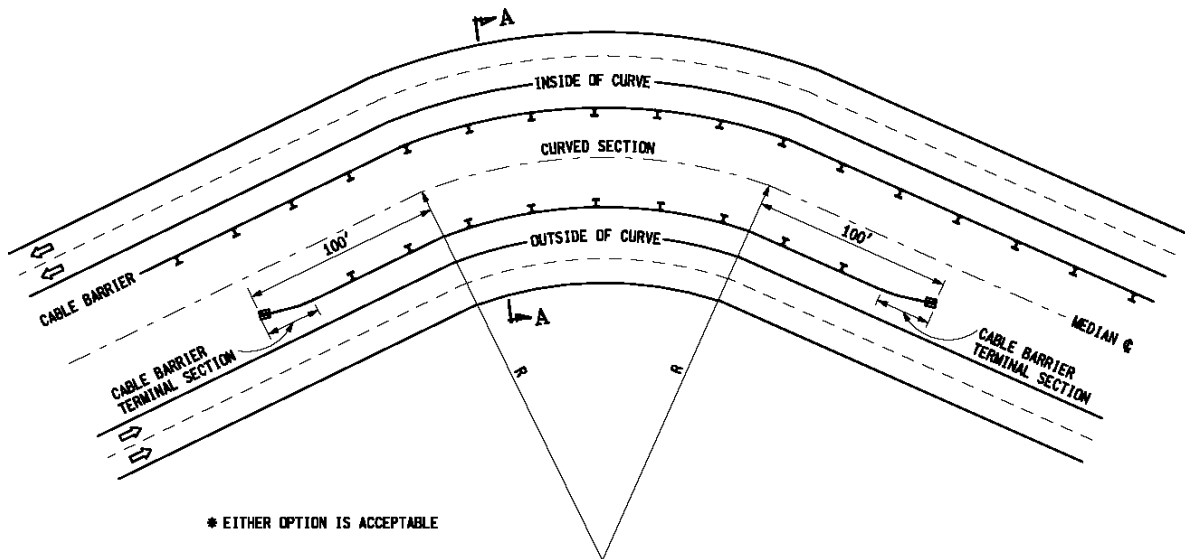

OPTION #2 *

HEIGHT DIFFERENCE
(SEE GEOMETRIC DESIGN UNIT OF THE DESIGN
DIVISION FOR GUIDANCE ON HEIGHT DIFFERENCE)

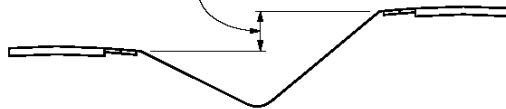

SECTION A-A

RECOMMENDED CABLE BARRIER PLACEMENT ON CURVED ROADWAYS

$R < 5,730'$ WITH UNEQUAL EMBANKMENT HEIGHT OR MEDIAN SLOPES STEEPER THAN 1:4

ROAD DESIGN MANUAL ROAD DESIGN

7.01.55C (continued)

Median Barrier Types

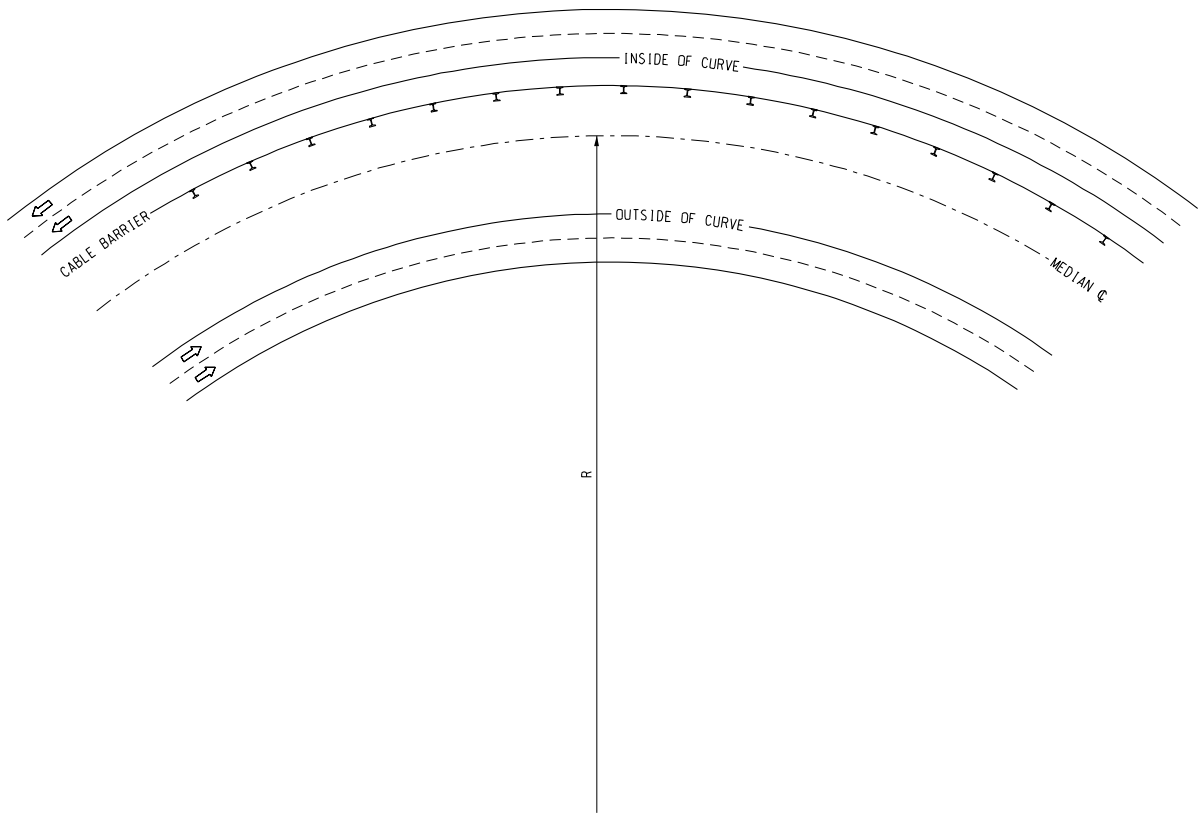

RECOMMENDED CABLE BARRIER PLACEMENT ON CURVED ROADWAYS

$5,730' \leq R \leq 11,460'$
 $R < 5,730'$ WITH EQUAL EMBANKMENT HEIGHT AND 1:4 OR FLATTER MEDIAN SLOPES

ROAD DESIGN MANUAL ROAD DESIGN

7.01.56 (revised 4-24-2023)

7.01.56 (continued)

Concrete Median Barriers

A. GM Shape

The first concrete barrier shape used in Michigan was developed by General Motors. Sections of the GM barrier shape still remain in use, but is no longer being built on new construction projects. It was replaced by the New Jersey shape on Standard Plan II-49D in 1976.

The key design parameter for a safety shape barrier is the distance from the ground to the slope break point because this determines how much the vehicle suspension will be compressed. The higher slope break (1'-1") of the GM shape causes less sheet metal damage, but it has more potential for an impacting vehicle to ride up on the barrier. There would be nothing wrong with a vertical-faced barrier except that the slightest vehicle contact will result in sheet metal damage. A vertical wall, of course, is more difficult to construct if slip-form methods are used.

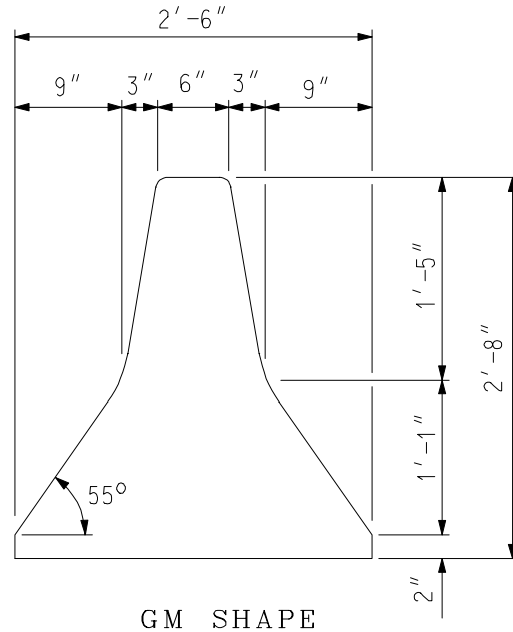

At it's June 2, 2000 meeting, the Engineering Operations Committee approved a Department policy that calls for replacement of existing GM barrier as warranted by the condition of the existing barrier and crash history.

B. New Jersey Shape

The New Jersey shape was the second barrier shape used in Michigan. It has a 3" high vertical face at the toe. This is an allowance for future resurfacing. The 10" radius at the change in vertical slope has no safety purpose; it is for aesthetic purposes only. The standard 10" top width was determined as necessary to provide the same overturning moment as the previously used G.M. barrier, and to reduce the probability of fracture under heavy impact. It should be emphasized that the New Jersey shaped barrier should not be built with a 6" top width and, in fact, has never been standard in Michigan.

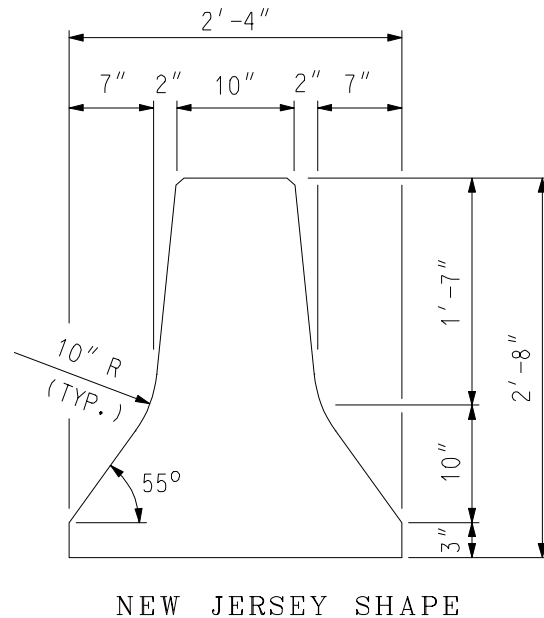

ROAD DESIGN MANUAL

ROAD DESIGN

7.01.56 (continued)

Concrete Median Barriers

C. Single Slope

The single slope is Michigan's current standard shape. It has a 32" base and a 16" top which are connected by single 21:4 slopes on each side of the barrier. This single slope design provides the potential for several future overlays, since the single slope shape will not be impacted by future overlays. However, designers must ensure that the barrier is at least 36" tall after an overlay in order to meet the minimum barrier height requirement for MASH, TL-4 conditions.

The single slope is also common to a majority of the states in the country and is easier to slip form than the New Jersey shape.

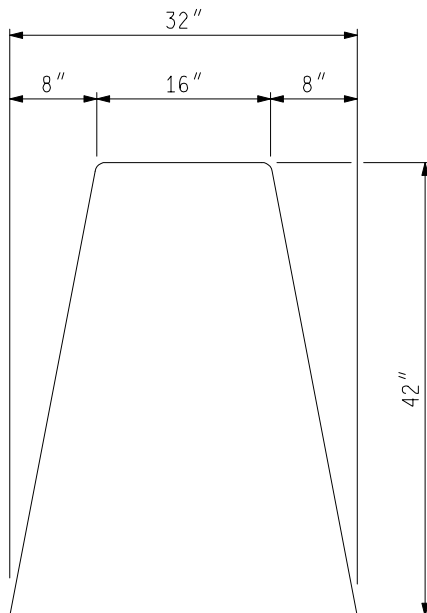

SINGLE SLOPE

7.01.57 (revised 4-24-2023)

Ending Concrete Barrier

Concrete barrier normally can be ended by attaching a combination of a bridge guardrail anchorage (Standard Plan R-67-Series), conventional guardrail, and a guardrail approach terminal (see Standard Plans R-61 & R-62-Series). The same criteria for calculating the length of need should be used with the concrete barrier included in the length of need. The minimum length of anchorage and ending guardrail are specified on Standard Plan R-54-Series.

In the case of ending a concrete median barrier, the approach side can be ended with guardrail as long as the barrier is ended with all portions of the barrier system being located outside the clear zone area for the opposing traffic.

Where the minimum length and lateral clearance cannot be obtained, a more expensive alternative for ending the concrete barrier would be to use an impact attenuator. (See [Section 7.02.](#))

ROAD DESIGN MANUAL ROAD DESIGN

7.01.58 (revised 4-24-2023)

Two Types of Concrete Median Barrier Footings

Designers should note that the standard plan for concrete median barrier (R-49-Series) specifies a Type A and a Type B. Type A has an integrally cast footing whereas Type B is doweled to a separately cast footing or concrete shoulder. When Type A barrier is called for on the plans the contractor has the option of casting the base integrally with footing or constructing the barrier in the same manner as Type B without any extra payment. Type B is payment for the upper portion of the barrier and is doweled onto an existing separately cast footing or concrete shoulder. If the designer wants to designate that the barrier be cast on a separate footing, they should note this on the plans or in a special provision.

7.01.59 (revised 10-22-99)

Concrete Glare Screen

Concrete glare screen, as opposed to glare screen made of other materials, is now used exclusively in Michigan when a glare screen is needed in conjunction with a concrete median barrier. Glare screen is called for routinely whenever the concrete median barrier is on a curve and whenever the concrete median barrier is used on new urban type construction. See [Section 7.03](#).

7.01.60 (revised 4-24-2023)

Retrofitting Concrete Median Barrier

It is usually difficult and costly constructing a concrete median barrier where no median barrier had existed previously and especially where the median is drained by open ditch. Factors which the designer must consider are:

1. Where will the median barrier be placed? If located at the center of the median, the clear recovery area remaining is equal for both roadways; if constructed adjacent to one shoulder, recovery area is unequal for the two directions.

7.01.60 (continued)

2. Is the median ditch shallow enough and the slopes gentle enough to permit safe traversal? Typically slopes leading to the face of concrete barriers should be 1:10 or flatter. If the open ditch must be filled in and enclosed drainage provided, then the median must be completely reconstructed.
3. If enclosed drainage is decided upon, are roadway grades sufficient to drain surface water?

When flat (0 - 0.1%) grades are encountered, it may be necessary to use metal slotted drain adjacent to concrete median barrier. When slotted drain is used, only about 50% of the length of flat grade actually needs the slotted drain (placed intermittently).

7.01.65 (revised 5-22-2017)

Concrete Median Barrier Between Roadways of Different Elevations

Superelevation on divided highways may cause the median shoulders to be at different elevations. When this occurs, one side will be higher than normal resulting in the median barrier being asymmetrical. The barrier must be specially detailed on the plans. The single slope shape should be used, and the high side should be created by extending the upper slope as high as necessary to match the other, normal, side. The plans should not refer to the single slope shape as such, except in the context that it is modified.

A 2'-0" difference in elevation is the maximum the barrier can accommodate without the use of steel reinforcement. Elevation differences exceeding 2'-0" will require structural steel reinforcement in the barrier, and slip-forming should not be permitted when constructing reinforced barrier sections. Contact the Geometric Design Unit, Design Division for assistance with designing barriers with a grade separation exceeding 2'-0".

ROAD DESIGN MANUAL ROAD DESIGN

7.01.65 (continued)

Concrete Median Barrier Between Roadways of Different Elevations

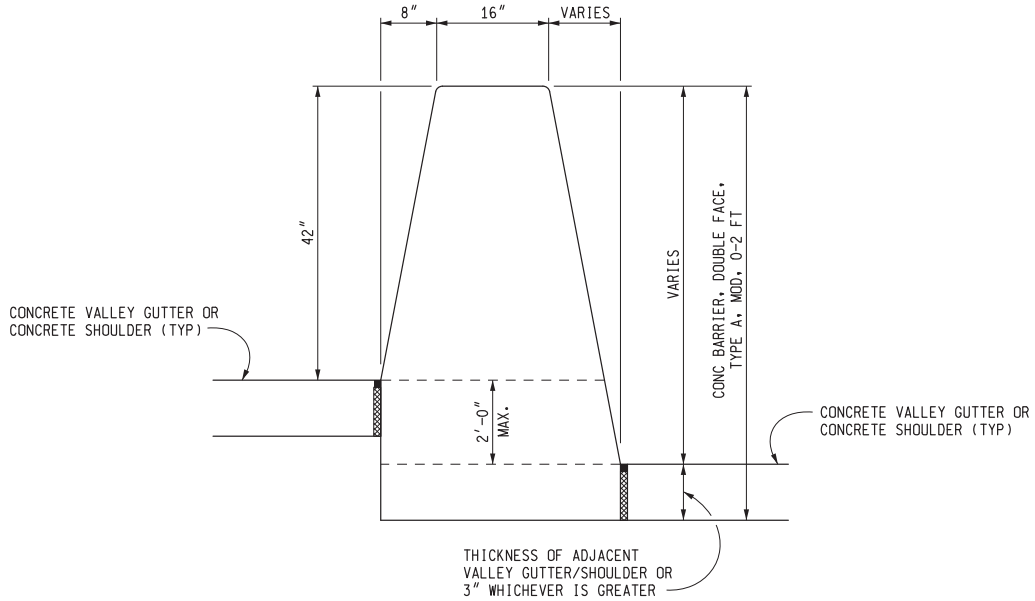

CONCRETE BARRIER, TYPE A
WITH
HEIGHT DIFFERENCE BETWEEN MEDIAN SHOULDERS
(2'-0" MAXIMUM)

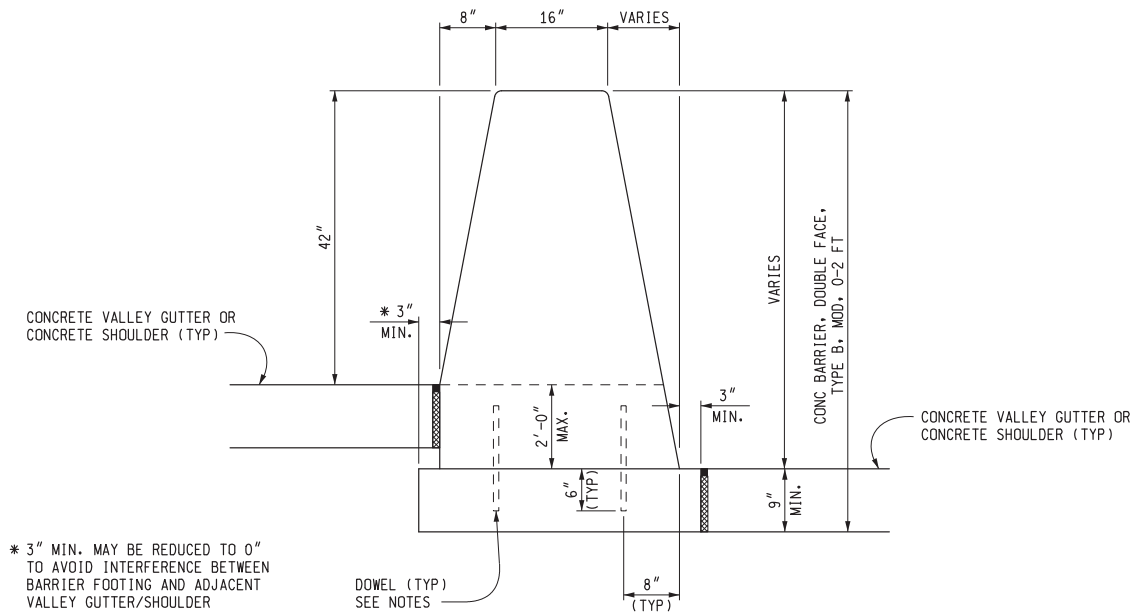

CONCRETE BARRIER, TYPE B
WITH
HEIGHT DIFFERENCE BETWEEN MEDIAN SHOULDERS
(2'-0" MAXIMUM)

ROAD DESIGN MANUAL ROAD DESIGN

7.01.66 (revised 4-24-2023)

Concrete Barrier, Single Face

Single face concrete barrier was developed to shield roadside objects or features from one side only. One such situation is found on depressed expressways, where the right-side approaches to bridge piers need shielding from only one side. The Metro Region favors the use of a concrete barrier over the use of steel beam guardrail in these locations. The major justification for its use is minimal maintenance. The results are less exposure to risk for maintenance personnel and the reduced potential of a damaged system being exposed to the motoring public between an impact and the completed repair.

If the normal width shoulder can be maintained and a concrete barrier is needed, it should be placed in front of the underpass bridge piers. Otherwise, the concrete barrier should be transitioned to the vertical face of the pier column as specified on Standard Plan R-54-Series. Because single face concrete barrier is most commonly used on urban depressed expressways, the approach ending is usually buried in the adjacent cut slope. See Standard Plan R-54-Series. If the approach end cannot be buried in a backslope, it should be shielded with a minimum of a Guardrail Anchorage, Bridge and a guardrail approach terminal, or an impact attenuator.

The use of single face concrete barrier will usually be requested at the plan review meeting and will usually be restricted to the depressed urban freeway situation. Its use in rural areas is generally discouraged because of the cost factor, the "snow fence" effect, and drainage problems created by concentrating runoff at one or few locations on high fills. However, the single face concrete barriers might be considered between two consecutive bridges having concrete railings that are approximately 200' apart or less.

7.01.67 (revised 4-24-2023)

Temporary Barrier

Temporary barrier was introduced in Michigan around 1972, with temporary concrete barrier being the first type of temporary barrier available. Since that time, the use of temporary barrier in construction work zones has steadily increased. Temporary barrier serves a dual purpose: it shields hazards originating from construction practices and protects construction and maintenance personnel from the inherent hazard of closely adjacent moving traffic.

Presently, three crashworthy temporary barrier types are available for use; temporary concrete barrier, temporary steel barrier, and portable water-filled barrier. Each temporary barrier type has unique features and limitations. Therefore, it is important to determine which barrier types are acceptable for use on each project based on site-specific conditions.

A. Temporary Concrete Barrier (TCB)

TCB sections were initially precast. Then, a cast-in-place or slip-formed barrier similar to permanent barrier was allowed. Current designs meeting or exceeding NCHRP 350, TL-3 or MASH, TL-3 criteria are now required. TCB is the most commonly used temporary barrier type on Michigan roadways.

ROAD DESIGN MANUAL ROAD DESIGN

7.01.67 (continued)

B. Temporary Steel Barrier (TSB)

TSB sections are fabricated entirely of galvanized steel. Each TSB manufacturer has a unique design with a specific brand name assigned to each design. TSB used by the Department must meet or exceed NCHRP 350, TL-3 or MASH, TL-3 criteria and have FHWA acceptance.

TSB is typically much lighter than TCB. As a result, TSB is typically easier to transport, install, and disassemble compared to TCB. Various TSB designs are available with tested impact deflections and performance characteristics comparable to TCB. However, the purchase cost of TSB is typically more than TCB.

Some TSB manufacturers can provide TSB sections equipped with casters for ease of movement on paved surfaces. Casters on TSB sections are retractable, raised or lowered, either by a hand crank or compressed air mechanism. When the casters are raised, the bottom of the TSB section comes in contact with the underlying pavement and functions as a standard TSB section. When the casters are lowered, the casters allow the TSB section to be maneuvered in any direction. Casters and their respective mechanisms are located within TSB sections, and are typically installed at the manufacturing facility during fabrication of TSB sections.

Some TSB designs require the pinning of TSB sections to the underlying pavement. Generally, TSB pins can be easily removed and the resulting holes in the pavement are filled with epoxy.

7.01.67 (continued)

C. Portable Water Filled Barrier

Portable water filled barrier consists of plastic sections, alternating white and work zone safety orange for high visibility, that are filled with water after the sections have been assembled. Portable water-filled barrier used by the Department must meet or exceed NCHRP 350, TL-3 or MASH, TL-3 criteria and have FHWA acceptance.

When empty, portable water filled barrier sections are the lightest of all temporary barrier types. Consequently, they are relatively easy to transport, install, and disassemble. Due to their light weight, cranes or heavy equipment typically are not needed to install and disassemble empty barrier sections. The process of filling the barrier sections with water and emptying them is also simple and efficient.

Portable water filled barrier may be used year round, provided that manufacturer-approved and Department compliant anti-freeze agents are used in the appropriate doses to prevent the water from freezing inside the barrier sections.

The use of portable water filled barrier is very limited due to excessive impact deflection. Crash tests have shown that portable water-filled barrier designs typically deflect more than TCB or TSB when impacted. One specific portable water-filled barrier system deflected over 22 feet, laterally, when subjected to NCHRP 350, TL-3 crash testing.

Portable water filled barrier should only be used in cases where sufficient space is available for the barrier to deflect when impacted while providing adequate work zone protection.

ROAD DESIGN MANUAL ROAD DESIGN

7.01.67 (continued)

D. Temporary Barrier Quantities and Specifications

When computing quantities of temporary barrier, the designer should review the staging plans and determine the maximum length of each barrier type required at any one time on the project.

Contact the Geometric Design Unit (Design Division) for current specifications and special provisions regarding temporary barrier.

1. Temporary Concrete Barrier (TCB) and Temporary Steel Barrier (TSB)

On most projects, standard TSB may be used as an alternative to standard TCB, and the Contractor may be given the choice of furnishing TCB or TSB. The option of furnishing standard TSB as an alternative to standard TCB can be provided by special provision without the use of a separate pay item. However, if TSB equipped with casters is required, a separate special provision and pay item is needed for furnishing TSB equipped with casters.

Standard pay items should be used for operating, adjusting, and relocating standard TCB or TSB, since the same pay items apply to both standard TCB and standard TSB.

Note that different pay items and special provisions are used for standard temporary barrier and limited deflection temporary barrier (furnishing, operating, adjusting, and relocating).

7.01.67D (continued)

2. Portable Water Filled Barrier

The pay item "Portable Water Filled Barrier, Furn" is used for furnishing portable water filled barrier.

The pay item "Portable Water Filled Barrier, Oper" is used for operating, maintaining, cleaning, relocating, filling/emptying the barrier sections, and removal of portable water filled barrier.

Please note that additional pay items and quantities typically are not used for adjusting or relocating portable water filled barrier. Any costs associated with adjusting or relocating portable water filled barrier are included as part of the "Portable Water Filled Barrier, Oper" pay item, and are not paid for separately.

ROAD DESIGN MANUAL ROAD DESIGN

7.01.68 (revised 4-24-2023)

Ending Temporary Barrier

A. Temporary Concrete Barrier and Temporary Steel Barrier

The methods for ending temporary concrete barrier and temporary steel barrier are specified on Standard Plan R-126 Series.

B. Portable Water Filled Barrier

When the barrier ending is located within the clear zone, a crashworthy end treatment that is compatible with the portable water filled barrier must be installed. The crashworthy end treatment must meet or exceed the requirements of NCHRP 350, TL-3 or MASH, TL-3.

Some portable water filled barriers are designed such that the barrier itself is a crashworthy end treatment. In which case, when the barrier ending is located within the clear zone, a separate crashworthy end treatment is not required.

Payment for furnishing, operating, and relocating crashworthy end treatments for portable water filled barrier endings is included as part of the "Portable Water Filled Barrier, Furn" and "Portable Water Filled Barrier, Oper" pay items, and is not paid for separately.

7.01.69 (revised 4-23-2012)

Temporary Barrier at Bridge Deck and Railing Reconstruction

Temporary barrier is frequently used on bridge railing replacement projects. Its use, however, is not feasible if it results in lane widths of less than 10'-0", nor if the duration of need is short. In the latter event, alternatives are plastic drums, traffic signals at each end of the work site, or a detour. It may be noted that use of barrier on a bridge produces three points of constriction at about the same location: a narrower shoulder, introduction of the bridge railing, and the funneling down created by the barrier itself. If possible, it is better if these constrictions and driver decision points can be spread out along the approach roadway.

Bridge deck reconstruction usually requires more work area than bridge railing reconstruction, and will frequently result in bi-directional traffic control on a single lane. Temporary barrier is commonly used in this application and a detail showing placement is specified on Standard Plan R-126-Series. Maintaining traffic provisions should be included in the plans.

ROAD DESIGN MANUAL ROAD DESIGN

7.01.70 (revised 11-23-2015)

Temporary Barrier Adjacent to a Precipitous Drop-off

There are occasions, notably when reconstructing a bridge by part width, when maintaining traffic constraints will force the placement of temporary barrier immediately adjacent to a precipitous drop-off situation. This creates a potential for the line of barrier to be displaced under impact, when there may be inadequate room available for displacement. When this condition occurs, special barrier types and/or hardware are needed to ensure that the barrier will function properly.

Standard temporary barrier is usually adequate when the lateral offset between the toe of the barrier on the construction side and the drop-off is 26" or greater. However, when there is less than 26" laterally between the toe of the barrier on the construction side and the drop-off, limited deflection temporary barrier meeting the requirements of Standard Plan R-53-Series or an approved alternative is required.

If designers reference barrier offset from the toe of the barrier on the *traffic* side to the drop off, then limited deflection temporary concrete barrier should be specified for offsets less than 4'-6", as opposed to the "A" distance specified in Standard Plan R-53-Series. This is required since current MDOT specifications allow a wide variety of standard temporary barriers to be used, and the bottom width of standard temporary barrier can be as wide as 28". Therefore, when referencing barrier offset from the toe of the barrier on the *traffic* side to the drop-off, the 4'-6" minimum offset for standard temporary barrier would ensure that the "A" distance specified in Standard Plan R-53-Series is at least 26" with any standard temporary barrier permitted under current MDOT specifications.

7.01.70 (continued)

Note that any alternatives to Standard Plan R-53-Series must meet current crash testing criteria and must also be adequate for installation at each location taking site-specific features and constraints into consideration, including, but not limited to, proposed barrier offset from the drop-off, underlying surface type, and expansion joints in the underlying surface. In general, portable water filled barrier should not be placed adjacent to or near a precipitous drop-off, unless there is sufficient room between the barrier and the drop-off for the barrier to deflect during an impact.

When using limited deflection temporary barrier meeting Standard Plan R-53-Series, designers will need to select the appropriate detail for use at each location. Designers will need to determine the proposed offset between the barrier and the drop-off at each location, and the underlying surface type and condition at each location. In addition, when placing limited deflection temporary barrier over a bridge deck, designers may need to determine the number of expansion joints in the bridge deck, and the amount of thermal expansion/contraction expected at each joint.

ROAD DESIGN MANUAL ROAD DESIGN

7.01.70 (continued)

A. Detail 1, Standard Plan R-53-Series: Box Beam Stiffened Method

Of all the details in Standard Plan R-53-Series, Detail 1 requires the least amount of pinning to the underlying surface. With Detail 1, pinning to the underlying surface is only required to secure the ends of the limited deflection temporary barrier, as shown in Standard Plan R-53-Series. Therefore, Detail 1 is desirable in cases where pinning the barrier to the underlying surface needs to be minimized to reduce the possibility of damaging the underlying surface. For example, placing limited deflection temporary barrier over a new bridge deck or an existing bridge deck that will be left in place after construction.

When using Detail 1 on bridge decks, designers should extend the limited deflection temporary barrier beyond the limits of the bridge deck to ensure that all required pinning to the underlying surface occurs off the bridge deck.

Detail 1 may be placed over all bridge deck expansion joints, regardless of the number of joints in the deck or the amount of thermal expansion/contraction expected at each joint.

A minimum offset of 12" between the toe of the barrier on the construction side and the drop-off must be provided when using Detail 1. Other details must be considered if a minimum 12" offset cannot be provided.

7.01.70 (continued)

B. Detail 2, Standard Plan R-53-Series: Staked Method

Detail 2 should be considered when a limited deflection temporary barrier is required over an HMA roadway, and the barrier must be placed less than 12" from the toe of the barrier on the construction side to the drop-off. Note that a minimum barrier offset of 6", between the toe of the barrier on the construction side and the drop-off, must be provided in order to use Detail 2.

Since Detail 2 requires the use of 3'-4" long stakes that extend considerably into the ground, designers should examine the proposed installation site and verify that underground utilities or obstructions will not be impacted by the stakes. Designers may need to relocate the barrier and/or consider other options if underground utilities or obstructions are going to be impacted by Detail 2.

ROAD DESIGN MANUAL ROAD DESIGN

7.01.70 (continued)

C. Detail 3A, Standard Plan R-53 Series: Through Bolt Method on Concrete Bridge Deck

Detail 3A should be considered when a limited deflection temporary barrier is required over a concrete bridge deck, and the barrier must be placed less than 12" from the toe of the barrier on the construction side to the drop-off. With Detail 3A, the toe of the barrier on the construction side can be placed up to the edge of the drop-off, but must not be placed beyond the edge of the drop-off.

In general, Detail 3A is preferred over Detail 4A (Drilled and Grouted Method) on concrete bridge decks. However, designers must avoid using Detail 3A on bridge decks with corrugated metal decking, since the metal decking will present difficulties with anchor bolt installation.

Detail 3A must not be used on concrete bridge decks with an HMA overlay, since the anchor bolts in Detail 3A lack the additional reinforcement needed to withstand higher bending moments induced during an impact in the anchor bolts at the top of the concrete surface.

Since drilling through bridge decks may be undesirable or prohibited on some bridges, designers should consult with the Technical Section of Bridge Field Services before using Detail 3A.

7.01.70 (continued)

D. Detail 3B, Standard Plan R-53-Series: Through Bolt Method on Concrete Bridge Deck with an HMA Overlay

Detail 3B should be considered when a limited deflection temporary barrier is required over a concrete bridge deck with an HMA overlay, and the barrier must be placed less than 12" from the toe of the barrier on the construction side to the drop-off. With Detail 3B, the toe of the barrier on the construction side can be placed up to the edge of the drop-off, but must not be placed beyond the edge of the drop-off.

Detail 3B is required when an HMA overlay is present over a concrete bridge deck, since a steel tube is needed around each anchor bolt for additional reinforcement due to higher bending moments induced during an impact in the anchor bolt at the top of the concrete surface. This is the reason why Detail 3A must not be used on concrete bridge decks with an HMA overlay.

Designers must avoid using Detail 3B on bridge decks with corrugated metal decking, since the metal decking will present difficulties with anchor bolt installation.

Since drilling through bridge decks may be undesirable or prohibited on some bridges, designers should consult with the Technical Section of Bridge Field Services before using Detail 3B.

ROAD DESIGN MANUAL ROAD DESIGN

7.01.70 (continued)

E. Detail 4A, Standard Plan R-53-Series: Drilled and Grouted Method on Concrete Roadway or Concrete Bridge Deck

Detail 4A should be considered when a limited deflection temporary barrier is required over a concrete roadway or concrete bridge deck, and the barrier must be placed less than 12" from the toe of the barrier on the construction side to the drop-off. With Detail 4A, the toe of the barrier on the construction side can be placed up to the edge of the drop-off, but must not be placed beyond the edge of the drop-off.

Designers may consider using Detail 4A on concrete bridge decks with corrugated bridge decking. However, Detail 4A cannot be used on concrete bridge decks with an HMA overlay.

Since drilling through bridge decks may be undesirable or prohibited on some bridges, designers should consult with the Technical Section of Bridge Field Services before using Detail 4A on a bridge deck.

F. Detail 4B, Standard Plan R-53-Series: Drilled and Grouted Method on Concrete Roadways with an HMA Overlay

Detail 4B should be considered when a limited deflection temporary barrier is required over a concrete roadway with an HMA overlay, and the barrier must be placed less than 12" from the toe of the barrier on the construction side to the drop-off. With Detail 4A, the toe of the barrier on the construction side can be placed up to the edge of the drop-off, but must not be placed beyond the edge of the drop-off.

Detail 4B is intended for exclusive use on concrete roadways with an HMA overlay, and cannot be used on bridge decks.

7.01.70 (continued)

G. Placing Limited Deflection Temporary Barrier Over Bridge Deck Expansion Joints

Detail 1 may be placed over all bridge deck expansion joints, regardless of the number of joints in the deck or the amount of thermal expansion/contraction expected at each joint. However, Details 3A, 3B, and 4A have certain limitations when placed over bridge deck expansion joints.

Details 3A, 3B, and 4A may be used over bridge deck expansion joints with an expected thermal expansion/contraction up to 1.5", provided the expansion joint guidelines specified in Standard Plan R-53 Series are followed during installation. No special hardware is needed with Details 3A, 3B, and 4A when the expected thermal expansion/contraction does not exceed 1.5".

Special hardware must be used when placing Details 3A, 3B, and 4A over expansion joints with an expected thermal expansion/contraction greater than 1.5", up to 4". In this case, a Type J1/J2 assembly, as shown in Standard Plan R-53 Series, must be placed over the expansion joint to accommodate the expected thermal expansion/contraction. Designers should note that a separate pay item is used for Type J1/J2 assemblies. Therefore, designers will need to include the appropriate pay item for the Type J1/J2 assembly and estimate the quantity of Type J1/J2 assemblies required on each project.

Note that Details 3A, 3B, and 4A must never be used over bridge deck expansion joints with an expected thermal expansion/contraction greater than 4".

ROAD DESIGN MANUAL ROAD DESIGN

7.01.75 (revised 5-7-2001)

Concrete Filler Walls

Concrete filler walls between pier columns serve as a continuous barrier to prevent an impacting vehicle from snagging on the pier columns. They are used when the shoulder width does not allow the approach barrier system to be carried under the structure at the normal offset from the edge of pavement. When filler walls are used, the approach barrier system, if non-rigid, should be anchored to the filler wall. See Standard Plans R-55-Series and R-67-Series.

Concrete filler walls constructed between about 1976 and 1982 were 33" high. The height was increased in June 1983 to 42" to allow for future heavy resurfacing. Some difficulty is being experienced connecting the current three beam guardrail anchorage to these older 33" high filler walls if there has been (or will be) a thick-lift resurfacing. When this occurs, provide for a filler wall extension with a minimum height of 1'-8" reinforced, and adhesive anchored to the existing filler wall with steel bars. Use horizontal sleeves in the new concrete for the guardrail attachment bolts. The approach guardrail should be aligned to allow the holes that must be drilled into the existing filler wall to be as far from the top edge as possible, to lessen the possibility of spalling during the drilling operation.

Sometimes the toe header for the bridge slope paving is behind the pier columns. This condition should be noted at the plan review meeting. When it occurs, a separate footing must be provided for the filler wall.

7.01.75 (continued)

In the past, there have been occasional attempts to cast a concrete safety shape into the filler wall in the area of the pier. This usually results in a concrete "toe" being placed, having the 55 degree slope of the safety shape, but the wall being vertical, like the conventional filler wall. It seems to work out better to simply transition the approach barrier system into the vertical face of the filler wall, and not try to cast a semblance of a safety shape that will only break away from the remainder of the structure over time.

The top of the filler wall should be constructed parallel with the grade of the road, rather than level. This gives the top lines of the approach barrier and filler wall a continuous appearance. Even though the angle between the vertical columns and the top of the filler wall will be something other than 90 degrees, its appearance will be less noticeable.

A filler wall end block shall be constructed when the connecting guardrail anchorage has one or more of the posts that can not be installed full depth. See Standard Plan R-55-Series.

ROAD DESIGN MANUAL ROAD DESIGN

7.02 (revised 4-24-2023)

IMPACT ATTENUATORS

Questions regarding impact attenuators should be directed to the Geometric Design Unit of the Design Division.

ROAD DESIGN MANUAL

ROAD DESIGN

7.03

GLARE SCREEN

7.03.01

References

- A. Standard Plan R-76-Series,
Concrete Glare Screen

7.03.02 (revised 10-22-99)

General

Glare screen was first used on median barriers within the limits of curves, where the headlight glare from vehicles rounding the curve would be momentarily aimed directly at on-coming vehicles in the opposite roadway. Various materials were tried, with expanded metal mesh finding favor in Michigan. Expanded metal mesh, while effective as a glare screen, is fragile and susceptible to damage by vehicle contact, fatigue, corrosion and wind. It thus requires almost constant maintenance. Its principal advantage is that it can be rather easily mounted on metal beam guardrail.

To overcome the shortcoming of expanded metal mesh, plastic paddles, or "Glarefoils", were developed around 1976. Varying in height from about 2'-0" to 4'-0" and made of polyethylene, they are fastened to metal brackets attached to concrete median barrier. Of hollow, oval cross-section, they are oriented at 45° to the line of barrier in such a manner that the line of sight is screened between the opposing directions of traffic, yet wind currents can pass through. Michigan's experience with plastic paddles has been mixed; they are more durable than expanded metal mesh, but they still require considerable maintenance. Plastic paddles may be considered if a temporary glare screen is required on temporary concrete median barrier, but we currently do not consider it for permanent installation.

7.03.02 (continued)

Concrete glare screen came into use in Michigan in 1973 as an "add on" to previously placed concrete median barrier. It soon became apparent that it was an economical, almost maintenance-free structure that, by comparison, ruled out further consideration of the other glare screen materials and designs. As techniques developed for slip-forming higher and almost vertical concrete walls, Standard Plan III-76D came out in 1978 requiring that, whenever glare screen was to be constructed in conjunction with a concrete median barrier, the wall must be cast monolithically, 51" high. Not only does this requirement achieve economy of construction, it lends strength and additional height to the concrete barrier as well. If concrete glare screen has a disadvantage, it is because it cannot be used in conjunction with steel beam guardrail.

7.03.03 (revised 4-24-2023)

Criterion for Use

It is current practice to place concrete glare screen on concrete median barrier whenever **new** concrete median barrier is constructed in urban areas. In rural areas the use of a glare screen will be as recommended on a project-by-project basis by the Geometric Design Unit, Design Division. (The terms "urban" and "rural" here refer to the characteristics of surrounding development, not the relationship of the project to city limit signs.)

ROAD DESIGN MANUAL ROAD DESIGN

7.04

PAVEMENT MARKINGS

7.04.01 (revised 1-19-2016)

General

Pavement markings, both permanent and temporary, are included in most trunkline projects. The inclusion of pavement markings on the remaining projects will be determined by the Region/TSC. The only type of project not required to include pavement markings (either by contract or by work order) are projects where the existing markings are not altered or obliterated.

When there are no construction projects scheduled, placement of pavement markings is accomplished through the annual Region-wide contracts.

7.04.02 (revised 10-22-2018)

Temporary Pavement Markings

See the Work Zone Safety and Mobility Manual, [Section 6.01.12](#) - Temporary Pavement Markings.

7.04.03

Section deleted.

ROAD DESIGN MANUAL ROAD DESIGN

7.04.04 (revised 10-22-2018)

Removing Permanent Pavement Markings

See the Work Zone Safety and Mobility Manual, [Section 6.01.12A](#) - Pavement Marking Removal.

7.04.05

Statutory Participating Cities

Statutory participating cities are exempt from participating in the cost of permanent pavement markings.

7.04.06 (revised 7-26-2021)

Plan Sheets, Standards Referencing, and Witness, Log, \$1,250.00

Most projects call for the placement and/or replacement of permanent pavement markings. To ensure the markings are laid out properly the Designer must include information in the plans or proposal to allow a Contractor to do so.

Markings are placed or replaced using one or a combination of the following methods:

- A log of previously witnessed markings
- Reference to standard plans (only if the standard can be placed in the field)
- Pavement marking plan sheets

When the roadway will not be geometrically or functionally altered by construction (no addition or removal of turn lanes, no change in passing and no passing zones, no addition or removal of signals, etc.) and the markings should be returned to their pre-construction configuration, marking layout can be addressed through the use of the pay item Witness, Log, \$1,250.00. Use of Witness, Log, \$1,250.00 requires the Contractor to witness and log any existing pavement markings prior to the markings or pavement being removed, and to lay the markings back out after construction. The Engineer should have the opportunity to review the pavement marking layout prior to placement and make any necessary changes, however if changes are anticipated plan sheets should be included in the project documents.

ROAD DESIGN MANUAL ROAD DESIGN

7.04.06 (continued)

While the applicable pavement marking standard plans should be listed in all contracts with markings, use of solely the standards for pavement marking establishment is only acceptable in a few situations. The standards do not address lane and shoulder widths, turn lane storage lengths, precise stop bar setbacks, and many other variables needed for marking layout, so virtually all projects should include either plan sheets or Witness, Log, \$1,250.00. Some of the exceptions to this where referencing the standards would be sufficient are bridge-specific projects (deck and/or approach work) and pavement patching projects, where the Contractor is only being asked to reconnect lines that they can see both ends of.

Plan sheets should be included if neither of the above options will adequately address the pavement marking layout needs of a project. When only a portion of a project will require changes from the existing pavement marking configuration (addition of a turn lane, correcting a section of markings that do not meet standards, etc.) it is acceptable to include plan sheets for only the portion requiring changes and utilize Witness, Log, \$1,250.00 for the remainder of the project.

7.04.07 (revised 7-26-2021)

Recessing Permanent Pavement Markings

To increase life expectancy pavement markings can be placed in a recess (groove) rather than on the pavement surface. Recessing provides protection from snowplow blades and also resistance to shearing forces from traffic passing over the markings.

All longitudinal permanent pavement markings placed with 3R/4R construction projects must be recessed, regardless of the pavement marking material used. Areas of exception are bridge decks, markings placed in a rumble strip, roadway sections that are candidates for road diets, and where markings are placed in pilot configurations (e.g. – where a road diet is installed but may be reversed). Recessing for special markings and on project types other than 3R/4R is at the discretion of the Engineer.

While recessing does aid the durability of all marking types, careful consideration must be given when recessing many styles of special markings. The groove created for the material can trap water and debris, resulting in potential hazards where motorcycles, bicycles, and pedestrians cross over the markings. As a result recessing is generally not recommended for symbols and legends, and when considering recessing for stop bars and crosswalks the Engineer should evaluate marking durability concerns against user types and volumes.

Recessed marking pay items are specified as being either longitudinal, transverse, or guide line. Recessing for lane lines, edge lines, centerlines, and gore markings falls under the longitudinal recessing pay item. All special markings, including line-style markings such as stop bars, crosswalks, and cross hatching, utilize the transverse recessing pay item. Turning guide lines (also referred to as lane line extensions, “blips”, or “chicken tracks”) have a separate recessing pay item due to the work and machinery involved.

ROAD DESIGN MANUAL ROAD DESIGN

7.04.08 (added 2-26-2018)

Longitudinal Pavement Markings in Work Zones Outside of Project Limits

Projects with long term lane closures often have traffic control devices outside of the project limits that interfere with the annual restriping of longitudinal pavement markings. Designers should include quantities in these projects for the purpose of restriping the longitudinal pavement markings outside of the project limits that are not accessible to the annual Region-wide contracts. Designers should work closely with the Region Traffic & Safety Engineer to determine pavement marking materials and coordinate quantities to ensure there are no gaps or overlapping in annual restriping. Projects that are not required to include pavement markings per [Section 7.04.01](#), are not required to include pavement markings for work outside of the project limits for annual restriping purposes.

Also see [Section 1.02.18](#) Pavement Marking Plans.

ROAD DESIGN MANUAL

ROAD DESIGN

7.05

TRAFFIC SIGNS AND ROADWAY DELINEATORS

7.05.01 (revised 12-22-2011)

Traffic Signs

The Department has jurisdiction over traffic operational signs (As opposed to local street name signs which are the property and responsibility of the local jurisdiction, and occupy the R.O.W. by permission). The responsibility for preparing any required freeway signing plans will be that of the Design Division – Traffic Sign Unit and/or its traffic signing consultant. The preparation of signing plans for non-freeway is the responsibility of the Region/TSC or a per-qualified signing consult. Design's responsibility will usually be limited to coordinating the signing plans with the project plans.

When a project involves completely new construction or reconstruction, the signing plans should be included as part of the project plans. If the project will be built under one contract, e.g., a two-lane, free access roadway, then the signing will be included with the road plans either as plan sheets or computerized log sheets. If a contiguous section of freeway is being built under several contracts, it is possible that the signing work will be done with a separate contract. Even if this happens, some foundation and sign base work may be included in the road and bridge contracts. The Design Unit should contact the Region/TSC Operations Engineer early in the project development stage to determine if signing will be a part of the project. Also a copy of the correspondence should be given to Design Division – Traffic Sign Unit. If the signing contract is being done with a separate contract, the Design Unit should also contact the Traffic Sign Unit to confirm that all items are included in their respective contracts.

7.05.01 (continued)

As mentioned above, signing plans will generally be prepared by the Design Division – Traffic Sign Unit or Region/TSC Traffic & Safety. There may be occasions, however, where time constraints will necessitate Design completing the final drafting of signing plans from preliminary layouts furnished by the Region/TSC. Design should contact the Reflective Systems Unit, if the Region/TSC has not submitted special provisions and support standards with plans. The role that the Traffic Sign Unit, plays is one of review and coordination between the Region/TSC and Design.

Salvaged signs remain the property of the Department and components will be re-used, whenever possible, by Maintenance and the sign shops.

For signing on detours see [Section 12.05](#).

7.05.02 (revised 9-25-2017)

Delineators

See Standard Plan R-127-Series, "Delineator Installations" for information on both rigid-post and flexible-post delineators.

The contract items of "Delineator Reflector", "Post, Rigid, Delineator", and/or "Delineator, Reflective Sheeting", and "Post, Flexible Delineator" shall be used on all 3R/4R road construction projects for divided highways, freeways, and undivided high-speed roadways having curves with radii $\leq 1910'$. Inclusion of these items should also be considered on divided highway and freeway CPM projects depending on the condition of existing devices and the pavement remaining service life.

The rigid delineator measurements and payments are for Delineator Reflector, of the color specified, measured as "each" (back-to-back reflectors on a single post are counted as two) and Post, Rigid, Delineator, also measured as "each".

ROAD DESIGN MANUAL ROAD DESIGN

7.05.02 (continued)

Delineators

The flexible delineator measurements and payments are for Delineator, Reflective Sheeting of the color specified, measured as "each", and for Post, Flexible, Delineator, also measured as "each".

Delineators with Red are to be used where red delineators are attached to the back of delineators on ramps to face possible wrong-way traffic movements.

ROAD DESIGN MANUAL

ROAD DESIGN

7.06

FENCING

7.06.01

References

- A. Standard Plan R-97-Series, High Tensile Eight Wire Fence
- B. Standard Plan R-98-Series, Chain Link Fence (Using Tension Wire)
- C. Standard Plan R-101-Series, Woven Wire Fence
- D. Standard Plan R-102-Series, Installation of Woven Wire Fence (At Structures)
- E. *An Informational Guide on Fencing Controlled Access Highways*, AASHTO, October 1967. (This is the latest edition published.)
- F. Construction Manual, MDOT, Section 6.21

7.06.02

Purpose of Fence

Reference "E", above, states, "Fencing along a highway is a means of preventing unwanted and likely hazardous intrusion of animals, people, vehicles, machines, etc., from outside the right-of-way line into the vicinity of moving traffic." In the early days of the development of our highway system it was considered the responsibility of the abutting property owner to keep livestock within bounds. If someone's horse got out on the road and was hit, it was the owner's fault and owner's loss. Today, with higher vehicle speeds and controlled access operation, the driver has the expectation that the road will be clear of roadside interference. It therefore has become increasingly the highway agency's responsibility to safeguard against unwarranted intrusion on the highway.

7.06.02 (continued)

Only controlled access highways are routinely and continuously fenced. Exceptions, on such highways, are where it can be definitely established that a fence is not necessary, such as in areas of precipitous slopes or natural barriers.

7.06.03 (revised 8-18-2014)

Types of Fence

The following types of fence are used for the applications indicated:

A. Woven Wire Fence

Woven wire fence, nominally about 4'-0" high, is the predominant fence used in rural areas. Steel posts are used, unless the fence is in swampy soil, in which case wood posts are used. The type of post, whether wood or steel, must be indicated in the pay item, which means that the designer must estimate where swampy soils will be encountered along the R.O.W. line. Normally, steel posts are less expensive than wood, so a contractor will want to use steel if possible. There have been cases where the contractor has asked to use wood posts throughout a project, and this has been allowed.

B. Chain Link Fence

Chain link fence is predominantly used in urban areas. Sometimes a project will require both woven wire and chain link fence, if the character of the adjacent development is both rural and urban. If this is the case, the change over point should be selected at a convenient location at or near the end of the urbanized section and not necessarily at the city limits.

ROAD DESIGN MANUAL ROAD DESIGN

7.06.03 (continued)

Types of Fence

C. High Tensile Eight Wire Fence

High Tensile Eight Wire Fence, as a right-of-way fence, is a substitute for woven wire fence. It is thought to be more economical to construct because it consists of individual strands of wire and has no vertical tie wires. It is considered to be more economical to maintain because a broken wire can be spliced with a patented device and re-tensioned, an obvious advantage when compared with the rehabilitation of a broken down or cut woven wire fence. Designers should consult with the Region/TSC and determine at the time of the plan review meeting whether high tensile eight wire fence should be used.

7.06.04

Location of Fence

Fence is ordinarily constructed 1'-0" inside the R.O.W. line. This is in accordance with an old common law custom that the owner of the fence should be able to theoretically construct and maintain it without setting foot on the neighbor's property.

On urban freeways, where fence is used between the freeway and the parallel service road, the location of the "R.O.W. line" between the two is often undefined. Usually, the fence will be placed at a determined distance from the inside service road curb, which may be as little as 3' to as much as 20' to 25'. The wider margin allows greater flexibility for landscaping and plantings, but the municipality must be willing to accept the greater maintenance responsibility. The fence should not be set back at a greater distance if the reason for doing so is to justify paving the area. See details of a typical fence installation between a service road and urban freeway in [Section 12.01.05](#).

7.06.04 (continued)

In rural areas, the R.O.W. line will often coincide with a quarter or section line, which also may have formerly been a property boundary when the area was farmed. These old fence lines frequently became a depository for stone piles and/or were allowed to grow into a tree line. The question of whether to remove the trees and stone piles, or to place the fence inside the R.O.W. line to avoid the costly removal, has been faced repeatedly over the years. Department practice is, if at all possible, to remove the debris and vegetation sufficient to place the fence 1'-0" inside the R.O.W. line. However, it must be remembered that a fencing contractor is not equipped, nor does the contractor have the personnel, to do extensive clearing. While clearing of the line is included in the price paid for fencing, it is customary to allow the fence to veer around a large tree to avoid having to remove it.

When chain link fence is used on urban freeways, the gapping out for ramps and the fence overlap should be accomplished as shown on the next page.

ROAD DESIGN MANUAL ROAD DESIGN

7.06.04 (continued)

Location of Fence

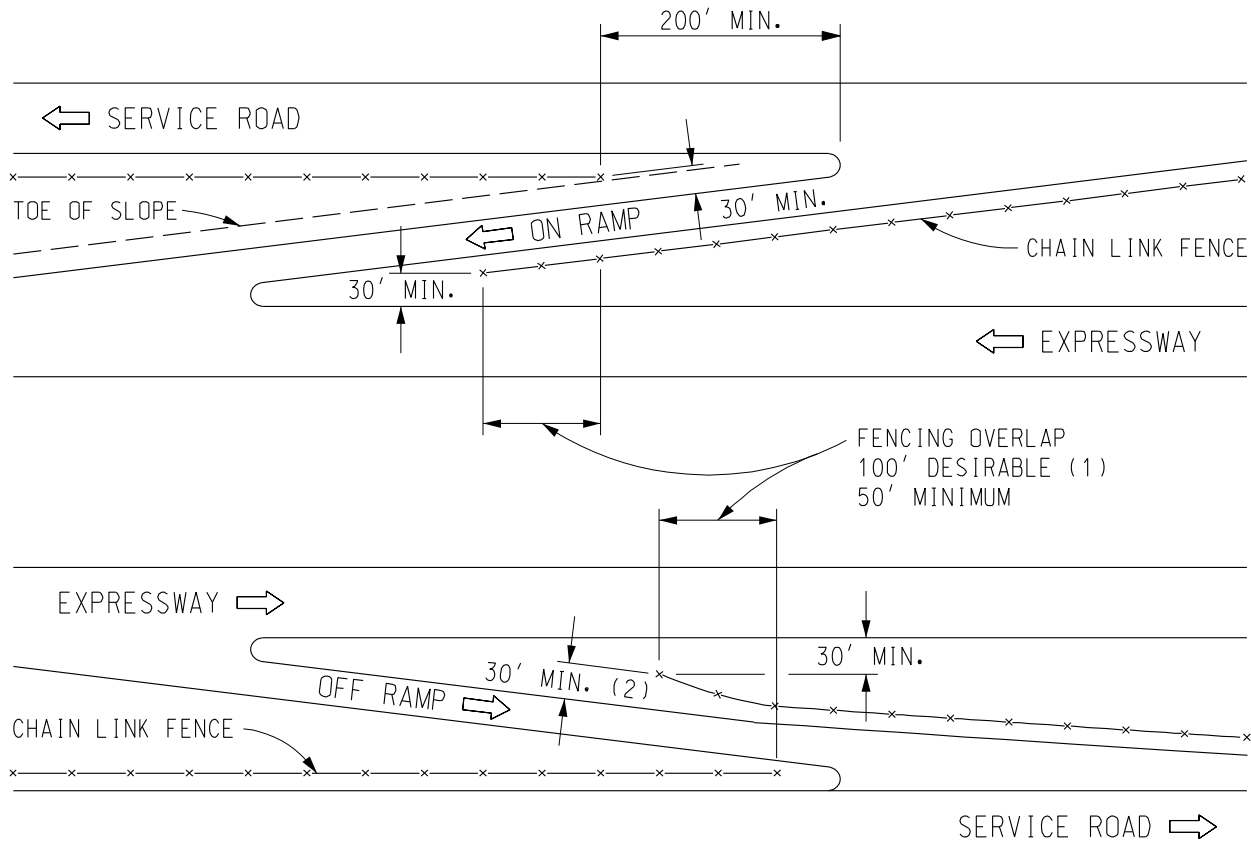

(1) USE LESS THAN 100' ONLY WHEN REQUIRED TO SATISFY MINIMUM OFFSET FROM ADJACENT EXPRESSWAY LANES OR GORE AREAS.

(2) MINIMUM OFFSETS FROM EXPRESSWAY HAVE PRIORITY.

ROAD DESIGN MANUAL

ROAD DESIGN

7.06.05

Use of Barbed Wire

In rural areas subject to stock grazing, woven wire fence has traditionally been topped with a single strand of barbed wire. This was done to discourage farm animals from leaning over the fence and breaking it down. However, there are areas where it is obvious that grazing will never occur, e.g., across state and federal forest lands. When this condition occurs, the barbed wire should be omitted, for economy.

Barbed wire is seldom used in conjunction with 4' and 6' chain link fence. (See [Section 7.06.10](#)) It may be used on top of 8' and 10' chain link fence adjacent to areas where special security measures are required, as around an industrial plant. In these cases the number of strands, and the direction they will be angled, will be as requested by the adjacent property owner, and may be part of the R.O.W. agreement.

7.06.06

Chain Link Fence

Both 4' and 6' chain link fence are used, with the higher fence favored adjacent to platted subdivisions. To avoid intermittent stretches of varying heights of fence, the designer should attempt to limit any one run of either 4' or 6' height to a minimum of 660' or 40 rods.

Initially, chain link fence was constructed on our projects using a pipe top rail. In 1973 the standard plan was changed to provide a tension wire that would replace the top rail on new construction. If the scope of a project includes alteration or updating of chain link fence that has a top rail, the fence should be modified to provide the tension wire, and the top rail should be removed.

7.06.06 (continued)

Chain link fence may cause a special problem at airports that are large enough to use radar, as the fence fabric has been known to cause ghost images on radar screens. Whenever new fence is contemplated adjacent to a major airport, the designer should coordinate the proposed project with the Federal Aviation Administration. It may be necessary to use a non-metallic fence through the area off the end of the runways.

There are also occasions when a woven fence is warranted because of the surrounding rural topography but the adjacent property owner may specifically request chain link fence. On one project where this occurred, in the Metro area, an agreement was worked out whereby the Department furnished the fencing materials and the property owner erected it at their own cost.

When the R.O.W. corridor has been purchased well in advance of construction, and subsequent residential areas have developed adjacent to the R.O.W., it is not unusual for the property owners to place their own chain link fence on the R.O.W. line, in their backyard. When the time comes to fence the freeway R.O.W., the question arises, "should a second chain link fence be erected 1'-0" from the existing fence so that the Department has complete ownership of the R.O.W. fence?" While this has been done, it creates an unsightly trash collector, it makes both fences difficult to maintain, and it is unnecessarily costly. The new fence should simply tie into the existing fence at its ends, assuming that the existing fence is in good condition. If it is not in good condition, then an agreement should be sought with the property owner to remove the existing fence and allow it to be replaced by the freeway R.O.W. fence.

ROAD DESIGN MANUAL ROAD DESIGN

7.06.07 (revised 10-22-99)

Gates in Chain Link Fence

Gates should be provided in chain link fence to provide access for maintenance equipment, e.g., mowers, cranes for servicing pumphouses, etc. Width of gates should be a minimum of 8'. The exact location and width of gates will be determined by Region/TSC personnel at the time of the plan review meeting.

Gates should preferably swing in toward the freeway, and not out onto the service road where an open gate could be struck by service road traffic. If the service road shoulder slope is continued upward past the fence it could cause problems opening the gate unless the earth is graded out somewhat to accommodate the arc of the gate swing.

7.06.08 (revised 2-27-2012)

Fencing Clear Vision Areas

Clear vision areas are usually fenced, but it is not a rule that they must be. There are situations where the property owner may wish to maintain the clear vision triangle as mowed lawn, in which case a fence across the corner would detract from the overall appearance and inhibit trimming and mowing. In these cases, the omission of the fence will be a consideration in the negotiation with the property owner, and safeguards to protect the integrity of the clear vision area will be included in the legal documents. These safeguards will include prohibition against parking equipment and vehicles in the area, and keeping trees trimmed high so that there is a clear line of sight. The designer should set up fencing of clear vision areas on the plans unless informed by the Development Services Division to omit it at specific locations.

7.06.09

Fencing Scenic Strips

Scenic strips located adjacent to limited access R.O.W. are usually fenced along the back and sides, but not along the regular R.O.W. line in front of the strip. Occasionally a scenic strip was acquired after the R.O.W. was fenced, in which case the area may be completely enclosed by fence. If for some reason this happens, a gate should be provided in the regular R.O.W. fence to provide vehicular access to the scenic strip. No driveway should be provided, however.

7.06.10 (revised 4-22-2019)

Fencing Borrow Area Lakes and Retention Basins

Borrow areas that have been excavated deep enough to form lakes should be fenced with 6' chain link fence, unless ownership is to be transferred to private interests who do not want the fence. Use 6' chain link fence with three strands of barbed wire on top. Show the fence located at least 10' to 15' from the water's edge to enable a vehicle to drive between the lake or pond and the fence. A vehicular gate should be provided. Lakes transferred to the jurisdiction of the Michigan Department of Environment, Great Lakes and Energy (MDEGLE) should be fenced.

Retention basins that can be expected to have 2'-0" or more of standing water for more than a day or two should likewise be fenced.

ROAD DESIGN MANUAL ROAD DESIGN

7.06.11

Fence Between Twin Overpassing Structures

When twin independent structures (without a common backwall) carry a freeway over a crossroad, and there is no interchange, the median should be fenced on each side of the crossroad to prevent or inhibit vehicle or animal entry. The fence should preferably line up with the abutment walls.

7.06.12

Guardrail in Conjunction With Fence

There have been occasions in the past where there has been a reluctance to place guardrail in front of a fence. It should be remembered that guardrail does not serve the function of fence, nor does fence serve the function of guardrail, so if both are needed, both should be constructed. As a matter of practicality, however, the fence should be placed sufficiently behind the guardrail, if possible, to allow room for the expected guardrail deflection. See [Section 7.01.20](#).

7.06.13 (revised 2-27-2012)

Temporary Fence

The Development Services Division does not pay for fencing as part of the **limited access** R.O.W. agreement with property owners. (On free access R.O.W., fencing is paid for as part of the property settlement by the Development Services Division.) This means that a problem could be created through areas of stock grazing in that it could leave pasture land unfenced for months during the construction of the project. A General Plan Note is placed on the Note Sheet that says, "Permanent right-of-way fence shall be constructed as the first operation in cases where the right-of-way cuts across stock grazing areas. Temporary fencing, when ordered by the Engineer, will be paid for at the contract unit price for "Fence, Temp".

7.06.13 (continued)

Temporary fencing is used when it is not possible to construct the permanent fence until necessary grading is completed. This may be in muck storage areas, areas of grading permits, etc. Quantities of Temporary Fence are estimated on the basis of 3% of the total fencing for the project, with a minimum of 1320' or 80 rods. This quantity is shown in the Miscellaneous Estimate, on the Note Sheet. Removal of temporary fence is not paid for separately.

In the event that grading and surfacing are let as separate projects, the R.O.W. fence will, of course, be included in the grading contract, with the above provisions included.

7.06.14 (revised 12-22-2011)

Protective Fence

Protective Fence is woven wire or plastic fence that is placed around deep excavations such as those required for bridges, pumphouses, and other structures. It is used primarily to protect pedestrians and animals, as directed by the Engineer, but may even be used to protect trees. The road plans should, on urban freeway projects, set up an amount of Protective Fence equal to the length of the project in feet, labeling it as "estimated". On other urban projects and on rural projects, call for the item if requested at the plan review meeting.

If the pumphouse or structure is to be let separately, Protective Fence should be included in the plans for that structure. On package projects, coordination will be required between Road and Bridge Design to determine which plans will show the fence required to enclose "bathtub" construction.

ROAD DESIGN MANUAL ROAD DESIGN

7.06.15 (revised 12-27-2022)

Removing Fence

Payment for fencing includes the cost of clearing and cleaning the fence line, which includes any old fencing that may be there, except in areas where "Clearing, Fence" is a pay item. Removal of old fencing that is not coincidental with the construction of new fence should be paid for under the item "Fence, Rem".

When tying highway fencing to an existing intersecting private fence that has had to be interrupted by the construction, necessary corner bracing should be added to the private fence, as required. The plans should call attention to this requirement, which should not be paid for separately.

If fence removal is required, but the quantity is unknown, it is permissible to include the removal in compensation for another pay item.

7.06.16

Screening Fence

Construction of a screening or privacy fence is not a common undertaking of the Department, but it has been done. One that was constructed in East Lansing was wood, having 8' high panels, manufactured commercially. An existing chain link fence was removed and the screening fence placed generally along the former fence line. The screening fence overlapped the chain link fence at the ends by about 3', and the details called for a maximum allowable space underneath of 6", with a 2" space as average. Post were set in concrete 3'-6" deep. The pay item was "8' Screening Fence", measured in linear feet.

ROAD DESIGN MANUAL

ROAD DESIGN

7.07

NOISE BARRIERS

7.07.01 (revised 8-26-2024)

References

- A. 23 CFR 772, ***Procedures for Abatement of Highway Traffic Noise and Construction Noise***, FHWA, October 1997
- B. ***An Inventory of Traffic Noise Levels Along Limited Access Freeways in Michigan***, Revision of Research Report R-1013A, (formerly) Materials and Technology Division, July 1981.
- C. ***A Policy on Geometric Design of Highways and Streets***, AASHTO, 2018 7th Edition
- D. ***MDOT Highway Noise Analysis and Abatement Handbook***, July 2011
- E. ***Noise Barrier Wall Design Guidelines***, MDOT, 2024

7.07.02 (revised 4-24-2023)

General

The concept of traffic noise attenuation became an integral part of highway planning and design in 1976 when FHWA first issued ***Procedures for Abatement of Highway Traffic Noise and Construction Noise*** (currently 23 CFR 772). This regulation established two types of noise mitigation projects, which are continued to the present.

7.07.02 (continued)

Type I projects are for new highway construction, reconstruction of an existing highway, or the addition of one or more lanes to an existing highway. Guidelines for noise levels for residential, commercial, and special sites are listed in 23 CFR 772. If highway noise levels exceed the specified levels, on a regular basis, then noise mitigation must be considered. The warrants for noise barriers or other noise attenuation devices must include an economic cost-benefit analysis.

MDOT indefinitely suspended the Type II Noise Abatement Program in December 2007. Type II guidelines and procedures referenced in this, and subsequent sections are retained for historical purposes.

Type II projects are proposed Federal or Federal-aid projects for noise abatement on an existing highway, with no other concurrent reconstruction or lane addition being considered. This is a voluntary program and states wanting to participate must meet certain requirements. In order to be eligible for federal participation the Department had to establish a "Noise Barrier Policy", prepare an inventory of sites where highway noise levels exceed FHWA noise guidelines, and establish a priority system for treatment of the identified sites.

Noise attenuation is confined almost entirely to freeways, although there are one or two locations in the state where an earth mound sound barrier has been constructed along a free access route. Generally, the distance between access points, i.e., necessitating an opening in a barrier, are so close on a free access road that a barrier would not be practical.

ROAD DESIGN MANUAL ROAD DESIGN

7.07.02 (continued)

Responsibilities for noise barrier investigation, evaluation, and design are generally divided as shown in the following chart:

Technical investigation and analysis	Instrumentation and Data Systems Unit, Construction Field Services Division
Environmental Impact Statement	Bureau of Planning, Transportation Planning Services Division
Choice of noise barrier type, general details of design	Roadside Development Design Unit, Design Division
Noise barrier structural analysis	Bridge Design Special Assignment Unit, Design Division
Noise barrier design details	Road Design Unit, Region/TSC

ROAD DESIGN MANUAL

ROAD DESIGN

7.07.03

Technical Aspect of Sound Transmission

The sound pressure level (SPL) is equal to 20 times the logarithm of the ratio of the sound pressure measured to the reference sound pressure. The reference sound pressure is 20×10 Pascal. The unit of SPL is the decibel. The sound is also A weighted so that the measurement is similar to the frequency response of the human ear. The unit is abbreviated dbA.

Because decibels are in logarithms, doubling the sound pressure only raises the decibel level 3 dbA. Also, an apparent doubling of the sound level to the human ear occurs when the decibel level is increased by 10 dbA. The human ear can perceive a difference at 1 dbA when sound levels are presented on a comparative basis. However, the human ear cannot detect a change in highway noise level until the change amounts to about 3 dbA.

7.07.04

Current Requirements and Practices

23 CFR 772 (current issue is dated October 1997) requires highway noise to be analyzed in each environmental document. If the predicted design year noise level is greater than the stated FHWA noise level guidelines, then the affected residential properties or special sites must be analyzed for possible noise abatement in conjunction with the highway improvement.

The Department has established noise guidelines for Type II noise barrier projects. These guidelines have received FHWA approval.

The Department was also instrumental in obtaining vehicle noise legislation. In 1978, Section 707 of the Michigan Vehicle Code was changed to limit the level of noise that a car, truck, or motorcycle can produce on a roadway. The Department assists local enforcement agencies in administering that law, and makes periodic noise measurements to insure contractor compliance with construction noise specifications.

ROAD DESIGN MANUAL ROAD DESIGN

7.07.05 (revised 12-22-2011)

Process for Type I Projects

Type I projects are initiated by the environmental document prepared for each highway improvement project, whether it be an EIS or FONSI, with the Construction Field Services Division preparing the entire noise portion of the document. All homes are analyzed, even those that are widely scattered, though it is recognized that there is not enough money available to treat individual homes with a noise barrier. (Individual homes may be granted an exception to allow them to be treated, however, by adding insulation, solid core doors, storm windows, or air conditioning that would allow the residence to remain closed during hotter weather, thereby reducing interior noise levels.)

Existing subdivisions are examined, the number of homes counted in the first, second, third, etc. rows back from the highway, and the cost of shielding these homes is estimated. The Department's noise policy requires that at least a 6 dBA reduction be achieved in the noise level for attenuation measures to be considered worthwhile. They also set $Leq = 67$ dBA as the guideline for maximum sound level in a residential area. (Leq is the average intensity of sound in the 30th high hour, or at level of service "C", whichever is worse. Level of service "C" is considered the theoretical worst traffic condition for noise; beyond it the movement of traffic starts to break down, with a corresponding reduction in noise levels generated.)

A public meeting or hearing is then held. The Department, however, relies upon input from the local unit of government, rather than the public at large, in making the final determination relative to constructing a noise barrier. Even though all the data may point to the need for a noise barrier, if the public hearing reveals that the people as a whole do not want it, the Department will not build it.

7.07.06

Process for Type II Projects

The construction of Type II noise barrier projects is entirely dependent upon the funding annually set aside for this purpose. The same federal funds that are used for Interstate preservation and capacity improvements also provide funding for noise abatement. Obviously, there is much more potential barrier construction classified as Type II than Type I, as Type II encompasses the entire trunkline system, not just new projects. It is significant when considering Type II projects to know whether or not the highway preceded the construction of a subdivision, or vice versa, as it then becomes a question of whether or not the builders and buyers of homes did so with full knowledge of the highway-related environment. The Department uses the date on which a subdivision was platted, or the date the area was zoned residential, as this date is easily determined and undisputed.

An inventory has been made of the noise levels at all the residential sites along Michigan freeways. There are 1,135 such sites. These are ranked by predicted (as of 1981) noise levels, length of area and "who was there first", and a priority factor is computed. Priority #1 covers those situations where the highway came after the homes, Priority #2 covers those situations where the homes came after the highway.

Mitigation measures are then proposed, an informal public meeting is held, and, as in the Type I process, the Department takes its cue from the local governmental agency whether or not to proceed with the noise barrier. It can be seen that, with 1,135 sites, and treating two or three each year, most will never be treated.

ROAD DESIGN MANUAL ROAD DESIGN

7.07.07 (revised 8-26-2024)

Design Considerations for Noise Barriers

For information regarding noise barrier wall type selection, placement, plan preparation and other design considerations see the [Noise Barrier Wall Design Guidelines](#). The Roadside Development unit will work closely with the Road design unit in choosing details of the noise barrier.

7.07.08

Section deleted.

7.07.09

Section deleted.

ROAD DESIGN MANUAL

ROAD DESIGN

7.08

MAILBOX POSTS

7.08.01 (revised 10-21-2013)

References

- A. Standard Plan R-74-Series, Bumper & Parking Rails, and Misc. Wood Posts
- B. *Roadside Design Guide*, AASHTO, 2011, Chapter 11

7.08.02 (revised 10-21-2013)

General

Typically, the post supported rural mailbox is private property that occupies the R.O.W. by permission. During construction activities, the Department assumes the responsibility for maintaining serviceability of existing mailboxes. After construction activities are completed, the Department or its contractor will place a department approved support at the permanent location, remove the mailbox from the old support and attach it firmly to the new post, and dispose of the old support. The property owner shall be given the option of disposing of the old support. Existing newspaper boxes are removed and stored for the property owner's future installation and are not paid for separately.

Even though the authority to regulate mailbox installations is not well defined, the property owner should be discouraged from reconstructing unusual mailbox installations. Crash tests seem to show that the mailboxes that remain attached to the post go down under impact and away from the vehicle. Attaching several boxes to one large horizontal support is discouraged by Chapter 11 of the *Roadside Design Guide*, AASHTO, 2011. Department standard plans now show

7.08.02 (continued)

a mailbox post having a smaller cross-sectional area than previously. Alternate mailbox support designs meeting the performance criteria of NCHRP Report 350 or MASH may be used as approved by the Engineer.

7.08.03 (revised 10-21-2013)

Design Considerations

As a part of the design, the number of existing mailboxes should be determined and used as a basis for estimating the number of mailbox posts to be placed on the project. Sometimes this can be determined from the plans if buildings are included in the topography shown, but this method is usually not as accurate as actually counting those in the field. The photolog is a reliable source of this information. Internet mapping websites can also be used.

Placement of mailboxes in a curb and gutter section may pose questions, particularly if a curb is being constructed where it did not exist before. If it is a vertical curb, the posts must be within arm's reach of the face of curb; the question then is, are existing boxes concentrated on one side only, or on both sides of the road? If the curb is a roll curb, then the boxes can either be directly behind the curb or at the far edge of shoulder. Either location has advantages and disadvantages. If immediately behind the curb, the post may interfere with the movement of vehicles on the shoulder, pedestrians, and bicyclists, as well as snow removal on the shoulder. If placed at the far edge of the shoulder, the shoulder should be strong enough and wide enough for the delivery vehicle to get completely off the road. Snow removal may not always be complete to the point that the shoulder area is clear, back to the boxes. Generally, however, it has been our practice to place the boxes, in a roll curbed section, at the back of the shoulder, particularly if the purpose of the roll curb and paved shoulder is to provide a bicycle path. Traffic volume and speed are considerations that will influence the location of mailboxes in a roll curb and gutter section.

ROAD DESIGN MANUAL

ROAD DESIGN

7.09

CONCRETE STEPS

7.09.01

General

Concrete steps, with a pipe handrail, are not built as part of a highway project as frequently as they once were. Before designers were as conscious of safety and clear zones as they are now, it was not uncommon to construct concrete steps on a cut backslope to facilitate a property owner's access to a mailbox. This would not normally be done anymore, because the concrete structure would probably be located within the clear zone. Steps are, of course, constructed to facilitate frequent access up or down steep slopes. Before a decision is made to provide steps for this purpose, the designer should be satisfied that the structure is indeed outside the clear zone. In the rare case that concrete steps are included in a project, consult the Roadside Development Unit for step details and requirements.

7.10 (added 10-28-2024)

LANDSCAPING GUIDELINES IN MDOT RIGHT-OF-WAY

All **limited access right-of-way** landscaping must adhere to MDOT Road Design Manual [7.01.11C](#) with the additional criteria that no tree planting is allowed on traversable (non-recoverable) fill slopes (between 1:4 and 1:3) and at least 10' past the bottom of such slopes. Mature trees 4" and greater measured at 4'6" above ground, are considered obstacles and the guidelines from subsection [7.01.11](#) should be considered.

The clear zone is defined in the MDOT Road Design Manual [7.01.11.A.1](#). Furthermore, as indicated in [7.01.11](#), trees should be placed at least 50 feet off the edge of traffic lane on freeways. However, multiple stem shrubs or ornamental trees that are 4" or less in diameter, measured at 4'-6" above ground when mature, may be used since they are considered breakaway if they don't interfere with sight distance. This includes most multi-stem, small ornamental trees.

Clear sight distance areas must be maintained in interchange merge areas, throughout horizontal curved alignment and at ramp terminals. Sheets 3 and 4 of [GEO-300-Series](#) shows all areas where plantings are restricted. All proposed landscaping plans must be reviewed for actual site conditions and clear zones increased for steeper slopes, etc., in accordance with MDOT Road Design Manual [7.01.11](#).

ROAD DESIGN MANUAL ROAD DESIGN

7.10 (continued)

LANDSCAPING GUIDELINES IN MDOT RIGHT-OF-WAY

All **free access right-of-way** landscaping must adhere to clear zone guidelines established in the MDOT Road Design Manual **7.01.11C**. Where design speed is 40 mph or greater, a 10' minimum offset is required. With design speeds greater than 25 mph and less than 40 mph, a 6' minimum offset is allowed behind curb. Where design speeds are 25 mph or less through a central business district with curb and permanent on street parking is provided, landscaping can be installed a minimum of 1.5' behind the back of curb. In no case shall landscaping be allowed to interfere with sight requirements. If the above offsets cannot be provided, shrubs and other plantings are recommended instead of trees.

7.10 (continued)

All perennials and shrubs must be kept low with a 30" maximum height (measured from the road pavement elevation) and all street trees must have a minimum under clearance of 7' to ensure clear vision requirements are met.

Finally, on two-way roads, the area on the inside of horizontal curves should be kept clear to provide adequate passing sight distance.

See attached illustrations as guides for landscaping placement.

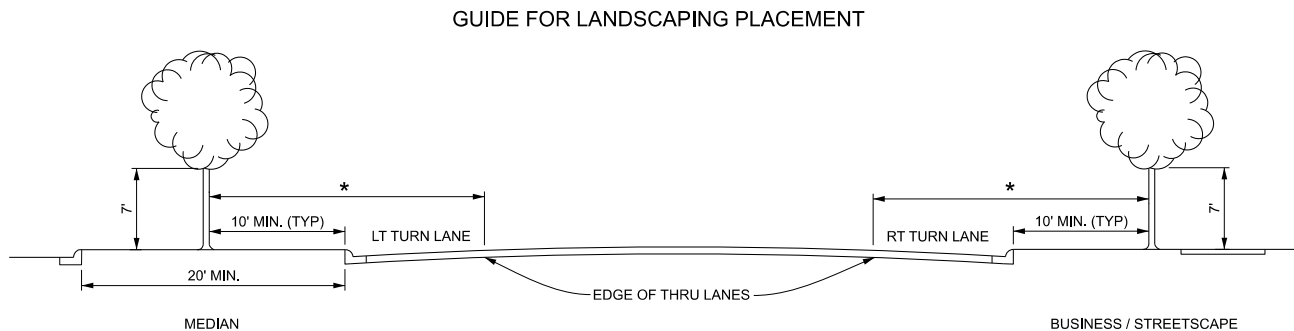

TREE PLANTING GUIDE FOR CURBED AREAS 40 MPH OR GREATER

* CLEAR ZONE DISTANCE MEASURED FROM EDGE OF THRU LANES DESIRABLE

ROAD DESIGN MANUAL ROAD DESIGN

7.10 (continued)

LANDSCAPING GUIDELINES IN MDOT RIGHT-OF-WAY

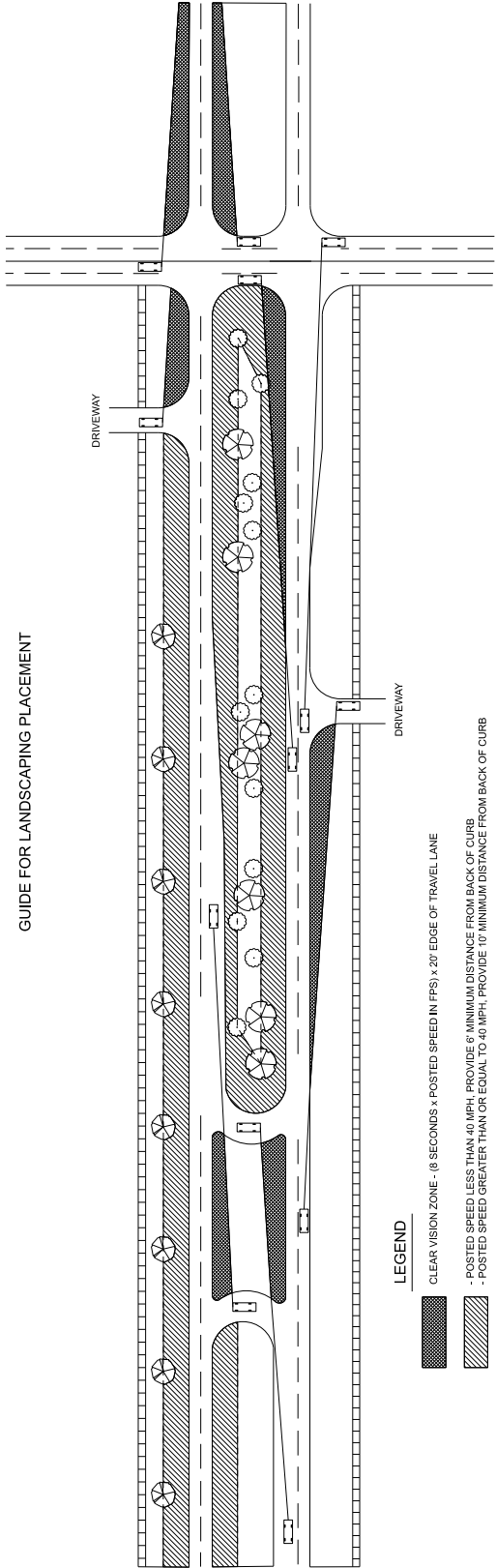

GUIDE FOR LANDSCAPING PLACEMENT

LEGEND

— CLEAR VISION ZONE - (8 SECONDS x POSTED SPEED IN FPS) x 20' EDGE OF TRAVEL LANE

- POSTED SPEED LESS THAN 40 MPH, PROVIDE 6' MINIMUM DISTANCE FROM BACK OF CURB

- POSTED SPEED GREATER THAN OR EQUAL TO 40 MPH, PROVIDE 10' MINIMUM DISTANCE FROM BACK OF CURB

- SEE MDOT SIGHT DISTANCE GUIDELINES FOR INTERSECTION SIGHT DISTANCE REQUIREMENTS