

PLAN VIEW OF FRAME

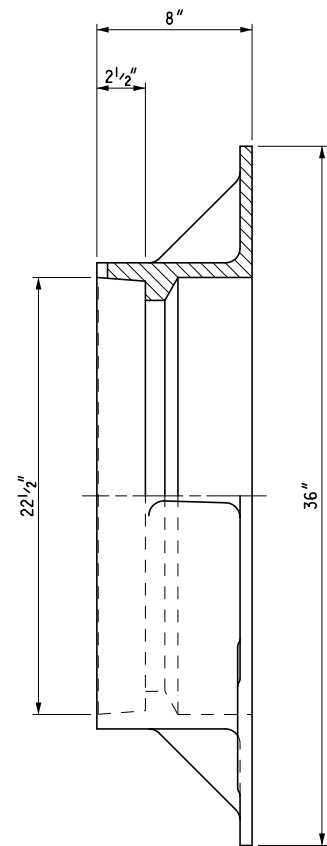

SECTION B - B
HALF FRONT ELEVATION

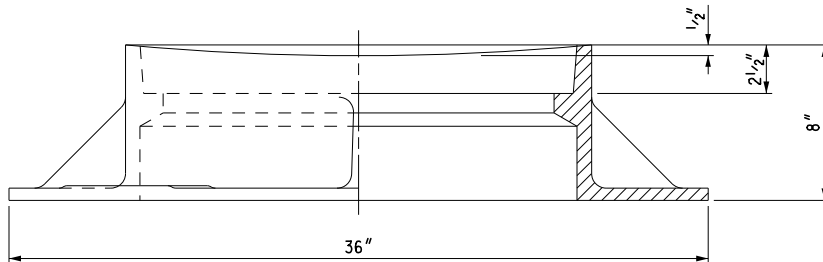

HALF SIDE ELEVATION SECTION A - A



PREPARED BY
DESIGN DIVISION

DRAWN BY: B.L.T.

CHECKED BY: W.K.P.

DEPARTMENT DIRECTOR
Kirk T. Steudle

APPROVED BY: Randy V. Puffel
DIRECTOR, BUREAU OF FIELD SERVICES

APPROVED BY: Mark A. Van Pelt
DIRECTOR, BUREAU OF HIGHWAY DEVELOPMENT

MICHIGAN DEPARTMENT OF TRANSPORTATION
BUREAU OF HIGHWAY DEVELOPMENT STANDARD PLAN FOR

COVER D
FOR USE WITH
STRAIGHT CURB AND CURB & GUTTER

9-30-2014
F.H.W.A. APPROVAL

4-29-2014
PLAN DATE

R-9-D

SHEET
1 OF 2

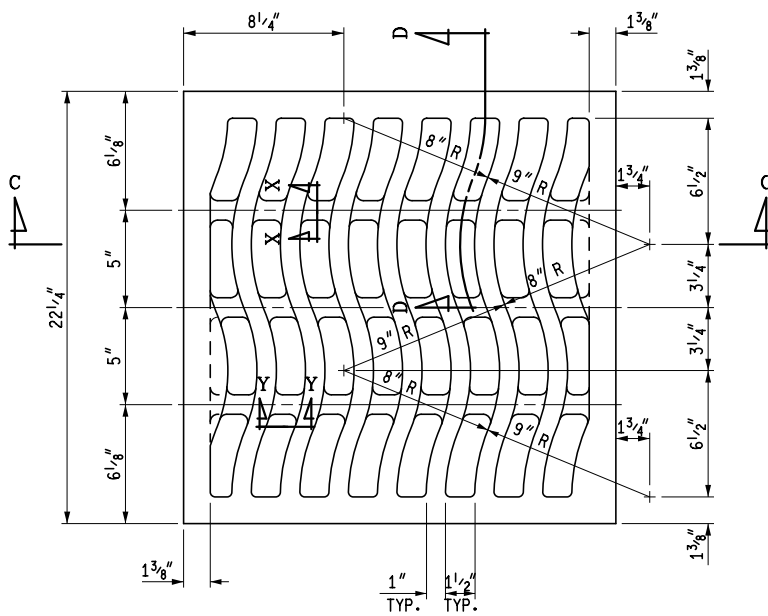

PLAN VIEW OF GRATE

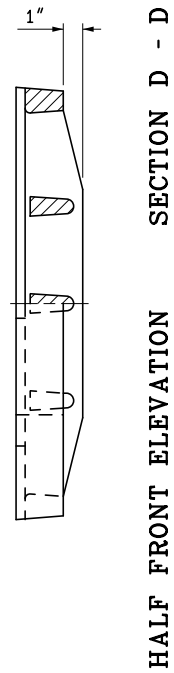

HALF FRONT ELEVATION SECTION D - D

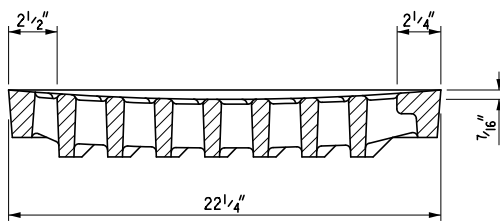

SECTION C - C

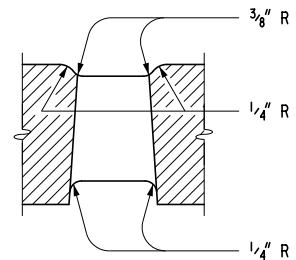
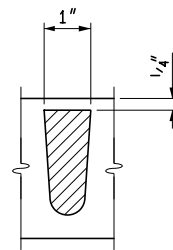

SECTION X - X SECTION Y - Y

NOTES:

THE CASTINGS SHALL MEET THE REQUIREMENTS OF THE CURRENT STANDARD SPECIFICATION FOR GRAY IRON CASTINGS.

ALL CASTINGS SHALL BE CLEANED BY CURRENT APPROVED BLASTING METHODS.

THE SEATING FACE OF THE GRATE AND THE SEAT FOR THE SAME ON THE FRAME AND THE CURB BOX SHALL BE GROUND SO THAT THE GRATE WILL HAVE AN EVEN BEARING ON ITS SEAT TO PREVENT ROCKING OR TILTING.

THE CASTINGS SHALL BE FREE OF POURING FAULTS, BLOW HOLES, CRACKS AND OTHER IMPERFECTIONS. THEY SHALL BE SOUND, TRUE TO FORM AND THICKNESS, CLEAN AND NEATLY FINISHED, AND SHALL BE COATED WITH COAL TAR PITCH VARNISH.

THIS COVER IS DESIGNED TO FIT ON ANY INLET, CATCH BASIN OR ON ANY EXISTING SIMILAR STRUCTURE WHEN SO DESIGNATED ON THE PLANS.

MICHIGAN DEPARTMENT OF TRANSPORTATION
BUREAU OF HIGHWAY DEVELOPMENT STANDARD PLAN FOR

COVER D
FOR USE WITH
STRAIGHT CURB AND CURB & GUTTER

9-30-2014
F.H.W.A. APPROVAL

4-29-2014
PLAN DATE

R-9-D

SHEET
2 OF 2