

HE
336
.T4
R5
1962

3002

JOHN C. LODGE FREEWAY TRAFFIC SURVEILLANCE

— and —

CONTROL RESEARCH PROJECT

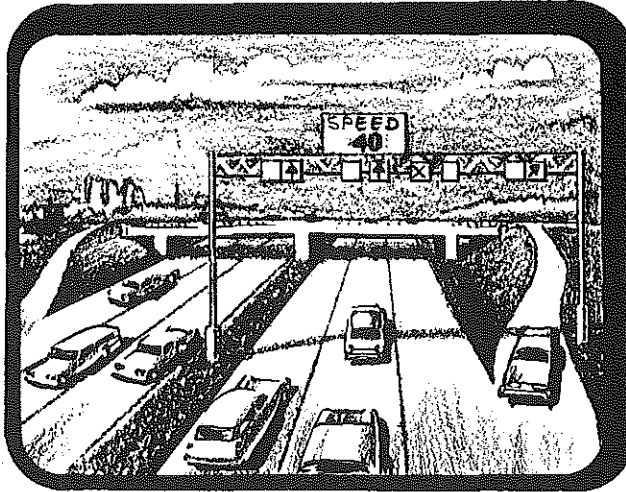

TELEVISION EQUIPMENT
FOR TRAFFIC SURVEILLANCE

LIBRARY
michigan department of
state highways
LANSING

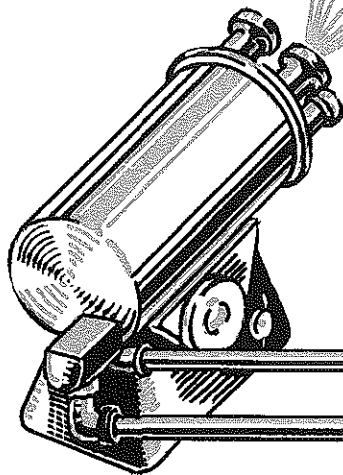

65-3002

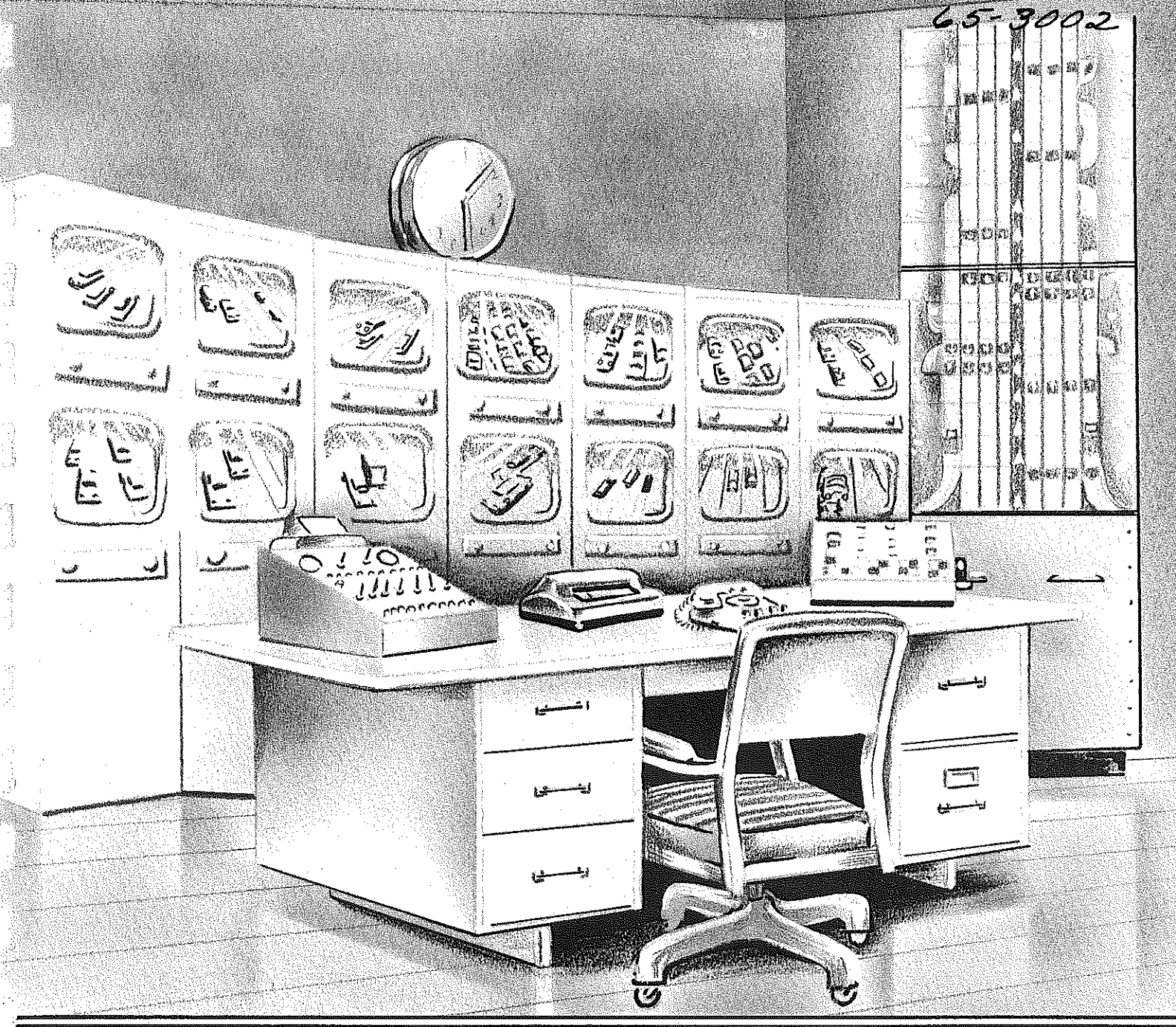

FREEWAY SURVEILLANCE CONTROL CENTER

FREEWAY TRAFFIC SURVEILLANCE AND CONTROL RESEARCH PROJECT

A Project of the
Michigan State Highway Department
Jointly With The
Wayne County Road Commission
City of Detroit, Department of Streets and Traffic
In Cooperation With The
U.S. Bureau of Public Roads

TELEVISION EQUIPMENT FOR TRAFFIC SURVEILLANCE

A Report of the
Project Technical Committee

Charles L. Richard
Electrical Engineer
Michigan State Hwy. Dept.

Keith Bushnell
Systems Engineer
(Former Project Eng.)
Michigan State Hwy. Dept.

November, 1962

FREEWAY TRAFFIC SURVEILLANCE AND CONTROL RESEARCH PROJECT

Policy Committee

Harold H. Cooper, Michigan State Highway Department, Chairman
Oscar M. Gunderson, Wayne County Road Commission
Alger F. Malo, Department of Streets and Traffic, City of Detroit
Harry Krashen, U.S. Bureau of Public Roads

Project Manager

Edward Gervais, Michigan State Highway Department

Project Engineer

Frank DeRose, Jr., Michigan State Highway Department

Technical Committee

Frank DeRose, Jr., Michigan State Highway Department, Chairman
Jean W. Clinton, Wayne County Road Commission
Seymour E. Bergsman, Dept. of Streets and Traffic, City of Detroit
A. Taragin (C.L. Shufflebarger, Alternate) U.S. Bureau of Public Roads

Other Project Personnel

Michigan State Highway Department

Conrad Dudek
Charles Richard
Robert Traill
Walter Roth
Herbert Schoepke

Dept. of Streets and Traffic, City of Detroit

Ross Bremer
Richard Folkers

Technical Assistance Provided By

Keith Bushnell, Michigan State Highway Department
Dr. Theodore W. Forbes, Michigan State University
Robert Larson, Wayne County Road Commission
Holden M. LeRoy, Dept. of Streets and Traffic, City of Detroit
Frank A. Ronan, Dept. of Streets and Traffic, City of Detroit

This project consists of the establishment of a comprehensive system of surveillance and control on an urban freeway. The purposes of the project are to evaluate the use of surveillance, traffic control and sensing equipment; to investigate the characteristics of the freeway traffic flow which may be determined and treated by such equipment; to improve freeway traffic operation and safety by these means, as well as to conduct basic research into freeway operations by making use of this specialized equipment. For the first time, it has become possible to assemble the specialized equipment required to carry on a project of this scope.

The project is sponsored jointly by the Michigan State Highway Department, Wayne County Road Commission, and City of Detroit, Department of Streets and Traffic, in cooperation with the United States Bureau of Public Roads. The following report pertains to one of a number of individual studies to be performed. Each of the studies will be reported separately as it is completed and each will contribute to the overall objective of this study.

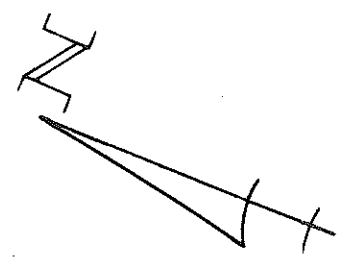

**FREEWAY TRAFFIC
SURVEILLANCE AND
CONTROL RESEARCH PROJECT**
ON
JOHN C. LODGE FREEWAY
DETROIT, MICHIGAN

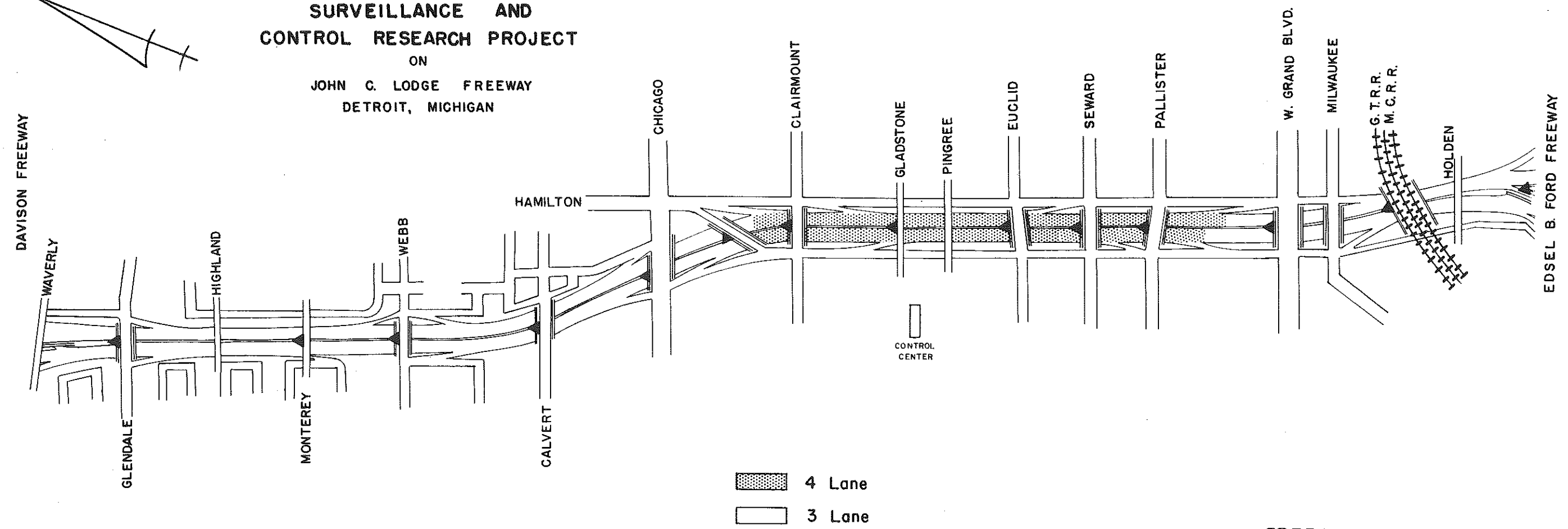

▲ T.V. CAMERA INSTALLATIONS

▨ 4 Lane
□ 3 Lane

**FREEWAY STUDY
AREA PLAN**
SCALE 1" = 700' APPROX.

TABLE OF CONTENTS

	Page
Introduction	1
Camera Characteristics	3
Vidicon Tubes	3
Scanning	4
Scanning Rates	8
Horizontal Resolution	9
Video Band Width	10
Transistorization	11
Ambient Operating Conditions	19
Camera Encasement	20
Sensitivity	20
Automatic Target Control	21
Gamma Correction	22
Aperture Correction	24
Camera Accessories	26
Automatic Light Control	26
Lens	28
Remote Focus	30
Remote Turret	30
Pan and Tilt Assembly	31
Camera Enclosure	34
Housing	34
Windshield Wipers	41

Heating	42
Ventilation	43
Remote Control	44
Field Relay Panel	44
Control Panel	46
Video Switcher	48
Monitors	52
Transmission Systems	56
General	56
Balanced Line Video Cable	56
Coaxial Cable	58
Radio Frequency Modulation	58
Micro-Wave Transmission	60
Cable Location	61
Conclusions	62
Appendix A	

TELEVISION EQUIPMENT FOR TRAFFIC SURVEILLANCE

Introduction

Closed circuit television has become an efficient tool for aiding in control of urban freeway traffic. Television cameras properly located can provide an observer with continuous visual information of a large area of freeway. On the John C. Lodge Freeway, 14 television cameras are spaced approximately one quarter of a mile apart so that a continuous 3.2 mile area of the freeway is under observation. From one control point it is possible to observe traffic movements, study driver behavior, determine the scope of an accident, direct rescue activities, operate traffic control devices, and visually assess the results of vehicle sensing equipment in the area.

Without this television system, it would be difficult to develop, install, and operate a lane and speed control system. Twenty months of operation on this project has proven that closed circuit television has "arrived" as a valuable tool for the traffic engineer.

Freeway surveillance proves to be one of the severest requirements placed upon closed circuit television. Tunnels, bridges, and airports have been using closed circuit television but usable pictures were not being obtained under existing low light levels. Since a major part of urban traffic problems occur at dusk or after dark, especially in the winter time, the less expensive vidicon type television camera did not seem too practical. A recent report written for the City of Chicago

stated that the necessity for a picture after dark would require the use of the more expensive image orthicon (Studio) type camera.

Probably the major breakthrough has been the rapid advance in the development of the vidicon tube pickup tube. Large, extensive projects by the military have caused a boom in the development of small closed circuit television cameras, using small vidicon tubes.

The major problem in the planning of any closed circuit television is the selection of the proper equipment which will meet the requirements of the application. The engineer has available a wide range of equipment which varies in function, performance, quality, size and cost. Existing equipment capabilities must be fitted to meet certain performance criteria which will produce an acceptable video picture in a given situation. The basic closed circuit television system consists of cameras, monitors, and a transmission system.

The application of these system characteristics and accessories including limitations and advantages as experienced on this project will be discussed in detail.

Camera Characteristics

Vidicon Tubes:

One of the first and most important decisions which has to be reached in planning the closed circuit television system on a freeway is the selection of the proper camera pickup tube. In the present state of the art, this resolved itself into a choice between a vidicon or an image orthicon type camera tube. The image orthicon tube is considerably larger than the vidicon tube and costs approximately 25 times as much per hour for replacement. Present vidicon tube replacement costs are about \$.08/hour compared to approximately \$2.00/hour for the image orthicon tube. Image orthicon tubes generally have greater sensitivity and are not subject to lag or smear with moving objects, require less operator attention to adjust camera output under varied light conditions and can accommodate a large contrast range. Although new developments in the image orthicon field have reduced the cost of cameras to approximately \$20,000, the cost is still prohibitively high for use in closed circuit television.

The development of vidicon tubes to a point where night application is now practical has made the use of the vidicon camera a practical tool. The vidicon camera also requires less circuitry, is easier to set up, and has a better signal to noise ratio under good light conditions. The disadvantage of sensitivity has been largely overcome with the newer, better vidicon tubes and the lag or smear of the moving object is noticeable only at night when the headlights have a tendency to provide a smear as the vehicle image moves across the monitor screen.

Experience with the 16 camera chain in operation has shown that the tubes can operate or have operated over twelve months on a 14-hour per day basis and are still providing high resolution pictures. Until the image orthicon type camera becomes considerably more economical, a choice of basic camera type will not be too difficult for normal traffic application. All specifications pertaining to cameras in this report will refer to the vidicon type camera.

Scanning:

A second major selection in basic camera characteristics is the choice of types of scanning. Two major scanning systems are random interlace and positive interlace. Random interlace cameras cost from \$1,000 to \$2,000 while positive interlace cameras cost from \$3,500 to \$5,000. Random interlace cameras have approximately 13 tubes compared to over 30 tubes for the positive interlace. Normally maintenance costs of electronic equipment will be proportional to the number of tubes. In complex systems with many accessories, the difference in total maintenance cost may be nominal. Because of the big difference in cost, the two systems will be discussed in detail.

The picture on a television screen is produced by the rapid movement of a beam of electrons which is viewed as a spot of light moving from the left to the right in horizontal sweeps and successive sweeps are formed from the top to the bottom forming a complete picture. As this small dot of light rapidly sweeps the screen, it varies in intensity to produce the range of color from black to white and a special material on the picture tube retains the image for a fraction of a second so that a complete picture is apparent. The light sweeps horizontally

across the picture tube 15,750 times a second and sweeps from the top to the bottom 60 times a second. This results in the dot producing $262\frac{1}{2}$ sweep lines as it moves from the top to the bottom. As it again sweeps the screen required for a complete picture, it now starts a half a sweep late and the resulting second $262\frac{1}{2}$ sweep lines interlace or go between the first $262\frac{1}{2}$ lines. If the interlace is perfect, a picture consisting of 525 sweep lines is developed. All expensive broadcast equipment and positive interlace closed circuit equipment provides this interlace in its transmitted signal.

Positive interlace requires that the camera have an absolute $262\frac{1}{2}$ relationship between the vertical and horizontal drive circuits. This is usually accomplished by having one base oscillator operating at 31,500 cycles per second and special countdown circuits are used to obtain the horizontal frequency of 16,750 cycles per second and the vertical frequency of 60 cycles per second. Such countdown circuits should count more than seven steps in any one stage if good stability is to be attained. Generally speaking, the positive interlace cameras are also better constructed and usually have horizontal resolutions higher than those produced by the random interlace cameras.

An economical and simple scanning system known as non-interlaced or random interlace sweep involves the use of a separate horizontal and vertical oscillator with no tied relationship between the two frequencies. If both the camera and monitor have completely isolated sweep circuits, successive vertical

sweeps or fields will not be exactly on top of each other or exactly interlaced. Actually, each 260 some odd sweep lines will show that adjacent lines appear to be moving closer and farther apart with respect to each other. In the resultant picture, it will appear to have considerably more than 262 lines but probably something less than 525 and will be varying between these two figures.

The choice between positive interlace and random interlace is usually one of money and maintenance since the complexity of the positive interlace usually doubles or triples the circuitry of the camera and increases the cost of maintenance.

The primary difference from the standpoint of the average observer between random interlace and positive interlace is that the picture appears steadier with positive interlace. The random interlace picture may appear to be somewhat watery. A second difference which is harder to discern in the average traffic picture is the difference in vertical resolution or the ability to discern the difference between horizontal lines as they increase in number. This might be explained if the camera were directed at a series of horizontal lines or say a venetian blind where the slats were increased in number until you could no longer count them. In positive interlace closed circuit television, this number would be approximately 375 horizontal lines in the height of the picture. In random interlace this number will vary from approximately 200 to 300. If the horizontal and vertical oscillator can be kept completely isolated so that they do not synchronize upon each other, a vertical resolution of nearly 300 lines can be obtained.

In the cheaper random interlace cameras, the two frequencies will synchronize on each other and successive fields will trace on top of each other with no interlace. The resultant picture caused by this line pairing will be composed of 262 or 263 sweep lines instead of 525 and the vertical resolution will be approximately 200 lines. Loss of resolution due to line pairing is actually greater than the difference noted between positive interlace and a good random interlace.

The choice of a monitor which has no crosstalk or feedback between the vertical and horizontal oscillators is extremely important to keep pairing from occurring. Even in a home television receiver which receives a near perfect interlace type signal from the broadcast station, pairing is quite common. In various experiments and demonstrations, it was found that the monitor was more often responsible for the pairing than the camera. In fact, several demonstrations with supposedly interlaced cameras being used, produced pairing because of the monitor being used.

Original specifications for the TV project did not necessarily require a positive interlace camera. Successive observations between the two types of cameras did not prove that the difference in vertical resolution between 300 line and 375 lines was significant enough to require positive interlaced cameras. The cameras were set to view the freeway from a bridge which crossed the freeway and traffic was viewed for a distance of 1700 feet. The difference in resolution between the random interlace and the positive interlace camera did not vary the detail noted by more than a few feet on the freeway. In other

words, if a stalled vehicle could be determined at 1600 feet in the positive interlace camera. it could be seen at 1500 feet in the random interlaced camera provided the monitors were of such quality that line pairing did not occur.

Many other requirements in the specifications were generally found or could only be guaranteed in the higher grade cameras. Therefore, the lowest bid as supplied by General Electric Company was based upon their positive interlace, TE-9 transistorized camera. Additional studies will be conducted to determine whether positive interlace is a necessary characteristic.

Scanning Rates:

One decision not too difficult to make at the time of the project, but which might be considered at a later date involved the choice of scanning rates. All United States commercial broadcast television is 525 scanning lines per frame or picture or as mentioned 262½ scanning lines per field. With proper interlace, this gives a positive vertical resolution of about 375 lines. Vertical resolution is directly proportioned to the number of sweep lines forming the picture and is equal to approximately 65% of the number of sweep lines. While it is easier for manufacturers to provide high horizontal resolution, it appears that the greatest limitation to overall readability lies in the lack of vertical resolution. There does not seem to be much justification for horizontal resolutions exceeding 600 lines unless the vertical resolution is increased proportionately. It is possible to obtain closed circuit television

with scanning rates of 619 or 825 lines per frame. This would increase the vertical resolution to approximately 420 lines or 550 lines respectively. This type of equipment was not demonstrated in operation on the freeway since it was not commercially available from United States firms. Such cameras are available from French firms and are presently being built for the military by some U.S. firms. These cameras will be available from American camera manufacturers in the near future but may be more costly. Such equipment, if available, should certainly be studied before final specifications of a large complex system are written.

Horizontal Resolution:

The lower cost random interlace cameras easily produce horizontal resolutions of from 300 to 400 lines. This equipment is primarily used with standard broadcast television receivers to provide an economical closed circuit television system. They are generally used in limited applications under ideal light conditions.

It does not increase costs to provide over 500 lines or horizontal resolution with the camera since it only requires higher quality video amplifiers in the camera and monitor circuits. Horizontal resolution is proportional to the frequency handling capabilities of all amplifiers in the camera chain. The frequency band width necessary for a particular resolution may be roughly calculated by multiplying the number of sweep lines per second by the number of light changes required per sweep. Since standard broadcast television uses 525 sweep lines and produces a complete field 30 times per second, the picture is formed by 15,750 horizontal sweeps

per second. To produce a horizontal resolution of 600 lines, the sweeping dot of light must go through light change cycle 600 times for each sweep or $15.750 \times 600 = 9,450,000$ cycles per second. A megacycle is one million cycles and the above changes would be designated as 9.45 megacycles. In actual practice, 600 lines of horizontal resolution can be obtained from amplifiers rated at over 8 megacycles. Since most monitors available for closed circuit television have video circuits capable of passing 8 megacycles, additional costs are found only in the video circuits for the camera.

If the resolution is to be increased above this amount, additional circuits such as aperture correction will be necessary and are usually found on higher priced cameras.

Tests indicated that the difference in resolution from 300 to 550 lines is worth the additional cost. Therefore, it was specified that the cameras would deliver 550 lines of horizontal resolution. Actually the camera in operation delivers considerably over 600 lines and at the time of installation many of the cameras were delivering pictures exceeding 700 lines of horizontal resolution.

Video-band Width:

Video-band width is the technical name used to designate the ability of an amplifier to handle a range of frequencies necessary to produce a picture. A video amplifier is actually an ultra hi-fi amplifier. The hi-fi fan, who is familiar with figures 0 to 20,000 cycles for his audio amplifier, will appreciate the capabilities of an amplifier that will amplify all frequencies from 0 to 8 megacycles (8,000,000 cycles) $\pm \frac{1}{2}$ db. The need for band width is directly proportional to desired

horizontal resolution, as shown in the discussion on horizontal resolution. Generally a camera's capabilities is shown by lines of horizontal resolution. Line amplifiers and monitor capabilities are shown in band width. Naturally all components must have equal capabilities or the output will be only as good as the information passed by the poorest amplifier.

In the equipment installed on the John C. Lodge Freeway, the amplifiers are operating close to 10 megacycles as was proven by the fact that pictures exceeding 700 lines of horizontal resolution were obtained. With the present state of the art, any specifications written which exceed 8 megacycles will considerably limit the amount of equipment which can be bid for a project.

Transistorization:

A third major selection of basic camera characteristics is the choice between a camera using vacuum tubes and one using transistors. When the original specifications were written, there was not much of a choice. Only three transistor cameras were available and none seemed to meet desired requirements. Since then there has been rapid transitions to transistorized cameras, and one company included their new transistorized camera as an alternate bid. Performance tests proved the superiority of the transistor camera which is now being used on the project.

Transistorization has made it possible to provide a fully interlaced camera in one small unit. Previous tube type cameras were forced to use two units so that one unit containing the pickup tube could be small enough for most applications.

Besides the greater size, the thirty some vacuum tubes created a heat problem and greater failure rate. The transistorized camera has overcome the liabilities of size, heat, and maintenance cost of the interlace cameras.

Our maintenance record has shown transistor failure to be negligible. With 59 transistors in each camera there has been approximately one transistor failure per month in the whole system. Nearly as many vacuum tube failures occurred in the monitors with only 25% as many components. Operational experience with this camera has proven that any future installation should be studied for the possibility of using transistorized cameras.

Figures 1 through 6 show pictures of the camera in present use. The camera is $5\frac{1}{2}$ " in diameter, and $11\frac{3}{4}$ " long. Figure 5 shows the cover removed and the layout of all parts on three plug-in boards. These boards are completely wired and all transistors are plug-in for easy maintenance. Figure 6 shows the camera with plug-in boards removed and access to the vidicon tube and three accessory drive motors. One motor drives the turret, the second drives the iris on the lens in use, and the third drives the vidicon tube back and forward for focus. Each motor is remotely controlled from the Control Center by the operator.

The camera uses one miniature vacuum tube to amplify the extremely weak video information received from the vidicon tube. Vacuum tubes have a lower noise level than transistors and have an advantage for amplifying weak signals. Records show that this one tube, type 6021, lasts less than one year and has a higher failure rate than any other component. Present design has eliminated this vacuum tube.

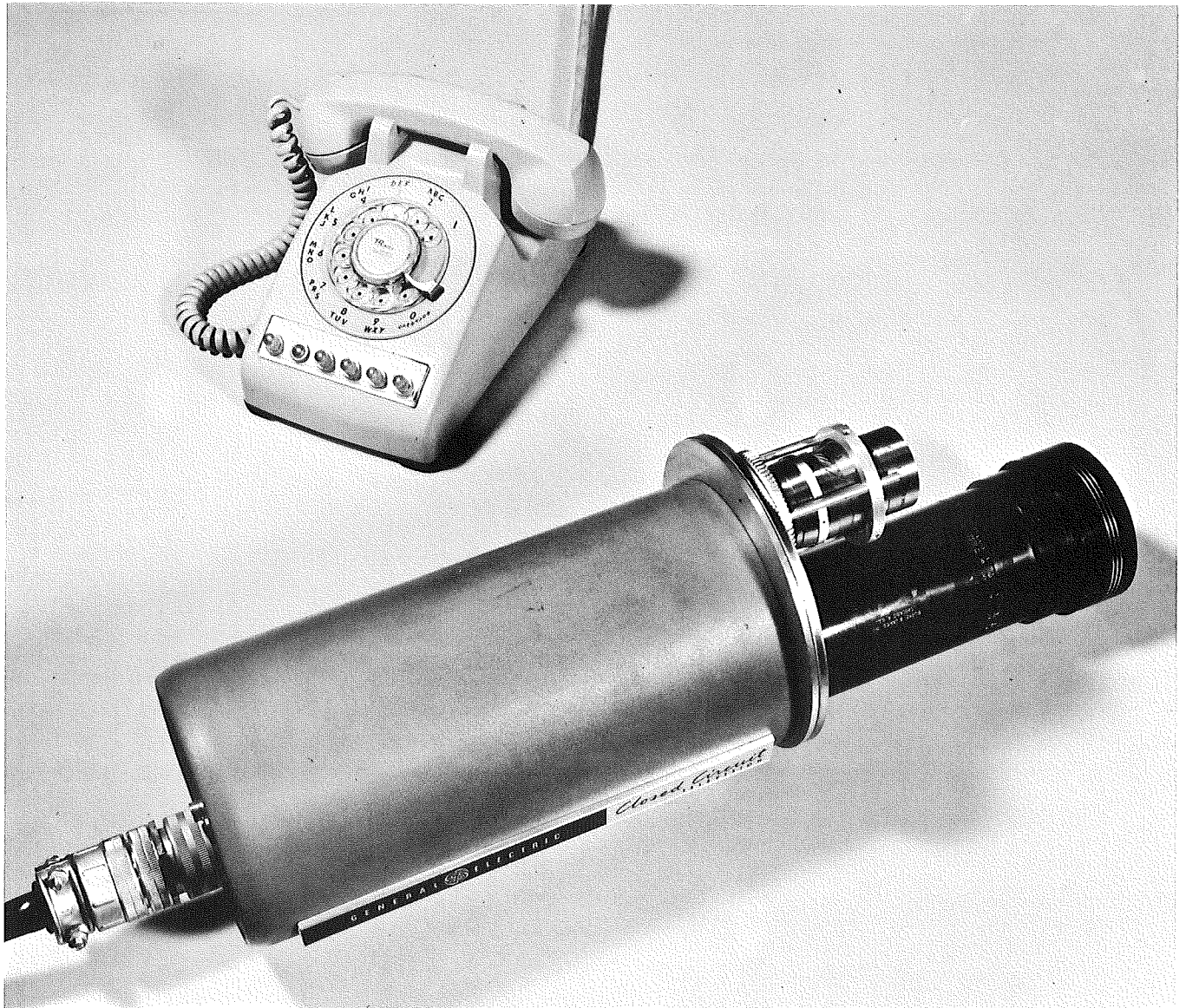

Figure #1

Transistorized camera with 6" telephoto and 1½" wide angle lens mounted on turret. The small size of the camera is readily seen when compared to the standard desk telephone.

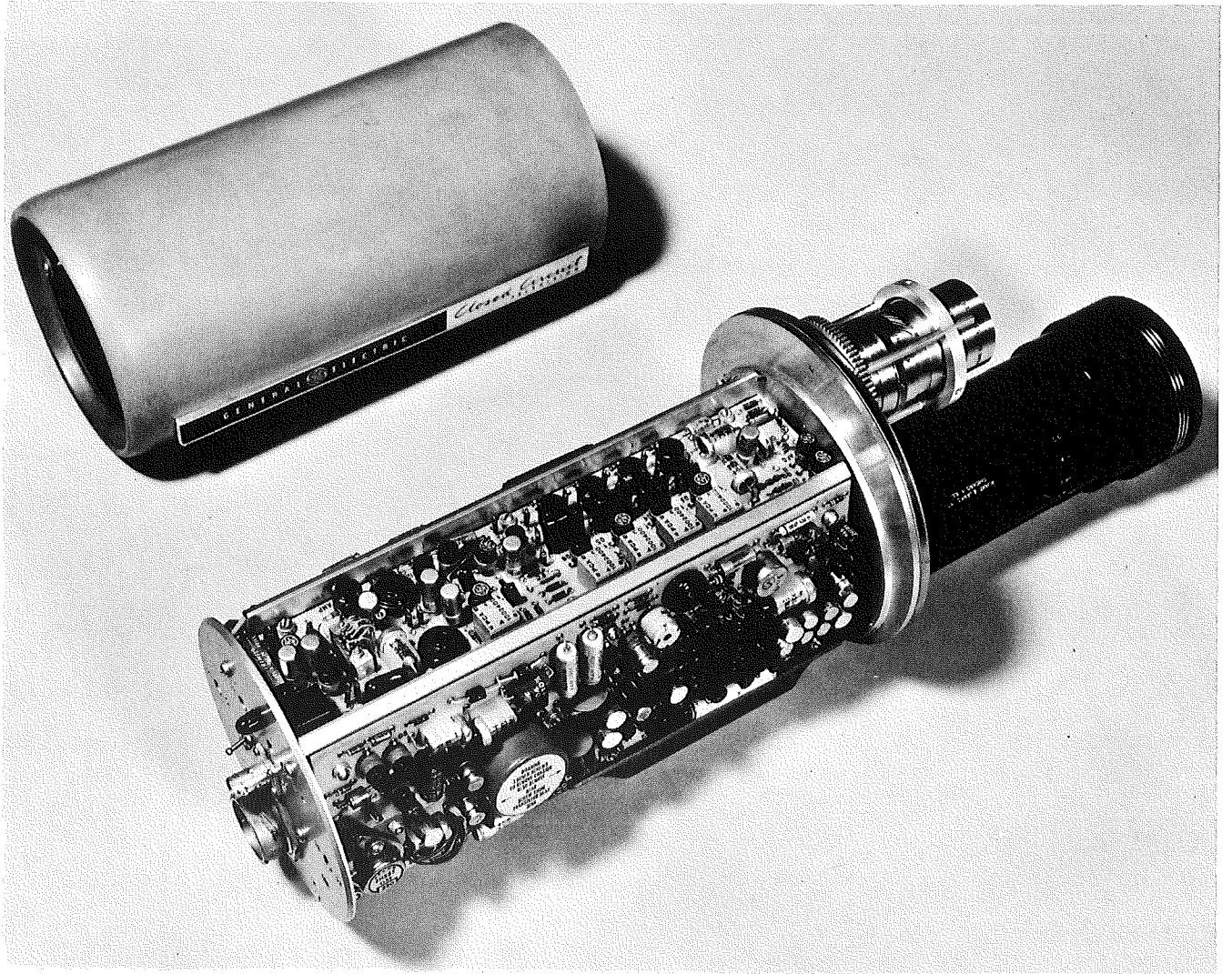

Figure #2

Transistorized camera with cover removed exposing components.

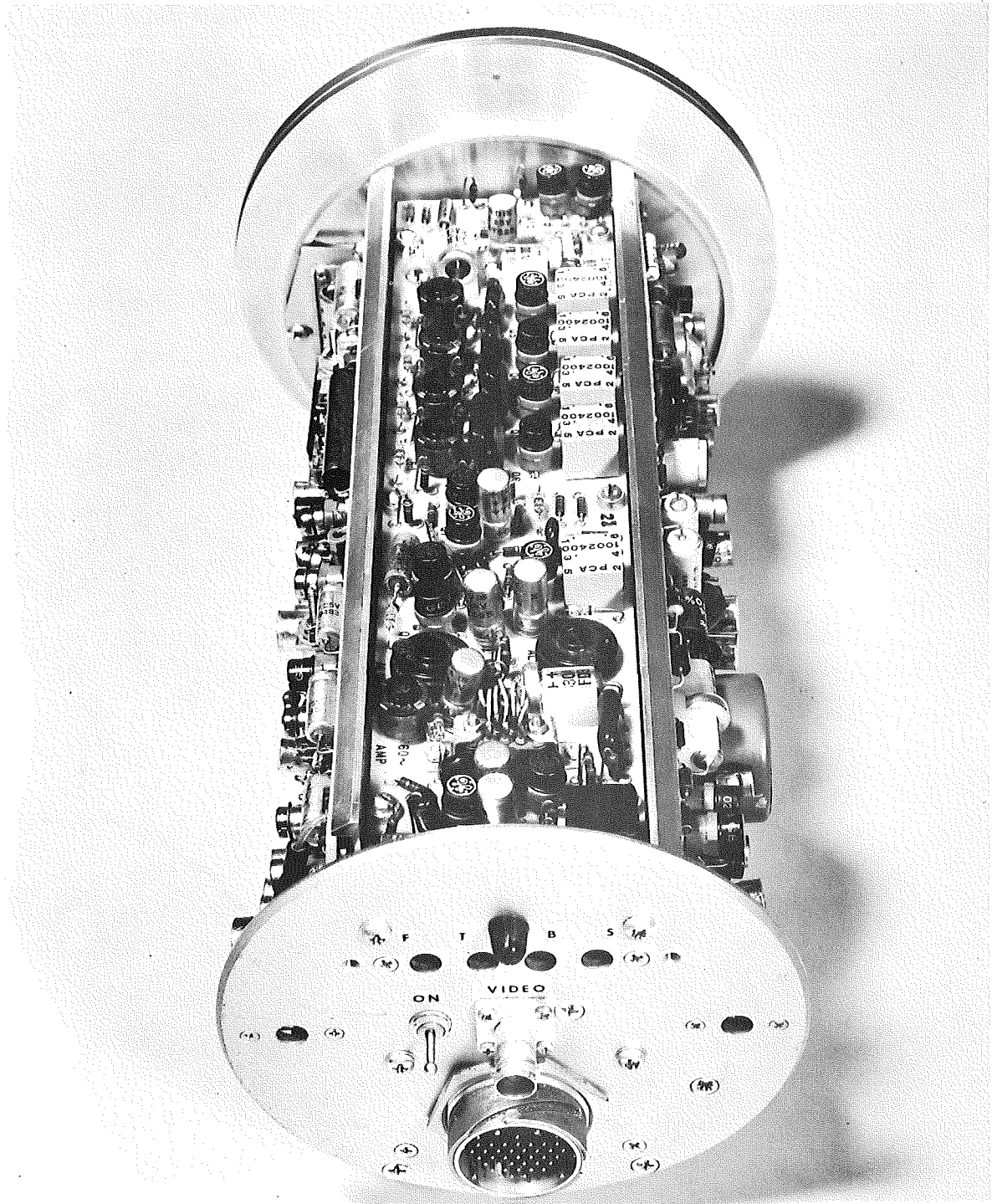

Figure #3

Camera with cover removed showing the three separate component boards. The rear plate has provisions for input-outputs and field adjustments.



Figure #4

Closeup of the only vacuum tube used in the camera.
The tube is used in the first stage of the video output.

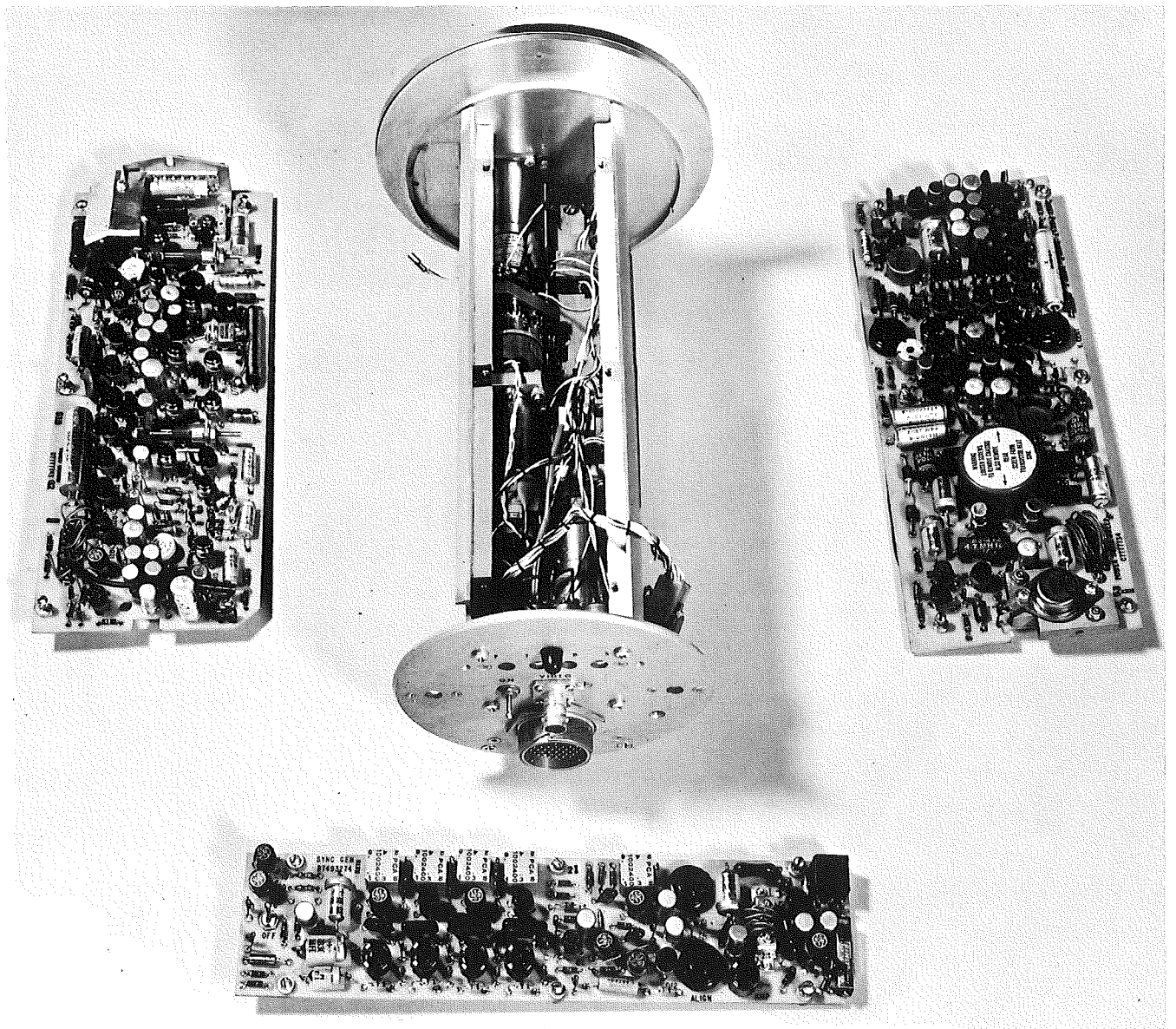

Figure #5

Camera stripped of three boards which contain all circuitry for power video and synchronization. View shows ease of removing parts for maintenance purposes.

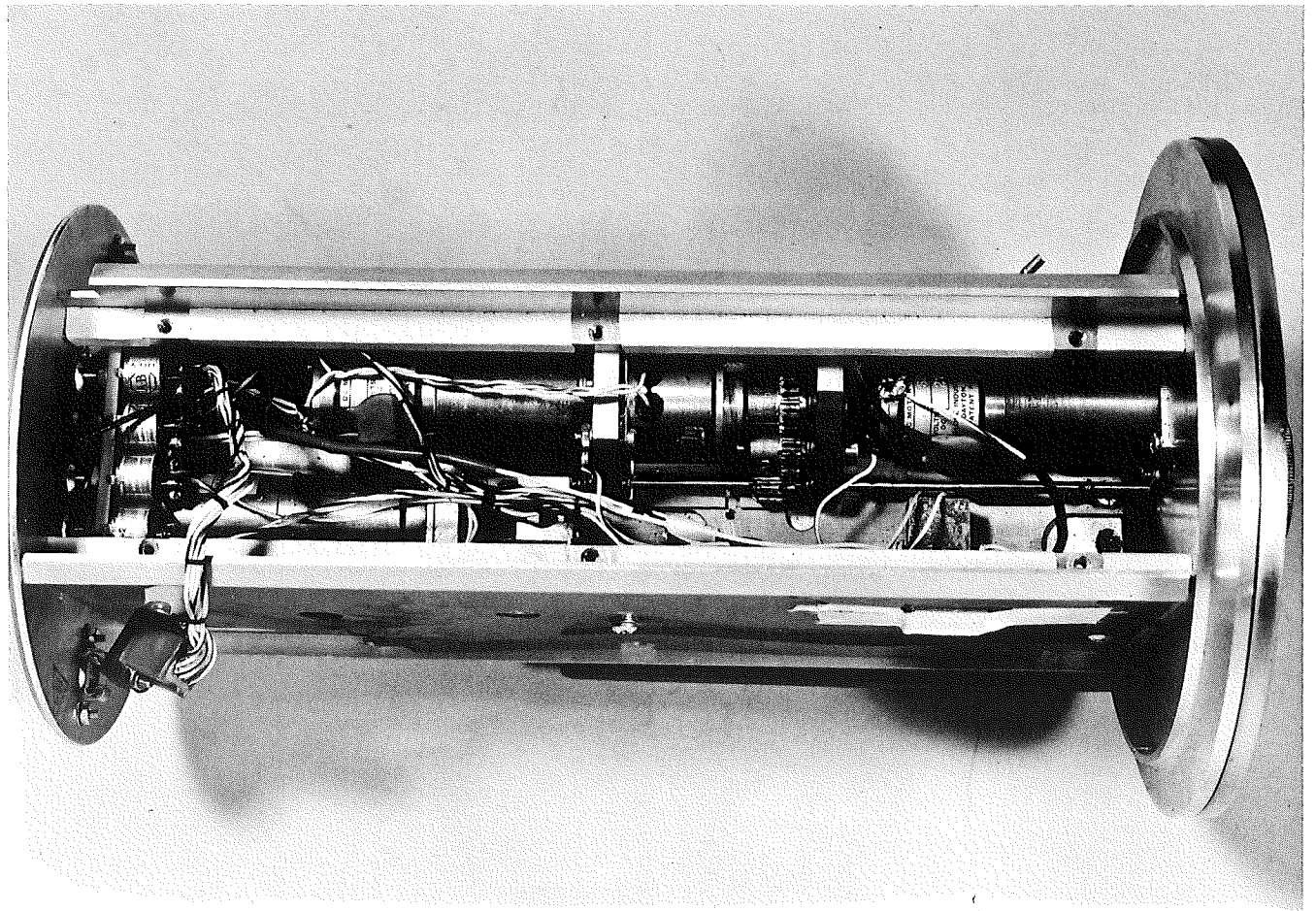

Figure #6

Closeup of camera with all component boards removed, showing focus, turret and iris motors.

Ambient Operating Conditions:

Specifications required that the camera be capable of operating within specifications under the following ambient conditions:

Temperature +10 to 100 degrees F.; humidity, 10% to 100%; altitude, 0 to 10,000 feet. It was also required that no arcing would take place or that the equipment would not be damaged if it was turned on or operated between the temperatures of - 10 degrees F. and 130 degrees F. The cabinets for which the cameras were to be installed were designed to be heated in the winter and ventilated in the summer.

Specifications on vidicon tubes indicated that the tube will not produce a good picture if temperature went below 70 degrees F. The vidicon tube generates some heat and is enclosed in the camera. It was found that the cameras produced a very satisfactory picture with cabinet temperature down to 32 degrees F. by leaving camera power on continually. When the system is not in operation, the vidicon tube is remotely capped while the turret and camera power remains on. This method of operation has required less maintenance as the camera components are always heated. In the large camera enclosures used by the project, it has been very difficult to provide enough heat to maintain a cabinet temperature above 60 degrees F. at all times. If the camera power can be left on at all times, the cabinet surrounding the camera would not have to be heated until the temperature drops below freezing.

Camera Encasement:

The camera itself must be in a practically air tight case. In order to properly ventilate the camera housing in which the camera is installed, a fan has to circulate air past the camera. In spite of the installation of filters, large amounts of salt spray and dust are collected inside the housing. This foreign material can enter the camera through the adjustment openings (Figure #3) on the rear plate of the camera and cause serious damage. This foreign material must be kept out of the camera working parts, and any future case design should eliminate the condition.

Sensitivity:

This item is a rather difficult requirement to specify and to check in terms of physical qualities; however, if the camera can deliver one volt of video in the vidicon tube when the scene brightness is below 10-foot lamberts and the latest, most sensitive vidicon tube is used, adequate night pictures will probably be obtained. Actual observations of equipment operating at night on the proposed site will be the only true method of indicating whether all of the circuits have been properly designed to give the best night pictures. Several cameras produced good pictures in the project area with a scene brightness of less than 2 foot lamberts. This night picture was only available if lens with an aperture opening of greater than F2.5 were used. Night visibility is not entirely due to sensitivity alone. Oncoming headlights can affect automatic gain controls in the camera which can materially reduce seeability. Other characteristics such as gamma correction, types of lens, etc.

influence the total picture and are discussed as follows.

Automatic Target Control:

In several tests on the freeway, it was determined that automatic target control was an absolute necessity for use on a freeway. In the daytime a picture with scene brightness of approximately 5,000 foot lamberts exists and at night this light will be less than 2 foot lamberts. The automatic target control actually varies the gain or output of the vidicon tube, depending on the brightness of the picture. Without this operation during the daytime, an operator would have to change the aperture of the camera lens or manually regulate the gain control every time the sun went behind a cloud or a shadow fell on the picture area. If the camera was set for a good picture on dull days, the picture would be overly bright and smeared when the sun came out. During the daytime, the picture brightness can vary from 5,000 foot lamberts to as low as 100. At nighttime, however, it is possible that the automatic target control can be a liability. The overall night level of the area is constant because of street lighting.

Some of the tests made with various manufacturer's cameras showed that cameras with an apparent high resolution and high specifications did not necessarily give the best night picture. In fact, one of the poorest night pictures observed had a camera which claimed 2,000 to 1 automatic target control and 600 lines of resolution. As a result of these observations, it was determined that the automatic target control might be actually reducing the overall picture

Sensitivity at night. If the automatic target control circuit is sensitive enough to react to the light received from a few headlights, it could cut the overall sensitivity down reducing visibility to balls of light from the headlights. Since the headlights are moving, no harm seems to be obtained if the sensitivity of the camera can be kept at a maximum at night and allow the image of the headlight to smear. As a result specifications were written so that the camera be provided with a switch which would remotely disable the automatic target control circuit for nighttime operation. This should be provided in any future project because of the great variation observed in nighttime operation of the various cameras. A camera was provided with a switch to turn off the automatic target control at night. The camera was operated with ATC at night producing a good picture and no noticeable difference could be determined when the ATC was turned off. The particular automatic target control circuit used apparently makes use of the average light available to the vidicon and not to the light available in a small area as from a headlight. At the present time there is no means of switching off the automatic target control at night.

Gamma Correction:

Gamma correction is the characteristic installed as a special circuit which expands or increases the ratio between bright and dark objects. Generally, the output from a camera pickup tube would produce a flat or dead picture. In other words, the dark or blacks and white or light colors would all appear in various ranges of gray. The gamma correction circuit is

actually an expansion circuit that makes the lighter colors whiter and the darker colors blacker and in reality returns the picture to nearer its original range of color. At nighttime, there is not a normal range in color between black and white. All of the area has a very small range between the different shades of gray. Multiplying or amplifying this range of color would not normally be observable to the average person. However, the brightness of the headlights is many times brighter or whiter than any other part of the picture. To amplify this range, only amplifies the problem cause by the headlights. In going over the specifications of the various cameras, some successful and some not, it appeared that the gamma correction circuits might have an effect on reducing night visibility. As a result of these observations, it was determined that the cameras should be supplied with facilities to change gamma correction and materially flatten the ratio of the brights to the dark. It was believed that this reduction would be advantageous at night, and would not materially reduce the picture quality in the daytime. After the cameras were delivered, one camera was wired by the factory and made available for trial making use of a lower gamma factor and which theoretically would produce better night pictures. On the General Electric camera used, however, no noticeable difference was determined and it was again converted to standard operation. A change of gamma correction in the cameras used involves only a change of one resistor and one condenser and does not take long to accomplish. This item should be observed on any camera before it is delivered

since it might still be possible that a camera constructed of a different circuitry might be improved with a change in gamma correction.

Aperture Correction:

Aperture correction is another term which adds to the confusion of the myriad of new terms confronting the prospective purchaser. This feature, which can be easily confused with aperture control of the lens, is actually a camera circuit used to accentuate changes in the output of the vidicon tube.

The image formed on the face of the vidicon by the lens is $3/4$ inches wide and $1/4$ inch high. The video intelligence is taken from this image by a process similar but in reverse to the method of producing the picture at the monitor. A beam of electrons are directed at the back of the vidicon face which is also a photoconductor layer and as this small beam sweeps the picture, the current varies proportionately to the light on this particular section of the image.

Since the beam also sweeps this picture in 525 lines, it can be seen that the size of the beam must be very small if high resolution is obtained. Actually, the size of the electron beam cannot be infinitely small and the output is not perfect as desired. A camera producing 600 lines horizontal should be able to reproduce the image of a picket fence with 600 slats shown on the $3/4$ inch width. If the electron beam was infinitely small, the voltage output would vary in amplitude exactly as the light change of the pickets on it would form a square wave.



Actually, the beam has dimension and as it sweeps from light to dark light level, the output changes gradually and the resultant output wave is rounded in shape.



Aperture correction is an electronic circuit which reshapes the wave and squares it to the desired shape.

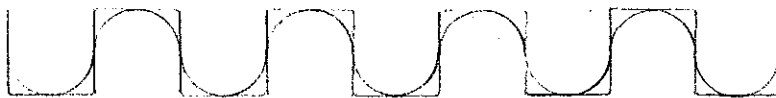

The resultant output is a sharper picture and if resolution exceeding 400 lines is desired, such circuitry is required.

Camera Accessories

Automatic Light Control:

Automatic target control as specified earlier is capable of reducing the output of the vidicon tube to levels which can be handled by the subsequent amplifier circuits. However, in order to obtain good nighttime pictures, the lens used must be opened to F2.5 or greater. No camera was found capable of automatically adjusting to the complete range of light from night to bright sunlight with the lens wide open. There is also a possible danger that the vidicon could be permanently damaged if the lens was opened to F2.5 or greater and happened to focus on a reflection of bright sunlight from a parked vehicle or other reflective surfaces. Observations would indicate that ideal pictures during the daytime are obtained on most cameras if the lens are set between F8 or F11. The specifications were, therefore, written to require that a lens aperture change should be accomplished by remote iris control of at least two lens in a turret or that the introduction of a neutral density filter should be accomplished. Several cameras studied were available with a neutral density filter which could be rotated between the lens and the vidicon tube and reduce the amount of light available to the camera. This appears to be a simple method of reducing the light level by remote control or in the case of some equipment, this filter control was connected to a light cell at the camera site. The cameras on the project use an iris drive

motor which is contained in the small camera package.

As the lens rotates on the turret, it engages a small gear connected to the iris drive motor. This motor, which is remotely controlled from the Control Center, allows the operator to change the iris on any lens which is being used. Iris control does provide the most flexibility of any system that was demonstrated. It is now possible to install four lens on the camera and be able to switch from one lens to another and to close or open the iris as necessary for night or daytime operation.

Normally, only two lens are used on a camera. It would have also been possible to use four lens in a turret, two of which were set for nighttime operation and two of which were set for daytime operation. While this method satisfies most conditions, it would not allow optimum settings during cloudy days or dusk, and it would not give a blank position now used to blank out the vidicon tube when the camera is not in use. Blanking out of the vidicon tube seems to be mandatory in the use of closed circuit television. Other agencies have had problems with images actually burning on the screen. This results in the camera transmitting a picture that it has seen for a period of time even when it is not directed at the scene. The problem only results if a camera is permanently stationed and looks at a target for a considerable time. Since it is possible to change the camera scene by remote turret control, this is not a problem in this particular case.

Lens:

One of the first problems presented in the choice of camera equipment was the selection of lens to be used in observing traffic operations. A most interesting device having a lot of appeal is the zoom lens which is presently available from several lens manufacturers. This lens is capable of showing a general picture with a standard lens view as would normally result from a regular lens on a camera and of "zooming in," on a particular target by remote control for a closeup at the desire of an operator. While one particular zoom lens is available at an F2.7 rating, this aperture setting is only available when the lens is in its normal setting. As the setting is changed to a zoom position or closeup position, the aperture setting is reduced to F5 or F6 which means that it would obtain no pictures at all during nighttime operation. The inability of the zoom lens to handle low light conditions, in telephoto position, ruled out this device.

After considerable investigation, it was found that lenses were available in a telephoto type down to F2.3 or actually F2.0. At the present time one inch or 25mm lens at F1.5 are used throughout the project. This provides a consistent normal field of view from each bridge and gives the operator a standard field for estimating velocity and travel times of vehicles through the area. A telephoto lens of 6-inch or 150mm for closeups of an actual occurrence that the operator wishes to investigate is also used. This lens is a F2 and is of considerable size in relation to the camera. (See Figure 7). These lenses were originally delivered with click stops for

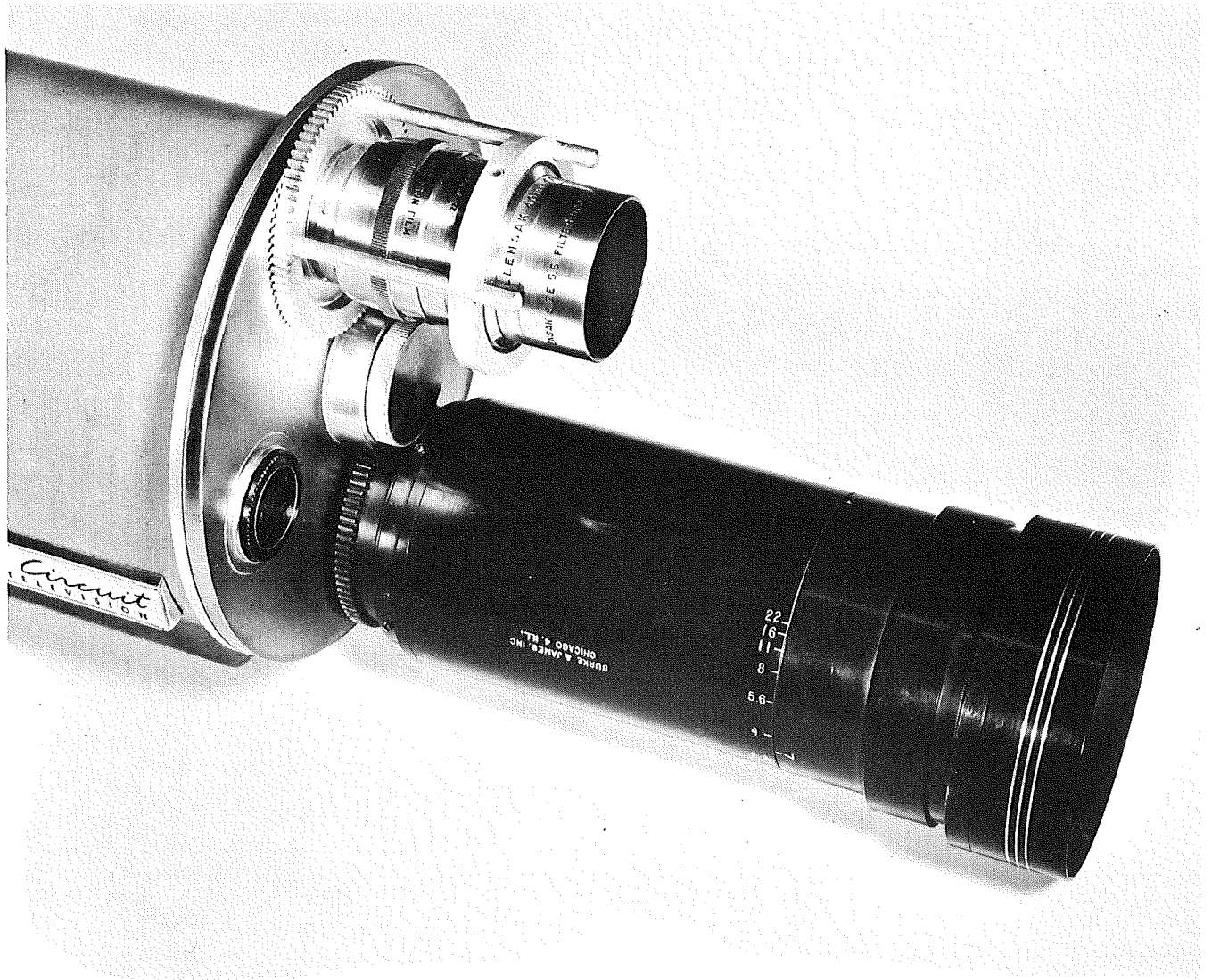

Figure #7

Typical lens used for viewing traffic. The large 150mm telephoto lens is used for closeup viewing. The 5mm lens is used for general wide angle viewing.

different F stop settings but had to be exchanged for lens without any resistance to a change in F rating for smoother operation. The present arrangement of lens in a four lens turret with remote iris control of each lens is very satisfactory. It may be possible that if the field view is a longer distance, an additional nine or ten inch lens could be installed for daytime operation as a third lens. A lens larger than 6-inch was not available with an aperture rating of greater than F2.5 and therefore would not make nighttime operation practical. Even if such lens is available, it probably will be so large that it will not lend itself to operation in a turret with other lenses. The present six-inch lens is approximately eight inches long and weights approximately 4 pounds. Telephoto lens of greater capabilities are available but aperture openings are smaller.

Remote Focus:

Each camera is equipped with a self contained motor and remote focus mechanism which moves the vidicon tube backwards and forwards until it is in focus with the particular lens that is being used. This, of course, is a necessity since a change in lens is accompanied by a change in focal length. Limit switches are provided in the camera to keep the focus drive assembly from overtravel and jamming. Experience with this mechanism has been good with few failures.

Remote Turret:

Since only two lenses were deemed necessary for this project, the specification required a minimum of a three position turret. The camera supplied has a four position turret, one blank position should always be provided which can be capped to

remove light from the vidicon tube when the camera is not in use. Power to the camera is left on at all times. However, when it is not being used, the vidicon tube is capped so that the light is cut off and it can rejuvenate itself.

The turret is required to index accurately to a positive detent from a remote control panel. The camera has this motor inside of the camera package which makes a neat, easily serviced unit. The entire camera, complete with lens turret, remote iris control, and remote focus, is complete in one small package and can be replaced with a spare camera in a matter of minutes.

Pan and Tilt Assembly:

In order to make proper use of the telephoto lens which has a very small field of view, a pan and tilt assembly is mandatory. Probably no other manual control receives more operation during the day than the pan and tilt assembly on each camera. This makes it possible to scrutinize any activity within the field of view by the use of the telephoto lens. Since choice of camera sites made it possible for all areas to be viewed within a 60-degree area, a cabinet housing was designed so that the pan and tilt assembly would operate inside of the housing. (See Figure 8). By using the pan and tilt assembly inside of the camera housing, a standard light weight pan and tilt assembly which was protected from ice, snow and vandalism, could be used. Other camera locations might make a greater field of view necessary in which case a smaller camera housing would be used and the entire housing would be



Figure #8

Camera mounted on pan and tilt assembly in field housing.

operated by a pan and tilt assembly. A pan and tilt assembly which operates the entire camera enclosure is more heavily constructed and cannot be entirely protected from all types of vandalism. Either the entire enclosure area must then be fenced off or the camera mounted on top of a building or on top of a pole in such a way that it cannot be readily reached by unauthorized personnel.

The use of a pan and tilt assembly has an additional advantage which was not considered at the time of the writing of the specification but it has increased the usable life of the vidicon tube by several times. As previously mentioned, a camera which looks at the same scene all of the time soon has an image burned into the photo-conductive layer of the vidicon tube and the picture is transmitted no matter where the camera is aimed afterwards. Since the pan and tilt assembly is used many times a day by the operator, a picture is not burned into the camera tube and, therefore, is not a problem. The pan and tilt assembly is equipped with limit switches so that the camera can pan 30 degrees to the right or 30 degrees to the left and 30 degrees below horizontal. These limit switches automatically stop the pan or tilt movement at these points so that the lens does not hit upon the sides of the cabinet.

Camera Enclosure

Housing:

The camera housing specifications were developed around the two drawings shown in figures 9 and 10. Since many bridges that cross over a freeway system are not at right angles to the freeway, the housing was designed in two sections so that the upper section could be rotated and allow the camera to be oriented with the freeway below. While the basic design has proven to be a good one, many of the changes or incorporations made by the manufacturer have not proven to be entirely satisfactory. The lower cabinet was made considerably larger than originally specified at the request of Michigan Bell Telephone Company who obtained the low bid contract for supplying the transmission facilities. The specification required certain temperature limitations which were to be met and the design was to incorporate enough heating and ventilation to maintain these temperatures under all weather conditions. Due to the short length of time given to the contractor after the awarding of the contract before the final installation was to be completed, a very limited amount of design work went into the cabinet by the manufacturer. Actually, the local sales representative worked with a metal fabrication shop and settled on a design which left something to be desired. A considerable amount of money was spent rebuilding the cabinet heating and ventilating facilities to meet specifications. The cabinet housing was finally insulated and heaters installed in both upper and lower sections.

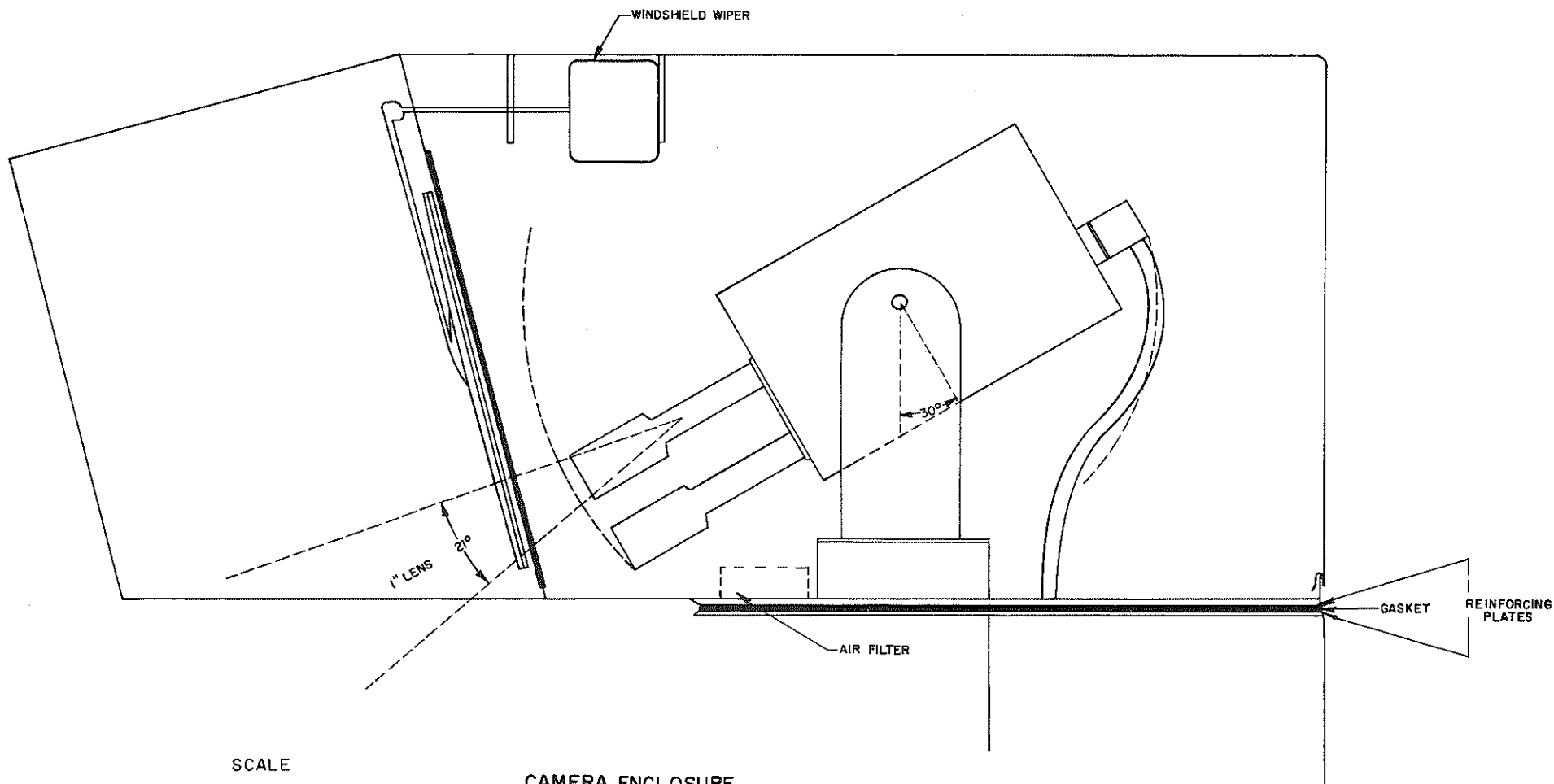

SCALE



CAMERA ENCLOSURE

SIDE VIEW

FIGURE 9

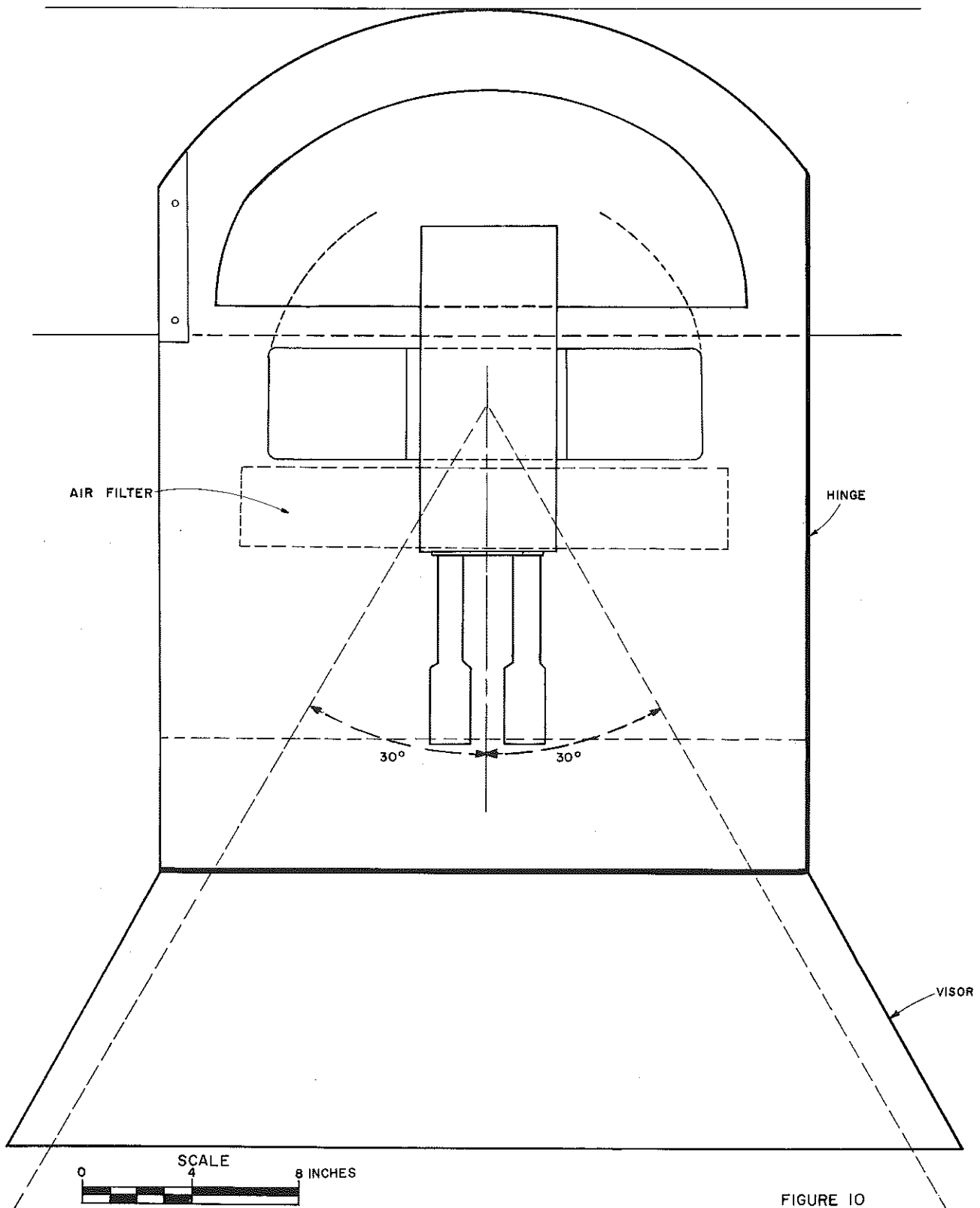

AIR FILTER

HINGE

VISOR

30°

30°

SCALE



FIGURE 10

CAMERA ENCLOSURE

TOP VIEW

The existing cabinet has proven to meet all requirements from the standpoint of vandalism and operation.

One of the problems now encountered with the present cabinet is that the design with special flanges (see figures 11-14) prohibits anyone from reaching the face of the glass through which the camera operates. While this design has done a very good job of keeping any vandalism from occurring, it has also made it impossible to reach and clean the outside of the glass. Windshield washers were not installed in the original installation because it would still be necessary to refill them on a schedule and it was felt that the normal preventative maintenance routine would also allow for the periodic cleaning of the glass. No great problems occurred with dirty windshields since they do not seem to get too dirty in a period of one month, and if an occasional splatter of rain gets on the glass, the windshield wiper wipes it clean. At the present time, the maintenance personnel have a large tank sprayer with a long, bent nozzle which will reach out over the cabinet and squirt cleaning fluid on the face of the glass. The windshield wipers seem to do a satisfactory job of cleaning the glass. A more desirable design would allow for easier access to both sides of the glass.

The final upper housing was constructed of heavy 10 gauge steel and consisted of three access doors. This allows both sides and the top to be opened for easy access to the interior. In actual use, the top opening has never been used. The two sides open up and have provided adequate working area. Because of the weight problem, it might be



Figure #11

Field housing containing camera and related field equipment as viewed from shoulder of freeway.

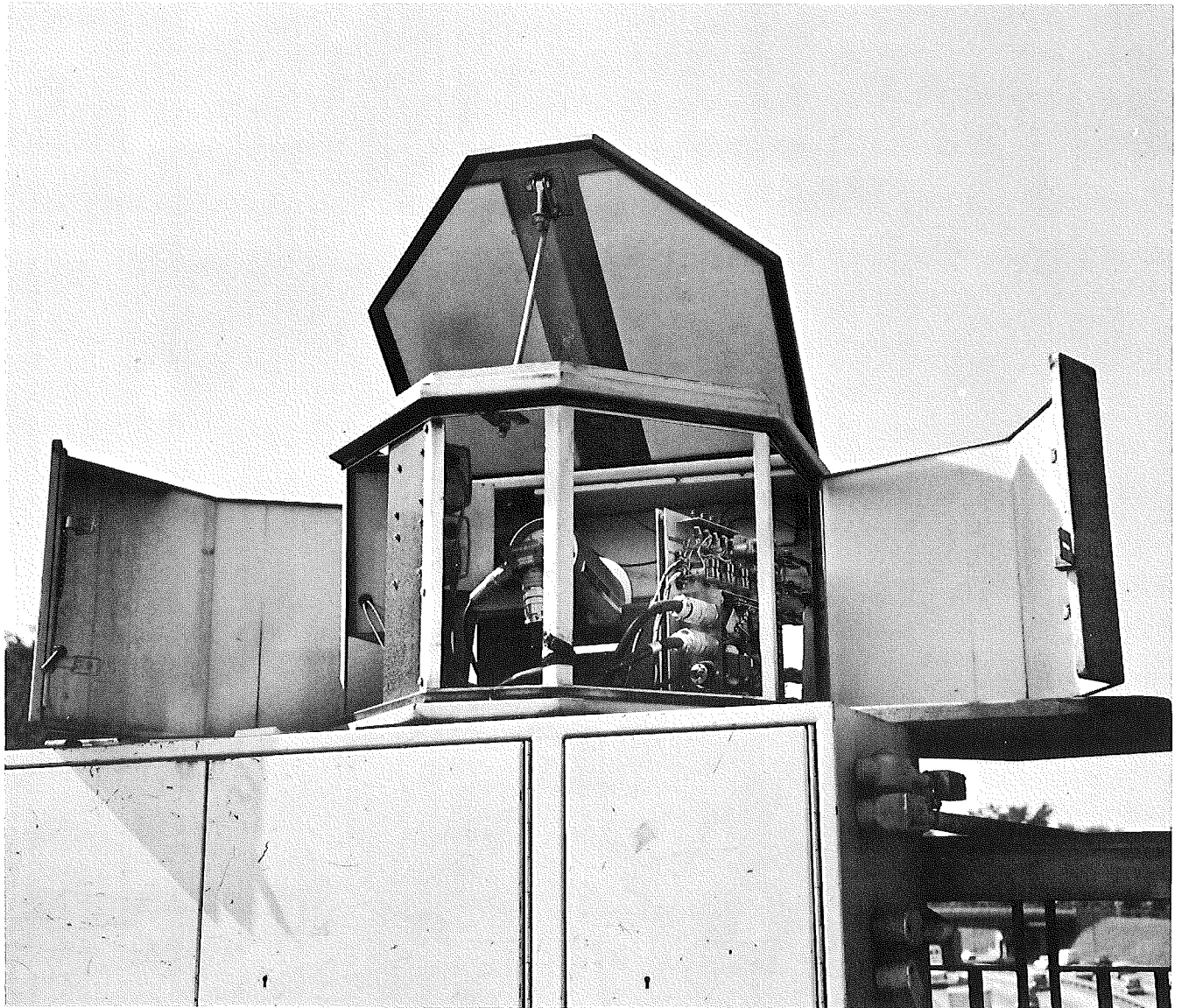

Figure #12

View of camera housing showing upper housing opened
for access to cameras, etc.

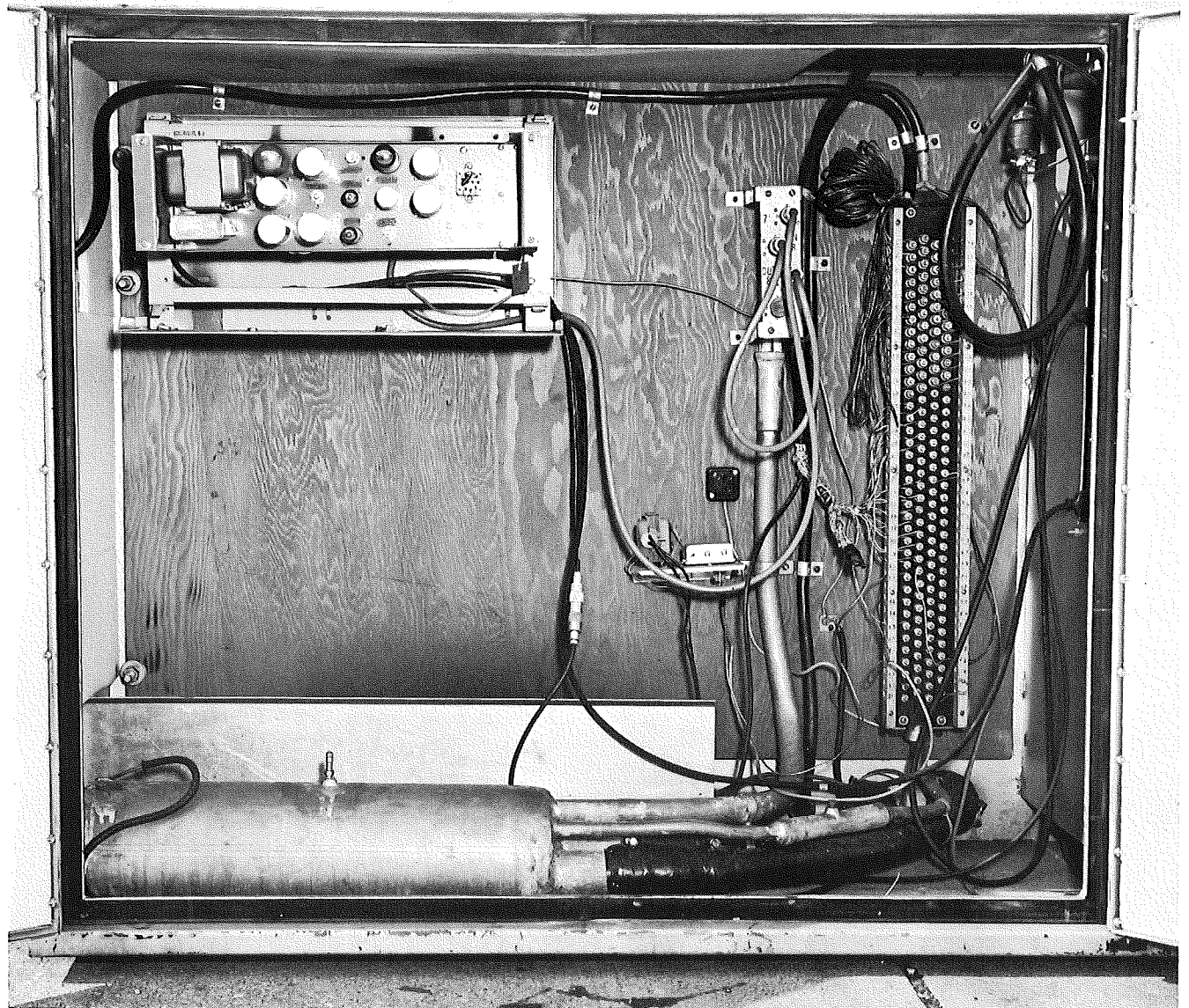

Figure #13

View of left side of lower camera housing with doors opened showing video cable splice, video amplifier, and control terminal board.

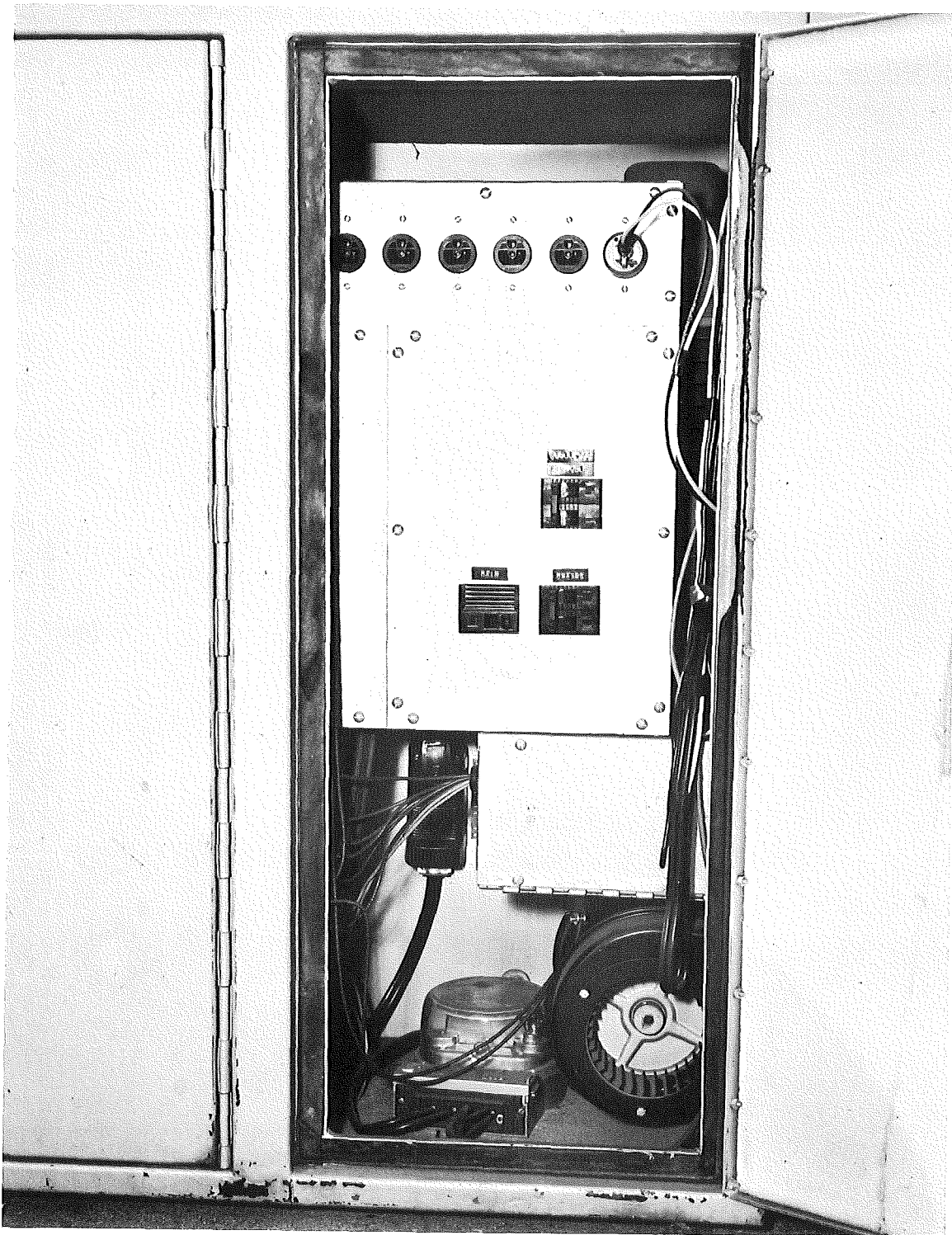

Figure #14

View of right side of lower camera housing with door open. Shows transformer, ventilation equipment, circuit breakers, and 115 volt field supply for maintenance.

desirable that the cabinet be designed with aluminum of about the same gauge which should be strong enough to repel vandalism but which might be light enough to allow the top to swivel if properly designed gasket material was used.

It has become apparent that if the cameras are to operate all the time, that heating within the limits specified would not be necessary. The amplifiers provided by the Michigan Bell Telephone Company consist of vacuum tubes which operate 24 hours a day. In their experience they did not feel that heat was necessary in the lower part of the cabinet so that it now seems that the upper cabinet should have been heated and ventilated by smaller units in itself and that the limits of heating should have been much broader. As long as the camera is operated 24 hours a day, it does not appear that the upper cabinet would have to be heated until the temperatures in the cabinet dropped below freezing. The bottom cabinet requires considerable amount of ventilation because of the heat given off by the amplifiers and the power of the isolation transformer. The large amount of circulation required to remove this heat is presently taken in through the upper housing. This means that a much larger volume of dirt, silt, and salt are passed by the camera and has been responsible for some problems. A future design could separate the two cabinets with two separate ventilating fans and should reduce part of the dirt problem in the upper housing.

Specifications required that the hinged door should permit complete access to the interior of the lower housing. When closed, the door was to fit closely to the gasketing

material making the housing weather tight and dust tight. The door was to be adequately reinforced and supported so that it could not be pried open with simple tools. The requirements also stated that an adequate locking system should be provided and all locks should be keyed alike. The original lock system devised was a lever lock which operated bolts to lock both the top and the bottom of each door. This device was then locked with a Corbin type lock into which the key was inserted through a small hole cut in the door. The handles used to unlatch the door were large enough so that vandals could actually twist the mechanism and damage it when it was locked. Therefore, all the handles had to be changed to a much heavier type. Since that time, all of the handles have been padlocked with a standard hardened padlock as used by many power companies and no serious problems have occurred.

Windshield Wipers:

All of the housings are equipped with windshield wipers. At installation, all of the windshield wipers were turned on at the same time and turned off at the same time. However, the design of the housings with the extremely large visors has proved to be highly effective and the windshield wipers are only used to wash the windshields or in extreme weather conditions. It has been observed that even then only one or two of the cameras which face a particular direction receive any precipitation on the window glass and need the windshield wiper. Because of the very limited use made of the windshield

wipers, the control was rewired so that the operator can operate just the windshield wiper that is required.

The windshield wiper was designed by the company who designed the cabinet. The windshield wiper blade remains vertical and is attached to a dual thread screw which runs the wiper back and forth across the glass. The operation is very similar to a level-wind casting rod reel and seems to work satisfactorily. The resulting size, however, was rather surprising since the manufacturer chose to use a one quarter hp electric motor to operate this drive. In spite of the size of these motors, motor burnouts are still a problem and the entire design of the windshield wiper system should receive considerable more attention. It is very possible that the visor could be lengthened or redesigned and that it would be unnecessary to have a windshield wiper at all.

Heating:

As mentioned under housing, heating was one of the major problems confronting the contractor. This item should have been tried and conducted under research conditions using a cold room. Instead, it was assumed that the installation of a 1000-watt heating strip in the bottom of the cabinet would suffice. The equipment was installed in mid-winter. When the heating system was checked out, it was found to not be heating the upper cabinet properly. The electric heating strip did not force circulation throughout the cabinet and during extremely cold weather had very little effect on the temperatures in the upper cabinet. Finally, a 750 watt bathroom type electric heater with a fan was installed in the upper cabinet.

It had more than enough capacity to solve the upper cabinet temperature problems, and is the only heater now being used. The contractor also insulated all the cabinets with one inch of styrofoam to further reduce the heating problem. Temperature recording devices are now being used to determine minimum heating requirements for these cabinets.

Ventilation:

A large double ended centrifugal blower is thermostatically controlled to exhaust air from the cabinets. Fresh air is brought in through a filter in the upper enclosure. This fan has been capable of adequately cooling the cabinet although for some unknown reason a difference in cooling capabilities between cabinets is obtained.

Remote Control System

Field Relay Panel:

Probably no single item received less attention at the time of design and installation of the system but caused more trouble than the remote control relays. In order to control all of the many functions from the Control Center, a system of low current relays were required. The Company designed and constructed a standard relay panel which was installed in each camera enclosure. Since the project area has 150 pair of control wires available, the control system was relatively simple electrically. A separate wire is used throughout the system for each control function and a separate wire is used for each location.

The basic concept of the control has proven to be adequate, however, the relay panel at each field enclosure has been a major problem. Small, standard, open relays were mounted on a heavy sheet of brass stock and installed in the upper housing along with the camera. It was only a matter of a few days until trouble occurred from these relays. The major problem was caused again by the fine salt spray which had settled throughout the cabinet. The contacts would become fouled and the circuit would not work. At the time the specifications for the camera were written, the control seemed such a small part that very little design effort was placed upon it. Since that time, a remote control system for the lane control signals was installed throughout the project. This system used heavy duty plug-in

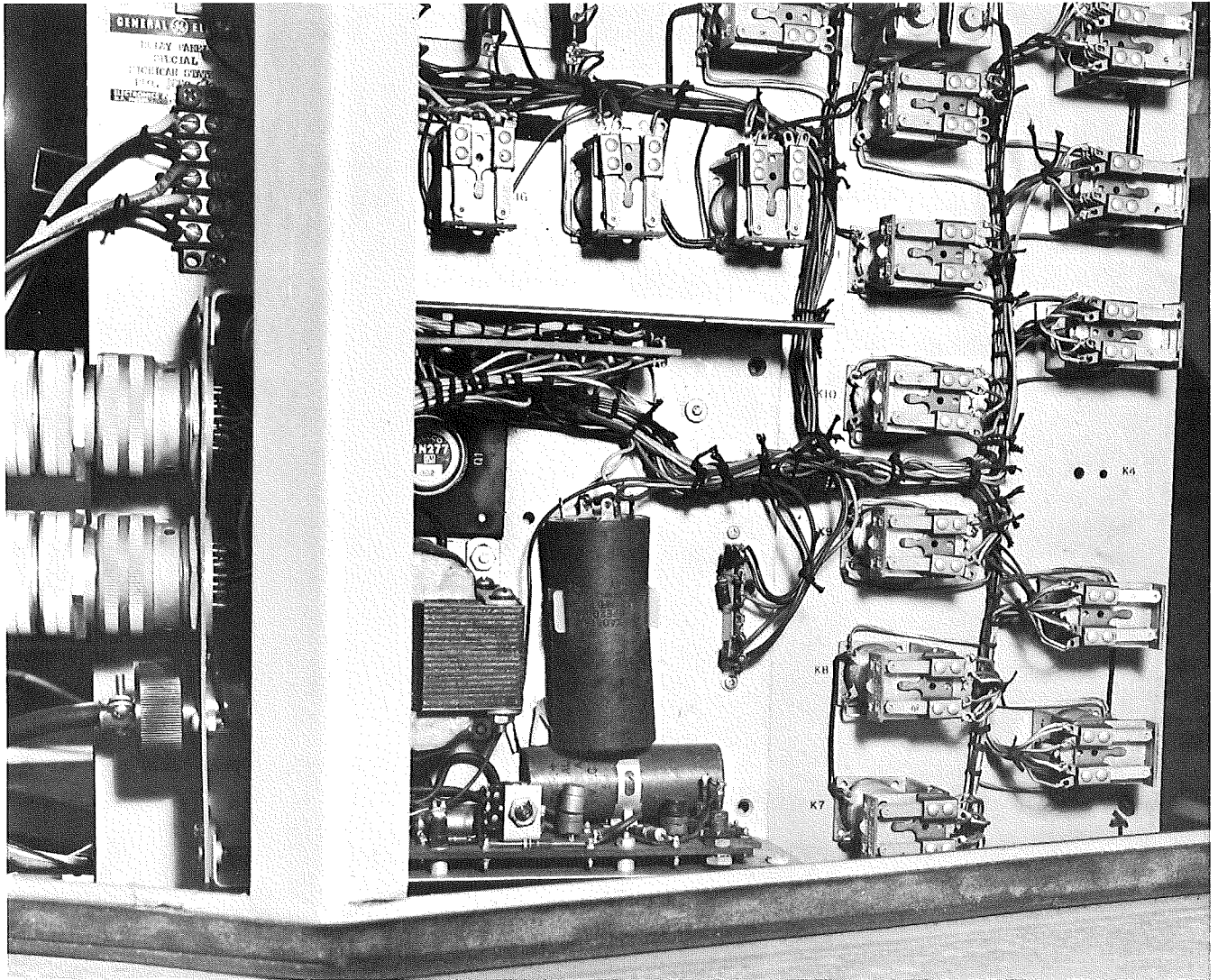

Figure #15

Actual view of field installation of control panel,
showing exposed relays.

type relays and were enclosed in a dust tight cabinet. Any future control system for cameras should also specify that relays be of the plug-in type in self enclosed containers and that the entire relay panel should be enclosed in a dust tight enclosure.

Control Panel:

The control panel in the Control Center which is used to remotely control all of the accessories in the field is in one compact console (See Figure 16). The bottom row of buttons is used to select a particular camera for which the control is desired. The pressing of this button connects all of the relays at that particular camera site to the control lines. The middle row of lever type switches is used to control the various functions. These switches are spring loaded and return to their neutral position when they are released. This principal of control has proven satisfactory although the particular switches chosen for selecting the various stations have not proven to be overly reliable. A heavier duty type of gang switch would be more desirable.

The top row of buttons are used to operate the video switcher. The pressing of any one of these buttons will automatically switch the incoming signal from that particular camera to an extra or 15th monitor. Pressing the button to the far right will set the video switcher into automatic operation. These functions will be explained under Video Switcher. The two speakers located in the panel were designed to allow radio communication with any one of the camera

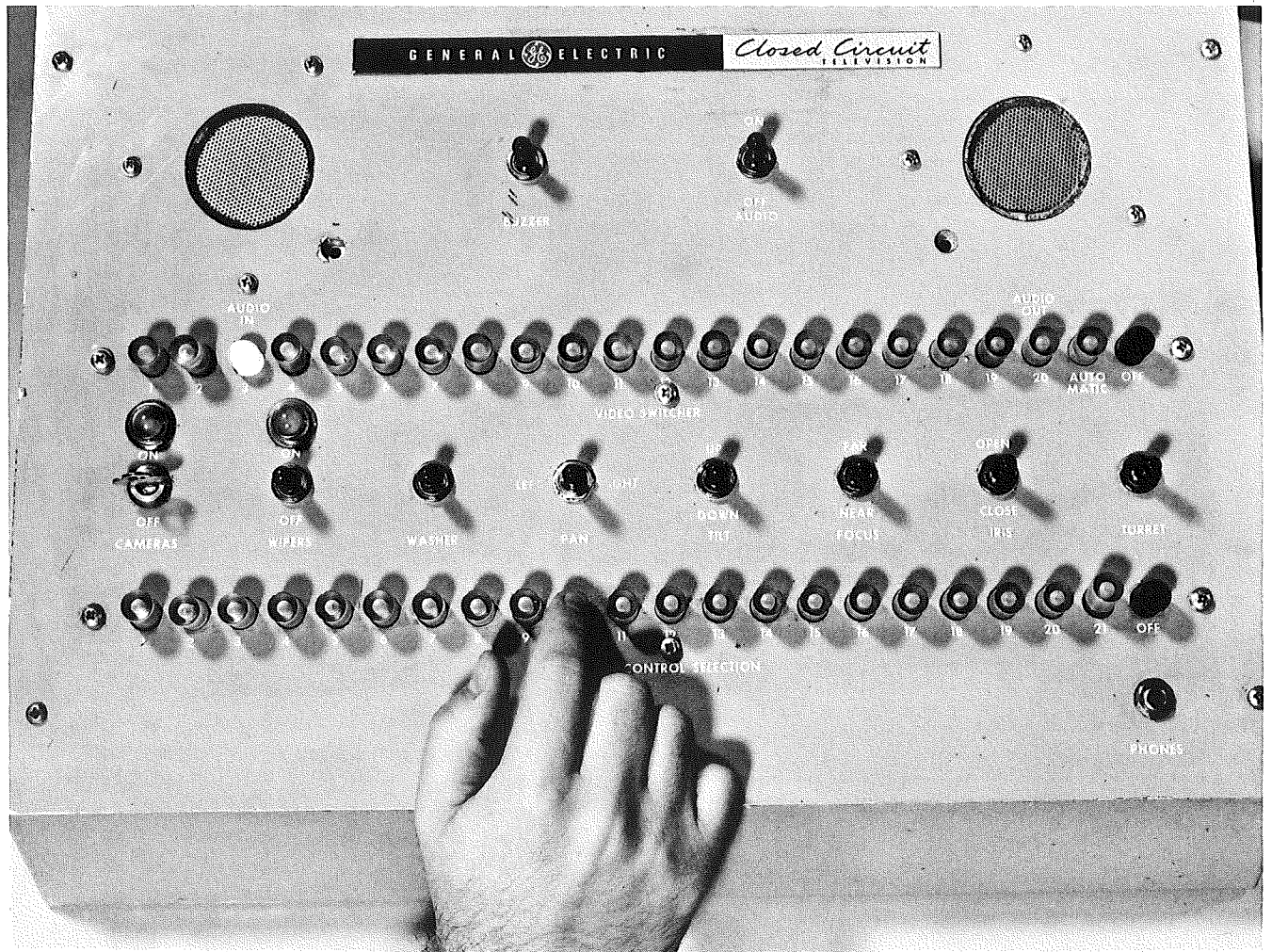

Figure #16

Camera Accessories Control Console. Bottom row of buttons select camera and middle row controls each separate function. The top row of buttons control video switcher to switch any one of 14 pictures to a spare monitor.

enclosures. A buzzer is located in each cabinet and by pressing one of the buttons on the control panel, the buzzer can be rung and attract the attention of a maintenance man working in the area. By plugging in his sound powered earphones, he can communicate with the Control Center. This system has worked off and on, and while it is working, has proven to be very desirable. For some reason, we still have some hum in the lines, due to the combination of sound-power telephones and amplifiers. This, too, was such a minor part of the overall system that it received little or no attention during the installation.

Video Switcher:

A video switcher (Figure 17) was included in the specifications and installed in the Control Center. As pointed out earlier, it allows an operator to select the incoming video signal from a particular camera and switch it to an extra, or 15th monitor. This switch can be made in the event of the failure of any one of the monitors, or for study purposes. A study group can move this monitor to any location in the Control Center and study the output of any one of the cameras without interfering with the normal operation. This feature has proven very desirable and has been used many times. Besides being used to study a particular traffic problem, the monitor is located near the counting and detector computer panels and allows an operator to check the efficiency of the counting equipment. A camera can be selected which actually shows the vehicles passing under a particular detector so that the accuracy of the computer equipment can be observed directly. This feature

alone has proven invaluable many times in the checking and comparison of various counting equipment. The ability to switch an incoming video picture to an out-going circuit has also been used to transmit a particular picture through the Bell System to another location. On two different occasions a picture was transmitted to downtown Detroit over 4 miles away.

A second feature of the video switcher used in the Control Center is the ability to automatically switch from one incoming camera signal to another sequentially at a fixed time rate. This switching is motor driven and can be adjusted for different time intervals. At the time of installation, there was considerable conjecture as to the need of a separate monitor for each location. Most of the previous plans for traffic surveillance were on the basis that a man can only watch one monitor and that the incoming signal could be switched from camera to camera and provide the necessary control. Another reason for considering such type of operation has been in the cost of installation. Considerable savings can be obtained by switching one camera at a time. It would be necessary to have only one cable run the entire length of the system and the switching would be accomplished in the field at the camera. This would reduce the cost of the transmission considerably, especially if the distances were great.

At the time the specifications were written, no company would guarantee to provide a switching operation in which the successive pictures would form on the monitor without flip-flop. Since each of the cameras has its own synchronizing

generator, the different pictures received from the different cameras would actually not be perfectly in step unless some master synchronizing signal was transmitted to each camera. This type of synchronization is complex and very costly and was not considered necessary since the decision was made to utilize individual monitors for each camera.

Several research studies which were programmed would not be possible without individual monitors for each camera location. The securing of vehicle travel information through the study area was not possible with sequential viewing, nor does it lend itself to following happenings covering several camera views such as stoppage waves. In actual practice it has been found that the sequential switching operation is very satisfactory with our present camera and monitor. Most of the success is due to the very good synchronizing ability of the monitors used. The monitor is capable of synchronizing itself immediately to any incoming signal and the resultant change between pictures does not have any roll or flip-flop. This feature has amazed nearly every television engineer that has seen it operate.

While experience has shown that the bank of monitors (one per camera) is very superior to the sequential method, the possible difference in installation cost will still require that a study be performed to find the limitations of a sequential system.

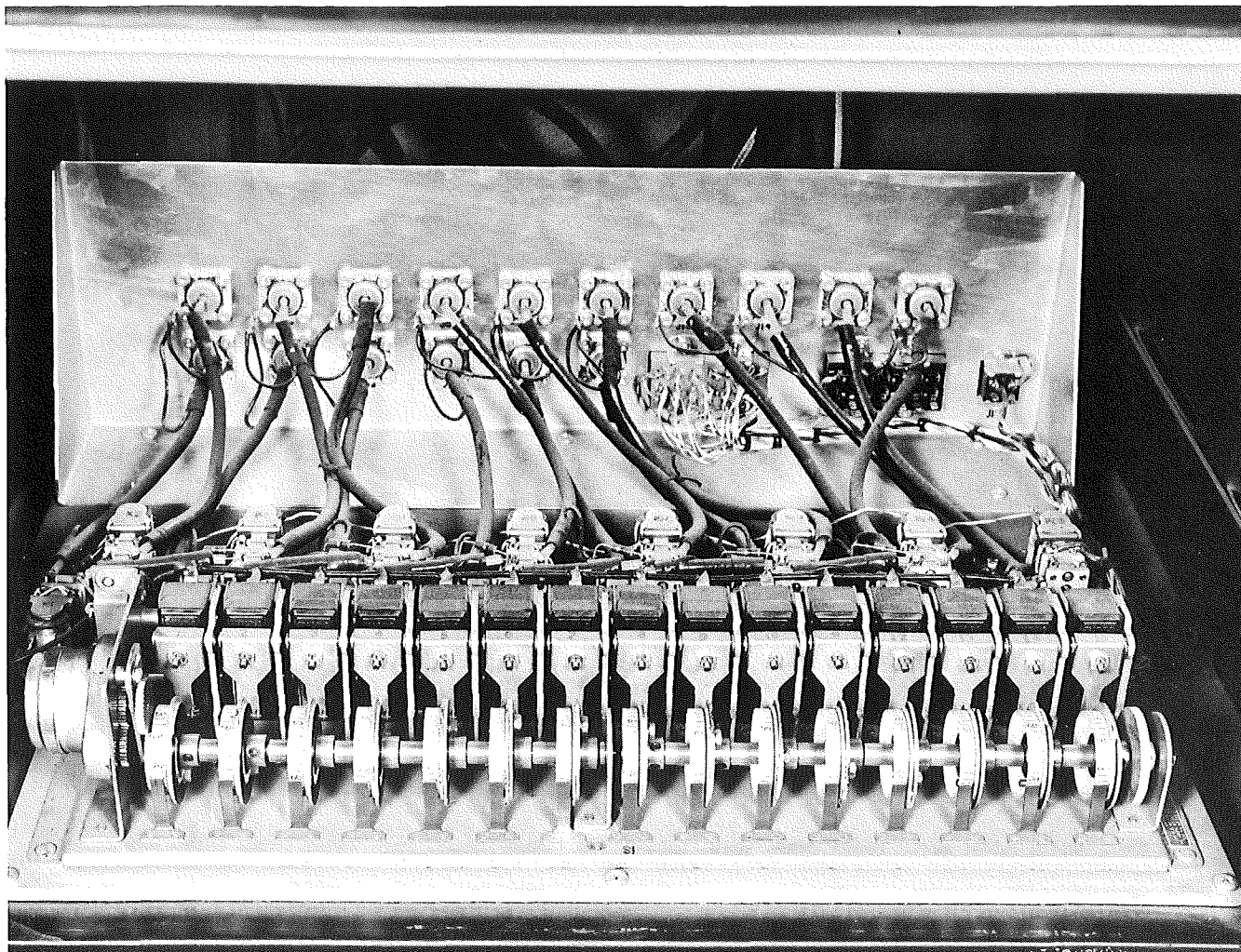

Figure #17

Closeup view of video switcher.

Monitors

A monitor is the closed circuit equivalent to a television receiver. In general, it has the same circuits as a television receiver without the tuning system or sound system. It does not necessarily mean that it is more economical since the synchronizing circuits and oscillator circuits are more refined and stable. Actually, this monitor has about the same tubes as the commercial television sets, irrespective of their additional circuits. The cost of the monitor is about \$400.00.

The closed circuit television buyer has a large range of monitors available. There is a choice between 8 inch, 14 inch and 17 inch screens in the higher quality monitors. Generally, the most used are either the 14 or 17 inch sizes. The 8 inch size is used for portable operation at a camera site for maintenance purposes. While the 14 inch monitor could be mounted in certain conditions more closely together, the normal mounting is in the standard 19 inch radio racks. These racks are commercially available from several manufacturers and provide a pleasing arrangement at a minimum of cost. Since these racks are of a standard size, the 17 inch monitor will fit in the same rack that a 14 inch monitor will fit. This means that the spacing between the screens will actually be greater on the 14 inch size and for general application the 17 inch monitor would be the best buy. Special 21 inch monitors are also available but are generally for classroom use and will not fit into the standard radio

racks. Generally the 21 inch monitors are not of the same high quality design that is available in the 14 or 17 inch. The monitor used for this project was a new development, and was by far the best monitor seen in operation.

As stated under the section of random and positive interlace, one of the major problems noted in many monitors was a tendency to pair subsequent sweeps and therefore nullify the advantage of interlace sweeping. This monitor was never troubled with pairing or synchronization problems of any sort. As also noted under "Video Switcher", this monitor is capable of operating under sequential programming with present connections without flicker, roll, or flip-flop.

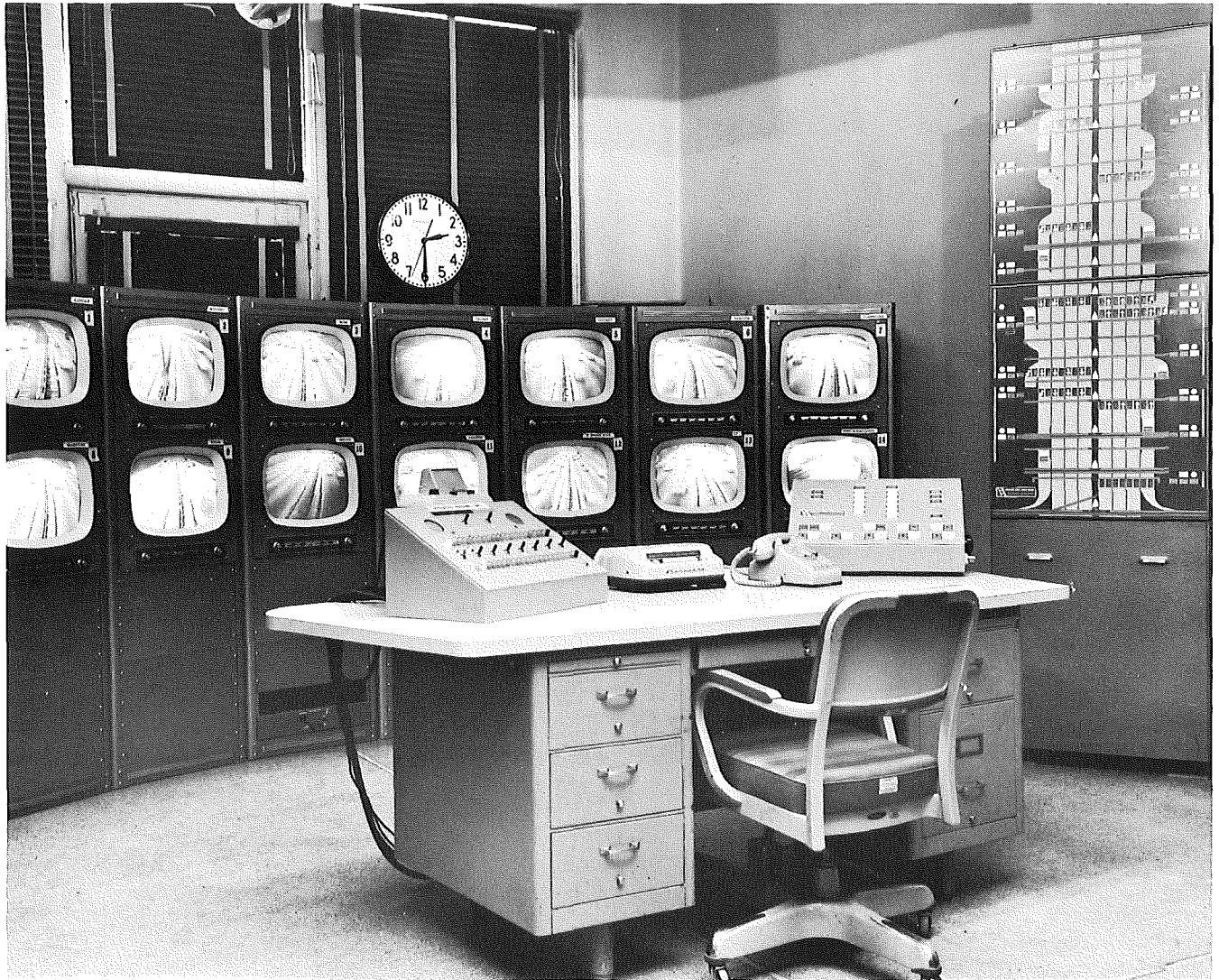

Figure #18

View of Control Room showing control, desk, bank of 14 monitors and confirmation panel for signal control system.



Figure #19

Freeway traffic as viewed on television monitors.

Transmission Systems

General:

Another major item which seldom does not receive proper attention in the original planning stages by the design engineers is the transmission facilities. The technical differences between four different systems which may be purchased and installed by the buyer or leased from various companies will be discussed.

Balanced Line Video Cable:

The term balanced line refers to the cable construction. The cable consists of two conductors twisted together and enclosed in layers of shielding and weatherproof coverings. Balanced line video cable eliminates much of the noise which is normally obtained on long line coaxial cable runs. Noise pickup which would show up in audio systems as static, appears in a video picture as white flecks or spots. Any amount of noise will materially reduce the resolution of the final picture. The balanced line video pair automatically provides suppression of noise generated between the line and shield. Any noise picked up along the cable provides the same positive to negative ratio between the two conductors. Since the two types of signals are developed in different ways, specially designed amplifiers have no trouble sorting the noise from the actual video signal. Balanced line cable costs about the same as high quality coaxial cable and because of its automatic noise limiting characteristics is superior for direct video communication.

The use of balanced line transmission facilities is new in closed circuit television. At the time the specifications were written, only one of the TV manufacturers was even proposing the use of this type of cable. The Telephone Company had been using balanced line transmission facilities for short distances but with a lower band width than this project required. When the specifications were written, only one company could supply an amplifier which could amplify balanced line transmission with a full eight megacycle bandpass. By the time the contract had reached the letting stage, most of the manufacturers were starting to recognize the advantages of this system.

The longest transmission line is 10,000 feet and is producing high resolution picture with no noticeable noise. The Telephone Company has transmitted the video for $4\frac{1}{2}$ miles over parallel lines and again no problems occurred. Since a separate cable is necessary for each video chain and an amplifier is necessary for each mile, radio frequency modulation or micro-wave transmission will be more economical over longer distances. In the control project area, the Control Center is centrally located and most cable runs were short enough so that direct connections by the balanced line video cable not only provided the best picture, but was one of the most economical methods.

Coaxial Cable:

The use of coaxial cable for the use of transmission of any high frequency signal has been in general use for years. It is available in many sizes. The relative difference between

coaxial cables lies in their attenuation or signal loss characteristics. The larger the cable is in diameter, the lower its losses in transmission. Naturally, the larger the cable, the more costly it becomes. The use of coaxial cable has been a standard by the closed circuit television industry and at the time the specifications were written was in general use by most of the manufacturers. Generally, the manufacturers' experiences with long line transmission were not too great. Very few of them had installed any systems over a mile in length. None of them wanted to guarantee a 10,000 foot chain with low noise levels. The coaxial cable has the disadvantage that all noise picked up from the shield develops the same positive to negative ratio of signal level with the center conductor as the signal itself. This means that it becomes difficult to retain a good signal to noise ratio. Certain suppression circuits have been perfected which sample the noise on the shield of the cable, amplify this noise, and run it out of phase on the signal cable. The balanced line pair automatically provides this suppression.

Radio Frequency Modulation:

A third method of transmitting video information from a camera to a monitor would involve the use of radio frequency modulation. A special modulation device is installed at each camera, and the output of each camera modulates a different radio frequency. These frequencies then are transmitted down the same high grade coaxial line to the Control Center.

Demodulation equipment in the control center again sorts the signals apart and provides video to each respective monitor. The advantage of this system is that only one high grade coaxial cable needs to be run to serve several video channels. With the 8 megacycle band width required, one company guaranteed the installation to transmit seven different signals over the same cable. In this case, they would use a very high grade coaxial cable costing approximately twice that which is used for balanced line video.

A manufacturer claims to have operated this modulation system over many miles of closed circuit television. This method should certainly be considered where the length of the transmission would justify the savings in cable. Since a modulator and demodulator is necessary for each chain involved, the additional cost of \$1,000 per chain would only be offset if a considerable distance was involved. The distance would be approximately 2 miles.

It could well be that if an expanded system was installed, the control centers of a maximum size would operate a certain area of freeway and a central control center would be interconnected to each local control center by one cable. The use of modulating equipment would allow several signals to be sent to the central control and provide the overall intelligence necessary for an entire city. If it is determined that it is possible to get along with less resolution or in other words a smaller bandpass, it is possible that 13 channels could be placed on one cable, as claimed by one manufacturer.

Modulated signals on coaxial cable will still have to be amplified about every mile, however, the companies have developed wideband amplifiers which can amplify all channels at the same time.

Micro-Wave Transmission:

A fourth method of transmitting video information is by the use of micro-wave equipment. This method of course is being used for all broadcast work where long range transmission is required. The cost of the equipment for each channel is approximately \$10,000 and would make the transmission over short distances prohibitive. Again the possibility of using such a system to transmit from a small control center to a master control center certainly could justify such equipment. There is a limitation in the number of channels that will be approved by the FCC for this type of operation, which means that it did not lend itself too well to the transmitting of an entire facility simultaneously. It can be very economical for long range transmission in that no intermediate amplifiers are necessary as long as the transmitting and receiving antennas are in sight of each other. When these antennas are located on small towers, the distance transmitted can be several miles. Micro-wave transmission also lends itself for portable setups. Small micro-wave transmitters are available which can be moved to a location in a reasonable short period of time and connected to a camera, so that a camera can be installed and connected to a control center in one day if necessary. In a large, complex system such equipment would provide good auxiliary facilities.

Cable Location:

A completed freeway does not easily lend itself to the installation of additional cables. All lines on surface streets are generally seven hundred feet from the freeway and although the aerial runs on the pole lines can be accomplished economically, the laterals into each bridge can cost nearly as much as a cable run along the freeway by other means. Directly burying the cable along the sides of the freeway involves either tearing up the blacktop shoulders or cutting into the sodded backslope. While either case is possible, it still involves costly runs beneath the entrance and exit ramps. The John C. Lodge Freeway has a continuous raised median throughout the length of the project. This median has a guard rail down the center and is covered with bituminous concrete. Since the cameras were installed on the center of bridges crossing the freeway and directly over the median, the least costly location for the installation of this cable was directly along the median on the surface and attached to the guardrail posts. Since the duration of the project was originally set at only two years, it was not possible to justify spending money for a permanent cable installation, and this location was finally chosen because it was by far the most economical location.

The Michigan Bell Telephone Company submitted a bid for leasing the lines at a very favorable cost. Costs forced the installation of the cable on the surface of the median attached to the guardrail. They had each group of cables specially constructed into one large cable with an extra heavy polyvinyl sheet. An additional feature which was not

specified was added. The cable was pressurized with 9 pounds of dry air to keep out moisture.

While the original duration of the project would allow no other installation, it now appears that a better location would have been justified. Considerable trouble was required to eliminate all leaks in the cable. Damage has been inflicted by vehicles on several different occasions. It appears that the most economical location for this cable would be to install it in duct under the median. The removal of the bituminous concrete would not be costly if a special chipper could be used and the duct work would not have had to be very deep under the surface for protection.

Conclusions:

This report has not been written to provide specifications for a typical closed circuit television system. Specifications would have to be written to consider all factors and conditions for an individual installation. This report has outlined the problems encountered on the John C. Lodge project and justified the reasons for the decisions taken.

There are several items remaining to be studied regarding the use of television for traffic control. This includes the feasibility of sequential operations for reviewing traffic, new and better methods of recording the information from the television picture and determining the best location for camera sites to improve overall visibility of the freeway.

The use of television for traffic work is still in its embryo state. The problem does not seem to be how good it is, but rather how much can be done with it? Its uses for study and control operation are practically limitless. Simultaneous viewing of long sections of the freeway can now be accomplished by one person, under all types of weather conditions at all times. While this is possible over short periods of time from a helicopter, it is possible to watch more areas at once with better detail from television. The location of a central site also makes it possible to install control facilities to change speeds and control lane usage. It allows the installation of detection devices which will record and tell the operator the exact volume and speed conditions of the traffic at the time he is watching it. The relation of all of these things have been nearly impossible until this time. The facility presently used on the John C. Lodge is probably one of the finest traffic research tools yet developed and project personnel can only be enthusiastic of the operation of this system.

APPENDIX A
DEFINITIONS OF TERMS

Resolution:

The ability of a television system to distinguish fine detail in the subject matter.

Definition:

A term used to describe the appearance of sharpness or of being in focus.

Contrast Range:

The ratio of lightest to darkest light level.

Scanning:

Circuitry whereby a beam of electrons scans or sweeps across the image on the camera pickup tube and in effect, divides the image into narrow horizontal strips called lines. These lines are reassembled on the face of the monitor picture tube to produce the image. For each complete picture 525 lines are scanned in present television systems.

Field:

Each group of one half ($262\frac{1}{2}$) of the 525 scanning lines required to produce a picture.

Frame:

Complete group (525) of scanning lines, also called a roster.

Interlaced Scanning:

The scanning beam sweeps the image (down only) in $262\frac{1}{2}$ lines and returns to the top. It then scans the picture again but this second set of lines are interlaced between the first set of lines.

For each complete picture, 525 lines are scanned. Since 30 frames are scanned per second, $525 \times 30 = 15,750$ lines each second.

Non-Interlaced Scanning:

When the beam scans the image horizontally and it reaches the bottom, it returns to the top and the scanning process is repeated. Random interlace occurs when the lines of the second field may fall at random anywhere between the lines of the first field and in some cases on the lines of the first field. If this occurs, it is called "pairing".