

A DETAIL - SQUARE ALUMINUM BASE
N.T.S.

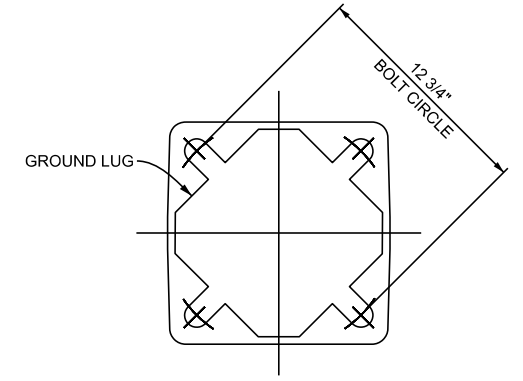

B DETAIL - SQUARE BASE BOTTOM PLAN
N.T.S.

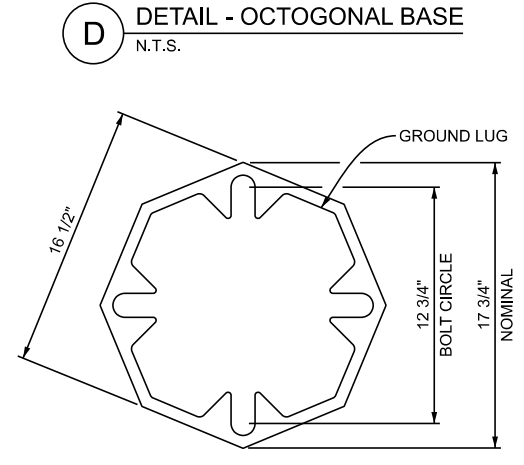

E DETAIL - OCTAGONAL BASE BOTTOM PLAN
N.T.S.



F DETAIL - (OCTOGANAL BASE)
N.T.S.

G DETAIL - (SQUARE BASE)
N.T.S.

NOTE:
USE PEDESTAL COLLAR FOR PEDESTAL LENGTH GREATER THAN OR EQUAL TO 14' (TYPICAL FOR 3 COLOR TRAFFIC SIGNALS WITH PEDESTRIAN SIGNALS).

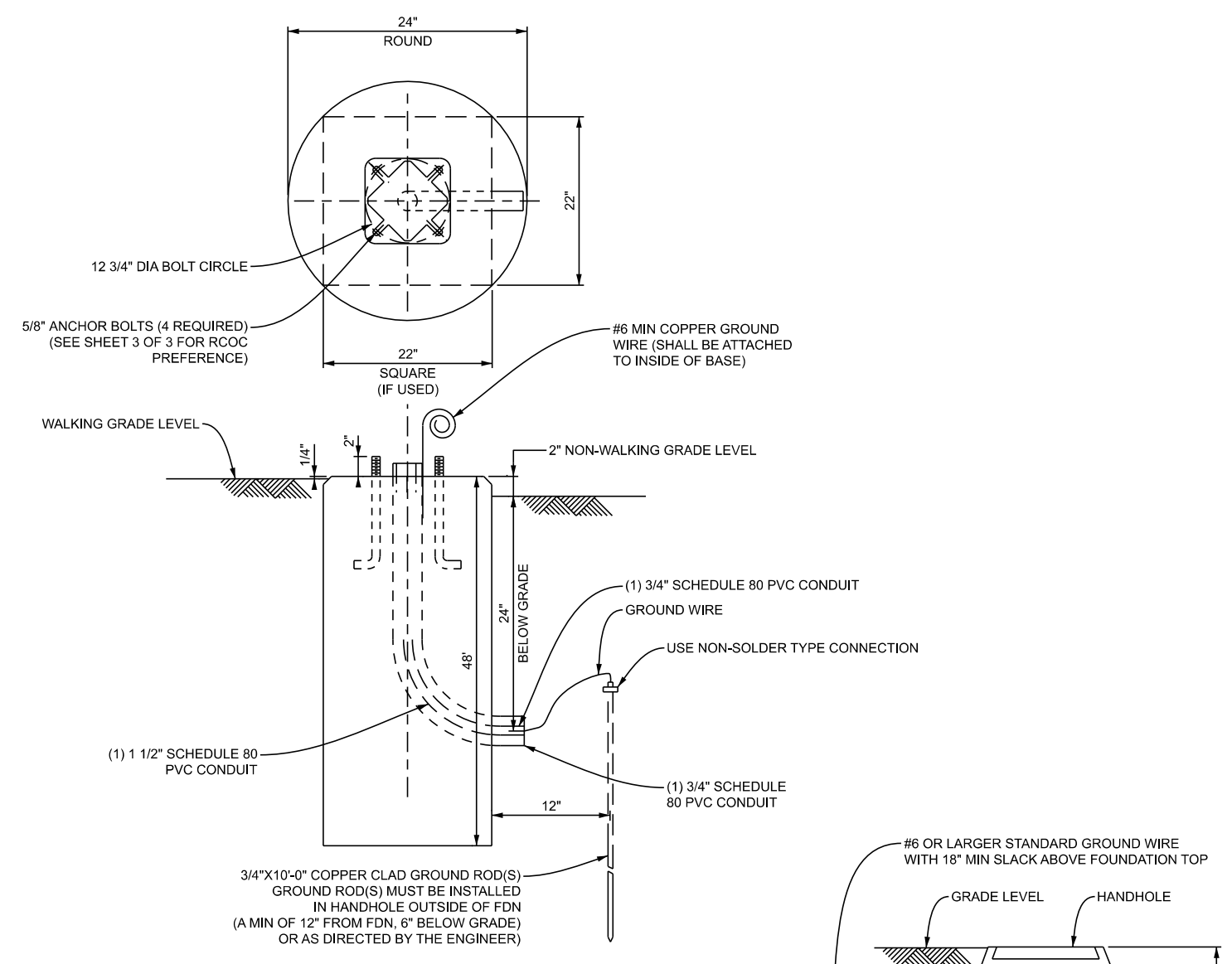

H DETAIL - PEDESTAL FOUNDATION
N.T.S. SEE NOTES 1, 2 & 3 ON SHEET 3 OF 3

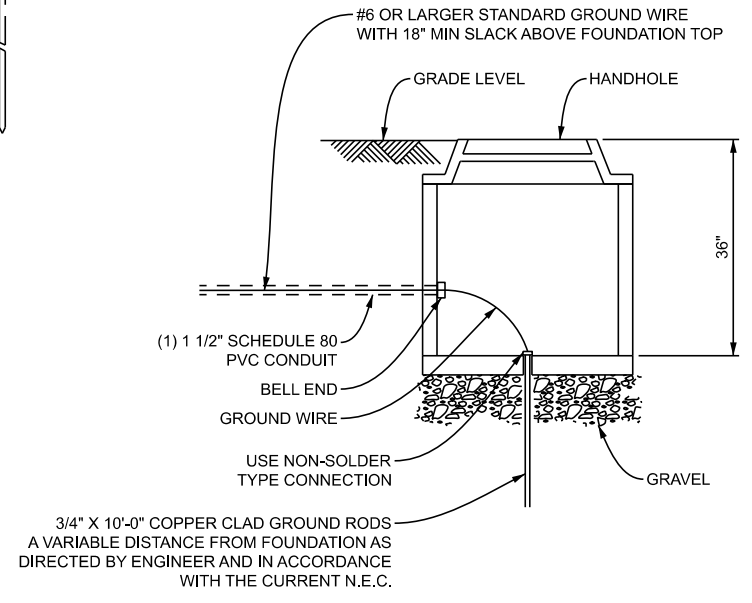

I DETAIL - HANDHOLE
N.T.S.

APPROVED BY: _____ DIRECTOR, BUREAU OF FIELD SERVICES	 Michigan Department of Transportation	STANDARD PLAN FOR PEDESTAL FOUNDATION		
APPROVED BY: _____ DIRECTOR, BUREAU OF DEVELOPMENT		(SPECIAL DETAIL) FHWA APPROVAL	10/29/2024 PLAN DATE	SIG-070-A

 Michigan Department of Transportation	STANDARD PLAN FOR PEDESTAL FOUNDATION		
	(SPECIAL DETAIL) FHWA APPROVAL	10/29/2024 PLAN DATE	SIG-070-A

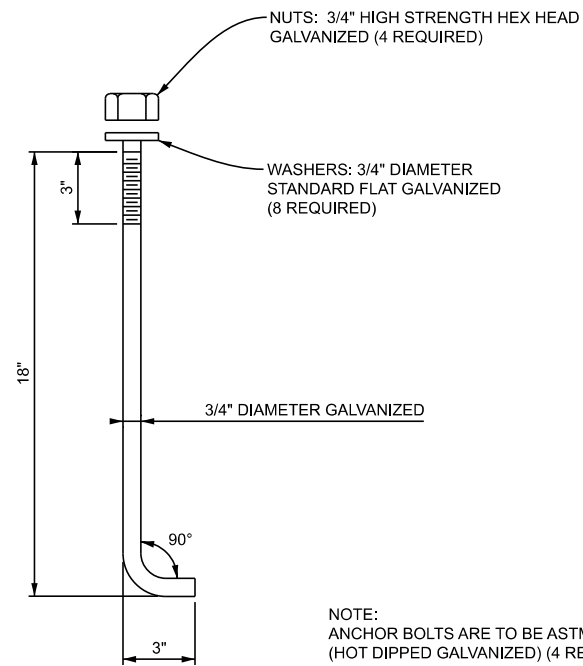

NOTE:
ANCHOR BOLTS ARE TO BE ASTM-F1554 GRADE 36 (HOT DIPPED GALVANIZED) (4 REQUIRED)

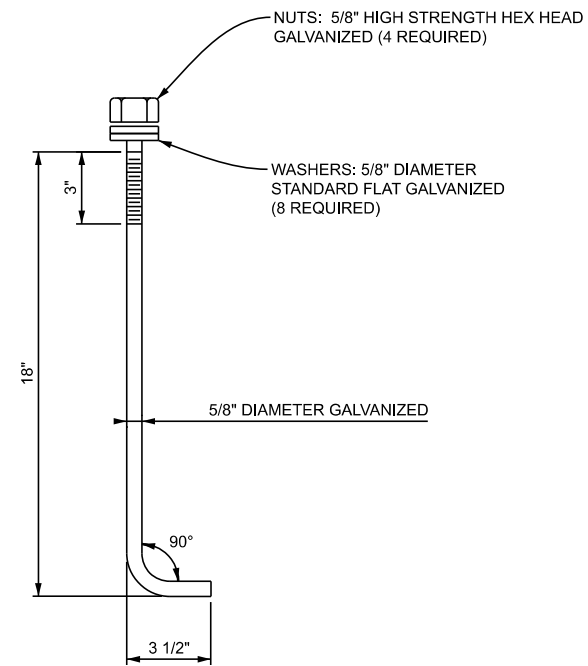

FOR USE ON OAKLAND COUNTY ROADS ONLY

FOR USE ON MDOT TRUNKLINE

J DETAIL - ANCHOR BOLT DETAIL
N.T.S.

- NOTES:
- 1) ALTERNATE FOUNDATION MAY BE CONSTRUCTED 22"X22" SQUARE - 48" DEEP.
 - 2) GROUNDING SYSTEM SHALL MEASURE 10 OHM OR LESS TO GROUND.
 - 3) CONSTRUCTION JOINTS NOT PERMITTED IN FOUNDATION.
 - 4) PEDESTAL BASE MUST MEET THE REQUIREMENTS OF NATIONAL COOPERATIVE HIGHWAY RESEARCH PROGRAM REPORT 350 (NCHRP 350) OR MANUAL FOR ASSESSING SAFETY HARDWARE (MASH) AND HAVE FEDERAL HIGHWAY ADMINISTRATION (FHWA) ACCEPTANCE. PEDESTAL BASE MUST ALSO BE CERTIFIED TO HAVE A 4-INCH MAXIMUM STUB HEIGHT AFTER THE SUPPORT HAS BROKEN AWAY FROM ITS BASE, AS SPECIFIED IN THE AASHTO STANDARD SPECIFICATIONS FOR STRUCTURAL SUPPORTS FOR HIGHWAY SIGNS, LUMINARIES, AND TRAFFIC SIGNALS AND THE AASHTO ROADSIDE DESIGN GUIDE.
 - 5) USE THE OCTAGONAL BASE AS A PREFERENCE BY THE ROAD COMMISSION FOR OAKLAND COUNTY (RCOC), FOR USE ON OAKLAND COUNTY ROADS ONLY.

APPROVED BY: _____
DIRECTOR, BUREAU OF FIELD SERVICES



APPROVED BY: _____
DIRECTOR, BUREAU OF DEVELOPMENT

DEPARTMENT DIRECTOR
BRADLEY C. WIEFERICH, PE

STANDARD PLAN FOR
PEDESTAL FOUNDATION

(SPECIAL DETAIL)
FHWA APPROVAL

10/29/24
PLAN DATE

SIG-070-A

SHEET
3 OF 3

SECT