

ACTION PLAN FOR CANTILEVER SIGN PROBLEM

Report To Management

Michigan Department of Transportation

April 1990

TE
228
C84
1990

ACTION PLAN
FOR CANTILEVER SIGN PROBLEM

Report To Management

Materials and Technology Division
James D. Culp

Maintenance Division
Maurice Witteveen

Design Division
Ho Lum Wong

April 1990

Michigan Department of Transportation
Lansing, Michigan

FOREWORD

Following two recent cantilever sign base failures, James P. Pitz, P.E., Director of the Michigan Department of Transportation, took immediate action to protect public safety.

The following action steps were taken by the Department:

First, cantilever signs were inspected as quickly as possible to identify any other signs that might be in danger of falling. Signs were taken down at once if they showed even minor deficiencies in the anchor rods that held them in place.

Second, a complete review was done of all past department activities involving cantilever signs including design, construction, inspection and maintenance. A thorough metallurgical analysis of the sign anchor rods that failed was begun by MDOT engineering research and by an outside engineer recognized as a national leader in metallurgical research.

Third, work was started on an action plan for the future to ensure a high level of confidence in the safety of these sign structures. The plan was to consider recommendations for new sign base design and construction techniques, as well as inspection programs and regular maintenance techniques. Both short term and long-term improvements were to be recommended. This action plan is the first step of that process.

The Michigan Department of Transportation will also participate in a program to determine the national extent of the problem. The department will provide leadership to change the national design code to consider fatigue analysis and wind-induced vibrations as part of the structural design of large cantilever sign supports.

A review of department actions since 1978 concerning cantilever sign supports is included in this report. MDOT actions and engineering facts are included in this document for public review.

INDEX

	<u>Page</u>
Executive Summary	4
1990 Action Plan	6
1. Initiate New, Ongoing Maintenance Inspections	
2. Replacement Schedule for Cantilever Signs	
3. Recommended Design and Construction Changes	
4. Recommendations for National Review	
Background on Cantilever Sign Problems	10
Research Reports on Sign Structures	15
1990 Cantilever Sign Accidents	23
1990 Complete Inspection Program of Cantilever Signs	25
Appendix	

Executive Summary

This report is the third step of the Michigan Department of Transportation's action program to prevent cantilever sign failures in the future and to ensure public safety.

The following action steps are being taken:

1. Regular inspection of all cantilever sign bases will be conducted at specific time intervals, using ultrasonic testing.
2. A replacement program be developed for any cantilever signs that are shown by our research investigation to require safety upgrading.
3. Design and construction practices will be revised, including a complete re-analysis of sign design, more accurate procedures specified for construction of bases and bolt tightening, and a method developed for locking the anchoring rod nuts in place.
4. A national review of the cantilever sign problems will be requested of both the Federal Highway Administration and the American Association of State Highway and Transportation Officials.

Dr. John Fisher, Director of the National Science Foundation Engineering Research Center on Advanced Technology for Large Structural Systems at Lehigh University was retained by the Department to conduct fractographic studies of broken anchor rods from the failed signs and a complete review of the sign failures.

A summary of the Department's work to inspect and redesign cantilever sign bases from 1978 to the present is presented. Some incidents of sign collapses in the 70's and early 80's triggered investigations into the problem by the Department. All indications at that time were that fatigue and fracture problems being observed on anchor rods of a few isolated sign structures were caused by the following:

- 1) Bent rods caused by improper construction,
- 2) Rods that were badly corroded,
- 3) Fatigue cracking caused by loose leveling and anchoring nuts.

Between 1983 and 1985 all cantilever sign structures on the state owned highway system were inspected by the Department. This inspection included the tightening of all leveling and anchoring nuts and ultrasonic testing of all anchor rods. The ultrasonic test method used was developed by the Department for this purpose and proved to be reliable in locating even very small cracks and other deficiencies in the anchor rods. At the completion of this inspection program in 1985 all deficient signs had been located

and removed from the highway system. Field inspections continued between 1985 to 1990 on a random sample of signs.

A summary of three research reports issued by the Materials and Technology Division in 1982, 1987, and 1989 is included. These reports document the problems and the recommended actions to be taken.

A review of the 1990 complete inspection program by the Department on all cantilever signs is presented. This inspection included physical testing of all anchor rods by sounding the rods and tightening the anchoring nuts. This was followed by ultrasonic testing on all anchor rods to detect any small deficiencies present. Seven cantilever signs with rod deficiencies were discovered. Although none were in imminent danger of falling, they were immediately removed to ensure motorist safety.

A comprehensive review of the design procedures used for the cantilever signs is currently being done by the Department with assistance from Dr. John Fisher.

1990 ACTION PLAN

1. Initiate New, Ongoing Sign Base Inspections

It is now apparent that a regular inspection program is necessary for the anchor rods in cantilever sign bases. A redundancy analysis by the Design Division has determined that the 8-rod bases can sustain full design loading, even if 2 of the 8 rods are broken. This allows us to establish a field inspection frequency based on finding the first rod to crack, usually rod number 1 which is opposite the cantilever arm, before additional rods begin to crack, which appears to happen only after rod number 1 is broken.

A yearly inspection cycle for small signs and a six-month cycle for large signs using both ultrasonic testing and nut tightening, will be sufficient to locate any fatigue cracking in the initial anchor rods before they could become critical. The following schedule is recommended for the next year to further gain experience in this problem:

- 1) Large cantilever sign structures, Type G and H (380 total signs).
Ultrasonic testing to be done every 6 months.
(October 1990 and April 1991).
- 2) Small cantilever structures, Type A, B, C, D, E and old Type I (827 total)
Ultrasonic testing to be done annually, starting in February 1991.
- 3) During the next scheduled sign inspection the structure number for each cantilever sign will be clearly stenciled on the pole with paint.

Dr. John Fisher of Lehigh University has been hired by the Department. He is a leading expert in the field of fatigue and fracture. (See Appendix).

He is currently conducting for MDOT fractographic analyses on fatigue-cracked anchor rods recently removed from a Type H cantilever sign. When these tests are completed (estimated by June 1990) he will be able to more accurately estimate the time involved in the fatigue cracking of an anchor rod.

Responsibility:

The periodic inspection of cantilever sign bases needs to be included as a regular responsibility of the Maintenance Division. For the next year, the inspections cited above will be done as a cooperative effort between the Maintenance and the Materials and Technology Divisions. This will allow the Maintenance Division to acquire the

necessary ultrasonic equipment and to develop the expertise to use it. Alternately they may establish consultant contracts to perform the ultrasonic testing.

2. Replacement Schedule for Cantilever Signs

Pending a full report from Dr. Fisher in June 1990, a program will be developed to replace any cantilever structures that may be evaluated as susceptible to fatigue by his new analysis. All sign structures now in service meet the standards of the current national design code.

Responsibility:

- Design Division to reevaluate design based on the full report by Dr. John Fisher.
- Traffic and Safety Division to develop a sign replacement program as required.

3. Recommended Design and Construction Changes

- A) A precise procedure for field installation of the nuts on the anchor rods will be specified. This will involve one of two methods presently being evaluated, either hydraulic torque wrench capable of applying an adequate tightening torque, or a method of pretensioning the anchor rods prior to tightening the anchoring nuts. A proper tension preloading of the anchor rod between the leveling and anchoring nuts reduces fatigue cracking by reducing the applied cyclic stress range.
- B) Improved construction techniques will be emphasized by the Construction Division in a Construction Circular letter and training sessions for field technicians and engineers. The revised standard plan for sign structures will place tighter maximum limits on the height of the leveling nut/base plate above the concrete base, emphasize the need to keep the anchor rods vertical and carefully explain the nut engagement and tightening requirements. Upon construction of a sign base and complete erection of the sign structure, it is recommended that the anchor rods all be inspected using ultrasonic equipment before final acceptance. This will ensure that no defects are built into the anchor rods by the construction process and placed into service without correction.
- C) Several commercially available "lock nut" devices are being evaluated by the Materials and Technology Division. If these prove to be effective,

they will be specified for use. A locking nut would eliminate the present tendency for nuts to loosen, which then leads to a fatigue cracking problem.

- D) Following a final report by Dr. John Fisher, the Design Division will re-analyze all existing sign structure designs and make any changes necessary. All existing sign structures meet requirements of the current national design code.

Responsibility:

- Materials and Technology Division to develop a recommended nut tightening procedure and to recommend a lock nut device.
- Construction Division to prepare field instructions on a Construction Circular letter and to provide field training.
- Design Division to re-analyze existing sign structures and make appropriate revisions to the standard plans and specifications.

4. Recommendations for National Review

Background: In late February, 1990 the Department began a preliminary nationwide survey to attempt to determine the extent of cantilever sign structure failures in other states and whether they have sign inspection programs. A Department inquiry was processed through the American Association of State Highway and Transportation Officials (AASHTO) Electronic Information System (EIS), an electronic mail and publishing system used by 42 AASHTO member departments, the Federal Highway Administration (FHWA), the Transportation Research Board (TRB), and the Strategic Highway Research Program (SHRP). States were asked if they had experienced similar failures in cantilever sign anchor rods and, additionally, if they had determined a cause for the failure and found a solution. The inquiry also asked if the state had implemented a regularly scheduled inspection program for sign supports, and if so, what did the inspection include? In addition to using the EIS, several direct phone calls were placed to various state highway and transportation departments.

A total of 20 initial responses has been received. All except two states reported they knew of no similar experience with anchor rod failures. One state reported a confirmed similar fatigue failure in anchor rods caused by loose nuts which allowed the structure to rock on the base. There were 14 states without any routine inspection program for sign structures. One state, however, was in the

process of developing such a program. Five states responded affirmatively that they conduct some form of inspection ranging in frequency from yearly to once every five years. The primary focus in these programs is a visual inspection. Physical testing and ultrasonic examination of the anchor rods are not part of any state's routine inspection, nor is any such routine inspection recommended by FHWA or suggested by the national design code. Michigan's ultrasonic testing program is unique for sign anchor rods.

The FHWA also conducted a survey and no failures of anchor rods were reported to them. At this time regional offices of FHWA are unaware of similar problems around the country or of any inspection program involving ultrasonic testing of anchor rods in sign structures.

Recommendation 1:

It is recommended that the Federal Highway Administration (FHWA) report the Michigan experience and use its influence to initiate a nationally sponsored research effort for cantilever sign bases. It is apparent that the problem is not necessarily unique to Michigan and similar anchor rod failures and accidents could occur in other states.

Responsibility: Federal Highway Administration - Michigan office.

Recommendation 2:

The fatigue design considerations now present in Michigan's design and the importance of proper construction, nut tightening and periodic ultrasonic inspection should be evaluated by the AASHTO Structures Committee and shared with other states.

The Department will recommend that the AASHTO Structures Committee review the "Standard Specifications for Structural Supports for Highway Signs, Luminaires and Traffic Signals," the national design code for cantilever signs and anchoring rods. It is apparent that the current code needs to be updated in addressing the areas of fatigue, the effects of wind-induced vibration, analyses for vortex shedding, requirements for anchor bolt tightening and nut locking procedures, and the need for periodic inspection for fatigue cracking to prevent structural collapse.

Responsibility:

Design Division to write a report and inquiry to the AASHTO Structures Committee.

Background on Cantilever Sign Problems

January 1978 to 1980

Action:

In January 1978 the Research Laboratory Section of the Testing and Research Division (now the Materials and Technology Division) initiated a Research Project 77F-153, "Static and Dynamic Properties of Anchor Bolts for Sign Supports." This study was to investigate the occurrence of fatigue cracking and fracture of the large diameter anchor rods that were used to position and hold the bases of cantilever sign structures (Fig. 1).

Metal fatigue occurs when repeated loads are applied and removed from a structural component, eventually causing small cracks to develop and then grow in size (similar to bending a wire back and forth until it breaks). Prior to this research investigation, there had been a few instances of the anchor rods fracturing in cantilever signs, allowing the sign structure to fall onto the roadway causing some vehicle damage. It was evident from viewing the fractured rods that some fatigue cracking was occurring prior to the fracture. The postulated causes for such fatigue cracking in this research study were:

- 1) improper construction practices which left the rods bent after being installed in the base,
- 2) a possible effect of the hot-dip galvanizing process lowering the fatigue life as reported by the American Hot Dip Galvanizers Association, based on some research done in England.

At that time the national design code used by highway departments throughout the country for sign structure design was the "Standard Specifications for Structural Supports for Highway Signs, Luminaires and Traffic Signals," 1975 edition, published by AASHTO.

It is important to note that this code reflects a general state-of-the-art in the highway sign industry. It did not include an analysis of wind-induced vibrations or provide an understanding of what their effects might be. This design code included only an overview of fatigue and vibration of sign structures that can be caused by wind loading and the shedding of "Karman vortices" from the surfaces of the sign and support. These Karman vortices are small, localized whirlwinds that form by the turbulence of the wind passing over the sign surfaces. When the whirlwinds or vortices leave the surface they cause a pressure differential which induces a vibration in the sign. Similar effects are the eddies or whirlpools that can be seen when flowing water passes a bridge pier or similar object.

In 1980 the Design Division completed a design check of the size of the anchor rods

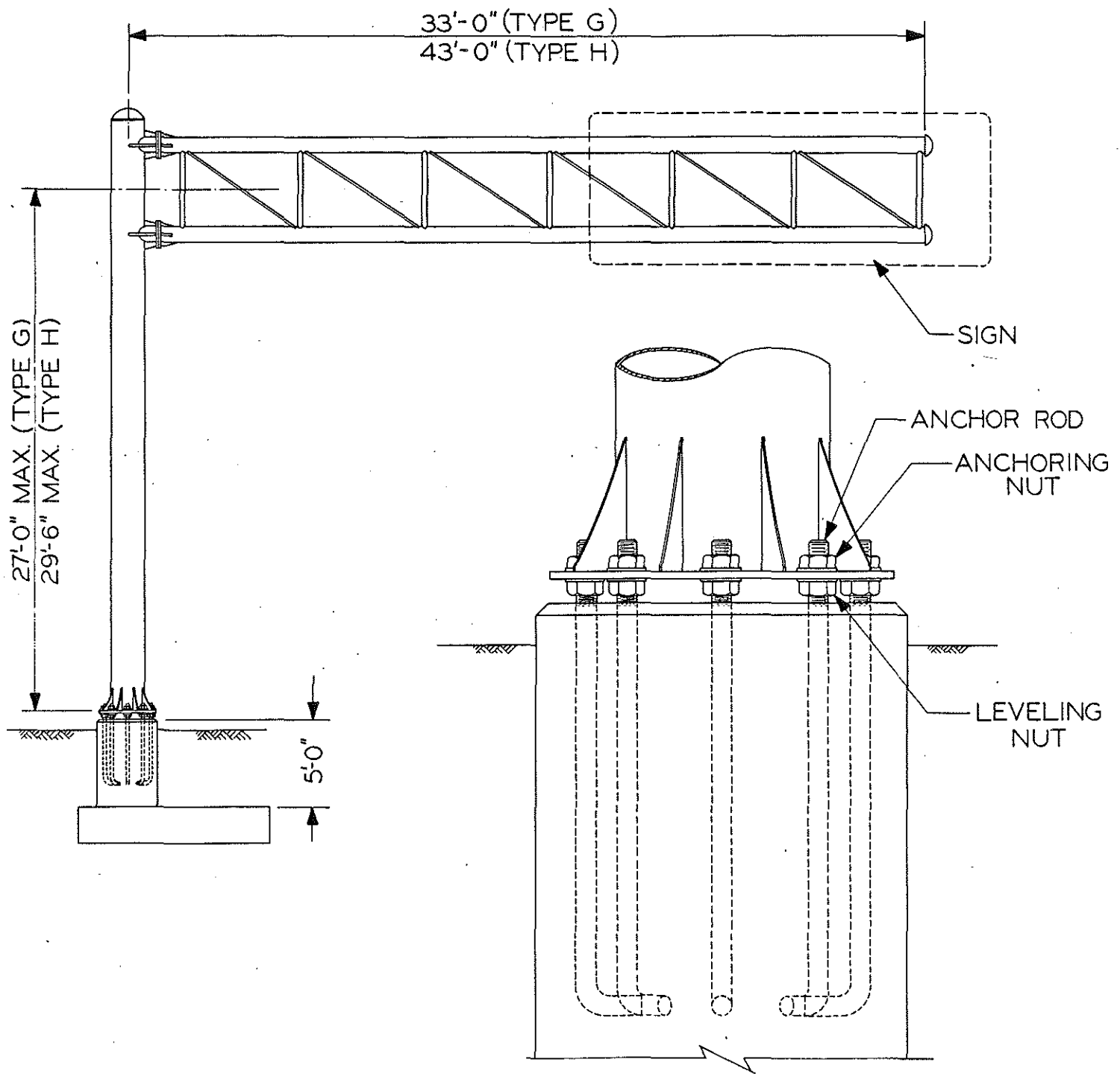

Figure 1. Cantiliver type G & H.

In 1980 the Design Division completed a design check of the size of the anchor rods using a new computer program that was developed from 1977 through 1979. All sizes of signs were analyzed and the Type G cantilever was the only one requiring a modification of anchor rod size according to the new computer analysis. A slight overstress in combined shear and bending was noted for the 1-1/2-inch diameter rods in the Type G sign structure.

Action:

The specified rod size was increased from 1-1/2 to 2-inch diameter. This change increased the bolt area by 77 percent, which effectively reduced the applied stress and fatigue stress range of the anchor rods in service. (At that time the AASHTO Design Code gave little guidance relative to fatigue analysis of anchor rods. The MDOT design change was based on a combined stress analysis, not a fatigue analysis.) The Type G cantilevers with 1-1/2-inch diameter anchor rods were left in service. This decision was made because a redundancy analysis shows the structure could still withstand the maximum design loading caused by a 104 mph wind, with two of the eight anchor rods completely broken. Hence, no safety problem was known to exist at that time. (These structures were evaluated again in 1990 by ultrasonic testing to ensure no defects exist in these anchor rods that could affect their safety.)

1980 to 1985

Several actions were taken to identify and remedy any problems that might exist in cantilever sign bases. The most significant of these actions were:

- 1) field inspections of existing cantilever sign bases to attempt to identify the extent of the anchor rod cracking problem
- 2) development of an ultrasonic testing procedure to locate partially cracked anchor rods in cantilever bases.

Initial field inspections showed the anchor rod cracking was limited to isolated instances where the following problems existed:

- 1) rods were bent by improper construction practices,
- 2) rods were badly corroded,
- 3) fatigue cracking of the rods was caused by the stresses induced by loose anchoring nuts.

It was noted in 1980 in Department correspondence that several instances of loose anchoring nuts had been located and tightened during field inspections. It was recognized at that time that loose nuts could induce additional fatigue stress range into the anchor rods, possibly explaining why fatigue cracking happened in the few cases discovered. At that time loose nuts were thought to be the major cause of such fatigue cracking.

Action:

1. Development of Ultrasonic Testing Method

The ultrasonic test method was developed by the Testing and Research Division to reliably locate fatigue cracks as small as 1/4 inch. The ultrasonic test method involves the transmission of sound waves into the end of an anchor rod using a small transducer or sender. If any cracks or defects are present they reflect sound waves back to the transducer which then displays their location and size on a portable test machine with a display screen. Laboratory testing of this method verified that it could detect and accurately locate any defects in the anchor rods that were large enough to be of concern.

2. Field Inspection Program

With the development of the ultrasonic test method, the Department began in early 1982 to develop a program to inspect all the cantilever signs on the state owned highway system. This inspection program included ultrasonic testing of all anchor rods, tightening of all anchoring and leveling nuts and a general inspection for other problems, such as bent or badly corroded anchor rods. This inspection was started in December of 1982 and completed in the spring of 1985. The inspection involved a total of four two-person inspection teams, working mostly in the winter months.

The following presents a summary by year of the number of cantilever signs found with deficiencies in the anchor rods during this three-year inspection program.

1982-'83

11 bases with rod deficiencies

1983-'84

18 bases with rod deficiencies

1984-'85

5 bases with rod deficiencies

Action following Inspections:

- A. The types of anchor rod deficiencies found were as follows:
- 1) cracked rods
 - 2) bent rods
 - 3) broken rods
 - 4) badly corroded rods
 - 5) one rod with stripped threads
 - 6) short or missing rods

The deficiencies listed in 1 through 4 above were all identified by the ultrasonic testing. The Maintenance Division worked closely with the inspection crews during the 1982 to 1985 period and whenever a deficient base was found, the Lansing Overhead Sign crew would immediately remove the sign structure.

- B. During this three-year inspection program, numerous loose anchoring and leveling nuts were discovered. These nuts were all tightened by the inspection crews. Loose nuts were thought to be the major factor in the occurrence of fatigue cracking. There is still evidence to support this hypothesis.

3. Improvements in Construction Practice

The use of templates for positioning anchor rods and holding them plumb during the pouring of concrete into the base was required starting in 1980. This decreased the likelihood of bolts being out-of-plumb and then being bent to plumb by contractors after the base was poured. Out-of-plumb anchor bolts create bending stresses during nut tightening and subsequent loading. Bending of anchor rods by the contractor after the base concrete is set can initiate a crack at the root of the thread which then will grow by fatigue loading.

1986 to 1990

Action:

Additional field inspections were done using ultrasonic testing during 1986 to 1990. These were conducted by engineering technicians from the Materials and Technology Division working in response to requests from the Overhead Sign Shop of the Lansing Maintenance Division. The inspections were conducted in 1986, 1987, 1989 and early 1990. No inspections were done in 1988. A total of 279 cantilever structures were inspected over this time period. The following is a summary of the deficiencies found on old sign bases.

1986 Inspections

2 bases with deficient rods (90 signs tested)

1987 Inspections

2 bases with deficient rods (88 signs tested)

1989 Inspections

2 bases with deficient rods (27 signs tested)

1990 Inspections

3 bases with deficient rods (74 signs tested)

The types of anchor rod deficiencies found were cracked rods, broken rods and rods with stripped threads. All sign structures were immediately removed when ultrasonic testing revealed any deficiencies present.

Research Reports on Sign Structures

From June 1982 through September 1989, three research reports were issued by the Testing and Research Division. Following is a summary of the conclusions of the reports and the actions taken by the Department in response to the recommendations made. The reports are available at the Materials and Technology Laboratory by calling (517) 322-5663.

1. Research Report R-1197

"Static and Dynamic Properties of Anchor Bolts for Sign Supports," June 1982

The report investigated anchor bolt failures that occurred in cantilever sign structures. Objectives of the investigation were as follows: 1) to determine the effect of galvanizing on the fatigue life of typical anchor bolts; 2) to determine the effect of nut engagement on the static strength of typical anchor bolt assemblies; and, 3) to determine the effect of closeness of fit of the nut and bolt on the static strength of selected bolt-nut combinations.

Conclusion No. 1

"Galvanizing reduced the fatigue life of anchor bolts."

Explanation:

This factor was not generally recognized as a problem in 1982 and was the reason for the recommendations listed later in the report.

Conclusion No. 2

"Anchor bolts obtained by special purchase and from the MDOT warehouse failed to meet the specification requirements for yield and ultimate strength."

Explanation:

The specially purchased 2-inch diameter threaded rods were intended and used only for this particular research project. They were merely threaded rods made up for this experimental work by a machine shop that offered to do so at the lowest bid.

Generally, warehouse purchases are for MDOT sign shop use in repairing or replacing signs, or for new locations. Only 1-1/2-inch bolts are stocked at the warehouse. Our research results were referred to both the warehouse and the sign shop, so that the 1-1/2-inch bolts would not be used.

Conclusion No. 3

"Bolts obtained from the warehouse had unusually low fatigue lives."

Explanation:

When all of the bolts in this experiment were evaluated by cyclic loading to simulate the design load (which includes the dead load of the structure plus repeated applications of 104-mph wind), these particular 1-1/2-inch bolts could withstand considerably fewer applications of the load before failure. Even these bolts, however, endured an average of more than 156,000 applications of the maximum design loading, which exceeds the number of times the maximum wind loading of 104 mph could occur during the life of the sign structure.

Conclusion No. 4

"The amount of nut engagement is an important factor in determining the strength of an anchorage. Less than one diameter of engagement reduces strength."

Explanation:

This confirms the facts demonstrated by many other studies. It should be clarified that this factor is related to the static load tests accomplished rather than the fatigue tests.

Conclusion No. 5

"Ultrasonic non-destructive evaluation was found to be capable of finding fatigue cracks in anchor bolts, even at relatively small sizes."

Explanation:

It was necessary to experiment with the ultrasonic equipment, (normally used for testing welded steel bridge beams 2 or 3 inches thick) to determine whether fatigue cracks in the threaded portions of these long anchor bolts would be readily detectable. Laboratory experiments with simulated cracks in such bolts determined that MDOT equipment would be suitable for such purposes.

Recommendation No. 1

"It is recommended that a directive or specification be written to the effect that on all bolted connections the nut be threaded onto the stud for at least the full depth of the nut plus 1/4-in. If the projection isn't sufficient to accomplish this, and there are compelling reasons for not removing and replacing the foundation, effective engagement should be obtained by making larger holes in the plate and using a special oversize nut with a reduced section and shoulder. This type of device was developed many years ago for such applications."

Action:

The next issue (1984) of the MDOT book of Standard Specifications for Construction contained a revised section as follows: 6.26.09-e "The anchor bolts shall be accurately positioned in accordance with the plans and firmly held in position during concrete placement. The concrete shall be placed and the seat struck off at the elevation shown on the plans and finished to a horizontal smooth surface. The cantilever or truss sign supports shall not be erected until the anchor bolts have been inspected and approved by the Engineer for accuracy in the positioning of the bolts on the bolt circle, plumbness of the bolts, and the height of the bolts above the seat.

Improper positioning, lack of plumbness, or improper height of anchor bolts shall be corrected as directed by the Engineer."

Recommendation No. 2

"Design Stresses for Anchor Bolts should be reduced by 25 percent, especially for cantilever type sign supports."

Action:

A design review was done in 1982 resulting in significant changes in the anchor bolt sizes used for the largest (type H) cantilever signs. The anchor bolt size was increased from 2 to 2-1/2 inches in diameter, resulting in a 60 percent increase in bolt stress area. The bolt circle also was increased from a 30 to a 31-inch diameter, which would reduce stresses still further. The existing Type H cantilevers with the 2-inch diameter anchor rods were left in service. This was done because a redundancy analysis showed the structure could still withstand the maximum design loading, caused by a 104 mph wind, with two of the eight anchor rods completely broken. An ultrasonic inspection program to be conducted by the Department would eliminate any potential safety problems.

Anchor bolt diameter for the type G cantilevers had been increased in 1977 from 1-1/2 to 2 inches. A recheck of the design in 1982 indicated that the recommended stress reduction had been accomplished by the design change which increased the stress area of the bolts by 77 percent.

No failures have occurred in the larger size anchor rods.

A design review shows that no changes were necessary in the other sizes of cantilever sign structures.

Recommendation No. 3

"Additional acceptance testing should be conducted on anchor bolts to improve the probabilities that specified strengths are obtained."

Action:

Maintenance orders for anchor bolts, either directly or through the warehouse, must have samples submitted to the Laboratory for testing prior to use. In 1984 one batch of 100 bolts was rejected, and the order was cancelled. All other such bolts ordered since that time have been tested and met specification requirements. After approval, bolts are assembled into cages for placement in the sign bases. Once assembled, a M&T inspector checks the bolts for flaws using an ultrasonic testing unit. When all bolts have been checked and approved, the bolts are cast into a new concrete base.

A review of available test reports from the M&T Division for the years 1984-89 shows significant increases in the number of anchor bolts tested for all purposes, including those used for cantilever sign supports. This verifies compliance with the recommendation.

Recommendation No. 4

"Experimental measurements should be done to determine the actual dynamic stresses in anchor bolts for large cantilevers in service."

Action:

This task has not been completed, but now is in progress. Field testing will involve the placement of small strain gages on the shank of the anchor rods to directly measure the stresses induced by wind loading. These data will give a direct measure of the fatigue or cyclic stress ranges being experienced by the anchor rods.

Recommendation No. 5

"An inspection program using ultrasonic inspection equipment should be carried out to determine the condition of existing anchor bolts in the field. Any loose nuts should be tightened."

Action:

This was done by M&T forces during the winters of 1983 through 1985 as previously explained in this report.

Recommendation No. 6

"Further work should be done to identify corrosion resistant anchor bolts that are less susceptible to fatigue."

Action: This was done, See the next Research Report R-1283.

2. Research Report R 1283 -

"Static and Dynamic Properties of Anchor Bolts for Sign Supports (Final Report)," June 1987.

This report covered the additional laboratory evaluations that were suggested in recommendation No. 6 of the previous report. The report reconfirmed some of the previous conclusions. Bolts used were galvanized and ungalvanized from the same bar stock, plus stainless-clad and solid stainless steel bolts. All anchor bolts evaluated in this report exceeded the static yield and ultimate strength requirements of MDOT specifications by significant amounts. However, this experiment demonstrated also that increased static strength does not automatically cause similar increases in fatigue life.

Full-sized stainless steel bolts should be considered for especially severe environments if galvanized bolts show poor durability.

Explanation:

At the time that this work was in progress, the British steel companies that manufactured the stainless clad bars were attempting to get production started in the USA. Later this effort failed, so that type of bolt became unavailable. Solid stainless bars were available, but proportionately higher in cost, since the stainless material in the center of the bar is far more expensive than the carbon steel in the clad bars. It appeared at the time of the report that the redesigned larger galvanized bolts had solved the problem for new installations, and that the stainless bolts would not be necessary.

(Note: Following is MDOT re-evaluation in 1990:

It is not recommended that we change to stainless steel at this time. The stainless steel alloy tested is only currently available from England and has a tensile strength of around 170,000 psi. The only domestically produced stainless alloy that is similar has a tensile strength of around 110,000 psi. This in effect would lessen the increase in fatigue resistance offered by the foreign stainless steel. In addition, careful review of the steel selection literature reveals that these stainless steels may be prone to develop pits in the salt environment of the highway system. These pits would be very hard to locate by inspection and would create stress raisers which could then initiate a whole new set of fatigue cracking problems.)

3. Research Report 1302 -
"Inspection of Sign Support Structures," September 1989.

This report covers evaluation of sign support structures, the poles and trusses themselves, rather than the anchor bolts that secure them to the foundation (82 cantilever and 36 overhead truss supports were inspected).

Conclusion No. 1

"In spite of the problems discussed above that were encountered on various sign structures, it can be concluded that these structures are safe and providing the intended service."

Action:

Specific problem areas were noted and referred to Maintenance staff for attention.

Conclusion No. 2

"The problems that were frequently encountered on overhead sign trusses include cracking of welds, splitting of tubular members, and the splitting of aluminum nuts and bolts due to corrosive. Certain fabrication and erection procedures seem to be the cause of some of these problems. The Maintenance Division is already aware of these problems and every effort is being made to take corrective action. The corrections action involves rewelding the cracked welds, replacing the split members, and replacing aluminum nuts and bolts by stainless steel ones, or aluminum series 6000 alloy nuts and bolts where available."

Action:

Localized problems with cracking of secondary members, corrosion of old 2000-series aluminum bolts and nuts, and minor cracking of welds were noted and referred to the Maintenance Division for action. Maintenance forces report that all of the noted problems have been addressed.

Conclusion No. 3

"In the Detroit metropolitan area splitting of aluminum nuts and bolts at the base connection on aluminum sign trusses could be seen at a much higher rate. The corrosive environment encountered in the Detroit area justifies early removal and replacement of these defective parts."

Action:

Splitting of aluminum nuts and bolts was noted in some base connections in the Detroit area. Previously, cooperative action between Research and Maintenance forces had identified deficiencies in the older 2000-series aluminum bolts and

switched over to the stainless steel and series 6000 aluminum bolts in the sizes available to use in the assembly of the sign support structures. This inspection program found some of the remaining large 2000-series aluminum bolts in the base connections of the large sign trusses that still needed to be replaced. Maintenance forces indicate that these areas have been addressed.

Conclusion No. 4

"The performance of galvanized cantilever sign structures has been excellent, except for a few hairline cracks that were observed in the post around the gusset plates where the arm is connected to the post. If these cracks are fatigue-induced they may indicate potential problems. Further determination of the cause of these cracks is desirable; otherwise, there do not seem to be any problems with this type of structure. These structures are still capable of providing trouble free service for years to come. Recent inspection of the old galvanized supports on the Lodge Freeway reconstruction confirmed excellent performance over many years."

Action:

This conclusion deals with small vertical cracks adjacent to welds in the upper part of the large vertical tubes of the supports on some signs. The causes for these cracks are under further investigation, and also have been referred to Dr. John Fisher for his recommendation.

Conclusion No. 5

"The coating on a few of the painted cantilever structures that were inspected is in poor condition. The majority of these structures need immediate painting or replacement with galvanized steel structures. The Maintenance Division has been replacing painted cantilever structures with galvanized steel structures for quite some time."

Action:

This conclusion deals with some old cantilever structures that were erected prior to the use of galvanizing on such supports. These are in the process of being replaced, as funding is available.

Conclusion No. 6

"The majority of the flange-connecting bolts on overhead trusses were stainless steel AISI 300 series. These bolts are holding up excellently in the field and there seems to be no problems associated with them. Since the failure of these bolts in service has not been seen or reported, determination of their properties by means of destructive testing does not seem necessary at the present time. The use of these bolts should be continued."

Action:

This conclusion deals with the good performance of stainless steel bolts in the flange connections, and recommends their continued use. No additional action required.

Conclusion No. 7

"The majority of connecting bolts at arm-to-post connections are galvanized steel except for a few old structures that use ordinary steel bolts. These bolts are showing signs of corrosion but are in fair condition. Even though these bolts were not tested for any mechanical properties in the laboratory, at the present time there does not seem to be significant sectional loss in these bolts due to corrosion. Replacement of these bolts is recommended, however, since they will continue to corrode."

Action:

These were referred to Maintenance for review and reportedly have been addressed.

Conclusion No. 8

"Even though high-mast luminaire supports were not included in this investigation, based on a preliminary inspection their field performance appears to be satisfactory at the present time. The existence of improper drainage at the base of the post presents a potential problem on some installations. Reinspection of another random sample of these supports after an additional five years of service is recommended."

Action:

This part refers not to sign supports, but to tower lights, and has found performance of these devices to be satisfactory at the present time. Reinspection of these structures was recommended within five years or by September 1994. Some additional inspections have been done recently, and more will be done within the recommended time period. No problems have been determined to date.

1990 Cantilever Sign Accidents

Early in 1990 two accidental collapses of cantilever sign structures occurred in close succession. These were the first reports of any failures of anchor rods since 1982. During 1982 through 1985, all cantilever sign structures on the state's highway system had been inspected with ultrasonic testing and all bases with deficient anchor rods had been removed.

Accident 1

Date: January 25, 1990

Location: District 8
Northbound I-75 approximately 1/4 mile south of the
Erie Temperance Exit (Exit 2).

Cantilever Type:
Type G structure
1-1/2-inch diameter anchor rods
8-anchor-rod base

Original Construction Contract:
C.S. ID Number - I 58151
Job Number - 09402A
Contractor - Macomb Contracting Company
Fraser, Michigan
(No longer in business)

Damage: Cantilever fell onto freeway and was hit by a pickup truck causing property damage. Personal injuries were minimal.

Accident 2

Date: February 16, 1990

Location: Metro District
Northbound M-39 at Michigan Avenue
Dearborn, Wayne County

Cantilever Type:
Type H Structure
2-inch diameter anchor rods
8-anchor-rod base

Original Construction Contract:
C.S. ID Number - ROS 82192
Job Number - 11230A
Contractor - Macomb Contracting Company
Fraser, Michigan
(No longer in business)

Damage: Cantilever fell onto roadway onto a passenger car, resulting in the death of a woman and personal injuries to the man driving. Two other vehicles were involved in the accident causing both property damage and personal injuries.

The causes of these two sign failures are under intensive investigation by the Department. Information and results of these investigations will be released pending the outcome of litigation now filed against the Department.

1990 Complete Inspection Program of Cantilever Signs

After the first accidental collapse of the Type G cantilever sign on I-75 (January 25, 1990), personnel from the Maintenance Division's Overhead Sign Shop and the Materials and Technology Division's Structural Services Unit began ultrasonic testing and general inspection of cantilever sign bases in the vicinity of the accident. Thirty-three cantilever bases were inspected and ultrasonically tested. No additional deficiencies were found prior to the occurrence of the second accidental collapse of the Type H cantilever sign on M-39 (February 16, 1990). Thus, the personnel involved had no reason to suspect that a general problem with the anchor rods had reoccurred.

Physical Testing Program

On Wednesday, February 21, 1990, a statewide emergency program began, consisting of a general inspection and physical testing of the Department's complete inventory of cantilever sign structures (approximately 1200 total). This work was carried out by personnel in each District from the Maintenance, Construction and Materials and Technology Divisions. The physical testing involved sounding all anchor rods and nuts by striking with a hammer and torque testing by tightening the top anchoring nut with a wrench. The sounding was used to quickly identify any broken or badly cracked anchor rods which give a different sound than a good rod. Previous experience had shown this to be an effective way to quickly identify any critical safety problem.

The physical testing program was completed in three days on 380 Type G and H cantilever structures, all Districts reporting completion by Saturday, February 26, 1990. This resulted in the removal of one Type H cantilever structure with 2-inch diameter anchor rods on U.S. 127 Northbound south of I-96, Ingham County, District 8. Anchor rod number 1 was found to be broken off at the bottom of the top anchoring nut.

The physical testing program on the smaller size cantilevers, Types A, B, C, D, E and old Type I, was completed March 7, 1988 on 827 structures. This resulted in the removal of one Type D cantilever structure with 1-1/2-inch anchor rods on I-75 at Front Street, Monroe County, District 8. This sign base was found to have 1 rod out of 8 missing as originally constructed.

Ultrasonic Testing Program

During the week of February 19-24 the Department also initiated an ultrasonic testing program to immediately follow up the District's physical testing of all cantilever structures. This involved a total of six two-man crews. Four of the crews were made up of engineering technicians from the Materials and Technology Division and two of the crews were made up of an ultrasonic technician hired from a testing consultant and

a district maintenance worker. These crews first performed ultrasonic testing on the 378 Type G and H cantilever signs with all testing being completed on March 8, 1990. They then proceeded to ultrasonically test all 827 Type A, B, C, D, E and old Type I cantilever signs with all testing being completed the week ending April 13, 1990.

Following is a listing of seven cantilever structures that were found to have deficient anchor rods by either the physical testing or the ultrasonic testing:

Metro District:

Structure Report #819 I-75/Allen Rd. Wayne Co., Southgate Type G, 1-1/2 " rods (defects in rods #1 and #8 as originally constructed-improper welding on nuts) IS 82191-09980A*	Structure Report #237 I-96/Farmington Rd. Wayne Co., Exit 174 Type G, 1-1/2" rods (deficiency rod #8 found by ultra- sonic) N 82122-10798*	Structure Report #687 US-12 W. Bd./300' W. of Birch Street Type H, 2-1/2" rods (deficiency rod #6 found by ultrasonic) FU 82062-20128A*
Structure Report #17 S.B. M-53 (Between 13 Mile & 14 Mile Rd.) Macomb Co. Type I, 1-1/2" rods (4 total rods) (deficiency rod #3 found by ultrasonic, built in the 1960's)	Structure Report #168 E.B. M-153 at S.B. M-39 Wayne Co. Type D, 1-1/2" rods (rod #8 defective as constructed)	

District 8:

Structure Report #158 U.S. 127 N. Bd/S. of I-96 Ingham Co. Type H, 2" rods (rod #1 completely broken) FR 33031-15928A*	Structure Report #576 I-75/Front St. Monroe Co: Type D, 1-1/2" rods (1 rod missing as originally built) IS 58151-08508A*
--	---

*Control Section I.D. and Job Numbers for original contracts.
These seven structures represent the only deficient cantilever bases found statewide out of 1205 signs inspected.

Design Review

Concurrent to the recent inspection program a complete review of all cantilever designs was initiated by the Design Division. This review started with a reevaluation of all existing signs in accordance with the current provisions of the AASHTO "Standard Specifications for Structural Supports for Highway Signs, Luminaires, and Traffic Signals," which is the national code for such structures. All cantilever signs on the Department's highway system meet or exceed the requirements of this national design code.

Recognizing that fatigue problems are occurring that are not addressed by the national AASHTO design code, the Department's Design Division is investigating methods for analyzing the effects of wind-induced vibrations and vortex shedding phenomena. Dr. John Fisher of Lehigh University is also working on these types of advanced analysis techniques. This information, when completed, will be recommended to the AASHTO Structures Committee for inclusion in future editions of the national design codes.

APPENDIX 1

RESUME'

Dr. John W. Fisher
Stuart Professor of Civil Engineering
Director, ATLSS Engineering Research Center
Lehigh University
Bethlehem, Pennsylvania 18015

Dr. John W. Fisher has been Professor of Civil Engineering at Lehigh University since 1969. He was named to the Joseph T. Stuart Chair in Civil Engineering at Lehigh in July 1988.

Dr. Fisher has been Director of the National Science Foundation's Engineering Research Center on Advanced Technology for Large Structural Systems (ATLSS) since its establishment in May 1986. The Center acts as the national focal point for scientific research and as an agent for innovative change needed to advance technological developments that will dominate large structural systems in the construction industry in the 21st century.

A structural engineer, Dr. Fisher is a specialist in structural connections, the fatigue and fracture resistance of riveted, bolted and welded structures and the behavior and design of composite steel-concrete members.

He has authored Fatigue and Fracture in Steel Bridges; Case Studies, published in 1984, and the 1st and 2nd Edition of Guide to Design Criteria for Bolted and Riveted Joints published in 1974 and 1987, respectively, and about 150 contributions to various scientific and engineering journals.

A Fellow of ASCE, Dr. Fisher received the prestigious Construction-Man-of-the-Year Award from Engineering News-Record magazine in 1987, the first member of the academic community to receive this award. In 1986 he was elected a member of the National Academy of Engineering.

In 1956 Dr. Fisher received the Bachelor of Science degree in Civil Engineering from Washington University, which also presented him with its 1987 Engineering Alumni Achievement Award. He received his Master of Science and Doctor of Philosophy degrees from Lehigh University in 1958 and 1964, respectively. In 1988, he received an honorary doctorate degree from the Swiss Federal Institute in Lausanne, Switzerland.

