

VIBRATION and DEFLECTION of ROLLED BEAM and PLATE GIRDER TYPE BRIDGES

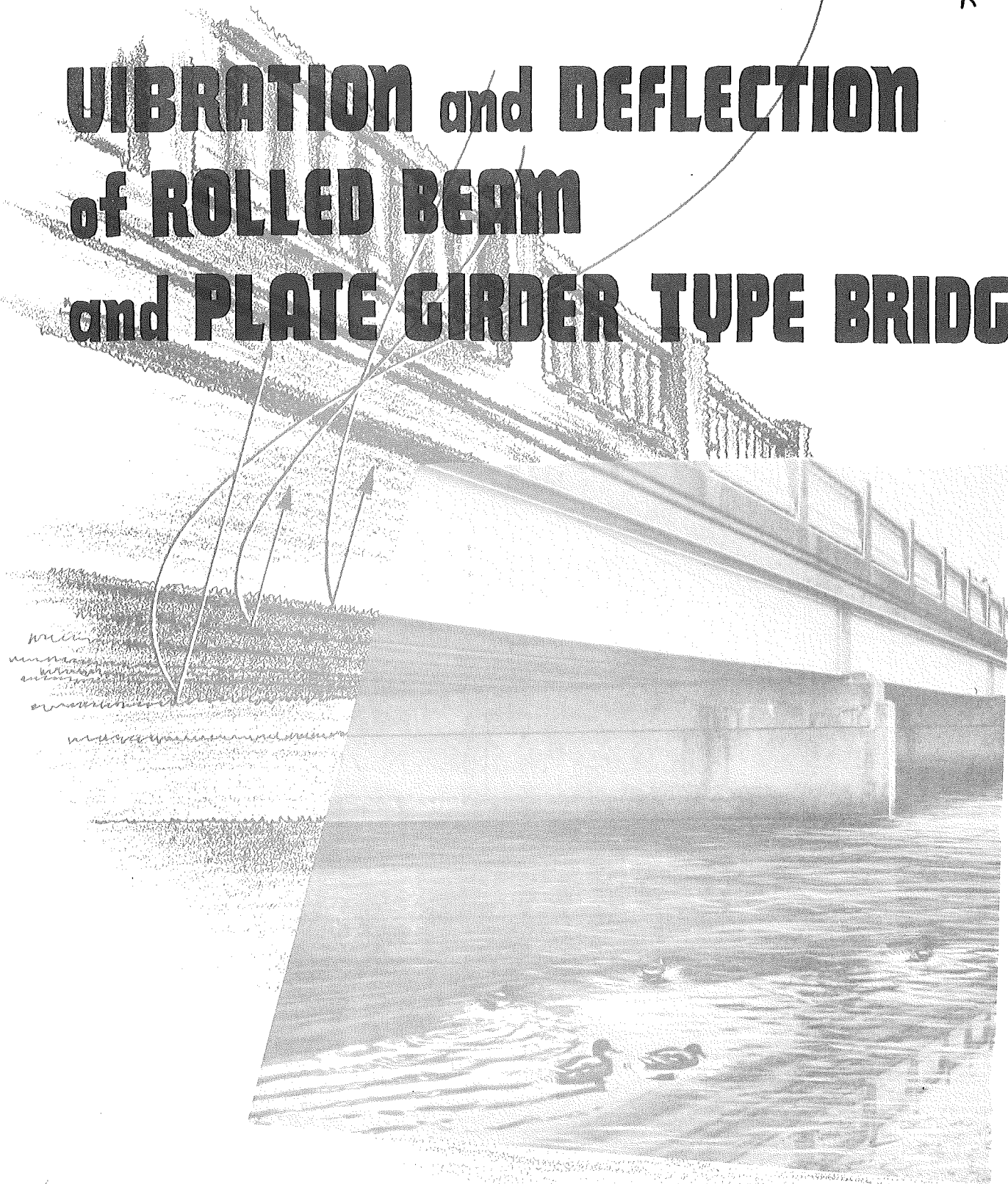

DECEMBER 1954

MICHIGAN
STATE HIGHWAY DEPARTMENT

CHARLES M. ZIEGLER
STATE HIGHWAY COMMISSIONER

LAST COPY
DO NOT REMOVE FROM LIBRARY

MICHIGAN
STATE HIGHWAY DEPARTMENT
Charles M. Ziegler
State Highway Commissioner

VIBRATION AND DEFLECTION OF ROLLED BEAM
AND PLATE GIRDER TYPE BRIDGES

By

George M. Foster
Chief Deputy Commissioner

and

LeRoy T. Oehler
Physical Research Engineer

Highway Research Project 52 F-24

Progress Report

This report is prepared for presentation
at the 34th Annual Meeting of the
Highway Research Board

Research Laboratory
Testing and Research Division
Report No. 219
December 15, 1954

TABLE OF CONTENTS

| | |
|--|----|
| I. INTRODUCTION | 2 |
| II. JACKSON BY-PASS BRIDGE | 3 |
| Description of Bridge Spans | 3 |
| Test Instrumentation | 5 |
| Test Procedure | 7 |
| Normal Loading, Commercial Trucks | 7 |
| Controlled Loading, Two-Axle Trucks | 8 |
| Controlled Loading, Three-Axle Truck | 10 |
| Test Results | 11 |
| Observed Deflections | 13 |
| Observed Deflections Compared to Theoretical Deflections | 13 |
| Maximum Amplitude of Vibration | 15 |
| Maximum Duration of Vibration | 15 |
| Observed Frequency of Vibration | 15 |
| Calculated Natural Frequency of Vibration | 19 |
| Damping of Free Vibration | 21 |
| Factors Influencing Vibration | 22 |
| Type of Truck, Axle Spacing, and Truck Speed | 22 |
| Gross Truck Load | 25 |
| Induced Impact | 26 |
| Other Factors | 29 |
| Discussion of Results | 30 |
| III. FENVILLE BRIDGE | 31 |
| Description of Bridge Spans | 31 |
| Test Instrumentation | 34 |
| Test Procedure | 34 |
| Controlled Loading, Two-Axle Trucks | 34 |
| Controlled Loading, Three-Axle Truck | 35 |
| Test Results | 35 |
| Observed Deflections | 35 |
| Observed Deflections Compared to Theoretical Deflections | 37 |
| Maximum Amplitude of Vibration | 40 |
| Maximum Duration of Vibration | 40 |
| Observed Frequency of Vibration | 41 |
| Calculated Natural Frequency of Vibration | 44 |
| Damping of Free Vibration | 45 |
| Factors Influencing Vibration | 45 |
| Type of Truck, Axle Spacing and Truck Speed | 45 |
| Induced Impact | 47 |
| Lateral Distribution of Deflections | 49 |
| Discussion of Results | 50 |
| IV. SUMMARY | 52 |
| Comparison of Two Bridges | 52 |
| General Findings | 52 |
| Findings Pertinent to Design Concepts | 53 |

VIBRATION AND DEFLECTION OF ROLLED BEAM
AND PLATE GIRDER TYPE BRIDGES

By
George M. Foster¹
and
LeRoy T. Oehler²

SYNOPSIS

This is a report covering observations made on the vibration and deflection characteristics on an eight-span plate girder bridge consisting of five simple spans and three spans of continuous beam design, and a continuation of the vibration and deflection studies on the Fennville Bridge, which was previously reported. The latter bridge consists of six simple spans of rolled beam construction with concrete decking. One of these spans was built with composite construction.

Three types of loading were used -- normal commercial truck traffic with a minimum of control, controlled testing with two-axle trucks, and controlled testing with a special three-axle truck with axle spacing identical to that for H20-S16 bridge loading.

Observations are reported on the frequency of vibration, the amplitude and duration of vibration, and the deflection for these spans under similar loading conditions. The lateral distribution of the vibration and deflection among the longitudinal beams is shown for several rolled beam spans.

A method is presented for calculating the natural frequency of a highway span which checks the observations within approximately three percent. The occurrence of appreciable vibration is correlated with the type, gross weight, axle spacing, and speed of the vehicle causing vibration. Other factors influencing vibration are discussed -- for example, the effect of vehicle sequence on vibrations and the effect of induced impact.

The differences in behavior of the various spans are correlated with present design criteria -- that is, "Design Live Load Plus Impact Deflection" and "Depth to Span Length Ratios".

¹ Chief Deputy Commissioner, Michigan State Highway Department
² Physical Research Engineer, Michigan State Highway Department

VIBRATION AND DEFLECTION OF ROLLED BEAM AND PLATE GIRDER TYPE BRIDGES

PART I. INTRODUCTION

Until quite recently studies of the deflection and vibration characteristics of bridges dealt chiefly with railroad bridges. Criteria for the proper design of highway bridges were adopted or modified on the basis of data and experience gathered on railroad structures. In two important points, impact and vibration, it might be expected that the inherent differences in the types of vehicles using the highway bridge as compared to the railroad bridge would influence the behavior of the structures. For example the "hammer-blow" effect in a railroad bridge has no counterpart in a highway structure.

The senior author of this paper, Chief Deputy Commissioner of the Michigan State Highway Department, and a member of the AASHO Committee on Deflection Limitations for Bridges, proposed that the Research Laboratory undertake a study of vibration and deflection on certain bridges in Michigan. Previous tests reported by him entitled "Michigan Test on Rolled Beam Bridge Using H20-S16 Loading" provided useful information on testing procedure and instrumentation which has been incorporated in this study. Mr. E. A. Finney, Assistant Testing and Research Engineer in Charge of Research, set up the general research program. Field tests and analysis of the data was under the supervision of the junior author. Paul Milliman, Physical Testing Engineer, supervised the operation and maintenance of the recording equipment.

The immediate aims of this investigation were to obtain data on the following items:

1. Measurement of overall deflection of each span under similar loading conditions.

2. Measurement of amplitude and frequency of vibration for each span under similar loading conditions.
3. Determination of the effect of overall vehicle weight, type of vehicle, axle arrangement, vehicle speed and impact on vibration and deflection.

This report describes the methods used in carrying out these objectives on the Jackson By-Pass Bridge (B1 & X 1 of 38-1-4), an eight-span plate girder structure, and the Kalamazoo River Bridge near Fennville (B1 of 3-9-12), a six-span rolled beam structure; the results obtained; and certain comparisons with theoretical values or design criteria.

PART II. JACKSON BY-PASS BRIDGE

Description of Bridge Spans

This structure is composed of simple and continuous spans of plate girder construction with a concrete deck. Fundamental information on this bridge is shown in Figure 1. The north and south roadways with their accompanying sidewalks and raised median wheel guards are independent superstructures for all spans, but the two roadways share common piers and abutments. Each roadway is supported by six lines of plate girder beams which are 4 ft. - 2-1/2 in. back-to-back of angles, with one full length and one variable length cover plate on top and bottom flanges, for all beam spans. Five, or in some cases six rows of diaphragms connect the plate girders together transversely. The deck is constructed of reinforced concrete with variable slab thickness to provide the required crown at the center and to allow for dead load deflection of the beams.

The first four spans have a 90-degree angle of crossing, but the last four spans are on a 1-1/2 degree curve. This bridge is also constructed on a vertical curve.

The fundamental differences between the eight spans are as follows:

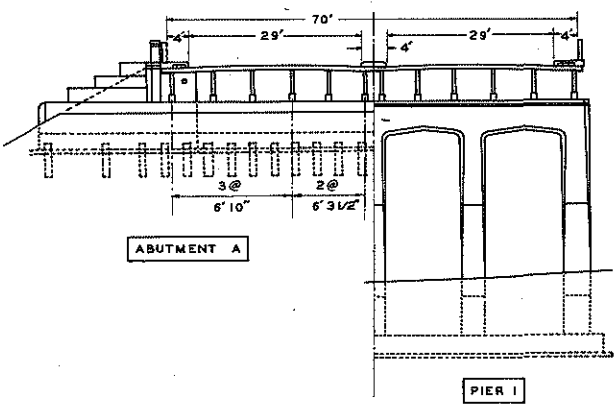
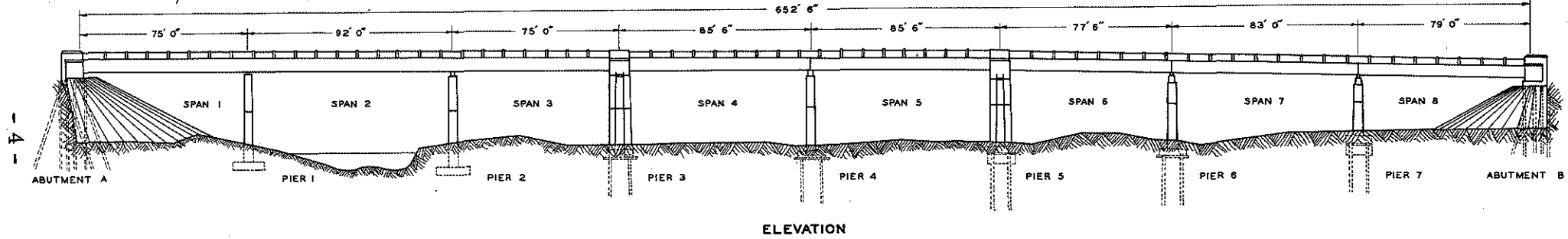
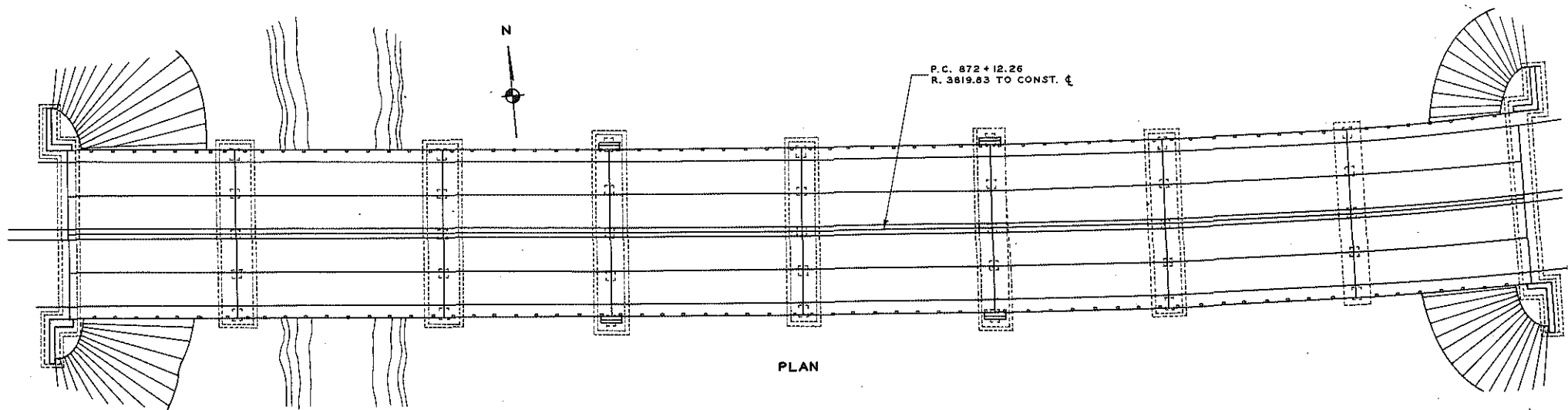

FIGURE I
GENERAL PLAN OF STRUCTURE
JACKSON BY-PASS BRIDGE
BI & XI OF 38-1-14

Span 1 - West end span of a three-span continuous superstructure with a span length of 72 ft. 6 in. , center to center of bearings.

Span 2 - Center span of a three-span continuous superstructure with a span length of 92 ft. 0 in.

Span 3 - East end span of a three-span continuous superstructure with a span length of 74 ft. 4-1/2 in.

Span 4 - Simple span of 84 ft. 3 in. length.

Span 5 - Simple span of 84 ft. 3 in. length on horizontal curve.

Span 6 - Simple span of 76 ft. 3 in. length on horizontal curve.

Span 7 - Simple span of 81 ft. 9 in. length on horizontal curve.

Span 8 - Simple span of 76 ft. 1-1/2 in. length on horizontal curve.

This structure was subjected to three types of traffic to effect vibrations and deflections: (1) normal truck traffic with a minimum of control; (2) two-axle county maintenance trucks; and (3) the special three-axle highway department bridge test truck. The second and third types were used under controlled conditions to study the influence of certain factors on vibration. Since the electronic instrumentation was common for all types of loading, it will be described first, followed by a description of the methods and procedures used for the three types of traffic.

Test Instrumentation

Deflectometers to record bridge movement were built in the Highway Research Laboratory. These deflectometers were fastened rigidly to the center safety curb or median strip at the center of each span, as shown in Figure 2. With deflection of the bridge, the dial gage moved with the bridge as did the entire deflectometer assembly, with the exception of the end of the hinged cantilever beam which was held from below by a tightened wire attached to a 100-pound weight on the ground (see Figure 3) and above by a stretched spring. The movement of the bridge could be noted visually

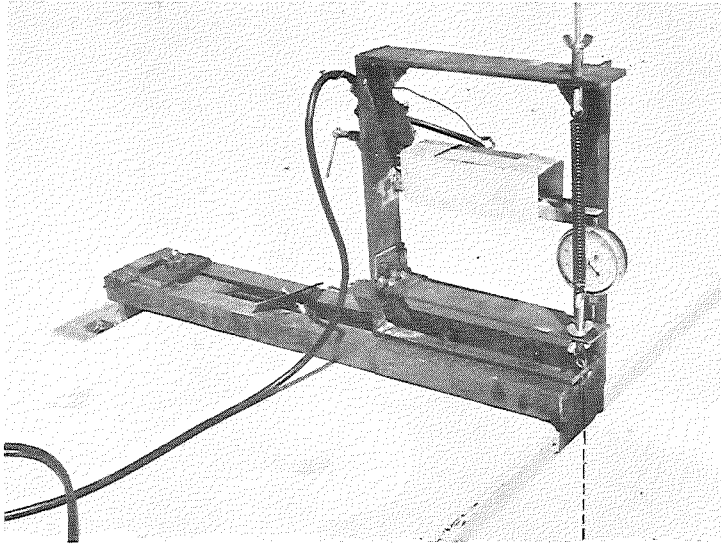

▲ FIGURE 2-DEFLECTOMETER USED TO MEASURE THE VIBRATION AND DEFLECTION AT THE CENTER OF THE SPAN

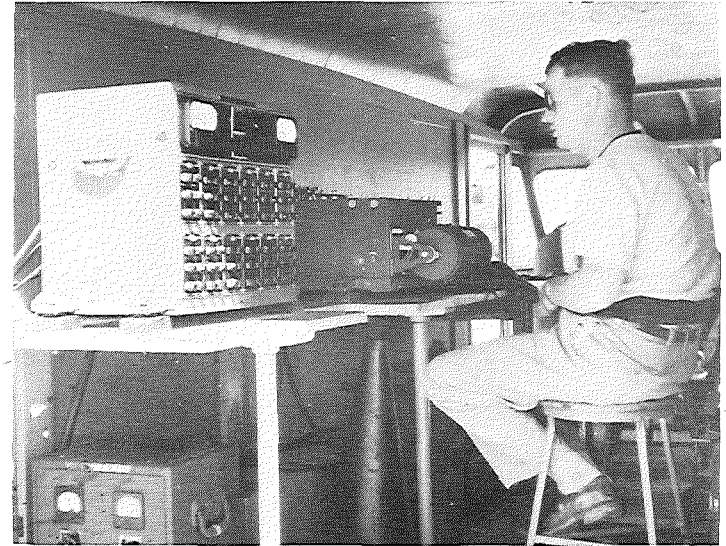

▲ FIGURE 4-HATHAWAY RECORDING OSCILLOGRAPH

FIGURE 3-WIRE, TURNBUCKLE AND 100-POUND WEIGHT USED FOR THE PURPOSE OF HOLDING THE HINGED CANTILEVER BEAM IN POSITION

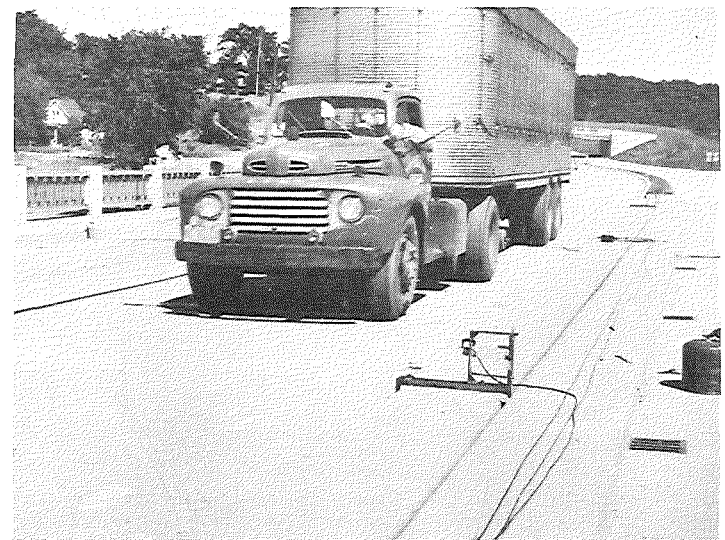
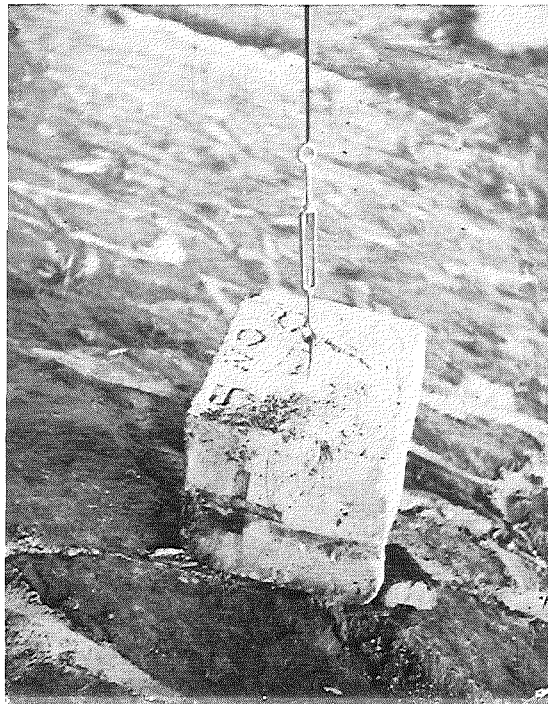

▲ FIGURE 5- A COMMERCIAL TEST TRUCK PASSING OVER THE BRIDGE

by reading the dial gage, but a permanent record was also obtained by means of a wire resistance strain gage fastened to an aluminum cantilever beam which was deflected by the top end of the dial gage stem. Change in the electrical resistance of the strain gage was a measure of the strain in the aluminum cantilever and this change in electrical resistance resulted in a deflection of a light trace on a photo-sensitive paper strip in a Hathaway 12-channel recording oscillograph. The Hathaway equipment is shown in Figure 4. A calibration of the dial deflection corresponding to a given trace deflection was made by moving each of the hinged cantilever beams a given amount and noting the movement on the corresponding trace prior to the beginning of testing. An indication of the truck speed and the time that the truck was on each successive span was obtained by means of traffic counter cables which gave a pip on an inactive oscillograph trace when the truck tire passed over the cable.

It was initially intended that the deflections on eight spans would be taken simultaneously and thus a direct comparison could be made between all spans. However, during the installation of the electronic equipment it was found impossible to balance out the capacitance of the lead wires when they were over 150 feet long. Therefore, test data was gathered on four spans at one time - either Spans 1 through 4 or Spans 5 through 8.

Test Procedure

Normal Loading, Commercial Trucks: Data on deflections and vibrations of this bridge were obtained for normal truck traffic under the following testing procedure. At the Jackson Weighing Station, east of the bridge, the trucks were selected which would be passing over the test bridge. These were assigned test numbers, and axle loads and axle spacing measurements were obtained. At a convenient distance from the bridge, the test trucks were stopped, the test truck numbers obtained, and

the driver was instructed to follow the painted stripe on the bridge which would place the center of the dual wheels on the load axles at 2 feet from the curb face of the center median strip. They were further instructed to travel over the bridge at approximately 35 mph. However, the east approach to the bridge has sufficient grade to prevent some trucks from reaching the desired speed. As the truck approached the test spans, the recording equipment was switched on and the data on vibrations and deflections were obtained for four of the eight spans at one time (see Figure 5). Sixty-four trucks were used for this phase of the study. These trucks varied from two-axle to six-axle vehicles with a distance between extreme axles of 11.2 to 51.2 feet. The gross weight of these vehicles varied from 5.3 to 75.3 kips and the speed range was from 16 to 42.9 mph.

Controlled Loadings, Two-Axle Trucks: In the controlled loading study, four county maintenance trucks were loaded and driven over the bridge at varied speeds, with and without boards on the spans to induce impact, and in definite sequence in certain cases, in an attempt to study some of the factors influencing vibration. All of these trucks were of the two-axle type with axle spacings of 13.4 to 14.7 feet and gross weights of 26.5 to 28.1 kips. Essential data on these trucks is given in Figure 6. The measurement of the static deflection was made for each span with each of the trucks respectively in the proper position on the span for the maximum effect. Previous to this testing phase, theoretical calculations of the natural frequency of the various spans had been made and the data on vibrations from the normal truck traffic had also been utilized to determine the natural frequency of the spans. Knowing the axle spacing of each truck, it was possible to calculate the speed for each truck for any given span, which would cause the time interval between the first and second axle of the truck passing any given point to be equal to the natural period of

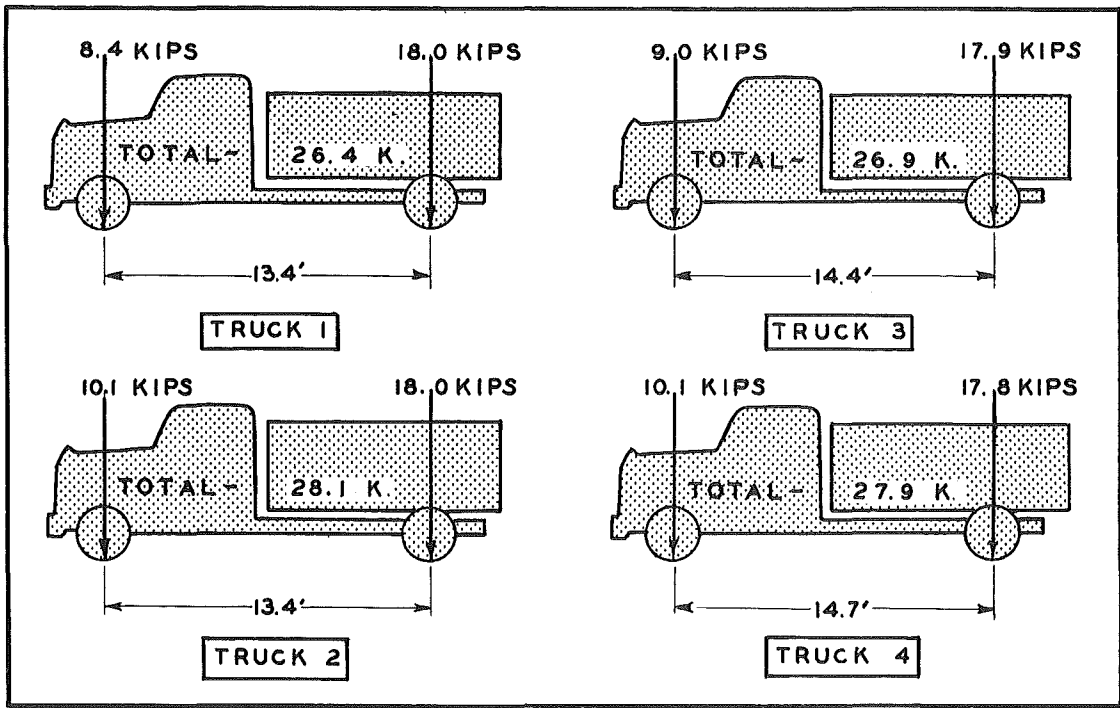
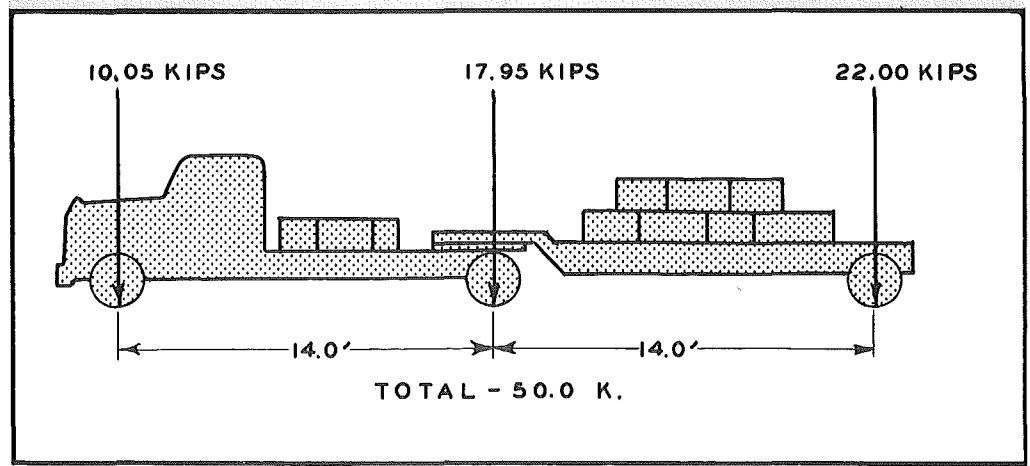

FIGURE 6-
LOADING DIAGRAM
OF FOUR COUNTY
MAINTENANCE
TRUCKS USED FOR CON-
TROLLED LOADING TESTS
ON FENVILLE BRIDGE.

FIGURE 7 - A PHOTO-
GRAPH AND LOADING
DIAGRAM FOR THE
THREE-AXLE WALTERS
TEST TRUCK.



vibration of the span. This might result in a tendency to set up resonant vibrations in the span. (1)*

It was intended that the trucks be driven over each span at speeds which might induce resonant vibrations (approximately 50 mph., but it varied with the axle spacing of the trucks and the natural frequency of the bridge spans) and at speeds more and less than this by 5 mph. However, only two of the trucks approached the calculated speeds and their speeds were generally 2 to 5 mph. less than required. In addition, tests were made with three vehicles in sequence with approximately twice the average axle spacing between vehicles. This was accomplished by placing the vehicles in line with ropes between, so that the drivers could gauge the distance apart of the vehicles by watching the sag in the ropes. The purpose of these runs was to establish a greater number of axle load repetitions which would be in phase. Also, tests were run with two trucks traveling across the bridge side by side. In both sets of tests just mentioned, the actual speeds were approximately 10 mph. less than the calculated resonant speed. Certain tests were also run with 3/4-inch and 1-5/8-inch impact boards on the spans in order to measure the influence of these boards on the vibration of the spans.

Controlled Loading, Three-Axle Truck: In the third phase of field testing, a three-axle truck was used under controlled conditions to extend the study begun with the county maintenance trucks. A photograph and loading diagram of this vehicle is shown in Figure 7. One unique part of this testing was the simultaneous recording of strains on the rear axle of the truck tractor with the bridge vibrations and deflections. This was done in an attempt to correlate the load variations, as reflected by axle strains as the truck passed over the bridge, with the bridge oscillations. Electrical strain gages attached to the axle indicated the variations in load on the axle and this was recorded permanently by means of a Brush oscillograph. Axle strains were previously calibrated with load variation, for as the truck was loaded with known loads,

(1)* Please refer to Bibliography

the strain gages were read by the use of an SR-4 Strain Indicator. It was realized from the beginning that this truck had a very limited speed and, therefore, no attempt was made to obtain a speed which might induce resonant vibrations. This would have required a speed of approximately $5.5 \times 14.0 = 77$ ft. per second, or 52.5 mph. Instead, three runs were made at each of the following speeds: creep, 15, 20, 25, and 30 mph. Also, test runs were made at approximately 10 and 20 mph. over 3/4-inch boards placed on Spans 2, 4, 5, and 7 to induce impact, and at 10, 15, 20, and 25 mph. over 1-5/8-inch boards on the same spans.

Test Results

The oscillograph traces which recorded the movement of the center of the bridge spans gave a permanent record of the bridge vibration and deflection. These traces were studied to determine the magnitude of the bridge deflections and vibrations and to determine the factors which influenced vibration.

Table 1 contains information on the eight spans and two common design factors - that is, "Ratio of Depth to Span Length of Girders;" and the "Design Live Load Plus Impact Deflection." In addition, the observations on the maximum deflection, amplitude of vibration, and duration of vibration are shown. The amplitude of vibration while the truck was on the span (span loaded) and off the span (span unloaded) is treated separately. The maximum amplitudes of vibration are based only on trials without induced impact effects because under the effect of impact, much greater amplitudes resulted.

For this study it was necessary to separate the effects of bridge deflection and bridge vibration and, therefore, the deflection values given were obtained from the oscillograph trace by ignoring the periodic oscillation due to vibration and thus they represent the "crawl" deflection or static deflection only.

Table 1. Summary of Observations on Maximum Deflection and Maximum Amplitude and Duration of Vibration

| Data on Spans | Ratio of Depth to Span Length | Design Live Load Plus Impact Deflection in In. | Max. Deflection in Inches | Max. Amplitude of Vibration in Inches (Without Induced Impact Effect) | | Max. Duration of Vibration in Seconds After Truck is Off The Span |
|---|-------------------------------|--|----------------------------------|---|--|---|
| | | | | Span Loaded | Span Unloaded | |
| 1. Continuous Span 72'-6" in length | 1/17.2 | ---- | 0.090 due to "2S1-2" truck | 0.015 due to "2S1" truck | 0.009 due to three 2- axle trucks in sequence | 29 due to special 3- axle test truck with induced impact |
| 2. Continuous Span 92'-0" in length | 1/21.9 | 1.05 or 1/1050 of span | 0.094 due to "2S1-2" truck | 0.018 due to "2S1" truck | 0.017 due to "2S1" truck | 23 due to special 3- axle test truck with induced impact |
| 3. Continuous Span 74'-4-1/2" in length | 1/17.7 | ---- | 0.068 due to "2S2" truck | 0.014 due to "3" truck | 0.011 due to "2S1-2" truck | 18 due to special 3- axle test truck with induced impact |
| 4. Simple Span 84'-3" in length | 1/20 | 0.94 or 1/1080 of span | 0.097 due to "2S2" truck | 0.021 due to "3" truck | 0.009 due to "2S1" truck | 14 due to special 3- axle test truck with induced impact |
| 5. Simple Span Approx. 84'-3" | 1/20 | 0.94 or 1/1080 of span | 0.135 due to "2S1-2" truck | 0.030 due to "2-2" truck | 0.012 due to "2S1-2" truck | 22 due to special 3- axle test truck with induced impact |
| 6. Simple Span Approx. 76'-3" in length | 1/18.1 | 0.82 or 1/1120 of span | 0.106 due to "2S1-2" truck | 0.016 due to "2S2-2" truck | 0.008 due to "2S1-2" truck | 22 due to special 3- axle test truck with induced impact |
| 7. Simple Span Approx. 81'-9" in length | 1/19.4 | 0.89 or 1/1100 of span | 0.112 due to "2S1-2" truck | 0.020 due to "2S2" truck | 0.006 due to "2S1-2" truck | 11 due to special 3- axle test truck |
| 8. Simple Span Approx. 76'-1-1/2" in length | 1/18.1 | 0.82 or 1/1120 of span | 0.081 due to "2-2" truck | 0.020 due to "2S2" truck | 0.0025 due to two 2- axle truck side by side | 8 due to special 3- axle test truck with induced impact |

Observed Deflections: Maximum deflections for each span occurred as a result of normal truck traffic. Span 5 deflected the most (0.135 inch) due to a single 2S1-2 type truck with an axle length of 36.2 feet and a total load of 70.4 kips. Since Spans 1 through 4 were subjected to one group of commercial trucks and Spans 5 through 8 to another set, the maximum deflection of Span 4 under normal loading was not as great as Span 5, although these spans are structurally almost identical.

Observed Deflections Compared to Theoretical Deflections: The maximum observed deflection for Span 5 was only 14.4 percent of the deflection value for "Design Live Load Plus Impact," but it should be remembered that for design, lane live-load rather than the standard truck is used for a span of this length, and both lanes are loaded. Calculations indicate that theoretically (neglecting the stiffening effect of the concrete deck as is customary) this truck would cause a deflection of 0.312 inch. The special three-axle test truck caused a deflection on this span of 0.093 inch while similar calculations would indicate a deflection of 0.216 inch. Actual deflections are thus 43 percent in each case of the calculated deflections.

Table 2 compares the actual deflection with the theoretical deflection for the single spans and the continuous structure. The ratio of actual to theoretical deflection varies from 39 to 43 percent for the single spans and is 38 percent for the three-span continuous structure.

It will later be shown that the concrete deck, acting with the steel plate girders, not only has a tendency to reduce the actual deflection but its stiffening effect is also reflected in the natural frequency of vibration of the spans.

It is interesting to compare the resulting deflections for the various simple spans, caused by a given vehicle and to correlate this with the two design considerations of "Depth to Span Length Ratio" and the "Calculated Design Live Load Plus

TABLE 2

Comparison of Actual to Theoretical Deflection for
Jackson Bridge Spans, (Special three-axle test truck)

| Span | Actual Deflection - Inches | Theoretical Deflection - Inches | Ratio Actual/ Theoretical |
|------|----------------------------------|---------------------------------------|---------------------------------|
| 2 | 0.087 | 0.228* | 0.38 |
| 4 | 0.093 | 0.216 | 0.43 |
| 5 | 0.093 | 0.216 | 0.43 |
| 6 | 0.075 | 0.193 | 0.39 |
| 7 | 0.086 | 0.212 | 0.41 |
| 8 | 0.078 | 0.193 | 0.40 |

* For this three-span continuous structure, the effect of short additional cover plates over the center supports was neglected.

Impact Deflection" values. This has been done in Figures 8 and 9 which illustrate that nearly linear relationships do exist in this correlation as should be expected.

Maximum Amplitude of Vibration: The maximum amplitude of vibration for the various spans, for span loaded and unloaded, was caused by a commercial truck, in every case but one. Span 5 had the maximum amplitude of vibration with the truck on the span, 0.030 inch (see Figure 10). However, the maximum amplitude of vibration - span unloaded (0.017 inch) - occurred on Span 2, the center span of the three-span continuous structure, due to a 2S1 truck (see Figure 11). The oscillograph trace shown in Figure 11 should be studied in detail because it represents one of the best examples of harmonic vibration which was obtained in this study. All three spans of the continuous structure were vibrating regularly, with Spans 1 and 3 180 degrees out of phase with Span 2. The duration of this vibrating motion is also worthy of note. Suggestions as to the cause of this unusual example of vibration will be discussed under Factors Influencing Vibration. In Figure 12, the relation for simple spans of the maximum observed amplitude of vibration, span unloaded, for the special three-axle test truck, is plotted against the "Depth to Span Length Ratio".

Maximum Duration of Vibration: The maximum duration of vibration (29 seconds) occurred on Span 1, a part of the three-span continuous structure, due to the special three-axle test truck running over a 1-5/8-inch thick board placed on Span 2 to cause an impact effect (see Figure 13). In every case but one, the maximum duration of vibration for each span occurred in this way. Span 1, however, vibrated in one case 25 seconds due to the special three-axle test truck passing over the bridge without induced effects.

Observed Frequency of Vibration: For all spans except Span 8, the use of the normal truck traffic and the two types of controlled loading effected sufficient occurrences of uniform harmonic vibration to obtain the natural frequency of these spans.

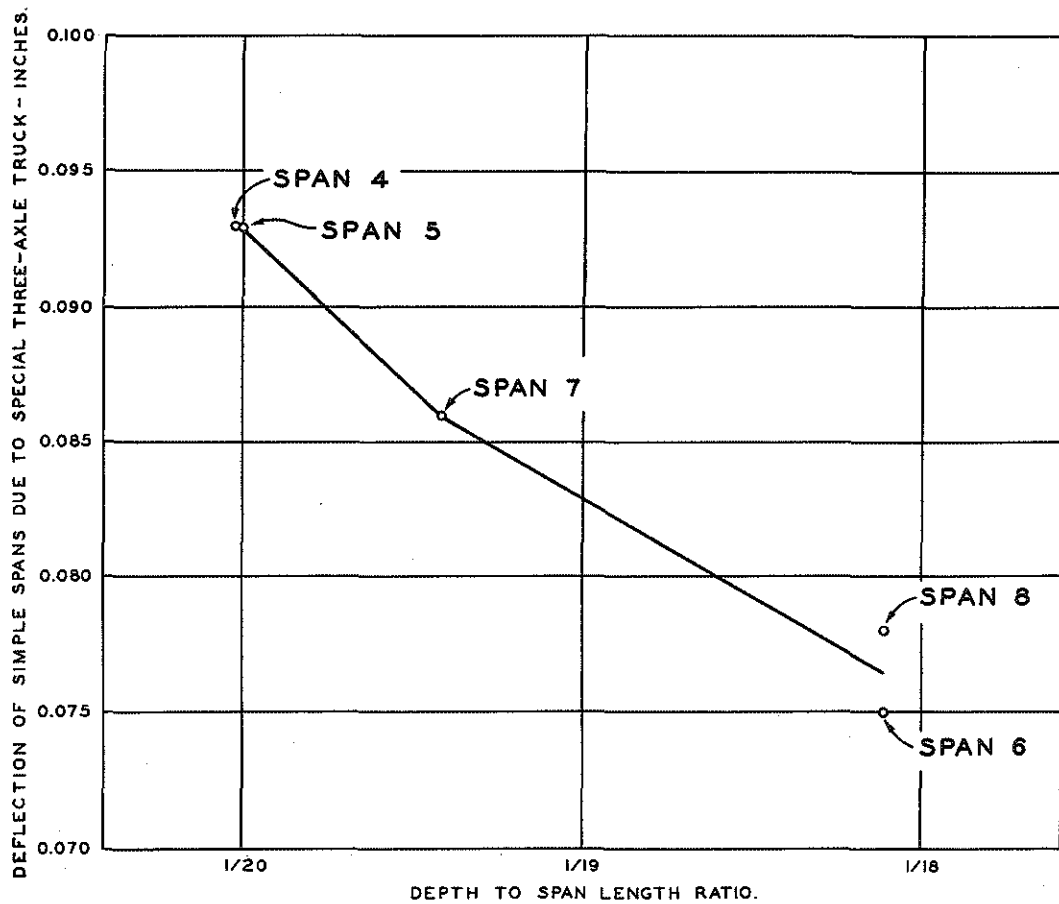

FIGURE 8

RELATION BETWEEN OBSERVED DEFLECTION AND DEPTH TO SPAN LENGTH RATIO (SPECIAL THREE-AXLE TEST TRUCK).

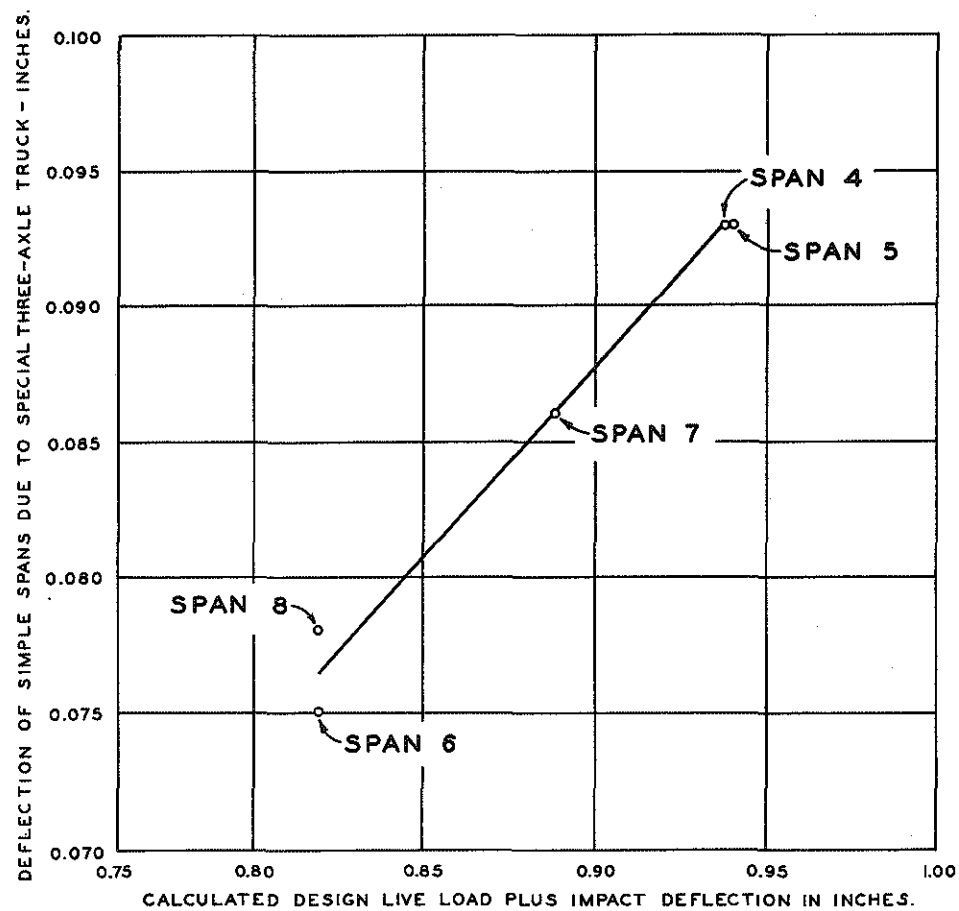
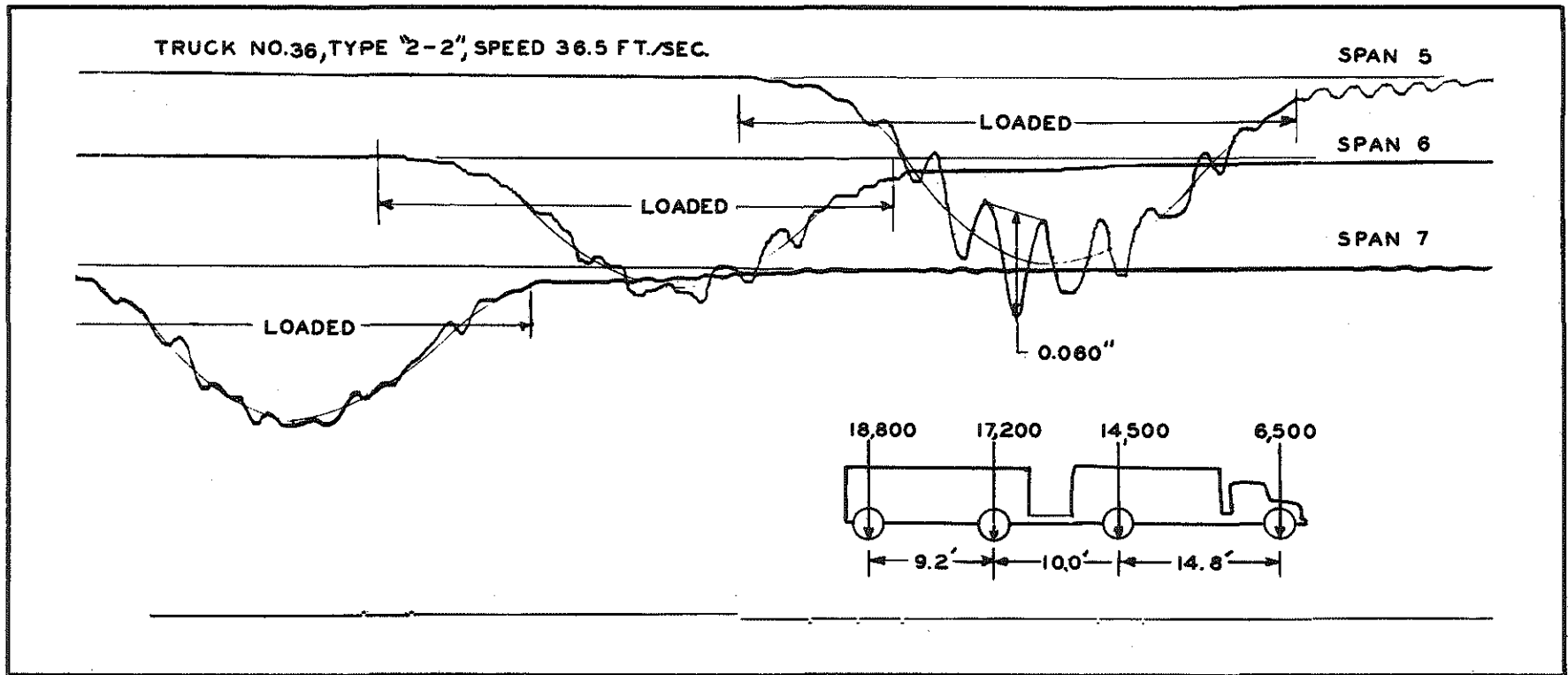
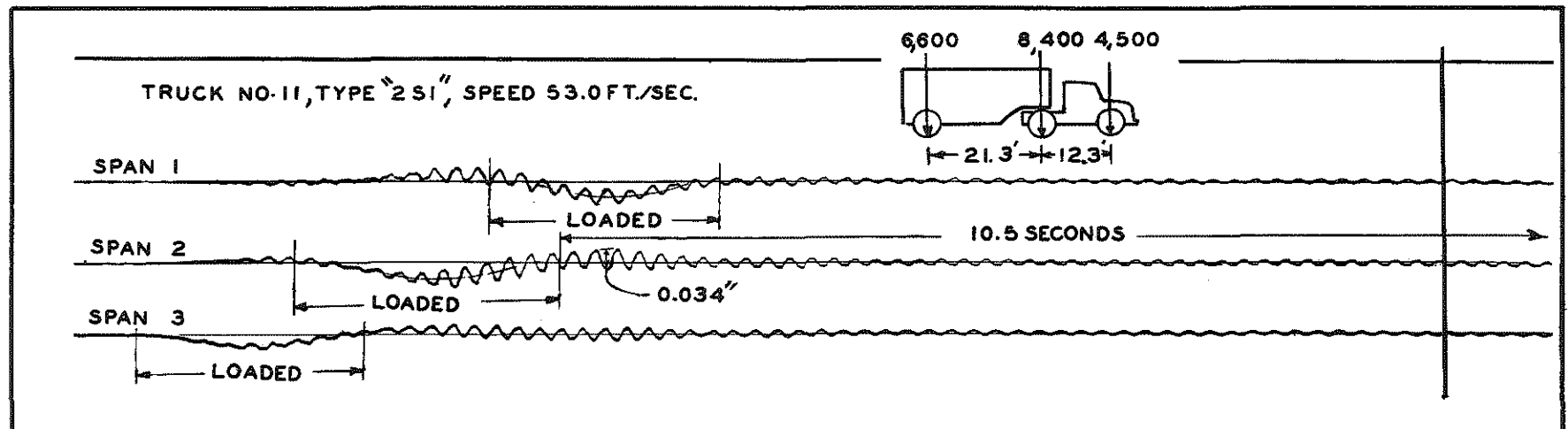

FIGURE 9

RELATION BETWEEN OBSERVED DEFLECTION AND CALCULATED DESIGN LIVE LOAD PLUS IMPACT DEFLECTION (SPECIAL THREE-AXLE TEST TRUCK).



▲ FIGURE 10 - OSCILLOGRAPH TRACE SHOWING MAXIMUM AMPLITUDE OF VIBRATION WHILE SPAN WAS LOADED



▲ FIGURE 11 - OSCILLOGRAPH TRACE SHOWING MAXIMUM AMPLITUDE OF VIBRATION - SPAN UNLOADED

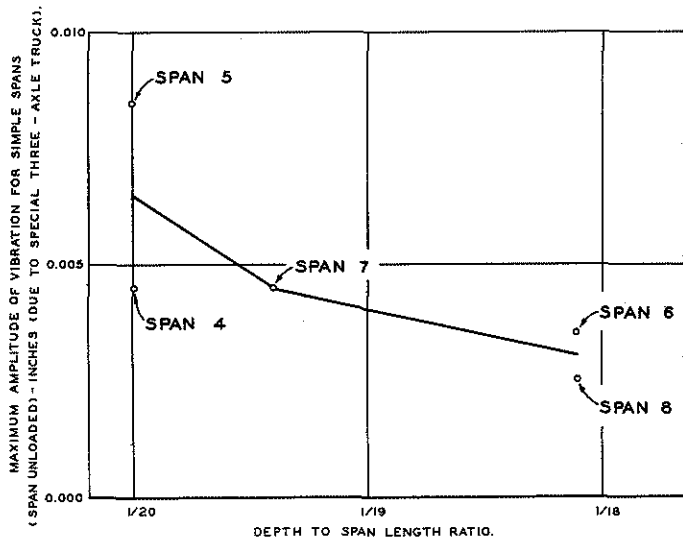

▲ FIGURE 12

RELATION BETWEEN OBSERVED MAXIMUM AMPLITUDE OF VIBRATION AND DEPTH TO SPAN LENGTH RATIO FOR SIMPLE SPANS.
(SPECIAL THREE-AXLE TEST TRUCK)

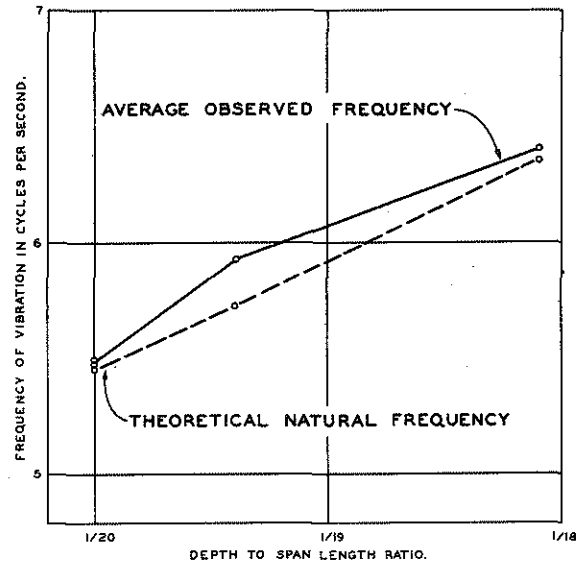

▲ FIGURE 14

AVERAGE OBSERVED FREQUENCY AND THEORETICAL NATURAL FREQUENCY OF VIBRATION COMPARED TO RATIO OF DEPTH TO SPAN LENGTH-FOR SIMPLE SPANS.

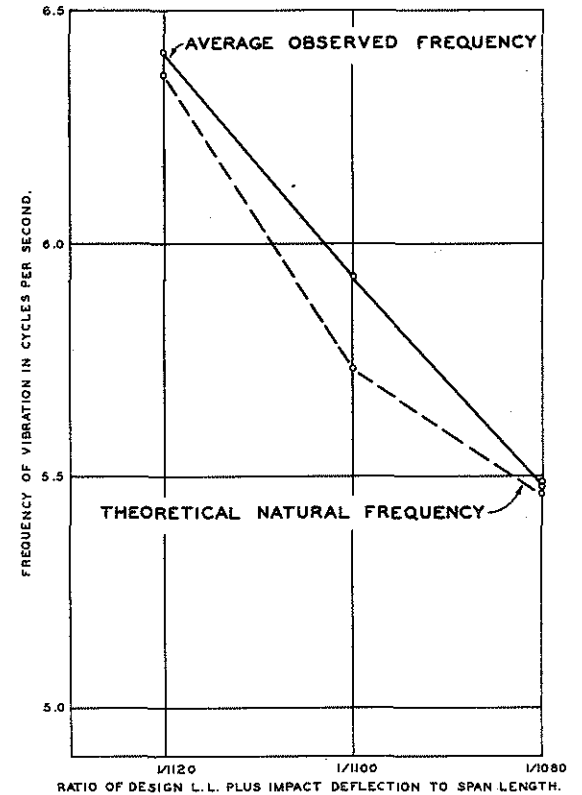

▲ FIGURE 15

AVERAGE OBSERVED FREQUENCY AND THEORETICAL NATURAL FREQUENCY OF VIBRATION COMPARED TO RATIO OF DESIGN LIVE LOAD PLUS IMPACT DEFLECTION TO SPAN LENGTH

OSCILLOGRAPH TRACE SHOWING MAXIMUM DURATION OF VIBRATION

▼ FIGURE 13

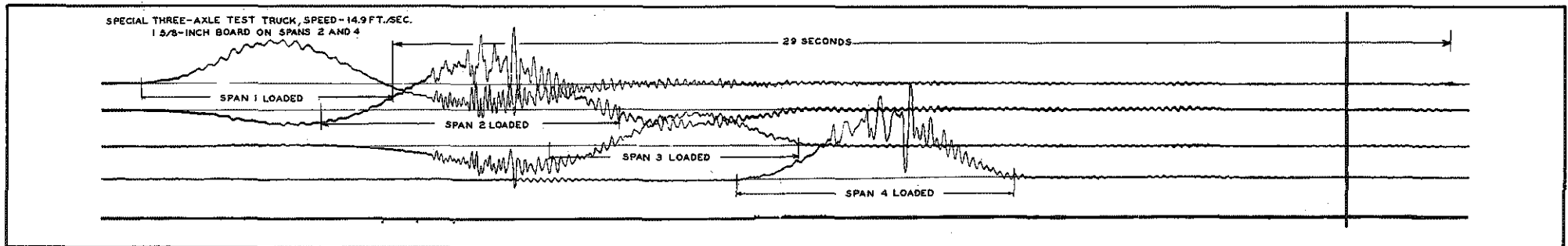

To obtain the values for the Average Observed Frequency of Significant Vibrations, given in Table 3, only those cases were used where at least ten cycles of steady vibration had occurred. This eliminated cases where a few cycles of random vibration occurred which were markedly different in frequency from the natural frequency of vibration for the span. As a result, the observed values were very uniform and compare very well with the Theoretical Natural Frequency of Vibration for the spans.

Calculated Natural Frequency of Vibration: In calculating the theoretical frequency, an effective cross-section was used which included the two steel plate girders most affected by the passage of the truck, and 50 percent of the concrete deck above these two plate girders, which was considered as acting partially with the girders in composite action. These spans were not designed for composite action since shear developers were not used, but results of previous tests already published⁽²⁾ have shown that the concrete deck does act to a limited extent as a part of the effective cross-section.

The formula for the natural frequency of a simple beam with a uniform load is:

$$f = \frac{\pi}{2 L^2} \sqrt{\frac{g E I}{W}}$$

where:

$$\pi = \text{pi} = 3.1416$$

L = length of span in inches

g = acceleration of gravity = 386 inches per second, per second

E = modulus of elasticity of the material which was assumed as follows:

E for steel = 30×10^6 psi.

E for concrete = 5×10^6 psi.

Table 3. Summary of Observations on Frequency of Vibration

| Data on Spans | Ratio of Depth to Span Length | Design Live Load Plus Impact Deflection in In. | Average Frequency of Significant Vibrations in Cycles/Sec. * | | | | Theoretical Natural Frequency of Vibration in Cycles/Second | % Difference of Theoretical to Observed Frequency |
|---|-------------------------------|--|--|--------------------|------------------|------------------|---|---|
| | | | Normal Loading | Controlled Loading | | Average | | |
| | | | | 2-axle Trucks | 3-axle Truck | | | |
| 1. Continuous Span 72'-6" in length | 1/17.2 | ---- | 5.13 | 5.22 | None Significant | 5.18 | ---- | --- |
| 2. Continuous Span 92'-0" in length | 1/21.9 | 1.05 or 1/1050 of Span | 5.15 | 5.26 | 5.25 | 5.22 | 4.86 | 6.9 |
| 3. Continuous Span 74'-1-1/2" in length | 1/17.7 | ---- | 5.14 | 5.25 | None Significant | 5.20 | ---- | ---- |
| 4. Simple Span 84'-3" in length | 1/20 | 0.94 or 1/1080 of Span | 5.48 | 5.52 | 5.46 | 5.49 | 5.46 | 0.6 |
| 5. Simple Span approx. 84'-3" in length | 1/20 | 0.94 or 1/1080 of Span | 5.40 | 5.50 | 5.52 | 5.47 | 5.46 | 0.2 |
| 6. Simple Span approx. 76'-3" in length | 1/18.1 | 0.82 or 1/1120 of Span | 6.30 | 6.60 | 6.34 | 6.41 | 6.36 | 0.8 |
| 7. Simple Span approx. 81'-9" in length | 1/19.4 | 0.89 or 1/1100 of Span | 5.93 | 6.01 | 5.85 | 5.93 | 5.73 | 3.4 |
| 8. Simple Span approx. 76'-1-1/2" in length | 1/18.1 | 0.82 or 1/1120 of Span | None Significant | None Significant | None Significant | None Significant | 6.38 | --- |

NOTE: * - The average of test runs where at least 10 cycles of continuous vibration occurred after the truck had passed over the span.

I = moment of inertia of the effective cross-section in inches⁴.

W = weight of the uniform load in pounds per inch.

In calculating the natural frequency of vibration for the spans, the variation in moment of inertia, due to the cover plates, was roughly taken into account by assuming that the moment of inertia at the center half of the span was 20 percent greater than at the ends of the span, which is approximately true.

The difference between the theoretical and observed frequency was greatest for the three-span continuous structure but, for the simple spans, the largest difference was only 3.4 percent and the average difference for the simple spans only 1.2 percent. Figures 14 and 15 show the relation between the Average Observed Frequency of Vibration for the simple spans as compared to the "Ratio of Depth to Span Length", and the "Ratio of Design Live Load Plus Impact Deflection to Span Length",

Damping of Free Vibration: It is interesting to compare the damping of the free vibration for the various spans. A study of the decay in vibrations shows that the damping is very like Coulomb damping or friction damping, rather than the more conventional viscous damping. Calculating the damping coefficients from experimental data on the basis of friction damping would be laborious and certain assumptions would be necessary. However, the damping coefficients may be calculated readily on the basis of viscous damping without additional assumptions and with an accuracy sufficient for the purpose of comparing the various spans.

The damping coefficient may be computed from experimental data by the following equation:

$$S = \frac{\ln A_0 - \ln A_n}{2\pi n}$$

where S = damping coefficient

A_0 = amplitude of initial vibration
 A_n = amplitude of nth cycle of vibration
 n = number of cycles

Table 4 shows the damping coefficients for the spans as obtained from a study of oscillograph traces of prominent vibrations.

Factors Influencing Vibration

Type of Truck, Axle Spacing, and Truck Speed: The type of truck appears to have an effect on bridge vibration inasmuch as the axle spacing in combination with the truck speed influences the time period between axles passing a given point on the bridge span. This time period between axles, when related to the period of natural frequency of the structure, apparently affects the amplitude and duration of vibration. In the case of a two-axle truck, the speed of the truck can be determined so that this time interval between the passage of the first and second axle is equal to the natural period of vibration of the bridge span. For commercial vehicles with more than two axles and non-uniform axle spacings, this time period between axles varies. If these time periods vary markedly, we might expect a counter effect and a decrease in the amplitude of vibration.

Data gathered with the use of commercial trucks will first be used to discuss the significance of this timing. The maximum amplitude of free vibration (when the truck had passed off the span) and maximum duration of vibration for the continuous spans was caused by the passage of Truck No. 11 (see Figure 11). The next most significant vibration occurred due to Truck No. 8. Both trucks were of the 2S1 type and the speed and axle spacing between axles 2 and 3 gave a time period between axles of 0.397 and 0.401 seconds. The natural period of vibration of this structure is 0.191 seconds, or approximately one-half of the time period between axles.

The other type of truck which caused the greatest amplitude and duration of

TABLE 4

Damping Coefficients of Vibration. Jackson By-Pass Bridge.

| <u>Span</u> | <u>Type</u> | <u>Damping Coefficient</u> |
|-------------|------------------------------------|----------------------------|
| 2 | Three-span continuous plate girder | 0.004 |
| 4 | Simple span plate girder | 0.012 |
| 5 | Simple span plate girder | 0.009 |
| 6 | Simple span plate girder | 0.010 |
| 7 | Simple span plate girder | 0.011 |
| 8 | Simple span plate girder | --- |

free vibration was the 2S1-2. In general, the spacing of axles for this type is quite uniform. Truck No. 66 (2S1-2 type) caused the most significant vibrations on Spans 5 and 6, and the time periods between axles were as follows: (axle 1-2) 0.223, (axle 2-3) 0.182, (axle 3-4) 0.173, (axle 4-5) 0.170 seconds. These time intervals are very close to the natural period for this span, which is 0.183 seconds. Another truck which caused significant vibrations on this span was No. 26 (2S1-2 type) with time intervals between axles of 0.228, 0.185, 0.195 and 0.189 seconds. On Span 6, Truck No. 66 was the most effective while No. 64 (2S1-2 type) was second. The time intervals between axles for the latter truck were 0.190, 0.183, 0.161, and 0.175 seconds, while the natural period for the span was 0.156 seconds. Again, another 2S1-2 type truck caused the maximum duration of vibration on Span 7 with time intervals of 0.228, 0.185, 0.194 and 0.189 seconds between axles as compared to the natural period for this span, which is 0.169 seconds.

In studying the test data it appears that when this time interval between axles is nearly equal to or, in some cases, approximately one-half of the natural period of the structure, the vibrations are greater in amplitude and longer in duration. In connection with this, the uniform or nearly uniform axle spacing plays an important part for trucks with more than two axles. Generally, the importance of the first time interval between axle 1 and 2 is least, while the time between the last two axles is most important. There may be other variables besides the time interval between axles which play an important part in influencing vibration but this factor did seem to predominate.

The data gathered under controlled loading with two-axle trucks did not appear to reinforce the remarks made in the previous paragraph. There may be two reasons for this. First, the two-axle trucks were driven at maximum speed but the

time interval between axles was always somewhat greater than the natural period of the bridge spans. Second, the trucks were loaded with approximately one-third of the total load on the front axle and two-thirds on the rear axle and thus the influence of the front axle may have been slight.

For controlled loading with the special three-axle truck, it was realized at the outset that it would not be possible to obtain sufficient speed to attest the previous remarks and, therefore, a considerable range in speed was used from creep speed to a maximum of approximately 30 mph.

Data from Spans 4 and 5 show that the maximum amplitude of bridge vibration while the truck was on the span or had passed off the span occurred with a truck speed of approximately 29 mph. This speed represents a time period between axles of 0.33 seconds while the natural period of vibration for these spans is approximately one-half of that, or 0.18 seconds.

A study of the vibration data gathered from the passage of commercial trucks over the bridge spans shows that, in general, a pair of tandem axles, especially when these are the last axles, appeared to reduce the amplitude and duration of free vibration. The effect of a pair of tandem axles on a vehicle such as a 2S2-2 truck which is followed by two single axles does not appear to be as instrumental in reducing the amplitude and duration of free vibration.

Gross Truck Load: Another factor which has been analyzed for its effect on bridge vibration is the total load of the truck. It would have been desirable in the testing procedure to use a given truck and vary the load on this truck while holding other variables, such as truck speed, constant. It was not possible to do this, however, for facilities were not available at the bridge site to change the load. During the normal load tests, the total loads of the trucks varied from 5.3 to 75.3 kips but these vehicles also varied in axle spacing and speed. Thus, the effect of total load

appears to be masked by the influence of other variables. The two trucks causing the most significant vibrations on Spans 1, 2 and 3 had total loads of only 19.5 and 18.5 kips while the largest total load of any truck tested on these spans was 75.3 kips. For four of the five simple spans, trucks with total loads of less than 30 kips caused the most effect on the amplitude of free vibration and the duration of vibration.

Induced Impact: The effect of induced impact, caused by trucks running over boards placed on the span, was studied under controlled loading tests with two-axle and three-axle trucks. The effect of placing a single 3/4-inch board near the center of the span caused an average increase in maximum amplitude of bridge vibration, while the two-axle truck was on the span, of 27 percent; and for a 1-5/8-inch board, 99 percent. The maximum recorded amplitude of bridge vibration for any span (0.086 inch) occurred on Span 5 with the three-axle truck running over a 1-5/8-inch board at a speed of 12.4 mph. This maximum amplitude of vibration was 3.3 times larger than the same maximum for this truck on Span 5 without simulated impact.

The influence of induced impact can also be illustrated by comparing the effect of the three-axle truck on the vibration of Span 5, without boards and with 3/4 and 1-5/8-inch boards and at approximately the same speed in each case. Table 5 makes this comparison and also shows the maximum effective axle load change recorded on the second axle of the truck as it passed over Span 5. Figure 16 is a copy of the three oscillograph traces of the test runs which are compared in Table 5, while Figure 17 shows the changes in effective axle load for the second axle on the same three test runs over Span 5. The effective axle load change was obtained by recording changes in bending strain on the axle by means of electrical strain gages.

TABLE 5

Effect of Induced Impact as caused by a truck running over a board.
(Three-axle test truck). Span 5.

| Test Condition | Truck Speed Ft./Sec. | Max. Amplitude of Vibration - Inches | | Duration of Vibration Seconds | Change in Effective Axle Load Pounds |
|------------------------------------|----------------------------|---|----------------------|-------------------------------------|---|
| | | Truck on Span | Truck off Span | | |
| No Induced Impact | 15.5 | 0.008 | 0.002 | 8.1 | +1300 |
| Induced Impact 3/4-inch Board | 17.2 | 0.034 | 0.0025 | 10.3 | +3800 |
| Induced Impact 1-5/8-inch Board | 16.9 | 0.081 | 0.005 | 16.4 | +6200 |

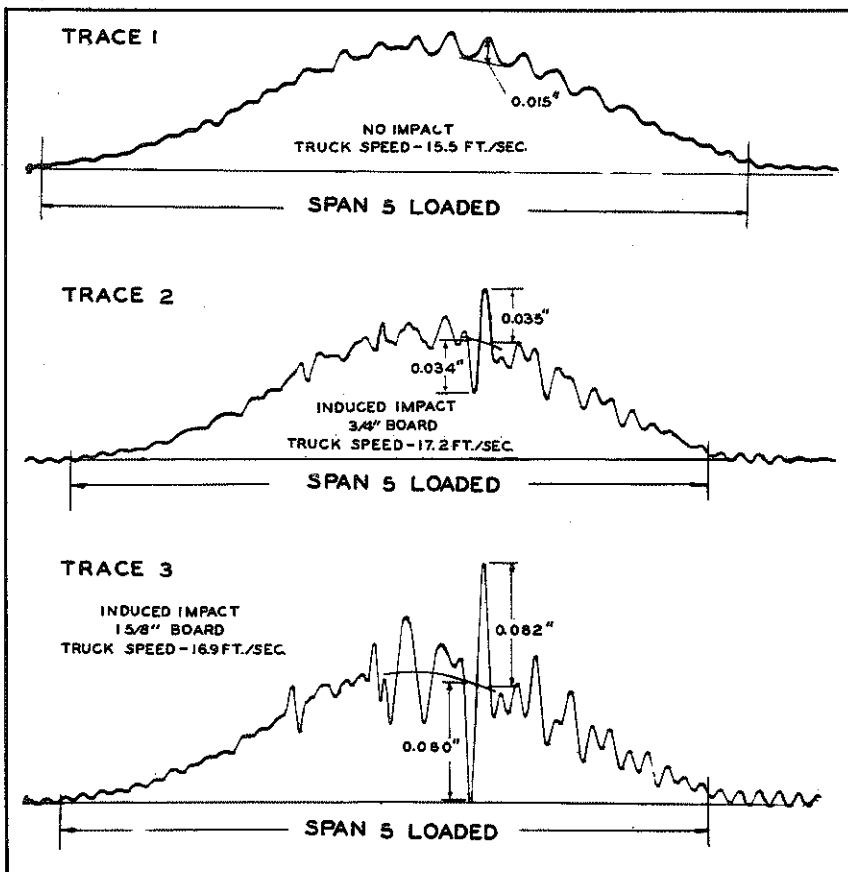

▲ FIGURE 16-OSCILLOGRAPH TRACES SHOWING THE EFFECT OF BOARDS PLACED ON SPAN 5 TO CAUSE IMPACT (THREE-AXLE TRUCK)

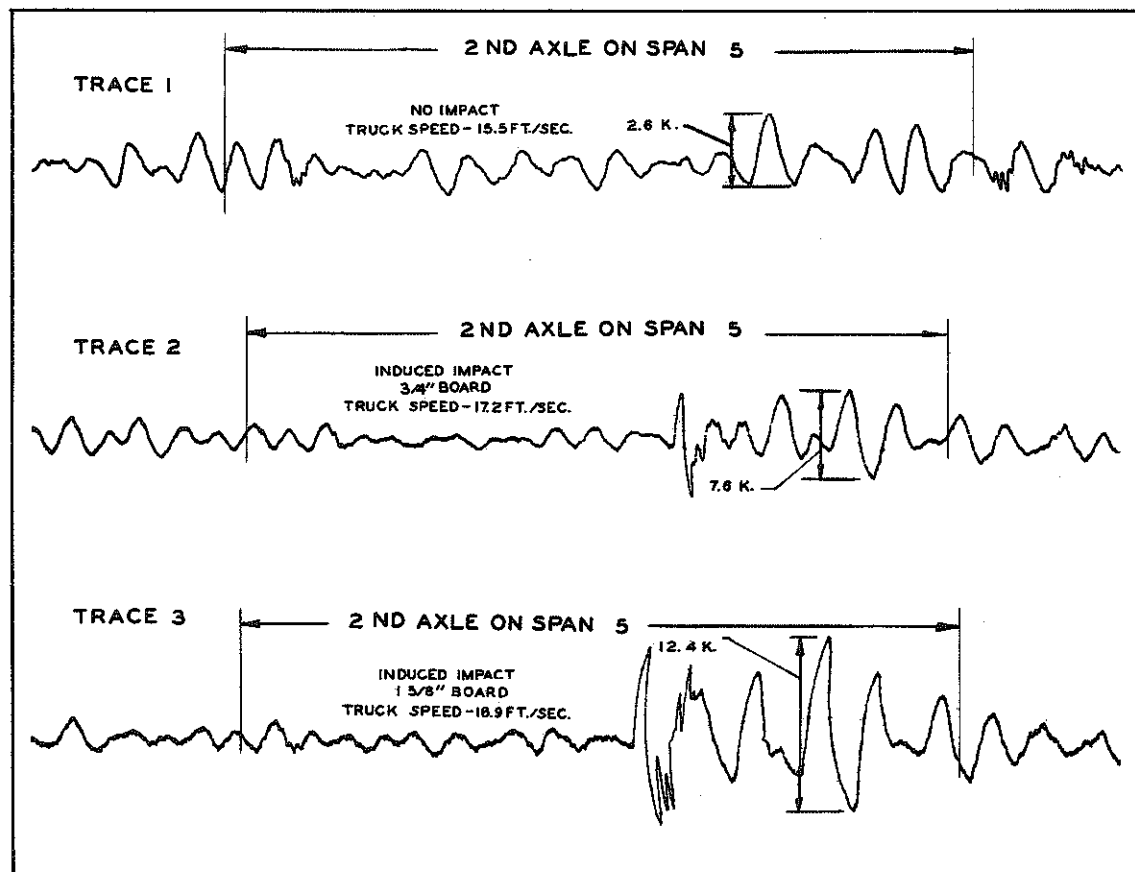

▲ NOTE: ALL THREE TRACES ARE NOT TO THE SAME SCALE
 FIGURE 17-BRUSH OSCILLOGRAPH TRACES SHOWING THE VARIATION IN EFFECTIVE AXLE LOAD WITH AND WITHOUT IMPACT (THREE-AXLE TRUCK)

FIGURE 18- OSCILLOGRAPH TRACE SHOWING VIBRATION AND DEFLECTION OF SPANS 1 THROUGH 4 AS A RESULT OF THREE 2-AXLE TRUCKS PASSING OVER THE BRIDGE IN SEQUENCE.

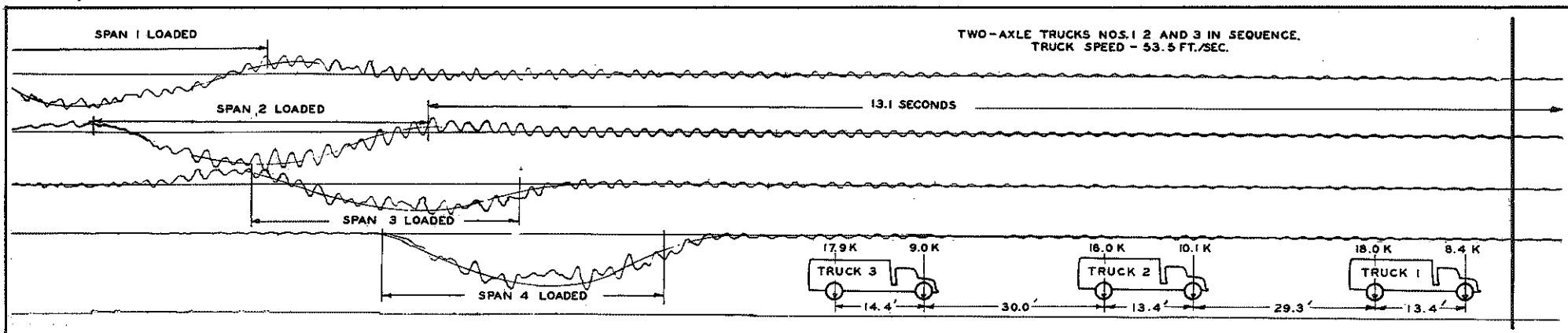

Prior to testing, this change in bending strain was calibrated with effective axle load change. The maximum change in effective load was + 8,900 pounds and occurred as the second axle of the truck struck a 1-5/8-inch board placed near the center of Span 7 while traveling at 17.2 mph. The maximum change without induced impact was + 4,260 pounds and occurred on Span 5 with a truck speed of 31 mph.

Other Factors: Three test runs were made on Spans 1 through 4, and three on Spans 5 through 8, using 3 two-axle trucks in sequence with the distance between the rear axle of the first truck and the front axle of the next truck approximately twice the average axle spacing apart. An oscillograph trace of one of these test runs is shown in Figure 18. It was not possible to obtain maximum speed under these conditions but these test runs do have significance. Although they represent less than 15 percent of the test runs without the effect of impact, they provide the maximum duration of vibration using two-axle county trucks for six of the eight spans and the maximum amplitude of vibration (span loaded condition) for five of the eight spans. Test runs with 2 two-axle trucks passing over the span while traveling side by side also increased the amplitude of vibration to a somewhat lesser degree.

For the three-span continuous structure test runs were also made with sufficient spacing between trucks so that Truck No. 1 would be at the center of Span 3 at the same time that the following truck passed the center of Span 1. This spacing did enhance vibration of the continuous spans and these test runs provided the maximum amplitude of vibration with two-axle test trucks for Spans 1 and 3 under both the span-loaded and span-unloaded conditions.

Discussion of Results

From the preceding data, the following conclusions should be emphasized as points of major importance:

1. The actual deflections of all spans were much less than the calculated deflections - generally about 40 percent of the calculated values.
2. Good correlation existed between the observed deflections of the simple spans and the two present design criteria, "Depth to Span Length Ratio" and "Design Live Load Plus Impact Deflection".
3. In general, the observed amplitude of vibration and duration of vibration increased with span flexibility, as might be expected.
4. The relatively simple method of calculating the natural frequency of vibration of a bridge span, previously proposed, gave excellent agreement with experimental data for the simple spans.
5. The amplitude of vibration and duration of vibration of a bridge span tended to increase when the time interval between axles passing a given point on the span very nearly coincided with the natural period of vibration of the span.
6. Several of the bridge spans, especially Spans 2, 4, and 5, although designed for a "Ratio of Live Load Plus Impact Deflection to Span Length" of 1 to 1000 or more, showed appreciable vibration. Even though the amplitude of vibration was actually quite small, it was very perceptible to a pedestrian on the bridge and may even become disconcerting.
7. A comparison of the center span of the continuous structure with the most flexible simple spans shows that the deflection and amplitude

of vibration (span loaded) was less for the continuous structure, but the amplitude of vibration (span unloaded) and the duration of vibration was greater, and the damping coefficient of vibration was much less for the continuous structure.

PART III. FENNVILLE BRIDGE

Description of Bridge Spans

This structure is composed of six simple spans of rolled beam concrete deck construction with a nominal span length of 60 feet. Seven lines of 36-inch wide flange beams are spaced 5 ft. 2-1/4 in. on centers. The deck is of reinforced concrete construction with a variable slab thickness to provide the required crown at the center and to allow for dead load deflection of the beams. Fundamental information on this bridge is given in Figure 19. Singular features of the various spans are listed as follows:

Span 1 - West end of beams embedded in concrete backwall; two rows of diaphragms double-bolted to beams. Span length, center to center of bearings, is 58 ft. 5 in.

Span 2 - Three rows of diaphragms double-bolted. Span length is 59 ft. 3 in.

Span 3 - Composite construction, using spiral shear developers; two rows of diaphragms single-bolted. Span length is 59 ft. 3 in.

Span 4 - Three rows of diaphragms single-bolted. Span length is 59 ft. 3 in.

Span 5 - Two rows of diaphragms double-bolted. Span length is 59 ft. 3 in.

Span 6 - Two rows of diaphragms single-bolted. The east end of the beams are embedded in the backwall. Span length is 58 ft. 5 in.

A general view of the bridge is shown in Figure 20. Since this bridge is located on a lightly traveled road and truck traffic is rather infrequent, it was considered feasible to test the bridge only under controlled loading conditions, using

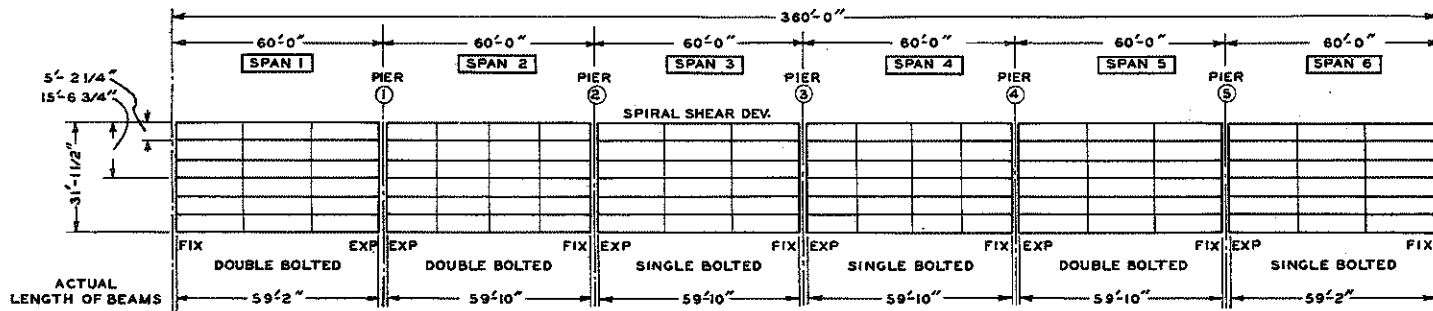

NOTE:
INTERMEDIATE DIAPHRAGMS:
SPANS 1,3,5,6 AT 1/3 POINT
SPANS 2 & 4 AT 1/4 POINT

PLAN

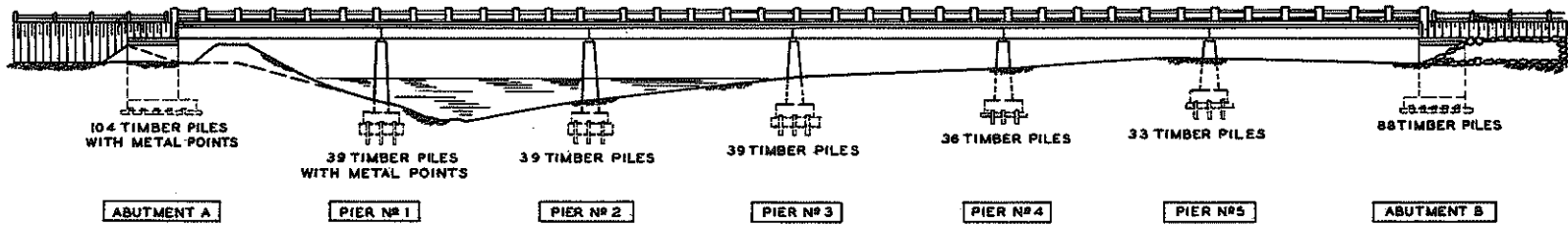

NOTE:
ALL BEAMS 36'WF@182"

ELEVATION

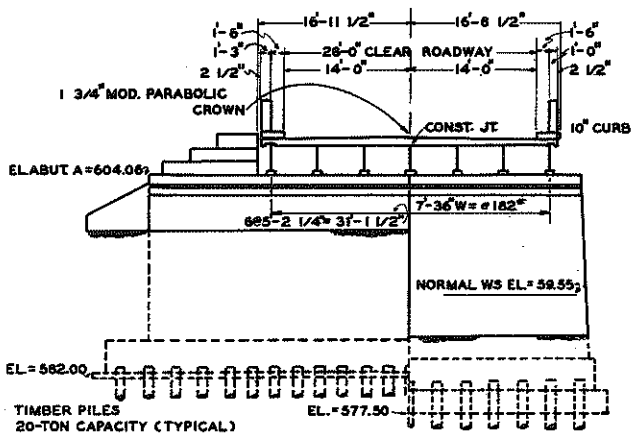

CROSS SECTION AT ABUTMENT

FIGURE 19

GENERAL PLAN OF STRUCTURE
FENNVILLE BRIDGE (BIOF3-9-12)



▲ FIGURE 20- GENERAL VIEW OF FENNVILLE BRIDGE.



▲ FIGURE 21- DEFLECTOMETER INSTALLATION, SPAN 4.

▲ FIGURE 22- LOADING DIAGRAM OF THREE COUNTY MAINTENANCE TRUCKS USED FOR CONTROLLED LOADING TESTS ON FENNVILLE BRIDGE.

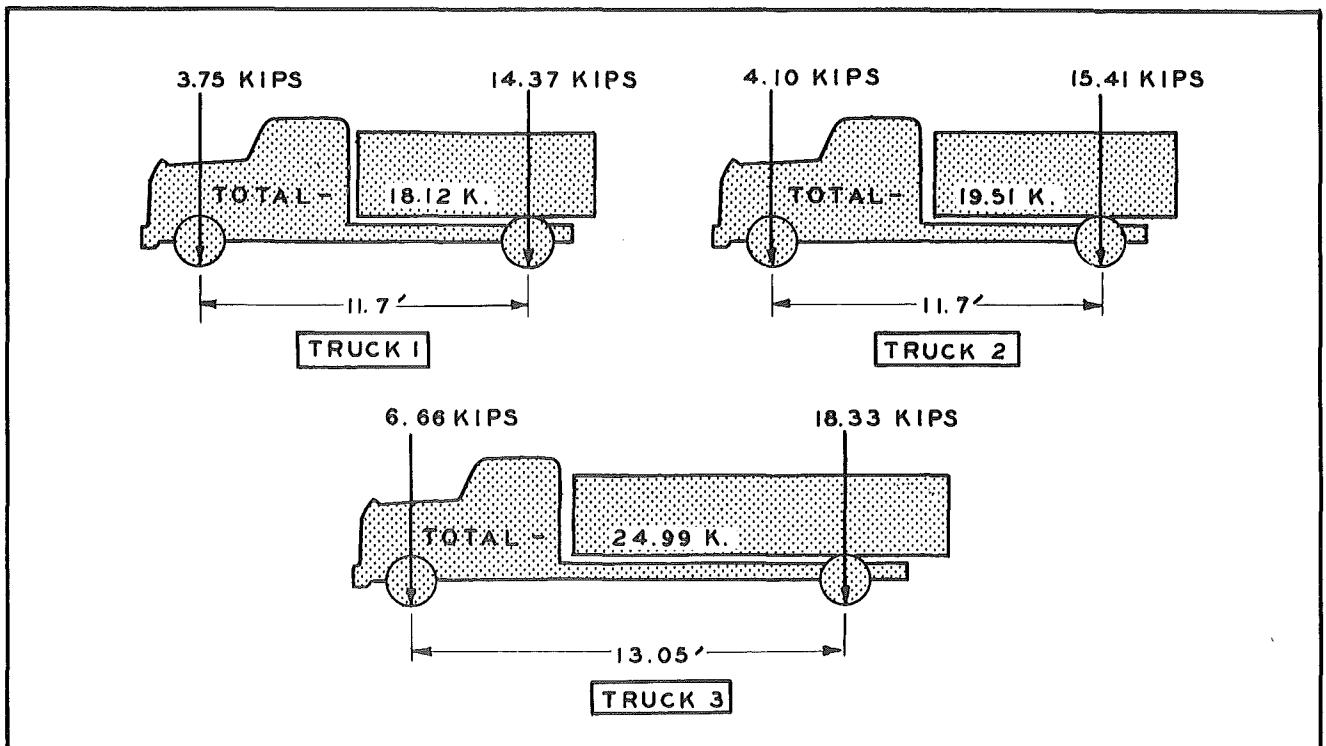

county maintenance trucks and the special three-axle test truck used for previously published tests⁽²⁾ on this bridge.

Test Instrumentation

The same deflectometers were used for this bridge but the devices for fastening to the curb were removed and, instead, the deflectometers were fastened directly to the lower flange of the rolled beams (See Figure 21). This was readily possible here inasmuch as the lower flanges of the beams were approximately 6 to 10 feet above the ground or water while, on the Jackson Bridge, the beams were 22 to 38 feet above the ground or water, and extensive scaffolding would have been necessary. The deflectometers were ordinarily placed on only the center beams of the seven longitudinal beams and at the center of the span. However, on Spans 1 and 4, deflectometers were placed on three to six of the other beams across the span in order to determine the lateral distribution of deflections and vibrations. Except for the above mentioned variations, the instrumentation was similar to that described for the Jackson By-Pass Bridge.

Test Procedure

Controlled Loading, Two-Axle Trucks: In the controlled loading tests on the Fennville Bridge, using county maintenance trucks, the testing program was similar to that of the Jackson Bridge. Figure 22 gives the loading diagrams for these trucks. The variation in axle spacing was 11.7 to 13.05 feet and in gross weight, 18.12 to 24.99 kips. All test runs were made with the trucks straddling the longitudinal centerline of the bridge. Since for every span, deflectometers were placed on the center beam, the trucks were directly above the beams for which vibrations and deflections were being obtained. Again on this program the trucks were to be driven at a speed which would make the time interval between the passing of the first

and second axle equal to the natural period of bridge vibration. This time it was possible to approximate this speed on a few of the runs but even then the speed was somewhat less than intended. When the trucks followed one another in a definite sequence, the truck speed was well below the intended speed. Both the 3/4 and 1-5/8-inch impact boards were also used in some of the test runs.

Controlled Loading, Three-Axle Truck: The special three-axle test truck was used under controlled conditions in the Fennville tests in a similar manner to that used on the Jackson By-Pass Bridge. Effective axle load variation of the test truck was obtained simultaneously with bridge deflection and vibration. The axle loads were identical to those used during the testing of the Jackson Bridge (See Figure 7). Three runs were made at creep speed and at approximately 15, 20, 25, and 30 mph. Also, runs were made at approximately 15, 20, 25, and 30 mph. over 3/4 and 1-5/8-inch impact boards on Spans 1, 3, and 4. The test vehicle approaching the 1-5/8-inch impact board is illustrated in Figure 23.

Test Results

Observed Deflections: A summary of the data on deflection, maximum amplitude and maximum duration of vibration is given in Table 6. A study of the deflection values shows an unusual variation between similar spans. The structural design of Spans 1 and 6 is quite similar but Span 6 has a greater deflection than Span 1. Also, Spans 2, 4, and 5 are nearly the same structurally except for the number of diaphragms and the amount of bolting of the diaphragms to the longitudinal beams. Previous tests on this bridge⁽²⁾ in 1950, however, show the same variations between Spans 1 and 6 and between Spans 2, 4, and 5 but to a somewhat lesser degree. It might further be expected that Span 3 would have a smaller deflection value than shown, on the basis of the previous tests. However, a thorough study of the

Table 6. Summary of Observations on Maximum Deflection and Maximum Amplitude and Duration of Vibration

| Data of Spans | Ratio of Depth to Span Length | Design Live Load Plus Impact Deflection in In. | Deflection in Inches | | Max. Amplitude of Vibration in inches. (Without Induced Impact Effect) | | Max. Duration of Vibration in Seconds After Truck is Off the Span |
|--|-------------------------------|--|----------------------|--------------|---|---------------|---|
| | | | 2-Axle Truck No. 3 | 3-Axle Truck | Span Loaded | Span Unloaded | |
| 1. Simple Span 58'-5" in length. (West end of beams embedded in backwall). | 1/19.5 | 1.037 or 1/676 of span | 0.032 | 0.051 | 0.006 | 0.001 | 6.1 |
| 2. Simple Span 59'-3" in length. | 1/19.8 | 1.085 or 1/655 of span | 0.034 | 0.053 | 0.010 | 0.002 | 3.8 |
| 3. Simple Span 59'-3" in length. Designed for composite action. Shear developers used. | 1/19.8 | 0.457 or 1/1556 of span | 0.032 | 0.051 | 0.007 | 0.002 | 5.5 |
| 4. Simple Span 59'-3" in length. | 1/19.8 | 1.085 or 1/655 of span | 0.045 | 0.081 | 0.012 | 0.002 | 3.9 |
| 5. Simple Span 59'-3" in length. | 1/19.8 | 1.085 or 1/655 of span | 0.042 | 0.073 | 0.015 | 0.002 | 6.5 |
| 6. Simple Span 58'-5" in length. (East end of beams embedded in backwall). | 1/19.5 | 1.037 or 1/676 of span | 0.036 | 0.061 | 0.012 | 0.001 | 8.4 |

present test data fails to disclose any valid reason for doubting its accuracy. Also, it should be noted that the relative deflections between the spans for both the two-axle and the three-axle test truck are substantially in agreement.

A comparison of the tests reported here, conducted in 1952 and 1953, with the tests in 1950 indicate some changes in the rank of stiffness for the various spans. The gross loads used were not the same in the three tests, which might explain the slight changes in rank shown in Table 7. This table does show that the stiffness rank was identical for the 1952 and 1953 tests. However, a comparison of the 1950 tests with the 1952-53 tests would elicit the following remarks:

1. The stiffness rank of Span 3 has decreased relative to the other spans.
2. The stiffness rank of Spans 2 and 6 have been reversed.

In the 1950 tests, deflection readings were not taken for the truck straddling the longitudinal centerline of the bridge for all six spans. However, comparing the spans where readings were obtained gives the data shown in Table 8. This comparison indicates that the deflection value per kip is very similar for the two tests for Spans 3 and 4, but the 1953 test values are smaller than the 1950 values for Spans 5 and 6, indicating a less flexible condition for these spans on the later tests.

Observed Deflections Compared to Theoretical Deflections: In Table 9, the actual deflections are compared to the calculated or theoretical deflection for the three-axle test truck. The theoretical deflection neglects the stiffening effect of the concrete deck which is common practice in design when composite construction is not used. For Span 3, with composite construction, the calculated deflection is based on an effective T-beam cross-section which includes the rolled beam and a 5 ft. 2-1/4-in. width of concrete deck above the beam. The ratio of the modulus

TABLE 7

Comparison in Rank of Stiffness of the Six Fennville Bridge Spans on the Basis of 1950 and 1952-53 Tests.

| | <u>Rank of Stiffness Based on Deflection</u> | | |
|--------|--|--------------|---------------|
| | 1950 Tests* | 1952 Tests** | 1953 Tests*** |
| Span 1 | 2 | 1.5 | 1.5 |
| Span 2 | 4 | 3 | 3 |
| Span 3 | 1 | 1.5 | 1.5 |
| Span 4 | 6 | 6 | 6 |
| Span 5 | 5 | 5 | 5 |
| Span 6 | 3 | 4 | 4 |

* Tests performed with special 3-axle truck with gross weight of 72 kips, reported in "Tests in Rolled-Beam Bridge Using H 20-S16 Loading", G. M. Foster, Highway Research Board, Research Report 14-B.

** Tests using 2-axle truck with a gross weight of 25 kips.

*** Tests using special 3-axle truck with a gross weight of 50 kips.

TABLE 8

Comparison of the Observed Deflections of the Center Beam for Various Fennville Bridge Spans on the Basis of 1950 and 1953 Tests.

(Three-axle test truck)

| Span | 1950 Tests | | | 1953 Tests | | |
|------|------------|-------------------|---------------------|------------|-------------------|---------------------|
| | Load-Kips | Deflection Inches | Deflection Inch/Kip | Load-Kips | Deflection Inches | Deflection Inch/Kip |
| 3 | 72 | 0.079 | 0.0011 | 50 | 0.051 | 0.0010 |
| 4 | 72 | 0.116 | 0.0016 | 50 | 0.081 | 0.0016 |
| 5 | 72 | 0.126 | 0.0017 | 50 | 0.073 | 0.0015 |
| 6 | 72 | 0.120 | 0.0018 | 50 | 0.061 | 0.0012 |

TABLE 9

Comparison of Actual to Theoretical Deflection of Fennville Bridge Spans
(Special three-axle test truck).

| Span | Actual Deflection Inches | Theoretical Deflection Inches | Ratio Actual / Theoretical |
|------|--------------------------------|-------------------------------------|----------------------------------|
| 1 | 0.051 | 0.447 | 0.11 |
| 2 | 0.053 | 0.476 | 0.11 |
| 3 | 0.051 | 0.181 | 0.28 |
| 4 | 0.081 | 0.476 | 0.17 |
| 5 | 0.073 | 0.476 | 0.15 |
| 6 | 0.061 | 0.447 | 0.14 |

of elasticity of steel to concrete is considered as 6. The amount of the lane load considered as acting on one longitudinal beam is calculated on the basis of the distribution of wheel load to an interior longitudinal beam, as specified for design in the Standard Specifications for Highway Bridges as adopted by the AASHO. The smallest ratio of actual to calculated deflection was 0.11 (Span 1) while the largest ratio was 0.28 (Span 3).

Maximum Amplitude of Vibration: Due to the stiffer nature of the spans on the Fennville Bridge, it was much more difficult to instigate vibrations. These vibrations, when initiated, were not as great in amplitude and were much shorter in duration than on the Jackson Bridge. In addition, since this bridge is located in a rather isolated area and truck traffic is very light, it was not feasible to attempt to use commercial trucks for this study. This limited the type of trucks, the axle spacings, and the range in gross weight of the trucks to those which might economically be obtained for load testing. Perhaps the most stringent limitation was the number of axles, for it is believed that greater amplitude and duration of vibration might be obtained with trucks having a greater number of axles.

The maximum amplitude of vibration without induced impact was 0.015 inch (See Table 6) which occurred on Span 5 with the three-axle truck on the span traveling at a speed of 24.5 mph. The maximum amplitude of vibration (span unloaded) was 0.002 inch which occurred on Spans 2, 3, 4, and 5. The amplitudes of vibration with span unloaded were so small for all spans that the difference between spans is not significant.

Maximum Duration of Vibration: The maximum duration of vibration occurred on Span 6 due to the three-axle truck passing over an impact board on Span 4. The reason for the effect of impact on one span influencing the behavior of another span is not known at this time but its effect was definitely transmitted by some means -

perhaps through the deck or the bridge piers. All spans appeared to be susceptible to the influence of impact on nearby spans. Figure 25 illustrates the vibration that takes place. Impact boards were placed on Spans 1 and 3. As the truck struck a 1-5/8-inch board on Span 3, Spans 1 and 2 began to vibrate even though the truck had not yet reached these spans. This vibration then died out on Span 1 by the time the truck had reached the center of Span 2. As the truck struck the 1-5/8-inch board on Span 1, Span 3, which had ceased to vibrate, began another series of vibrations.

Observed Frequency of Vibration: As a result of the stiffer nature of the Fennville Bridge spans and due to the fact that the truck types used for testing were limited, the occurrence of vibrations was much less frequent than on the Jackson Bridge. Sufficient cases of vibration occurred to establish the natural frequency of the bridge spans as given in Table 10, but these values are not as accurate as those obtained from the Jackson Bridge. It should be noted that two values are given in most cases for the Average Frequency of Significant Vibrations. The second value is always approximately twice that of the first value. These bridge spans vibrated at either frequency and, in some cases, for a given test run they first vibrated at one frequency and later at the other. An oscillograph trace illustrating vibrations at both frequencies is shown in Figure 26. Since it was possible to work beneath the bridge, deflectometers were placed on all longitudinal beams on Spans 1 and 4. These data on the lateral distribution of the deflection and vibration sheds some light on the nature of these two frequencies of vibration. In every case where the span was vibrating at its natural frequency (approximately 7 cycles per second) all of the longitudinal beams in the span were vibrating in phase. However, in every case where the span was vibrating at approximately

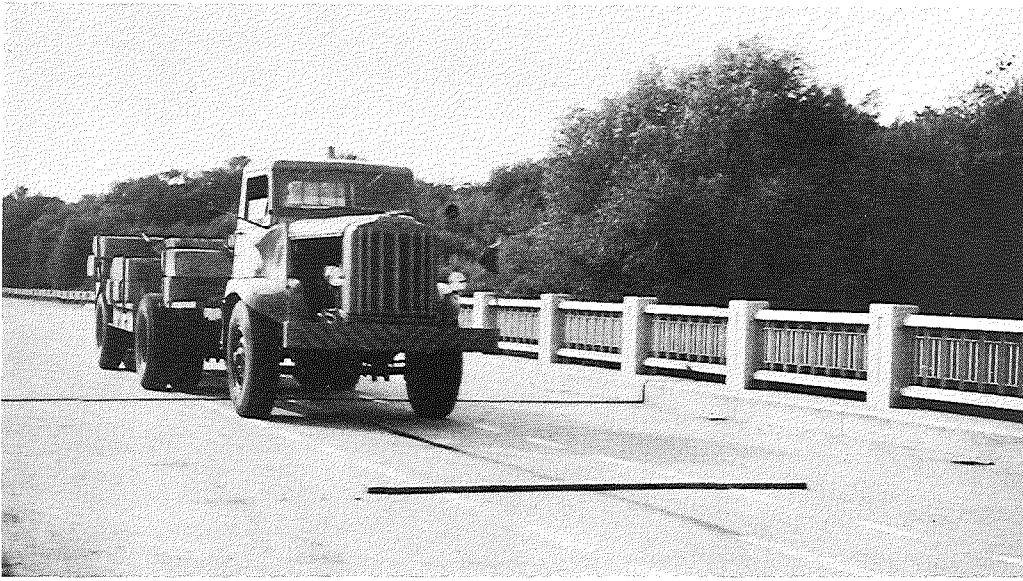

FIGURE 23- THREE-AXLE TEST TRUCK APPROACHING A 1 5/8-INCH BOARD PLACED ON THE SPAN TO CAUSE IMPACT.

FIGURE 25- OSCILLOGRAPH TRACE ILLUSTRATING THE INFLUENCE OF IMPACT EFFECTS ON ONE SPAN BEING TRANSMITTED TO ADJACENT SPANS.

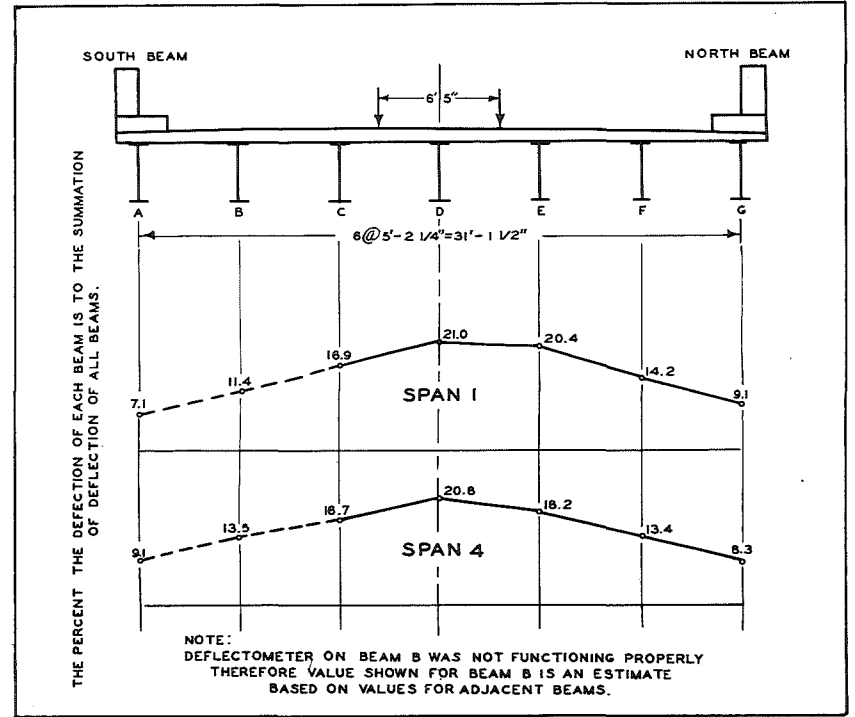
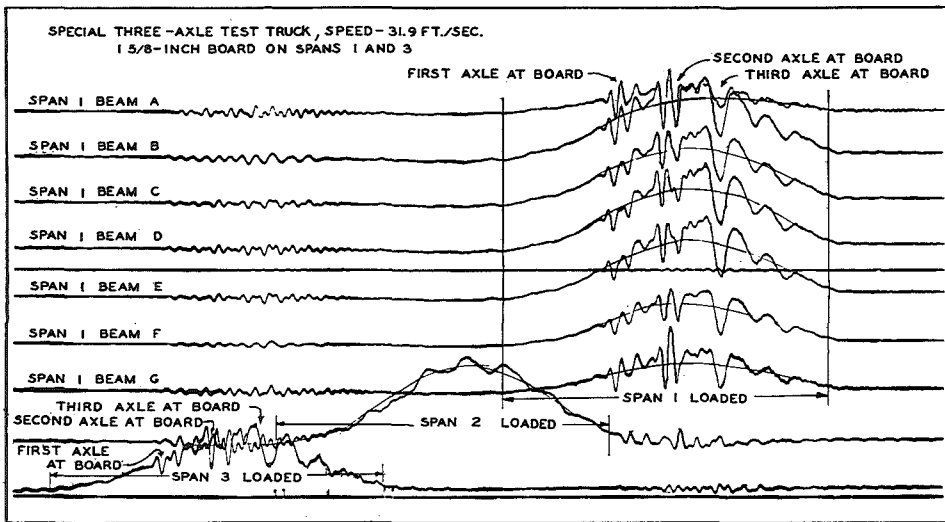

FIGURE 24- LATERAL DISTRIBUTION OF DEFLECTION (THREE-AXLE TEST TRUCK)

FIGURE 26- OSCILLOGRAPH TRACE ILLUSTRATING THE VIBRATION OF SPAN 4 AT TWO FREQUENCIES.

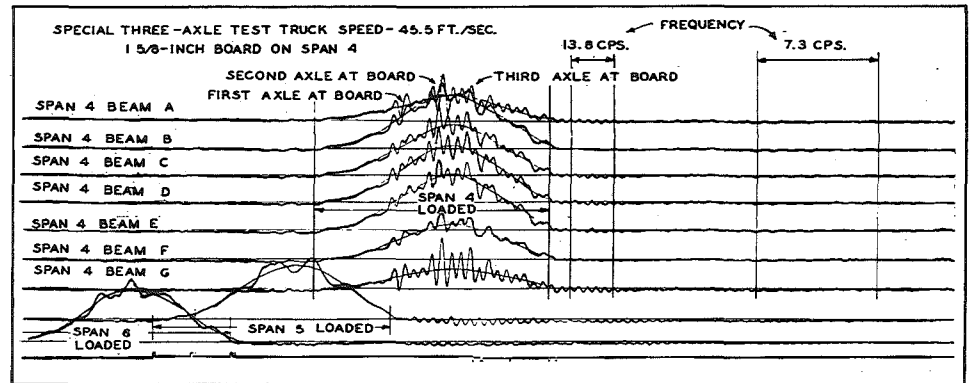

Table 10. Summary of Observations on Frequency of Vibration

| Data on Spans | Ratio of Depth to Span Length | Design Live Load Plus Impact Deflection in Inches | Average Frequency of Significant Vibrations in Cycles / Second * | | | Theoretical Natural Frequency of Vibration in Cycles/Second . | % Difference of Theoretical to Actual Frequency Observed |
|--|-------------------------------|---|--|--------------|--------------|---|--|
| | | | 2-Axle Trucks | 3-Axle Truck | Average | | |
| 1. Simple Span - 58'-5" in length. (West end of beams embedded in backwall). | 1/19.5 | 1.037 or 1/676 of span | 7.1 | 7.1 and 15.0 | 7.1 and 15.0 | 6.9 | 2.8 |
| 2. Simple Span - 59'-3" in length. | 1/19.8 | 1.085 or 1/655 of span | 6.9 | 7.1 and 14.6 | 7.0 and 14.6 | 6.7 | 4.3 |
| 3. Simple Span -59'-3" in length. Designed for composite action - shear developers used. | 1/19.8 | 0.457 or 1/1556 of span | 7.0 | 6.9 and 14.9 | 7.0 and 14.9 | 7.2 | 2.9 |
| 4. Simple Span - 59'-3" in length | 1/19.8 | 1.085 or 1/655 of span | 6.9 and 14.2 | 6.9 and 14.0 | 6.9 and 14.1 | 6.7 | 2.9 |
| 5. Simple Span - 59'-3" in length. | 1/19.8 | 1.085 or 1/655 of span | 6.8 and 14.1 | 6.9 and 13.9 | 6.9 and 14.0 | 6.7 | 2.9 |
| 6. Simple Span - 58' -5" in length. (East end of beams embedded in backwall.) | 1/19.5 | 1.037 or 1/676 of span | 7.3 and 14.4 | 7.2 and 14.3 | 7.2 and 14.3 | 6.9 | 4.2 |

NOTE: * - The average of test runs where at least 5 cycles of continuous vibration occurred after the truck had passed over the span.

14 cycles per second, the outside beams were vibrating 180 degrees out of phase with the center beam. Although these observations were made on only Spans 1 and 4, it is reasonable to expect that the same thing occurred on the other spans when they vibrated at these two frequencies.

Calculated Natural Frequency of Vibration: Theoretical calculations to obtain the natural frequency of vibration were made in a similar manner to those for the Jackson Bridge. Since the test trucks straddled the longitudinal centerline of the bridge, the center longitudinal beam and a width of concrete deck equal to the spacing between beams was considered in the computations. As before, when the spans were not designed for composite action, the concrete deck was estimated to be only 50 percent effective. For the span designed for composite action (Span 3) the concrete deck was estimated to be 100 percent efficient in stiffening the structure. The calculated frequency was slightly less than the observed frequency for all spans except Span 3, indicating a stiffer structural condition than calculated. The average difference between calculated and observed frequency without regard to direction was 3.3 percent for these spans, while for the simple spans on the Jackson Bridge, this difference was only 1.2 percent.

In the previous tests on this bridge conducted in 1950, vibrations occurred only while the truck was on the span. One reason for this was the limiting speed of 12 mph. due to the fact that the west bridge approach was not complete. The frequency of the vibrations varied from 2.12 to 2.85 cps. These frequencies were not close to the natural frequencies of the bridge spans. Recent tests indicate that the frequency of vibration with the span unloaded is much more uniform and generally very close to the natural frequency of vibration of the structure.

Damping of Free Vibration: The damping coefficients given in Table 11 may be considered only approximate, since the amplitude of vibration after the truck had passed off the span was very small and, often, vibration would decrease and then increase again in magnitude in a recurring pattern. The damping coefficients for the spans of this rolled beam structure are definitely greater than for the spans of the plate girder bridge.

Factors Influencing Vibration

Type of Truck, Axle Spacing, and Truck Speed: It was not possible to establish the influence on vibration of some of the variables discussed previously on the other bridge. Here, the types of trucks for load testing were limited to the 2-D and the 2S1. Thus, insufficient data was available to determine the effect of the type of vehicle on bridge vibration. In the case of the two-axle county maintenance trucks, a speed was attained in a few test runs where the time interval between the first and second axle passing a given point was only slightly more than the natural period of vibration for the spans. However, even though greater speeds were obtained with the two-axle trucks, the maximum amplitude of vibration was, in every case, obtained with the slower three-axle truck. The maximum amplitudes for each span obtained with the two-axle trucks averaged only 36 percent of those obtained with the three-axle truck. It is true that the three-axle truck was slightly more than twice as heavy as the two-axle trucks but it appears from the previous data that the number of axles was more influential in causing the increased amplitude of vibration than was the weight of the truck.

Three test runs with the three-axle truck were made at creep speed and at approximately 15, 20, 25, and 30 mph. without impact effects. The maximum amplitude of vibration for the 6 spans occurred for 2 spans at approximately

TABLE 11

Damping Coefficients of Vibration
 - Fenville Bridge

| Span | Type | Damping Coefficient |
|------|--|---------------------|
| 1 | Simple Span - rolled beam | 0.029 |
| 2 | Simple Span - rolled beam | 0.040 |
| 3 | Simple Span - rolled beam with composite design with deck. | 0.057 |
| 4 | Simple Span - rolled beam | 0.015 |
| 5 | Simple Span - rolled beam | 0.015 |
| 6 | Simple Span - rolled beam | 0.024 |

30 mph. for 3 spans at 25 mph. and for 1 span at approximately 15 mph. However, the maximum duration of vibration for all 6 spans occurred at a speed of approximately 30 mph. A truck speed of 67 mph. would have given a time interval between the passage of the first and second, and second and third axles equal to the average natural period of vibration of the 6 spans.

The test runs where two trucks passed over the bridge spans in a definite sequence tended to increase the amplitude of vibration while the span was loaded. To a lesser extent, the amplitude of vibration was also increased by two trucks passing over the bridge side by side.

Induced Impact: Impact effects produced by the truck running over boards placed on the span had a marked effect in increasing the amplitude of vibration. The maximum amplitudes obtained were 0.048 and 0.006 inches for the span-loaded and span-unloaded conditions. These occurred with the three-axle truck passing over a 1-5/8-inch board at 20.2 and 21.8 mph., respectively. The influence of this induced impact is quite apparent in Table 12 where the maximum amplitudes are compared with and without impact for the three spans where impact effects were studied.

Another method of studying the effect of impact is shown in Table 13 which presents the data from 12 test runs with the three-axle truck. This data compares the results of four runs each with no board, 3/4-inch board, and 1-5/8-inch board at almost identical speeds for the three test conditions. Such a comparison indicates that the average amplitude of vibration is increased 13 percent for the 3/4-inch board and 247 percent for the 1-5/8-inch board while the increased variation in effective axle load was 78 and 279 percent, respectively.

TABLE 12

The Influence of Induced Impact on the Maximum Amplitude of Vibration
(Special 3-axle test truck)

| Span | Maximum Amplitude of Vibration - Inches | | | Percent Increase | |
|---------|---|----------------|--------------|------------------|--------------|
| | No Impact | Impact Due to: | | 3/4" Board | 1-5/8" Board |
| | | 3/4" Board | 1-5/8" Board | | |
| 1 | 0.0065 | 0.0095 | 0.0235 | 46 | 260 |
| 3 | 0.007 | 0.012 | 0.0225 | 72 | 220 |
| 4 | 0.012 | 0.013 | 0.048 | 8 | 300 |
| Average | | | | 42 | 260 |

TABLE 13

Effect of Induced Impact as Caused by a Truck Running Over a Board
(3-axle test truck) Span 4.

| Test Condition | Amplitude of Vibration Span Loaded - Inches | | Variation in Effective Axle Load - Pounds - | |
|-------------------------------|---|-----------|---|----------|
| | Range | Average * | Range | Average* |
| No Impact | 0.011 to 0.020 | 0.015 | + 1500 to +2140 | +1920 |
| Impact due to 3/4" Board | 0.010 to 0.021 | 0.017 | + 2030 to +4600 | +3420 |
| Impact due to 1-5/8" Board | 0.024 to 0.096 | 0.052 | +5950 to +9800 | +7270 |
| Percent Increase 3/4" Board | | 13 | | 78 |
| Percent Increase 1-5/8" Board | | 247 | | 279 |

* This is the average of four selected test runs for each test condition at truck speeds of 15-30 mph. where the truck speeds were almost the same for the three conditions of no impact, 3/4" board and 1-5/8" board.

A study of the strains on the second axle of the truck disclosed that the range in frequency of load fluctuation varied from 2.48 to 3.73 cps., and the maximum variation in effective axle load without impact was + 2900 pounds. A comparison between the maximum variation in effective axle load as the truck approached the bridge and while it was on the bridge indicated that the variation was more than twice as great for the latter case.

Lateral Distribution of Deflections

The variation in deflection of the seven longitudinal beams, with the test load directly above the center beam, was obtained on Spans 1 and 4 for both the two-axle and three-axle truck loadings. For the two-axle truck loading, deflections were obtained on four or five of the seven beams while, on the three-axle truck tests, deflectometers were placed on all seven beams. In the latter testing, however, one deflectometer was found to be faulty. The lateral distribution of the beam deflection is shown in Figure 24 on the basis of the average values obtained for all tests with the three-axle truck without impact effects.

In the previous study of the Fennville Bridge, it was found advisable to compare the lateral distribution on the spans by use of an index.

This index is the absolute sum of the deviations of the percent of total deflection or strain for each beam from 14 percent. In other words, the deflection index was formed by (1) summing the recorded deflections for all seven beams under a certain load condition and designating this total as 100 percent; (2) denoting the deflection on each beam as a percent of this total deflection; (3) finding the numerical difference for each beam between the percent of total deflection and 14 percent, since each beam would deflect slightly over 14 percent of the total deflection if the distribution were perfect; and (4) summing those deviations without regard to

sign to form the index. (2)

Table 14 compares these indices for Spans 1 and 4 for the previous tests as well as the tests reported here. The values for the 1952 and 1953 tests indicate a more uniform distribution of the deflection than did the previous tests, for a perfectly uniform distribution would give an index of 0, while no distribution would result in an index of 170.

Discussion of Results

After a study of the test data on the Fennville Bridge, the following points are apparent:

1. This rolled beam structure is much stiffer than assumed in the design. When averaged for the six spans, the observed deflection is only 16 percent of the calculated deflection for a given load.
2. The amplitude of vibration for this bridge is so small that it is barely perceptible to a person on the bridge.
3. All spans of this bridge vibrate at the lowest natural frequency of the spans and at a frequency approximately twice this.
4. The proposed method of calculating the natural frequency of a bridge span gave good agreement with the observed frequency of vibration.
5. The effect of surface irregularities on the span, as simulated by boards placed on the span, caused impact effects which increased the amplitude of vibration. For the thicker board, this increase was very marked.

TABLE 14

Comparison of Indices for Lateral Distribution

| Span | 1950 Tests* | 1952 Tests** | 1953 Tests*** |
|------|-------------|--------------|---------------|
| 1 | 48 | 29 | 31 |
| 4 | 52 | 32 | 26 |

* Tests performed with special 3-axle truck with gross weight of 72 kips, reported in "Tests in Rolled Beam Bridge Using H 20-S16 Loading", G. M. Foster, Highway Research Board, Research Report 14-B.

** Tests using 2-axle trucks.

*** Tests using special 3-axle truck with a gross weight of 50 kips.

PART IV. SUMMARY

Comparison of the Two Bridges

A general comparison may be made of the two bridges on the basis of data obtained by the use of the special three-axle truck, since test conditions were very similar in this case for the two bridges. The average deflection of the spans on the Fennville Bridge was 23 percent less than the average deflection of the simple spans on the Jackson Bridge. However, the average maximum amplitude of vibration on the Fennville Bridge was 48 percent less for the span-loaded condition and 64 percent less for the span-unloaded condition than that of the Jackson Bridge. On the Fennville Bridge, the average for the spans of the maximum duration of vibration was 62 percent less than that of the Jackson Bridge.

It should be noted that the average "Ratio of Depth to Span Length" is 1 to 19.1 for the Jackson Bridge spans and 1 to 19.7 for the Fennville Bridge spans, while the average "Ratio of the Design Live Load Plus Impact Deflection to Span Length" is 1 to 1100 and 1 to 660, respectively, excluding the span with spiral shear developers. Thus, it is apparent that between different types of structures (that is, plate girder to rolled beam bridges), these two ratios are not adequate for controlling the magnitude of bridge vibration.

General Findings

It should be emphasized that the following conclusions are based on tests of only a few bridge spans of each type and further research or more extensive testing may modify some of these concepts.

1. For the plate girder structure, good correlation existed between the observed deflections of the simple spans and the two current bridge design criteria.

2. The amplitude of vibration and the duration of vibration of a bridge span tended to increase when the time interval between axles passing a given point on the span very nearly coincided with the natural period of vibration of the span. Thus, the type of truck and its axle spacing, in conjunction with its speed, does have an effect on bridge vibration.
3. The largest ratio of maximum amplitude of vibration, without induced impact, to maximum deflection for a given span was 0.25 for the plate girder structure and 0.21 for the rolled beam structure.
4. The maximum amplitude of vibration, with induced impact, approached and in some cases exceeded the maximum deflection for a given span.

Findings Pertinent to Design Concepts.

1. In both bridge structures, the spans were much stiffer than assumed in the design. For all spans tested, the observed deflection was always less than one-half of the value based on design calculations. The ratio of observed to calculated deflection was much smaller for the rolled beam structure than it was for the plate girder structure.
2. The amplitude of vibration on the rolled beam bridge was sufficiently small so that it was barely perceptible to a person on the bridge. However, the amplitude of vibration on the plate girder structure was much greater; it was easily perceptible and could be considered disconcerting to a pedestrian on the bridge.
3. The method previously discussed of computing the natural frequency of vibration for non-composite spans on the basis of an effective cross-section, which includes 50 percent of the concrete deck above the beam,

and the beam or plate girder (100 percent of the concrete deck for composite spans), gave an average error of slightly over 2 percent when compared to the observed natural frequency.

4. If the two present design criteria are used as a means of preventing undesirable bridge vibration, then separate limiting values are required for plate girder and rolled beam structures.
5. A better means of controlling undesirable bridge vibration is by limiting the natural frequency of vibration of the bridge span.

(The method previously proposed for computing the natural frequency of vibration is a relatively simple computation and yet possesses sufficient accuracy for design purposes.) On the basis of these tests, it appears that if the natural frequency of the span is limited to a value greater than 6.5 cps., the amplitude of vibration will be sufficiently small to prevent pedestrian discomfort or uneasiness. More flexible structures than this are entirely adequate structurally, but the psychological reaction of pedestrians to more flexible structures may warrant such a limitation in certain cases.

BIBLIOGRAPHY

1. Norman, R. G. , "Vibration of a Highway Bridge", New Zealand Engineering, March 15, 1950, pp. 239-243.
2. Foster, G. M. , Test on Rolled Beam Bridge Using H20-S16 Loading, Highway Research Board, Research Report 14-B, Wash. , D. C. 1952.
3. Hansen, H. M. , and P. F. Chenea, Mechanics of Vibration, New York, 1952, John Wiley & Sons, Inc.
4. Timoshenko, S. , Vibration Problems in Engineering, New York, 1937, D. Van Nostrand Company, Inc.
5. Thomson, W. T. , Mechanical Vibrations, New York, 1948, Prentice-Hall, Inc.