

BEAM TYPE	C (FOR L ≤ 22 FEET)				C (FOR 22 FEET < L ≤ 40 FEET)			
	2 COLUMNS	3 COLUMNS	4 COLUMNS	4 COLUMNS	2 COLUMNS	3 COLUMNS	4 COLUMNS	4 COLUMNS
28" (Type I)	3'-0"	5'-0"	5'-6"	5'-6"	3'-0"	4'-0"	4'-6"	4'-6"
36" (Type II)	5'-6"	6'-6"	6'-6"	7'-0"	4'-6"	4'-6"	6'-0"	6'-0"
45" (Type III)	6'-6"	8'-6"	8'-6"	9'-6"	5'-3"	5'-3"	7'-6"	7'-6"
54" (Type IV)	7'-6"	10'-0"	10'-0"	12'-0"	6'-3"	6'-3"	8'-6"	8'-6"

	DEPARTMENT DIRECTOR Bradley C. Wiefelich, P.E.	MICHIGAN DEPARTMENT OF TRANSPORTATION BRIDGE SIGN CONNECTIONS TYPE C, D & E		
	PREPARED BY ANCILLARY STRUCTURES DRAWN BY: <u>HNTB</u> CHECKED BY: <u>MLD</u>	APPROVED BY: _____ DIRECTOR, BUREAU OF FIELD SERVICES	(SPECIAL DETAIL) F.H.W.A. APPROVAL	08/08/23 PLAN DATE
APPROVED BY: _____ DIRECTOR, BUREAU OF DEVELOPMENT		SHEET 1 OF 11		

NOT TO SCALE		MICHIGAN DEPARTMENT OF TRANSPORTATION		
(SPECIAL DETAIL) F.H.W.A. APPROVAL	08/08/23 PLAN DATE	SIGN-810-B	SHEET 2 OF 11	

NOTE:
HORIZONTAL BRACES ARE
NEEDED FOR SKEW'S FROM
0° - 40° WITH 2 THRU 4
COLUMNS.

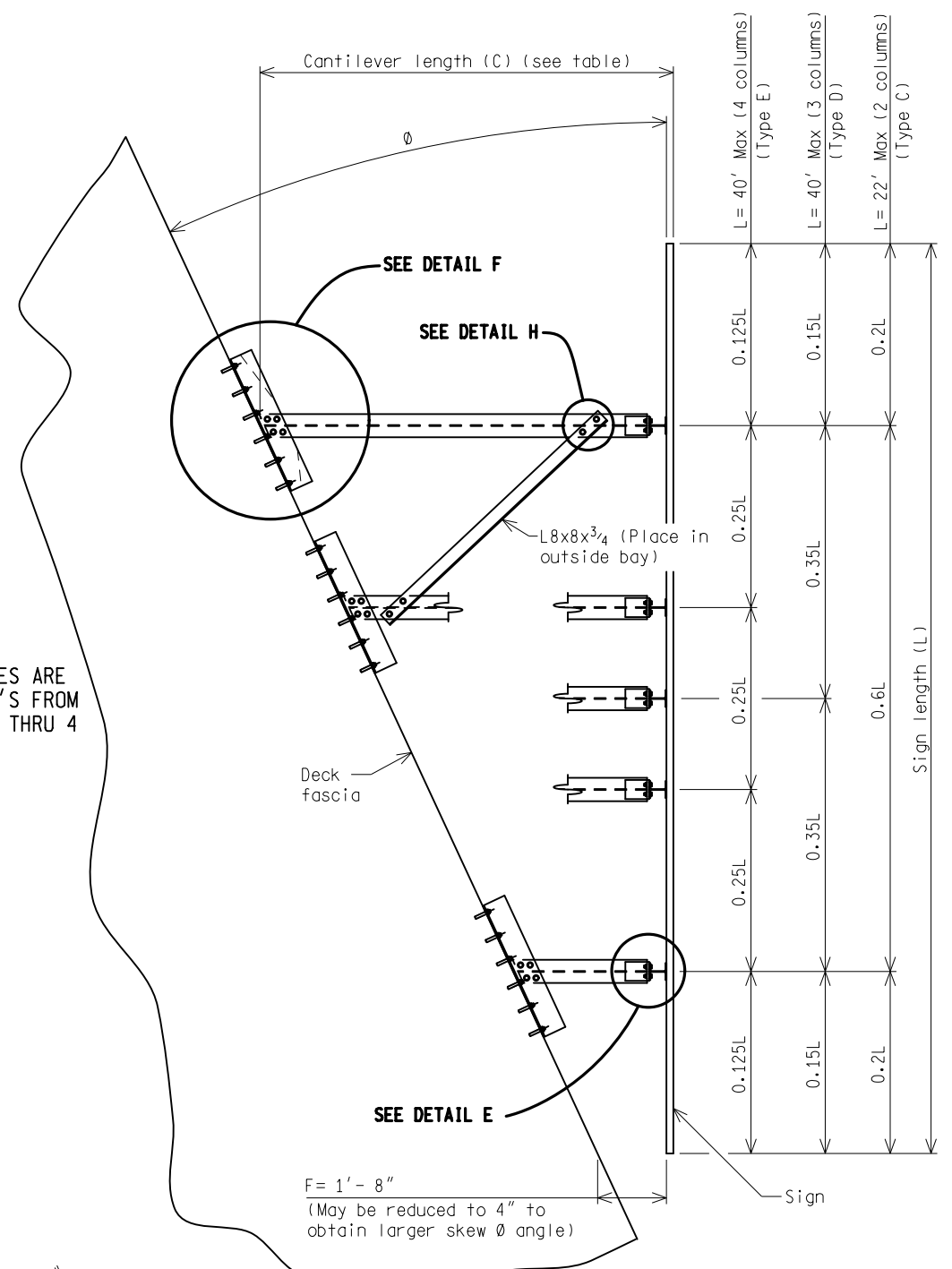

PLAN VIEW (TOP CHORDS)

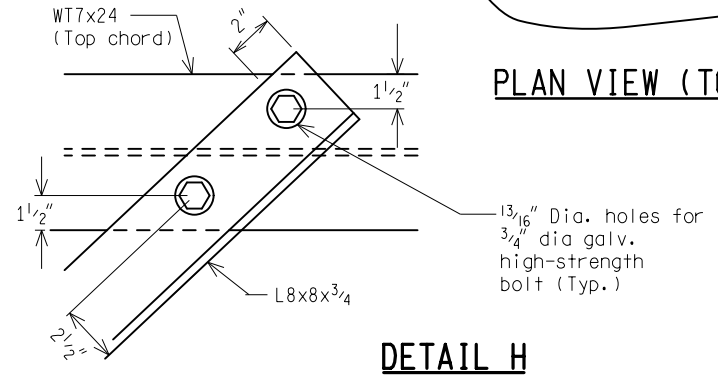

DETAIL H

NOT TO SCALE

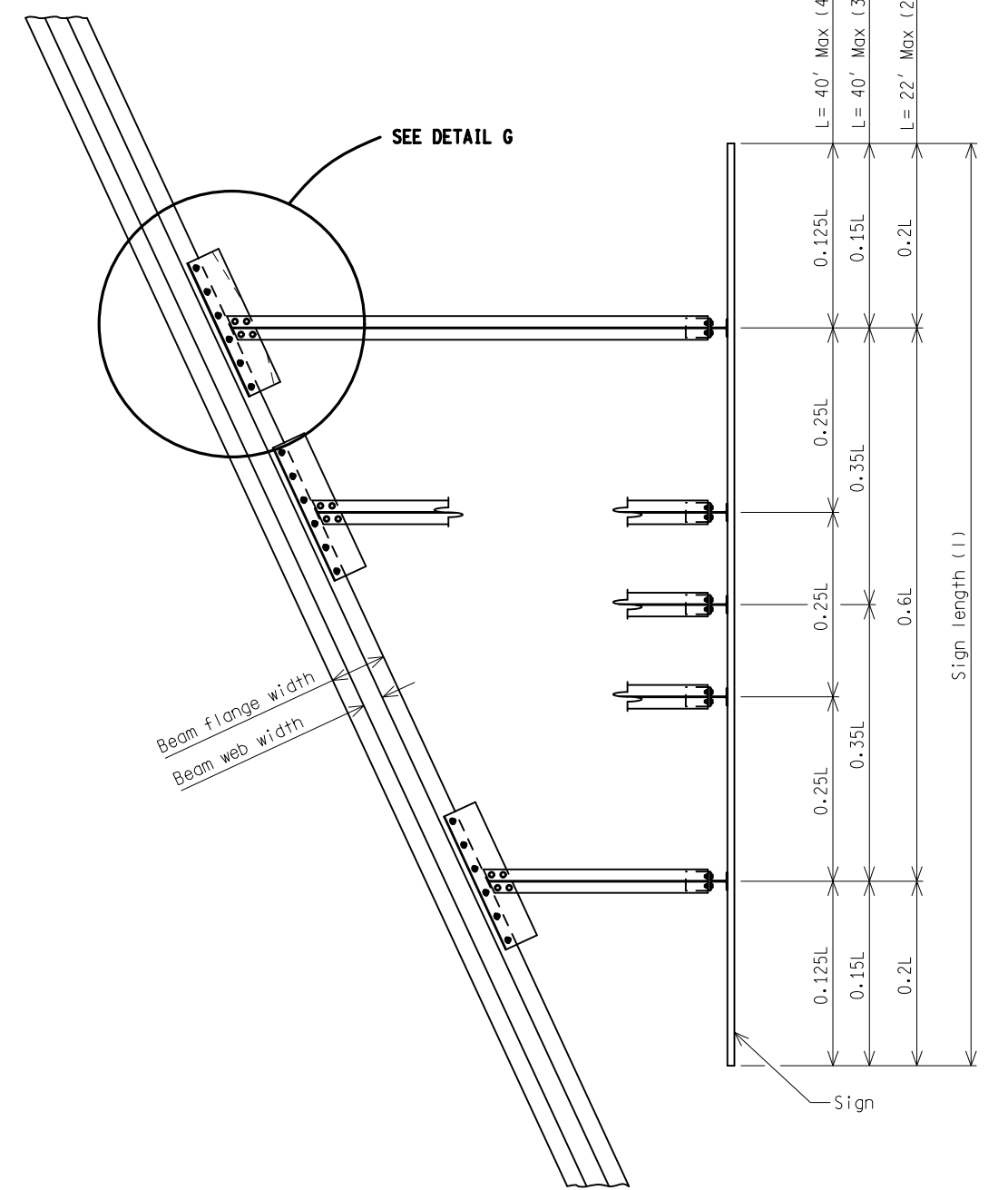

PLAN VIEW (BOTTOM CHORDS)

NOT TO SCALE

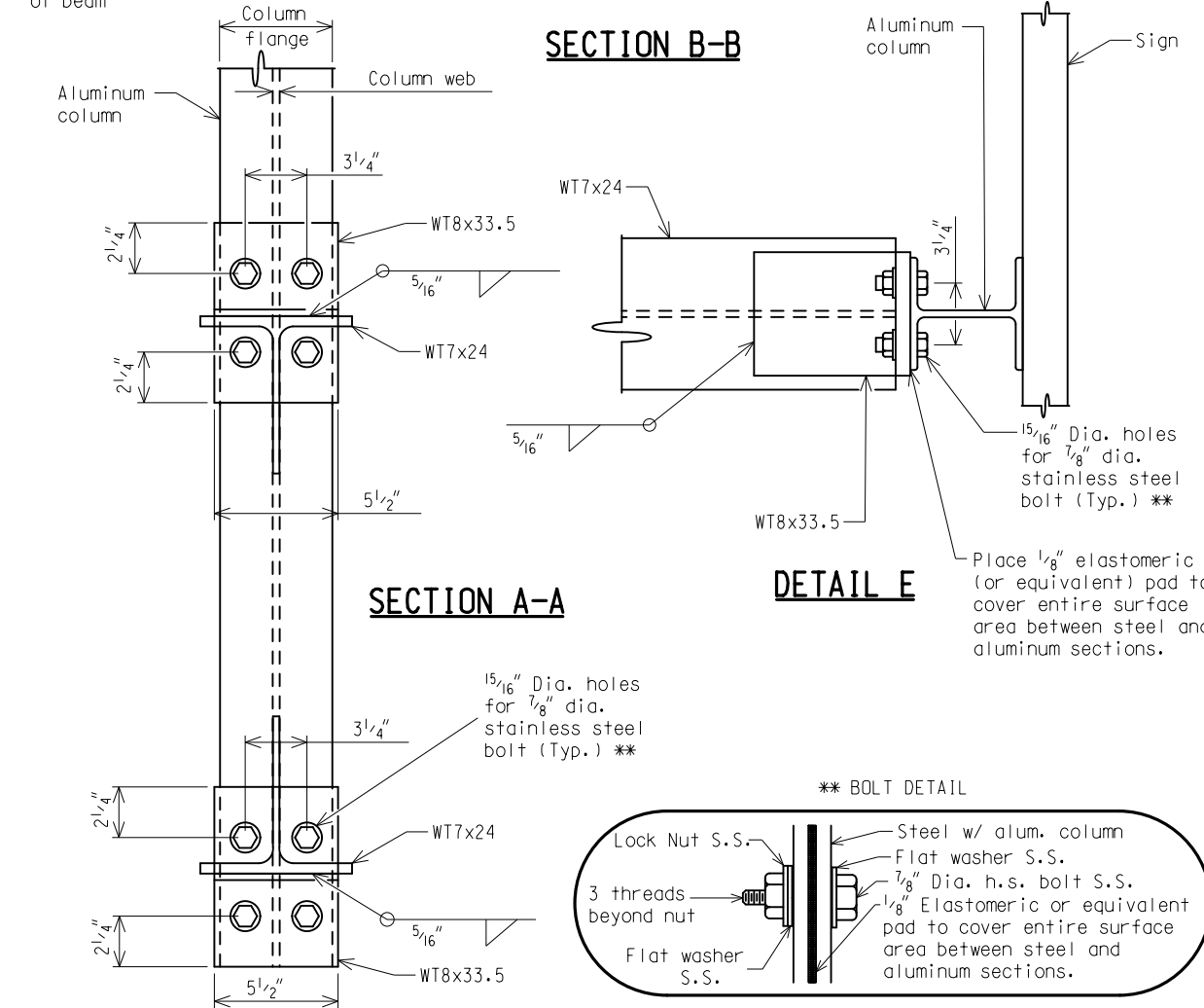
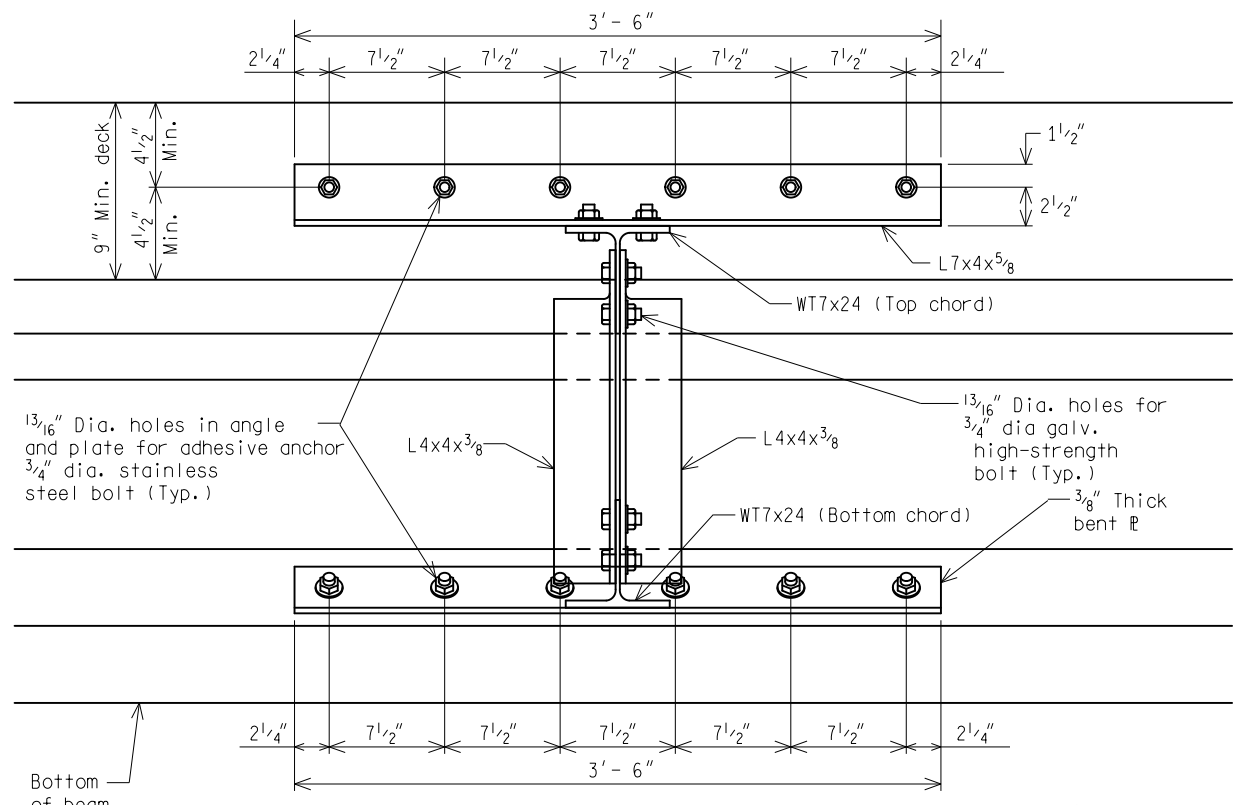

SECTION B-B

SECTION A-A

DETAIL E

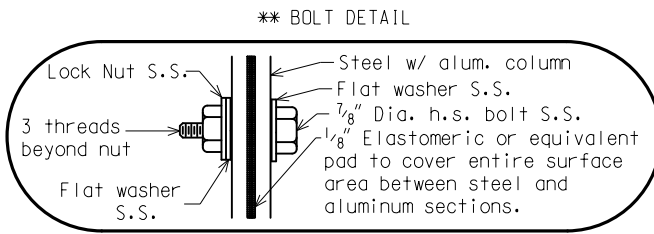

NOT TO SCALE

FLANGE DIMENSIONS				
PRESTRESSED I-BEAM DEPTH	A	B	D	E
28" (Type I)	4"	3 1/16"	2 13/16"	2 13/16"
36" (Type II)	4"	4 1/2"	2 13/16"	2 13/16"
45" (Type III)	4 1/2"	6 1/8"	3 3/16"	3 3/16"
54" (Type IV)	5 1/2"	7 1/4"	3 7/8"	3 7/8"

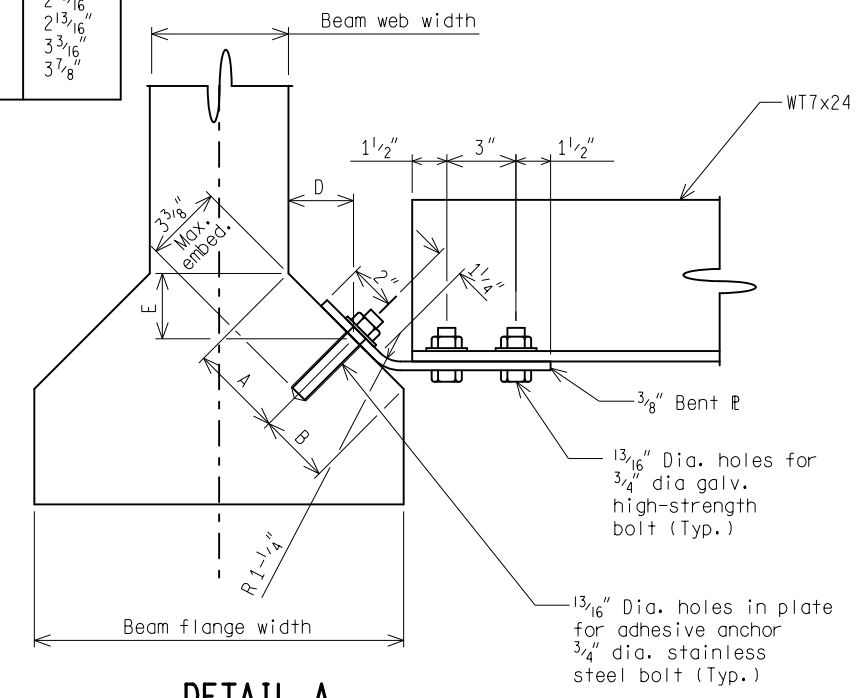

DETAIL A

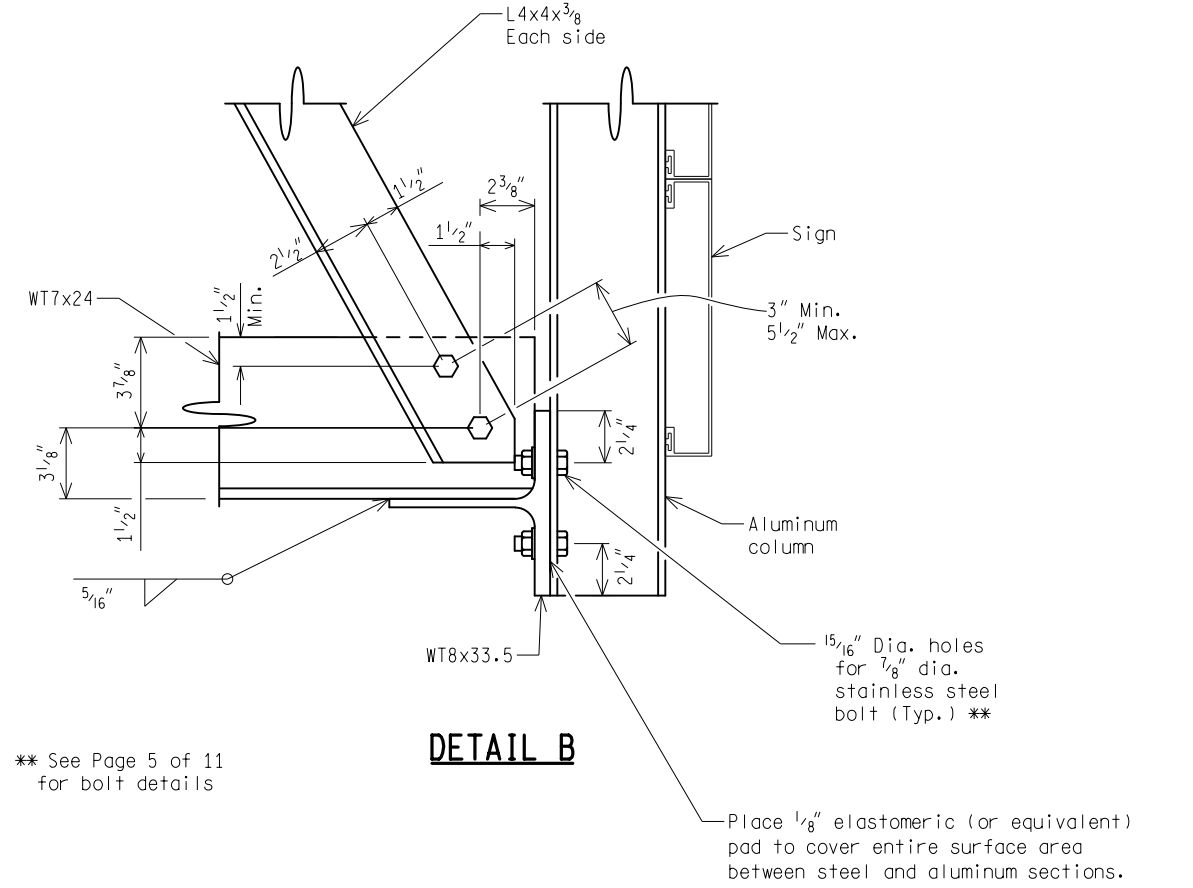

DETAIL B

** See Page 5 of 11 for bolt details

NOT TO SCALE

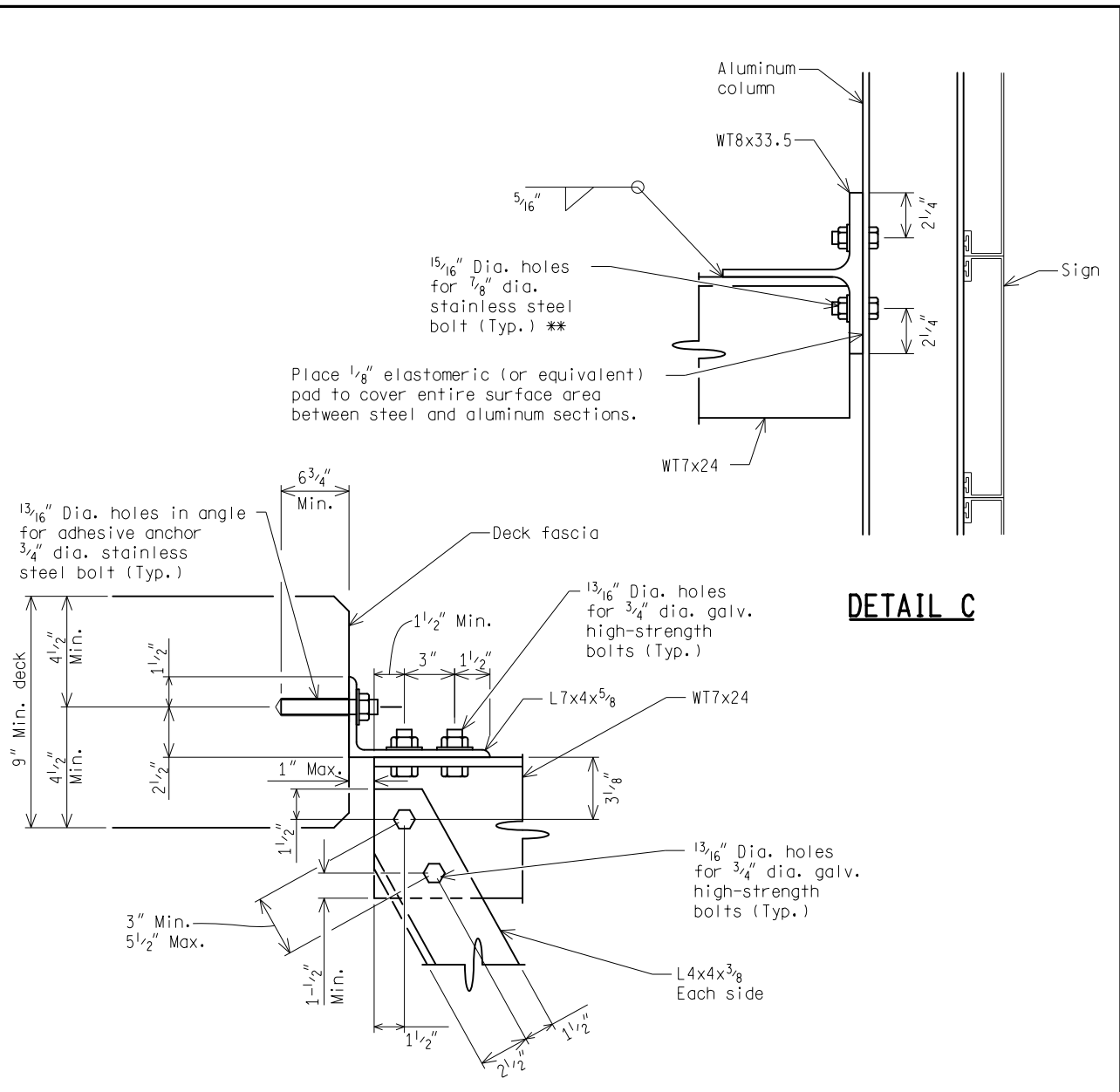

* ADHESIVE ANCHOR GROUP DESIGN ULTIMATE STRENGTHS				
BEAM TYPE	INSTALLED IN BEAM FLANGE		INSTALLED IN DECK FASCIA	
	TENSION (LBS)	SHEAR (LBS)	TENSION (LBS)	SHEAR (LBS)
I	9988	4115	18481	6608
II	12208	10236		
III	14649	10236		
IV	15981	10236		

* DESIGN ULTIMATE STRENGTH IS EQUAL TO THE ULTIMATE STRENGTH MODIFIED BY THE APPROPRIATE EDGE DISTANCE AND ANCHOR SPACING REDUCTION FACTORS RECOMMENDED BY THE MANUFACTURER.

** See Page 5 of 11 for bolt details

NOT TO SCALE

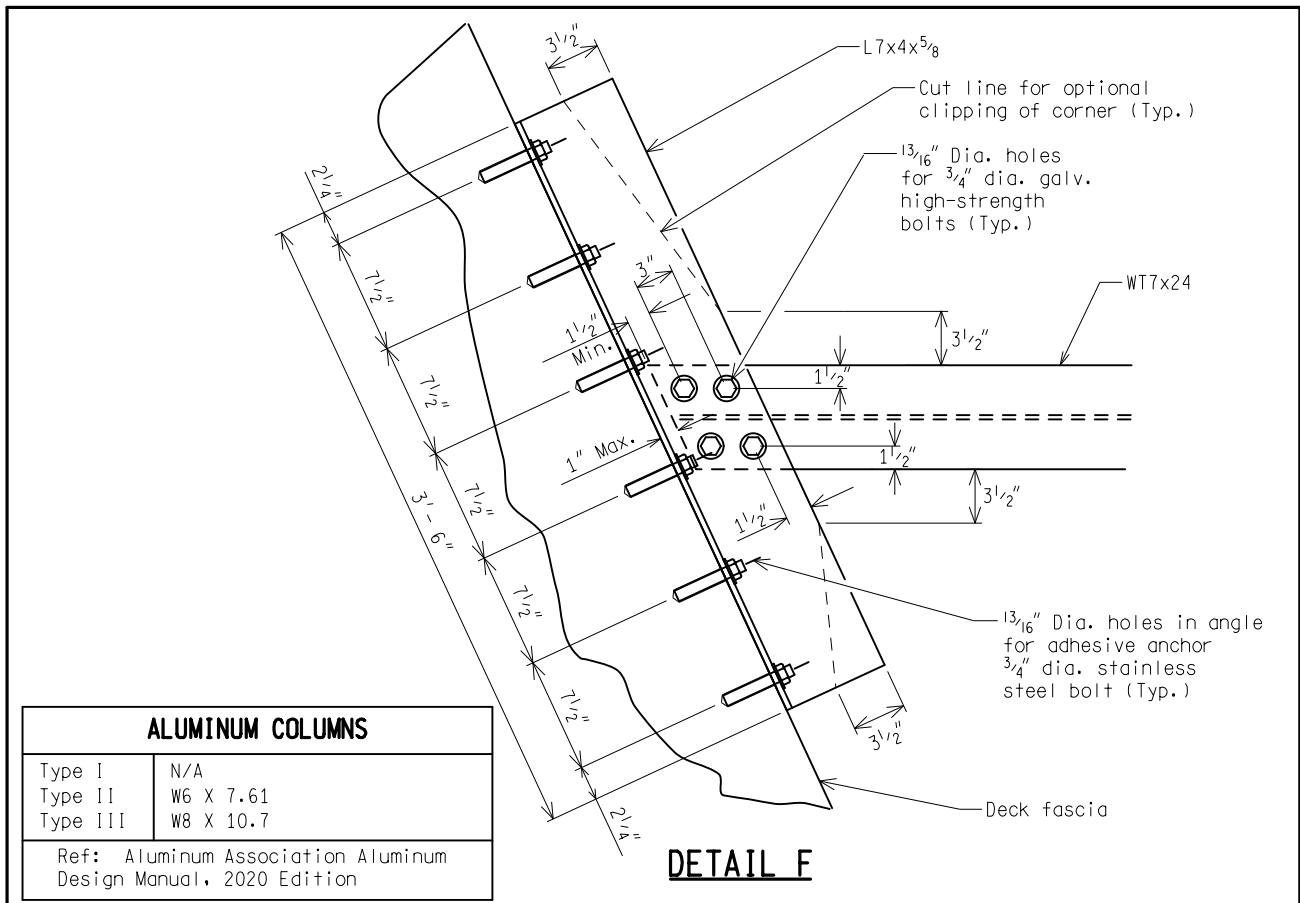

ALUMINUM COLUMNS	
Type I	N/A
Type II	W6 X 7.61
Type III	W8 X 10.7

Ref: Aluminum Association Aluminum Design Manual, 2020 Edition

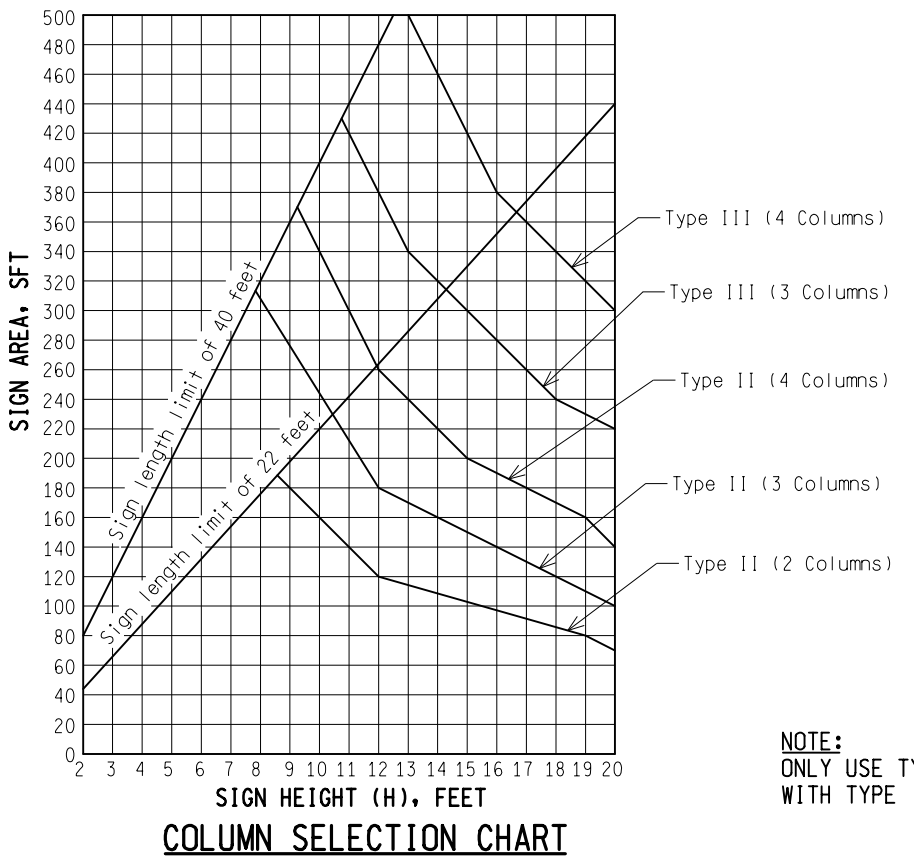

NOTE:
ONLY USE TYPE II COLUMNS WITH TYPE I BRIDGE BEAMS

NOT TO SCALE

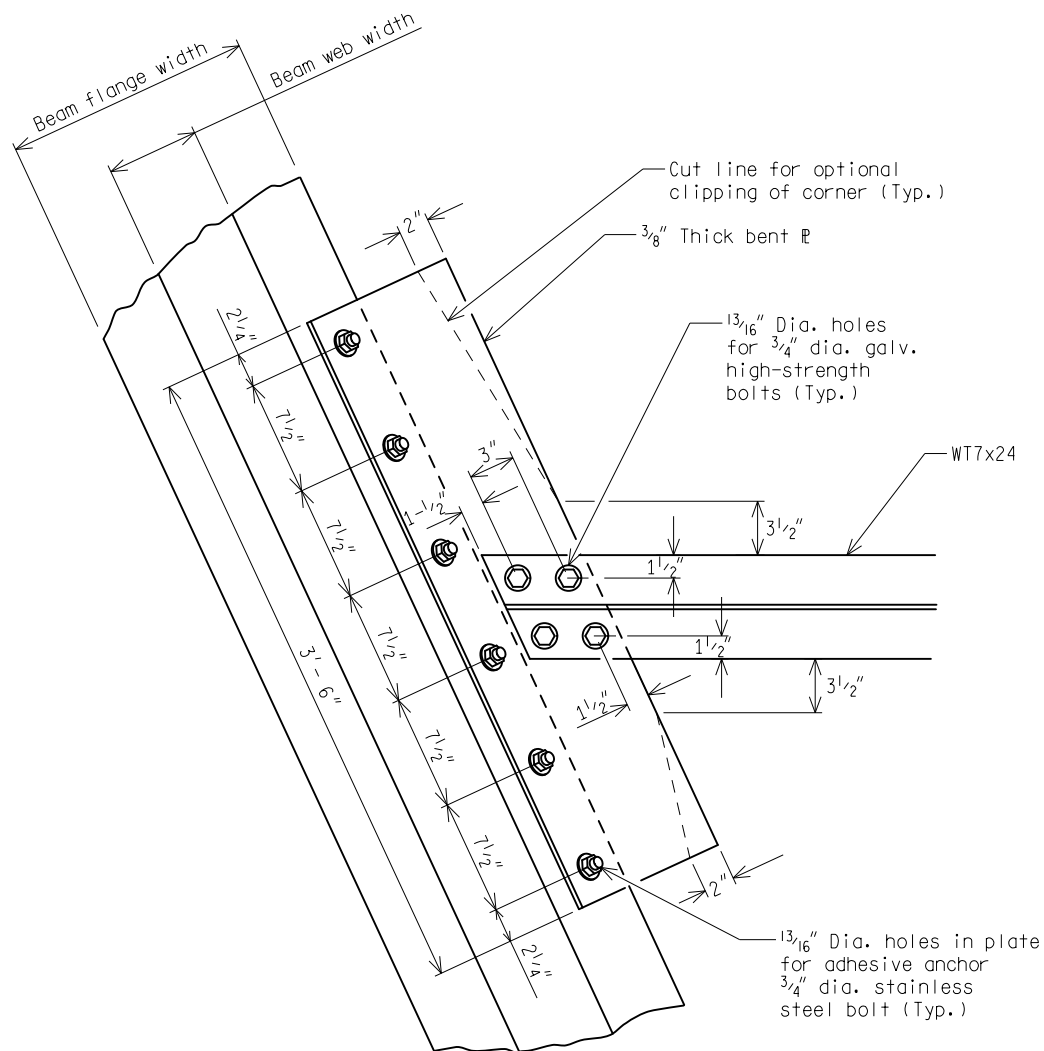

DETAIL G

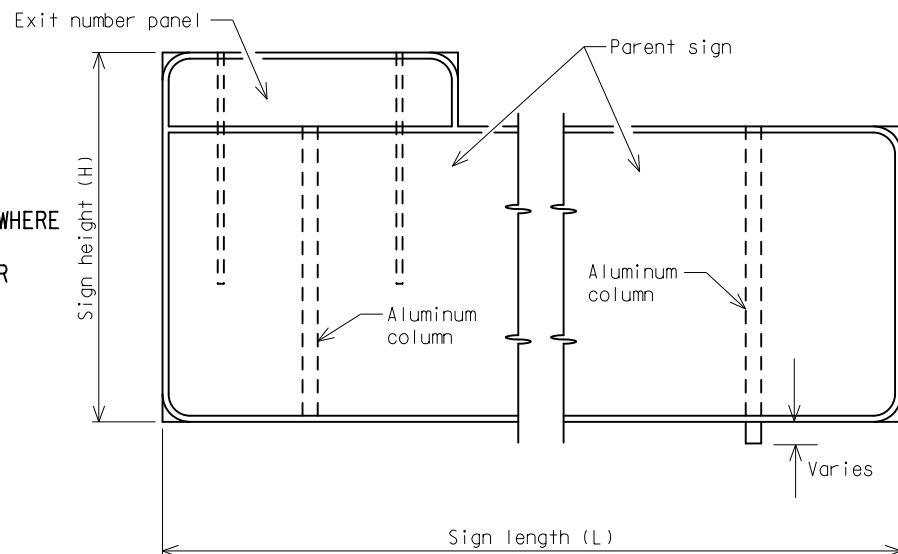

ELEVATION OF SIGN

NOTE:
SIGN HEIGHT IS MEASURED WHERE THE SIGN IS THE TALLEST INCLUDING ANY EXIT NUMBER PANELS.

NOTES:

1. Field verify bridge dimensions prior to fabrication.
2. Welding shall be in accordance with the Standard Specifications for Construction.
3. All structural steel members shall be hot-dip galvanized in accordance with the Standard Specifications for Construction.
4. All aluminum members shall be ASTM B 308 Aluminum Alloy 6061-T6 and shall conform to ASTM B 221.
5. Structural steel members shall conform to AASHTO M 270 Grade 36 or Grade 50S.
6. All high-strength bolts, nuts and washers shall be in accordance with Subsection 906.07 and installed according to Subsection 707.03.E.6 of the Standard Specifications except for stainless steel bolts, nuts and washers.
7. Stainless steel bolts and washers shall conform to ASTM A 320, Class 1, Grade B8. Nuts shall be self-locking nylon insert type and must conform to ASTM A 320, Grade 8F. Stainless steel nuts and washers shall always accompany stainless steel bolts. Stainless steel bolts, nuts and washers shall be used at connections with aluminum members. All other connections shall utilize galvanized high strength bolts, nuts and washers unless otherwise specified.
8. θ = Angle between sign and bridge fascia. Angle is a function of permissible cantilever length (C) and sign length.
9. All concrete anchors shall be chosen from the Qualified Product List in the MDOT Materials Source Guide. All concrete anchors shall be installed according to the manufacturers recommendations and subject to the requirements of Section 712.03.J of the Standard Specifications except that all field testing must demonstrate the anchor can develop 70 percent of the minimum Effective Ultimate Strength shown in the plans with less than 1/16 inch slip. Field testing up to 90 percent of the bolts Yield Strength is waived. Extreme caution shall be exercised when drilling holes for concrete anchors. Existing bridge plans shall be reviewed to determine the prestressing strand locations and to evaluate the risk of damaging prestressing strands associated with installing concrete anchors.
10. The bottom edge of the sign shall be horizontal when erected.
11. If replacing an existing sign support, existing holes in concrete shall not be reused and shall be filled with a non-shrink grout in accordance with Section 1005.02.B of the Standard Specifications for Construction.
12. Inspection of proposed locations shall be performed to determine viability of connection to existing bridge.
13. See Subsection 810.03.P of the Standard Specifications for Construction for bolt replacement in retained bridge mounted sign connections.
14. Removal of existing bridge sign connections shall be according to Subsection 810.03.U of the Standard Specifications.
15. See Section 810 of the Standard Specifications for bridge sign connections to existing bridges.
16. The design of this sign connection is based on the assumption that the deck concrete has a minimum Compressive Strength of 3000 psi and prestressed beam concrete has a minimum Compressive Strength of 5000 psi. If it is suspected that the concrete is of lesser strength or is in poor condition, this sign connection shall not be used.
17. Sign panel connections to aluminum columns shall have the same bolt arrangement as shown for sign panel connections to aluminum columns for cantilever and trusses (see typical plan Sign-700 Series).

NOT TO SCALE

NOT TO SCALE

NOTES:

- 18. All members are steel except aluminum columns.
- 19. The design of these bridge sign connections are according to the AASHTO LRFD Specifications For Structural Supports For Highway Signs, Luminaires And Traffic Signals, 1st Edition, with interim revisions through 2022.
- 20. These details are only to be used for structures with Type I, Type II, Type III or Type IV prestressed I-beam bridges with applicable concrete deck configurations.

NOT TO SCALE

MICHIGAN DEPARTMENT OF TRANSPORTATION	(SPECIAL DETAIL) F.H.W.A. APPROVAL	08/08/23 PLAN DATE	SIGN-810-B	SHEET 11 OF 11
---------------------------------------	---------------------------------------	-----------------------	------------	-------------------