

PCC PAVEMENT JOINT RESTORATION
AND REHABILITATION
(Federal Highway Administration NEEP Project 27)
Final Report

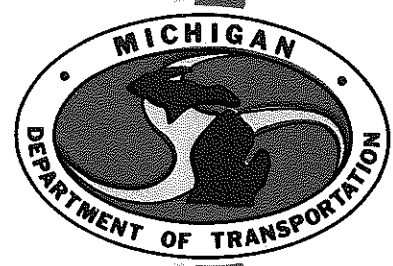

MATERIALS and TECHNOLOGY DIVISION

TE 278.2 S52 1989 c. 3
PCC pavement joint
restoration and
rehabilitation

TE 278.2 S52 1989 c. 3
PCC pavement joint
restoration and
rehabilitation

PCC PAVEMENT JOINT RESTORATION
AND REHABILITATION
(Federal Highway Administration NEEP Project 27)
Final Report

J. E. Simonsen
A. W. Price

Research Laboratory Section
Materials and Technology Division
Research Project 79 F-159
Research Report No. R-1298

Michigan Transportation Commission
William Marshall, Chairman;
Rodger D. Young, Vice-Chairman;
Hannes Meyers, Jr., Stephen F. Adamini,
Shirley E. Zeller, Nansi I. Rowe
James P. Pitz, Director
Lansing, June 1989

The information contained in this report was compiled exclusively for the use of the Michigan Department of Transportation. Recommendations contained herein are based upon the research data obtained and the expertise of the researchers, and are not necessarily to be construed as Department policy. No material contained herein is to be reproduced—wholly or in part—without the expressed permission of the Engineer of Materials and Technology.

SUMMARY

The objective of this project was to develop a joint repair detail that would function properly for a 10-year period. It was required that the repair be opened to traffic within eight hours and its construction would be adaptable to mass production techniques. As a first step to accomplish this goal, laboratory studies were conducted that led to the development of mechanized drilling of horizontal holes in the end faces of the existing slab. Connection to the existing slab was accomplished by grouting seven tie bars into drilled holes in the end faces of the existing slab. Load transfer was provided by sawing a 1/4 in. step at mid-depth of the slab. Length changes in the pavement were accommodated by installing a joint in the center of the repair. To obtain adequate eight-hour concrete strength a nine-sack concrete mix accelerated with calcium chloride was used.

The developed techniques and materials were field tested, first on experimental installations conducted by Department personnel and then on a contract consisting of 2700 lane repairs. The experimental repairs utilizing step-cut tied joints proved successful and were specified in 2100 of the contract repairs. In the remaining 600 repairs, ten loose fitting dowels (1-5/16-in. diameter dowels inserted in 1-3/8-in. diameter holes) were used in the repair joints. This type of dowelled joint had performed satisfactorily since their installation in 1972 in a few experimental repairs on 196 in Kent County.

Although the experimental repairs using step-cut tied end joints performed well, those installed under contract performed poorly. Based on test section measurements nearly 70 percent of the repairs failed during the seven years since their construction. The failures were found to have occurred in the epoxy grouted portion of the tie bars. The bars pulled out of the epoxy grout either because the grout failed to harden (improper mixture proportioning) or an insufficient amount of grout was provided to encapsulate the bars. Since this project was constructed, new equipment for mixing and injecting grout in horizontal holes has been developed and grouted-in tie bars have been used successfully on several Michigan projects.

The performance of loose fitting dowelled joints has been monitored on projects on I 94, I 75, US 23, and I 75 Business Loop in Pontiac. The measurements indicated that after five years service 98 percent of the joints have vertical offsets of less than 3/16 in. and for the remaining 2 percent the offset is 1/4 in. or less. The performance of loose fitting dowelled joints depends on good base support, properly sized dowel holes, exact matching of the new concrete surface to the elevation of the existing pavement surface, and good durability and abrasion characteristics of the aggregate used in the concrete pavement to be repaired.

It is concluded that, when properly constructed, loose fitting dowelled joints will provide several years of service without excessive faulting. It is recommended, however, that loose fitting dowels be used only on pavements 15 years or older, and on newer pavements and on pavements with aggregate of low abrasion values the use of epoxy grout for fastening the dowels is recommended.

INTRODUCTION

In 1968, the Michigan Department of Transportation began an experimental program to develop concrete repairs for use on concrete pavements. As a result of this work, a repair procedure involving full-depth replacement of distressed slab areas was adopted in 1972. The procedure involved full-depth diamond blade sawing of the repair limits, lifting out the distressed areas without disturbing the base, and using precast slabs or a 9-sack concrete mix with calcium chloride added for early set and strength gain. The repairs utilized either undowelled expansion or contraction joints at the transverse repair limits.

During the experimental period, several joints were constructed utilizing dowels in the repair joints. These dowels were installed by drilling holes in the vertical end faces of the repairs into which the dowels were inserted. The drilling process used at the time required 35 minutes to drill the required number of dowel holes for each repair. The process was labor-intensive and the drill would often 'hang-up' in the holes, especially if the steel reinforcement was encountered.

Because of the difficulty and expense involved with installing dowelled joints, repairs using undowelled joints became standard until 1982. Evaluation of the undowelled repairs indicated that they would serve satisfactorily for about five years before excessive faulting developed. At the time repairs were intended as an interim procedure for maintaining the pavements before an overlay would be placed or the pavement reconstructed. However, the unforeseen decrease in funding, coupled with increased deterioration of the pavement which increased maintenance expenditures, necessitated the deference of overlays as well as reconstruction. Consequently, many of the undowelled repairs are now serving well beyond their intended time. As a result, excessive faulting has developed at some of those older repairs, especially on heavy commercial routes.

As revenues kept decreasing, it was evident that it would be necessary to maintain the concrete pavements for more years than anticipated. Therefore, repairs that would retain their smoothness for ten years or more were needed. To accomplish this, the Department initiated an experimental study in early 1979 to develop a non-faulting joint for use with full-depth concrete repairs. A year later, the Department joined the FHWA sponsored NEEP Project 27, "PCC Pavement Joint Restoration and Rehabilitation."

Background

The pavement design for which the repairs were developed is a 9-in. reinforced concrete slab with 99-ft joint spacing. The joints contain 1-1/4-in. plain steel dowels spaced 12 in. on centers and a baseplate beneath the dowel assembly's transverse centerline. The joint grooves were formed in the fresh concrete and sealed with a hot-poured rubber-asphalt sealant. Concrete pavements of this design range in age from 25 to 40 years.

The most common distress that occurs is the failure of transverse joints. These failures are caused by moisture, especially saltwater from snow removal, entering the joints through failed seals. The moisture is trapped by the baseplate and a triangular area of concrete bounded by the plate and up to the dowel is reduced to rubble. The severity of the failure is related to the moisture absorption characteristics of the aggregate used in the concrete: the more susceptible the aggregates are to moisture absorption, the more severe the deterioration.

Because the bottom of the slab has deteriorated as described, the repairs consist of full-depth slab replacement. Since the failures are confined to the slab itself and not related to the pavement foundation (which generally consists of a clay grade, 10 in. of sand, and a 4-in. aggregate base), the repair procedures do not require any reconstruction of the base materials.

In the sixties, the Department's concrete pavement design was changed to shorten the slab length to 71 ft, construct the joint grooves by sawing, use preformed neoprene compression seals, and eliminate the baseplates. Corrosion resistant coatings have been required on dowel bars since 1974 and slab lengths were further reduced to 41 ft in 1979. These design changes have substantially retarded the deterioration at the bottom of the joints. Because the joint cross-section is basically still intact and capable of resisting compressive forces, the Department is currently implementing a preventive maintenance program for these pavements. The procedures involve partial-depth joint repairs, seal replacement, and crack sealing.

Objective

The project objective was to develop a joint detail for use between a new and existing reinforced concrete slab that would retain its smoothness for at least 10 years. It must have sufficient strength to carry traffic within eight hours after installation and its construction must be adaptable to mass production techniques.

Scope

The scope of the project consisted of three parts:

- 1) Experimental laboratory work to develop suitable joints, installation techniques, and equipment.
- 2) Construction of selected joints for field evaluation. This part of the project was done in three stages:
 - a) Installation of a few repairs, using two types of joints on a roadway with light commercial traffic, primarily to determine the feasibility of construction and evaluate their performance under light traffic loads.

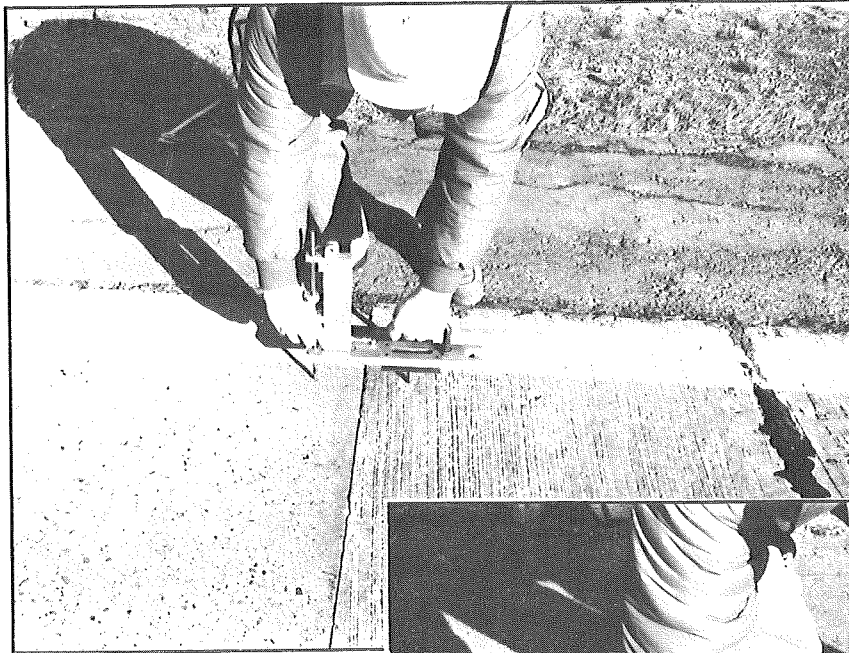

(a) Measurement of vertical change to the nearest 1/32 in. The two legs of the instrument fit into counter drilled holes in the reference pins. The instrument is held level and vertical difference between the length of the movable and the fixed leg is read on a linear scale.

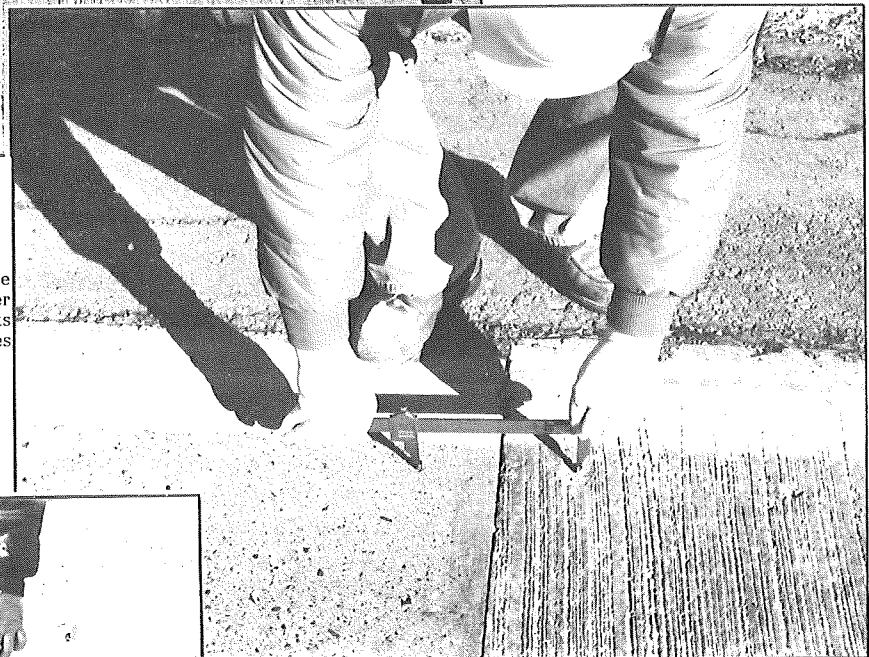

(b) Measurement of horizontal change to the nearest 0.001 in. The vernier caliper is equipped with tapered points which fit into the counter drilled holes in the reference plugs.

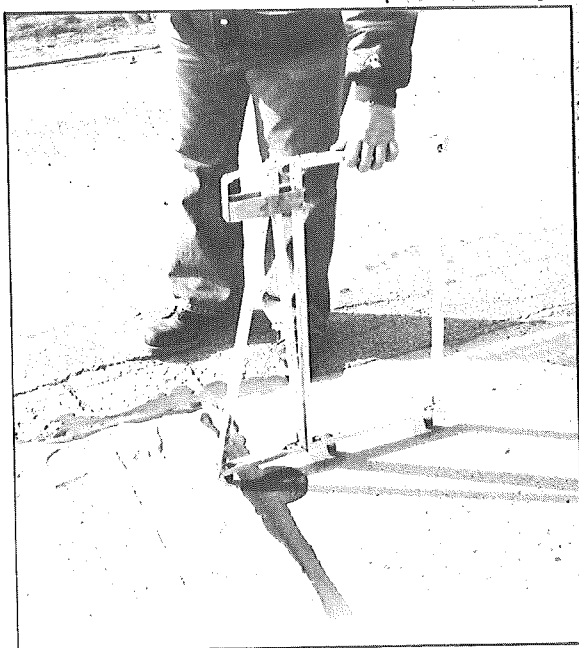

(c) Measurement of vertical change to the nearest 1/16 in. The instrument rests on three feet and is hinged between the second and third feet. The upward or downward rotation is measured as the vertical displacement on a linear scale mounted to the handle.

Figure 1. Measurement of vertical and horizontal movements at repair joints.

b) A limited number of the experimental repairs were installed on a major roadway carrying a heavy commercial traffic volume, to evaluate their performance under such loading.

c) A contract to construct a large number of the repairs was let to determine their suitability for use on a production-type project and to obtain cost information when large quantities are involved.

3) Evaluation of the performance of the repairs by conducting measurements on joint movements, joint faulting, and visual inspections of the repair slabs.

Construction reports (MDOT Research Reports R-1179 and R-1235) covering the construction operations were issued in April 1981 and November 1983, respectively. These reports cover the performance of the experimental field repairs. Pertinent parts of the earlier reports are included herein as well as a photographic sequence of the construction operations.

PERFORMANCE EVALUATION

To determine whether the objective of the project (to develop a repair joint that would retain its smoothness for 10 years) was achieved, measurements were made twice a year (summer and winter) to obtain data on vertical joint movement. All joints included in Stage 1 and 2, and representative samples selected on the Stage 3 project, were instrumented with stainless steel plugs. These plugs were used for reference points when measuring vertical movements, and for horizontal movements at tied joints. In addition to measuring the performance of the above joints, the performance of dowelled repair joints was also measured on contract repairs constructed on US 23, I 75, and Business Route 1 75 in Pontiac. The reference points on these projects consisted of small epoxy patches on which the instrument could be placed when measurements were made. The instruments used in measuring the joint movements are shown in Figure 1.

In nearly all cases the vertical measurements indicated that the repair slabs will settle at the leading joint and rise at the trailing joint. Figure 2 illustrates the common mode of faulting at repair slabs.

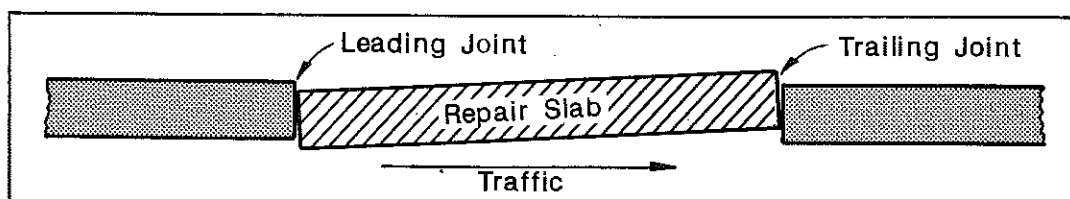
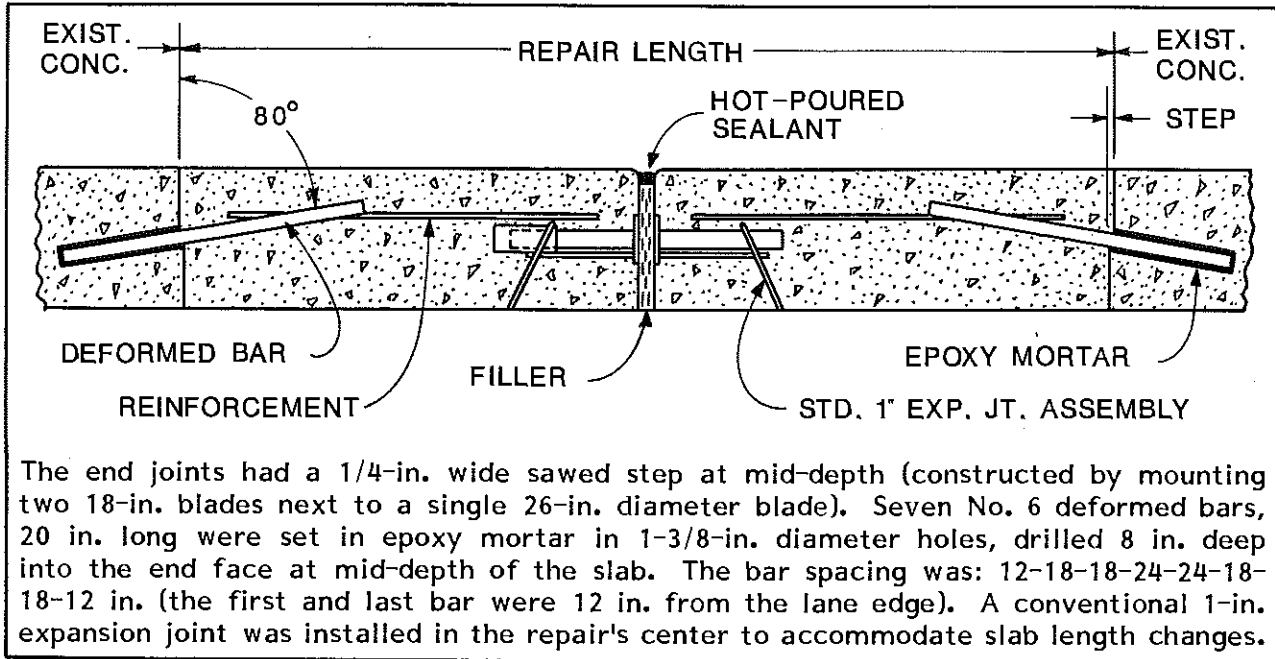

Figure 2. Sketch showing most common mode of faulting.



Step-cut tied end joints (expansion joint in center)

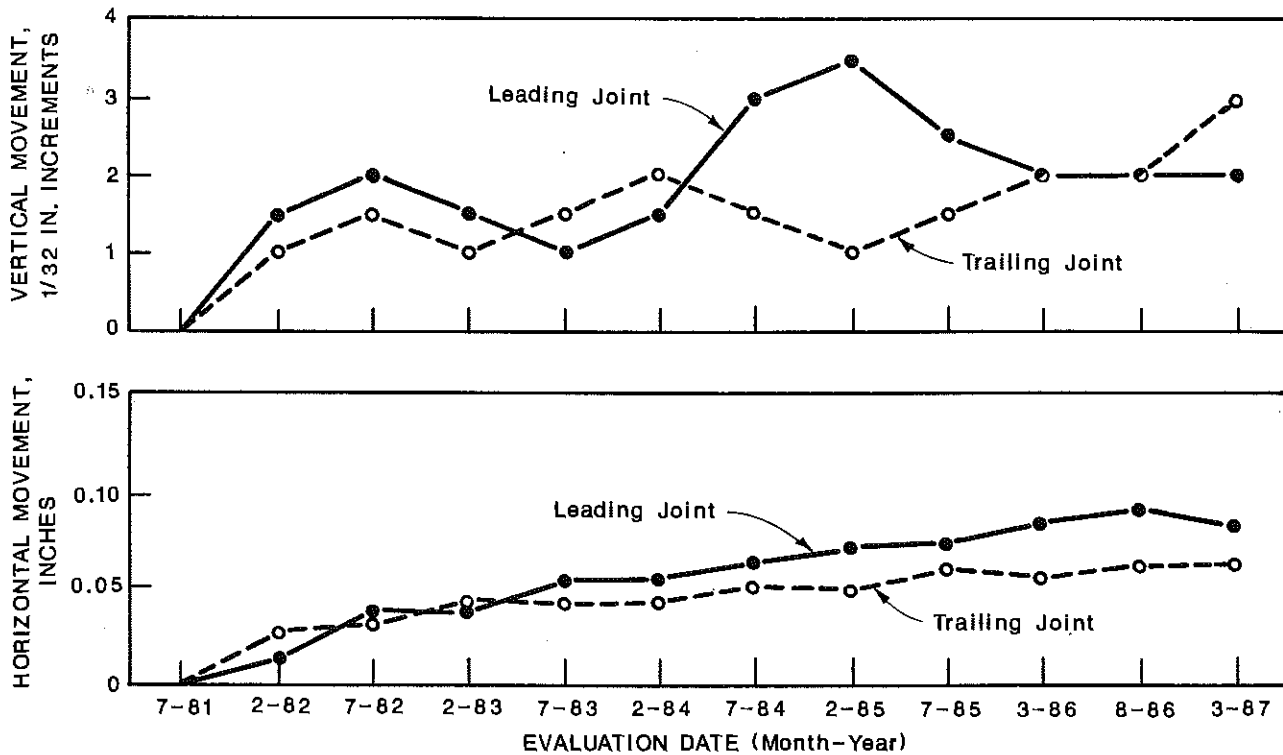

Figure 3. Joint design and average vertical and horizontal movement at step-cut joints (stage 1 repairs on US 127, subjected to 520,000 ESALS).

Stage 1 Repairs

The pavement on which the construction feasibility work was conducted is located on US 127 between I 96 and M 36 south of Lansing. It was 15 years old in 1981 when the repairs were constructed and it consists of two 24-ft roadways of 9-in. thick reinforced concrete. The joints are spaced 71 ft apart and are dowelled with 1-1/4-in. diameter bars, 18 in. long on 12-in. centers. The joint grooves were sawed and then sealed with preformed neoprene seals. The US 127 route carries light commercial traffic and it is estimated that the repairs have been subjected to approximately 520,000 18-Kip Equivalent Single Axle Loads (ESAL) since they were constructed.

A total of four experimental repairs (eight lane repairs) were constructed. Two had step-cut end faces and two had their end faces coated with an epoxy bonding agent prior to concrete placement. Figure 3 shows a stepcut end joint and gives a description of the joints, along with a graph showing the movement changes that have occurred through the winter of 1987. The same information is given in Figure 4 for the joints treated with the epoxy bonding agent. The step-cut and epoxy coating were utilized to reduce the number of tie bars required to provide adequate load transfer.

As a first step in evaluating the joints' performance, cores were taken through the tie bar locations to verify proper bonding of the bars in both the new concrete and the epoxy grout. As can be seen in Figure 5, the bars were found to be properly bonded to the concrete and also to the epoxy grout. Cores were also taken through the joints to examine the width of the joint between the new and existing concrete. It was found that at one of the joints, the epoxy bonding coat had failed (Fig. 6) but at the other three joints the bond was good. The joints with the step-cut were tight at the bar level and below but noticeably wider at the surface (Fig. 6).

As can be seen in Figures 3 and 4, the joint movements indicate that they are still performing satisfactorily. The vertical movement has cycled between 1/32 and 3/32 of an inch and the horizontal surface measurements have increased somewhat since 1981 and were in the 0.07 to 0.08-in. range when the last measurements were taken in 1987. The surface condition of a repair with step-cut joints and one with epoxy bonded joints are shown as they appeared in early 1989 in Figure 7.

The main advantage of using tied joints is that they are smooth riding and noise free compared to contraction or expansion joints. However, in cases where the failure has occurred at joints, such as on US 127, it is necessary to provide a dowelled joint in the center of the repair to accommodate slab length changes. At failures in the interior portion of a slab there is no need to provide a center joint; therefore, the use of tied end joints results in a good riding repair.

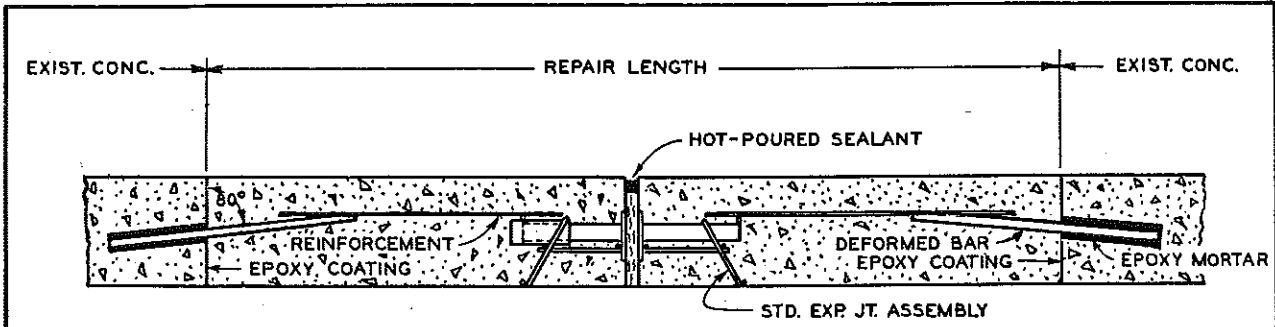

The end joints were sawed full-depth and an epoxy bonding coat applied to the end faces prior to concrete pouring. Seven No. 6 deformed bars, 20 in. long were set in epoxy mortar in 1-3/8-in. diameter holes, drilled 8 in. deep into the end face at mid-depth of the slab. The bar spacing was: 12-18-18-24-24-18-18-12-in. (the first and last bar were 12 in. from the lane edge). A conventional 1-in. expansion joint was installed in the repair's center to accommodate slab length changes.

Repair with epoxy coated end limits

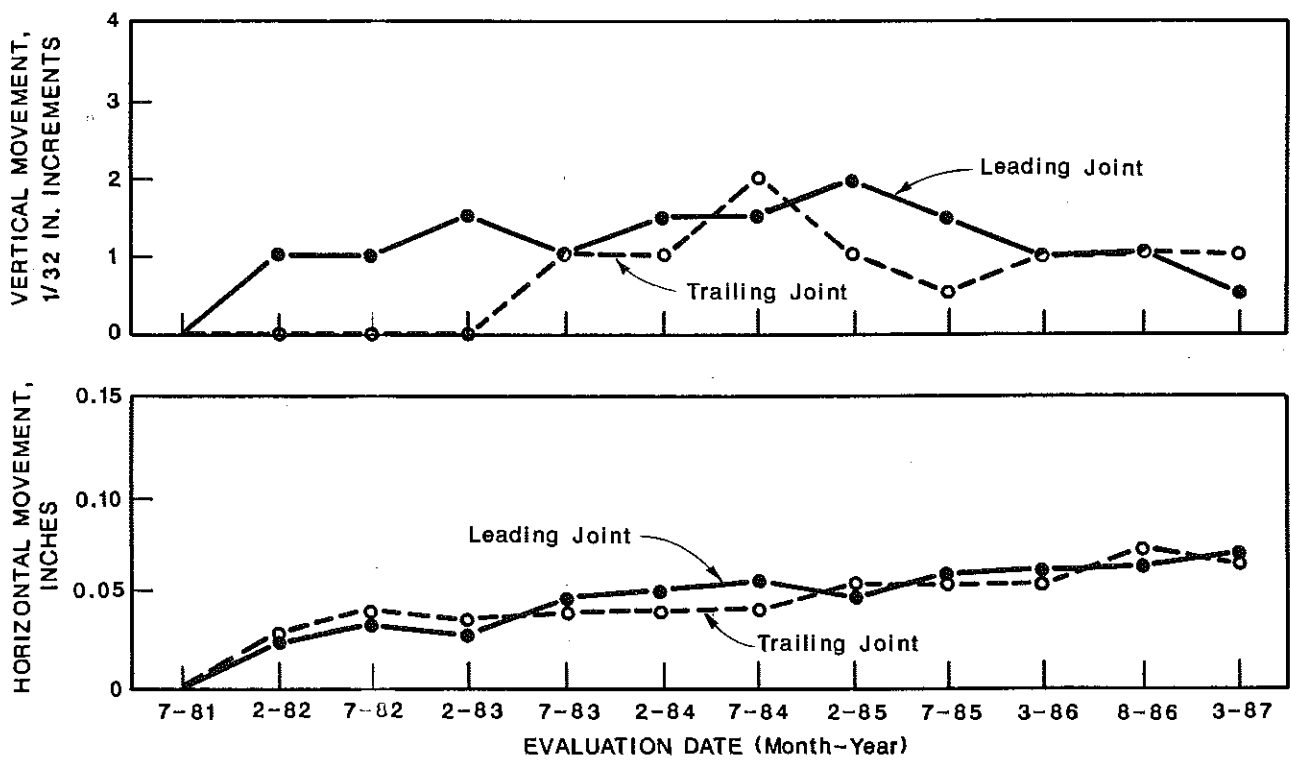

Figure 4. Joint design and average vertical and horizontal movements at epoxy coated joints (stage 1 repairs on US 127, subjected to 520,000 ESALS).

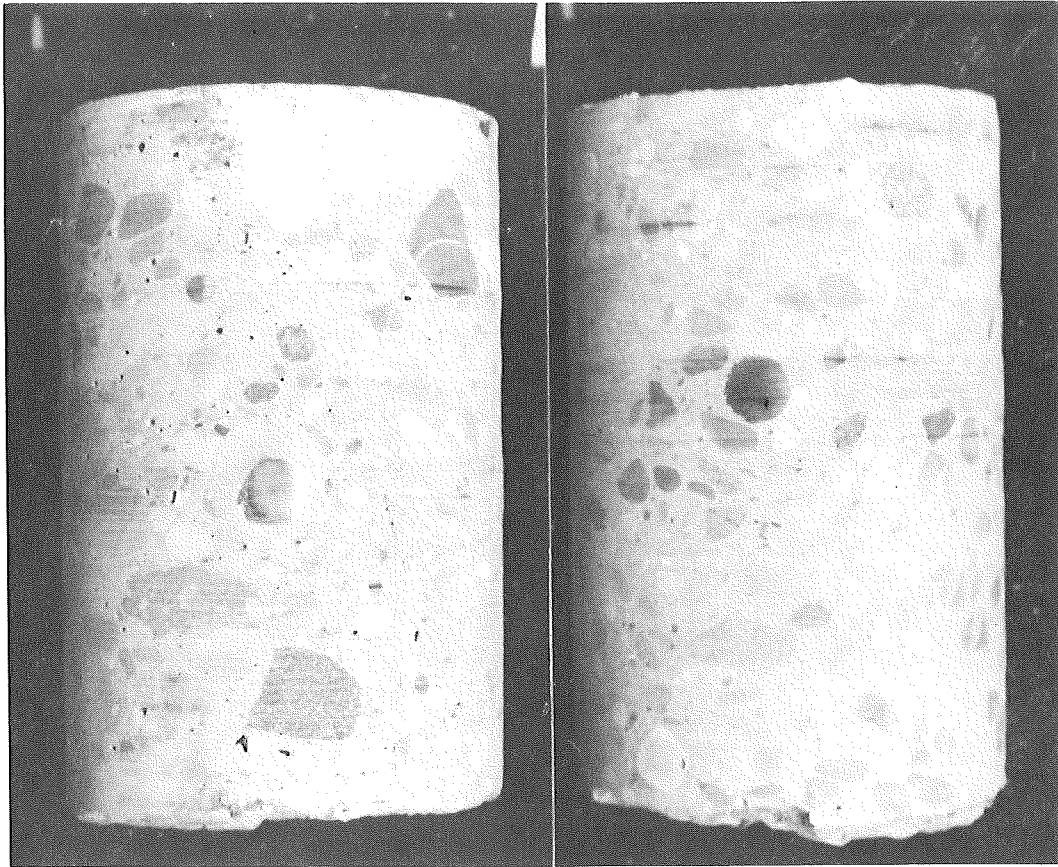
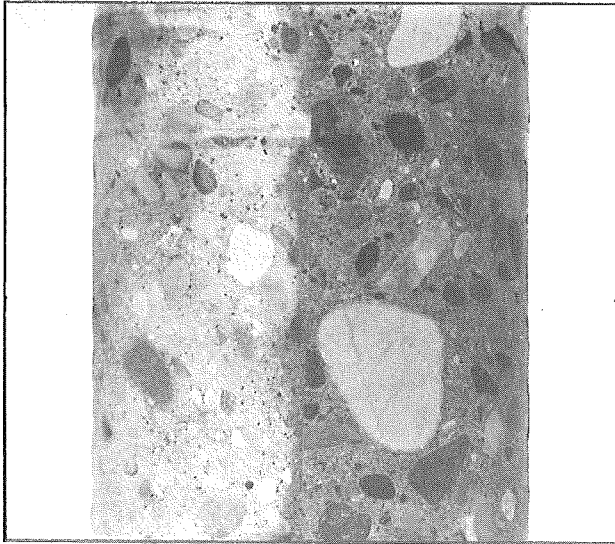
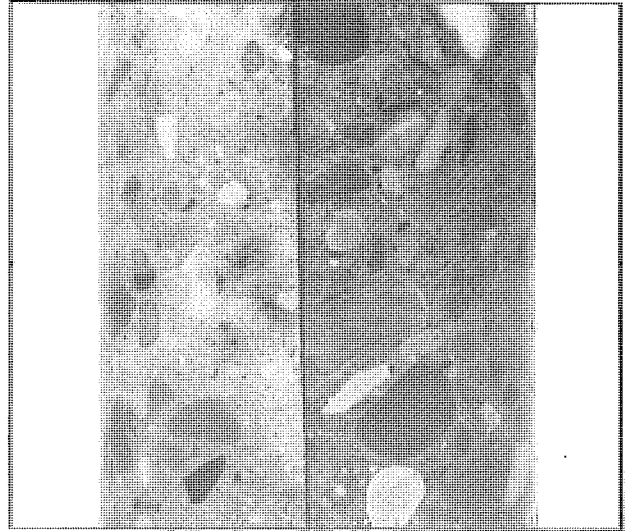

Figure 5. Cores taken through the tie bar location to examine bonding characteristics. The left core shows the bar properly embedded in the epoxy grout and the right core shows proper bonding in the new concrete.

On the basis of the early evaluation of these repairs it was decided that the repair utilizing the step-cut joint should be further evaluated on a heavy truck route. In addition, several other repair designs would be tested on the experimental section. In conjunction with the construction of the experimental repairs by Department forces, construction of 2700 lane repairs by contract would take place. Of these 2700 repairs, 2100 would use the step-cut type of repair and the remaining 600 repairs would be dowelled by inserting 1-5/16-in. dowels into 1-3/8-in. drilled holes in the existing end faces. The selection of repairs with loose fitting dowels was based on 10 years of excellent performance of repairs using this joint design on I 96 in Kent County.



◀ (A)



▲ (B)

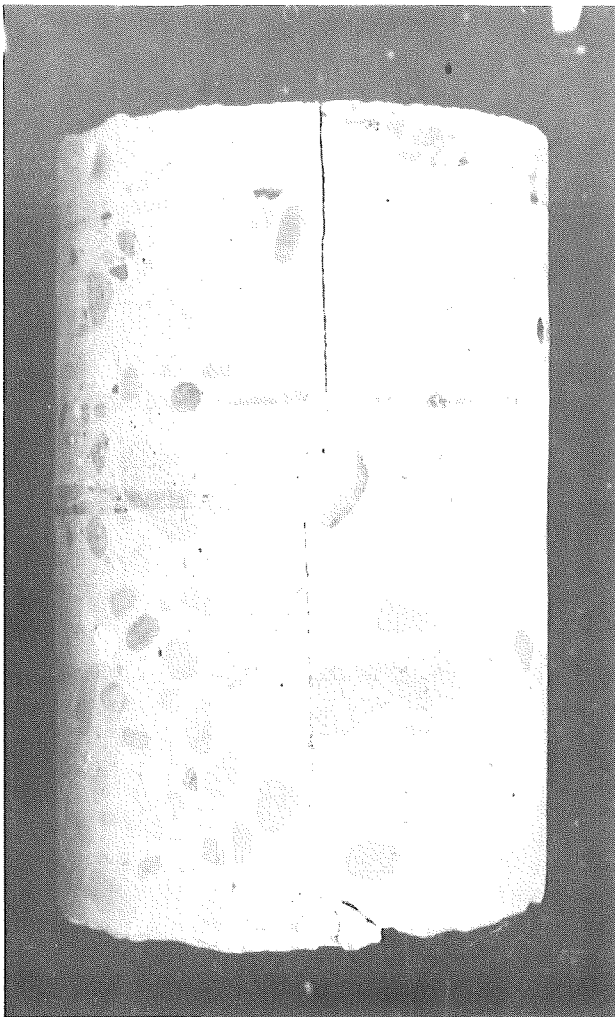

◀ (C)

Figure 6. Cores taken through joints. Good epoxy bond (a), failed epoxy bond (b), and typical tied joint showing decreasing width from top to bottom (c).

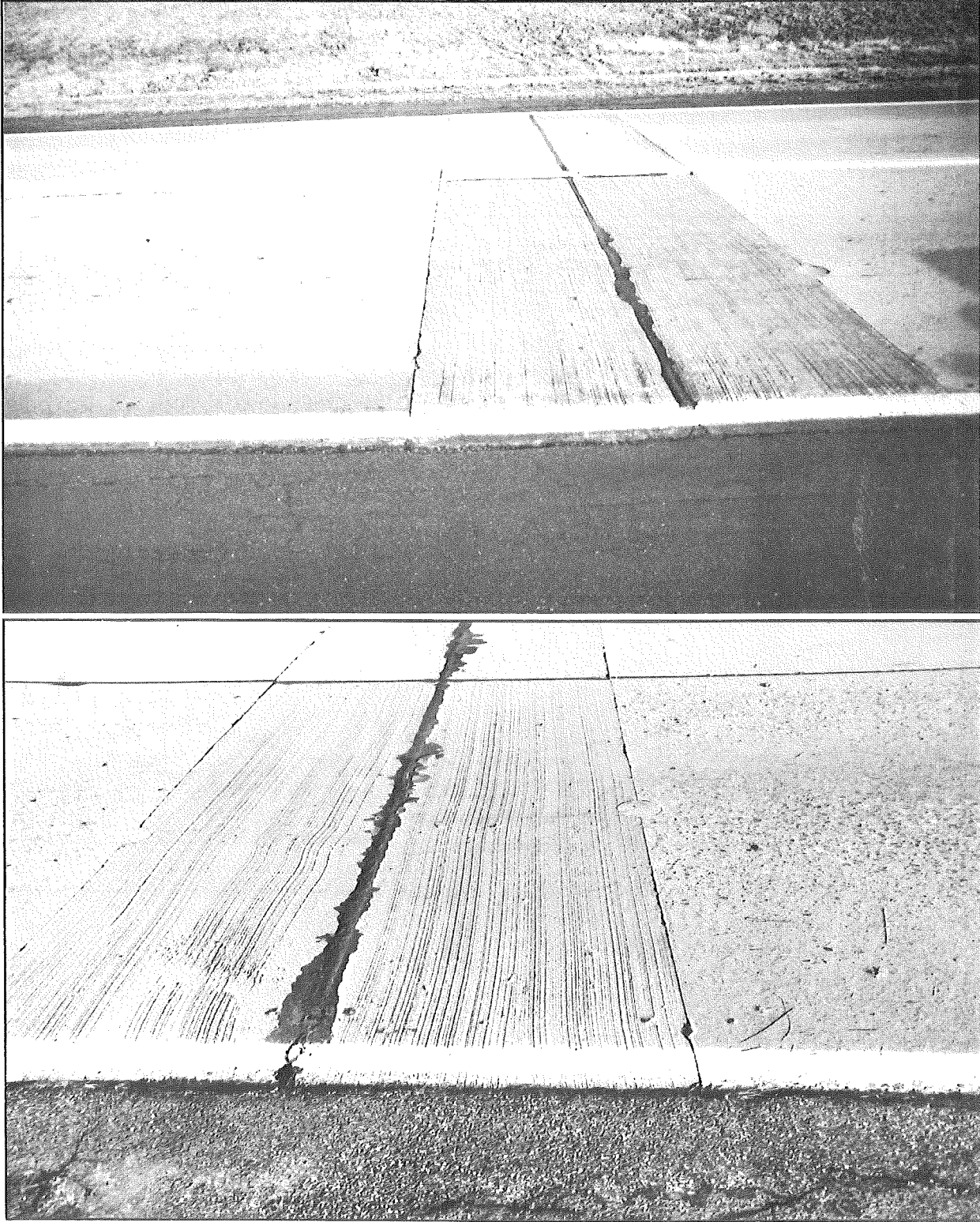
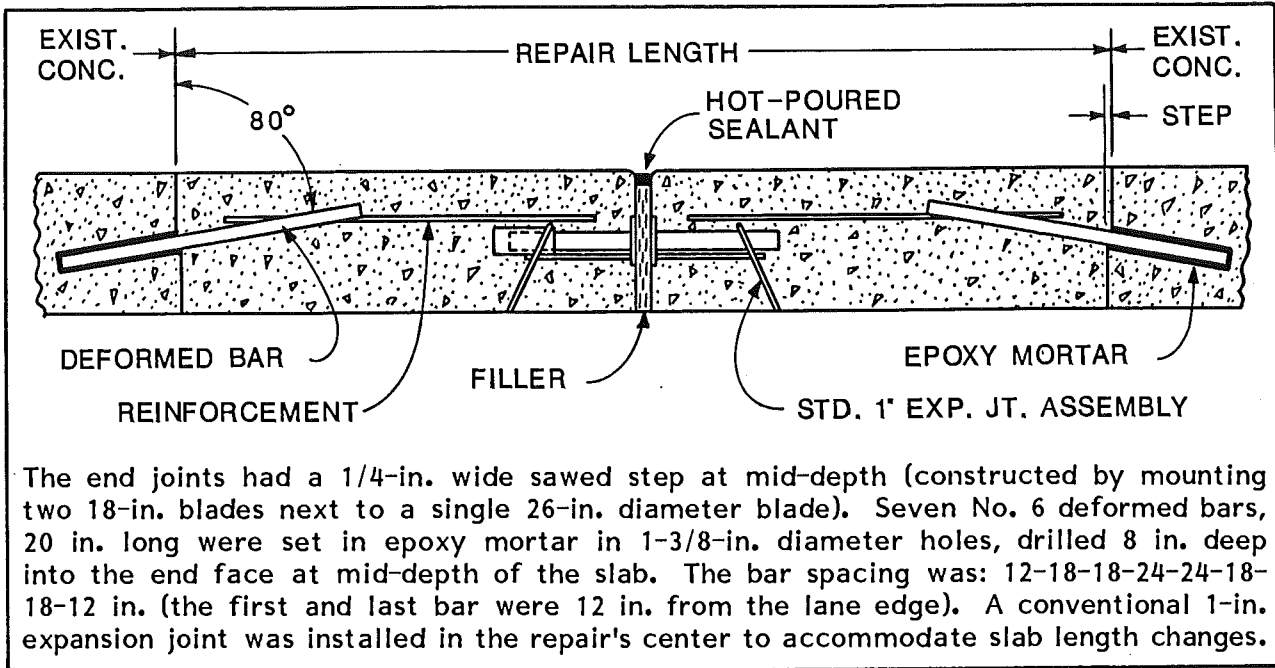

Figure 7. Condition of stage 1 repairs on US 127, after eight years service. Epoxy bonded joints (top), step-cut joints (bottom).



Step-cut tied end joints (expansion joint in center)

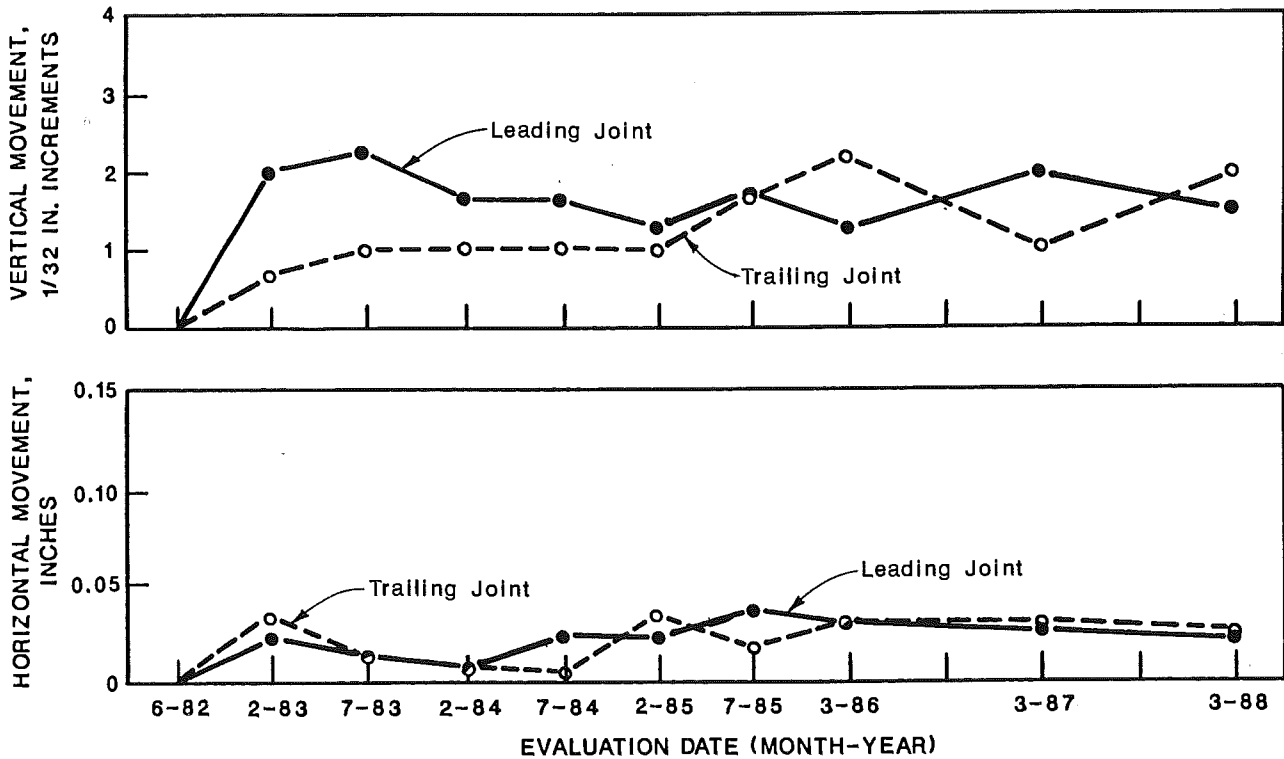

Figure 8. Joint design and average vertical and horizontal movement at step-cut tied joints (stage 2 repairs on I 94, subjected to 1,800,000 ESALS).

Stage 2 Repairs

The experimental repairs were constructed in 1982 on I 94 in Calhoun County on the westbound roadway. This portion of I 94 was built in 1961 and consisted of two 12-ft lanes of 9-in. reinforced concrete. The slab lengths were 99 ft and joint grooves were formed in the fresh concrete. A hot-poured rubber-asphalt sealant was used. A baseplate was placed at the transverse centerline of the load transfer dowel assembly. The pavement section on which the experimental repairs were located was recycled in 1988, six years after the repairs were made. It is estimated that before their removal they had been subjected to 1,800,000 18-Kip ESAL, which is approximately 3.5 times the loading experienced by the Stage 1 repairs on US 127.

Eighteen experimental repairs (36 lane repairs) were installed, three each of six different designs. They are: step-cut tied end joints with an expansion joint in the center, straight-cut tied end joints with an expansion joint in the center, dowelled contraction joints, dowelled expansion joints, tied end joints, and inverted T-slabs. Figures 8 through 13 show sketches of the joints and give descriptions of them along with graphs showing their performance during their service life.

Two of the repairs utilizing step-cut tied joints have failed, one in 1983 and one in 1984. The failures occurred as a result of slippage of the tie bars grouted into the existing concrete. Joint openings as large as 0.5 in. were measured at the time the failures were noted. The remaining joints of the third repair have functioned properly with the horizontal movements not exceeding 0.04 in. (Fig. 8). The graph in Figure 8 showing the vertical movement includes the measurements at the failed tied joints; however, as shown the maximum average offset measured was just slightly over 1/16 in.

The repairs with the straight-cut end faces (Fig. 9) utilizing nine No. 8 deformed bars performed very well. As can be seen, both the vertical and horizontal movements remained quite small while the repairs were in service.

The dowelled contraction joints (Fig. 10) and the dowelled expansion joints (Fig. 11) have moved in a quite similar manner. Both showed a 1/16-in. vertical offset at the first winter measurement and since then have varied from 1/32 to slightly over 3/32 in.

The joints constructed with nine No. 6 deformed tie bars (Fig. 12) have performed just as well as the tied joints where No. 8 bars were used. The vertical movements have been in the 1/32 to 1/16 in. range and the horizontal movements stabilized at 0.06 in. in 1985.

The greatest vertical offset was measured at the inverted T-slab joints (Fig. 13). By the time the pavement was recycled the offset measured slightly over 5/32 in. at the leading joint and slightly more than 7/32 in. at the trailing joint.

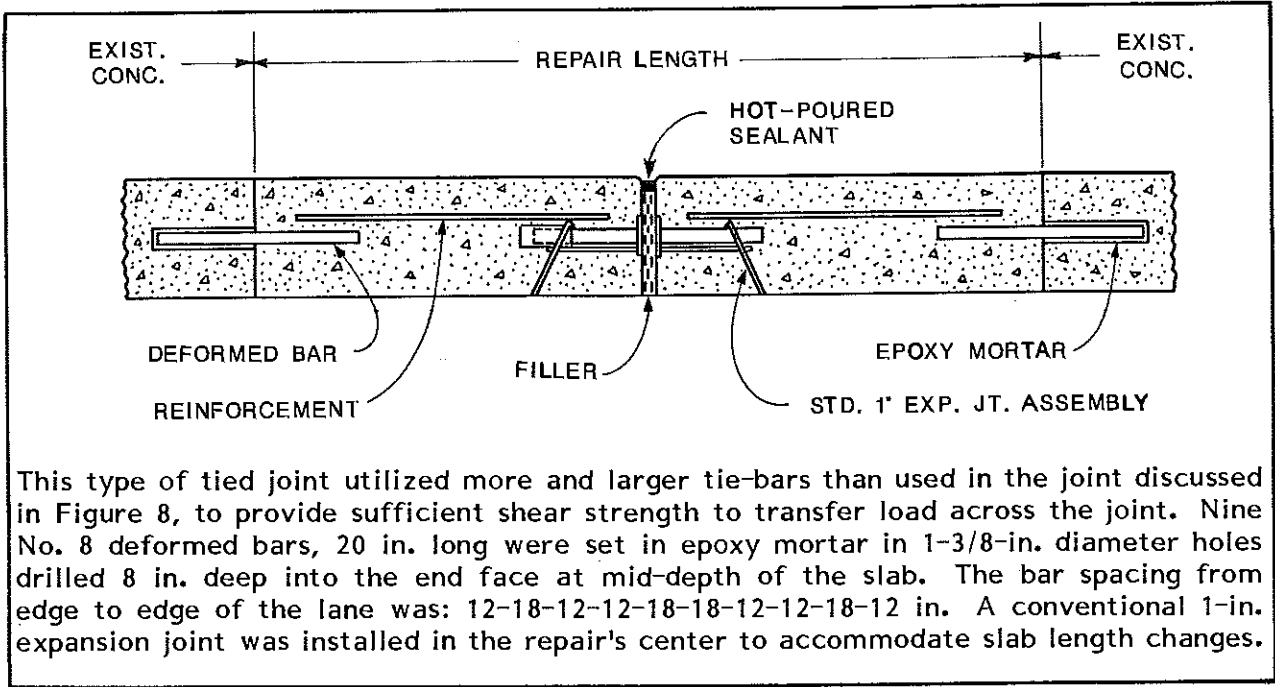

Straight cut tied end joints (expansion joint in center)

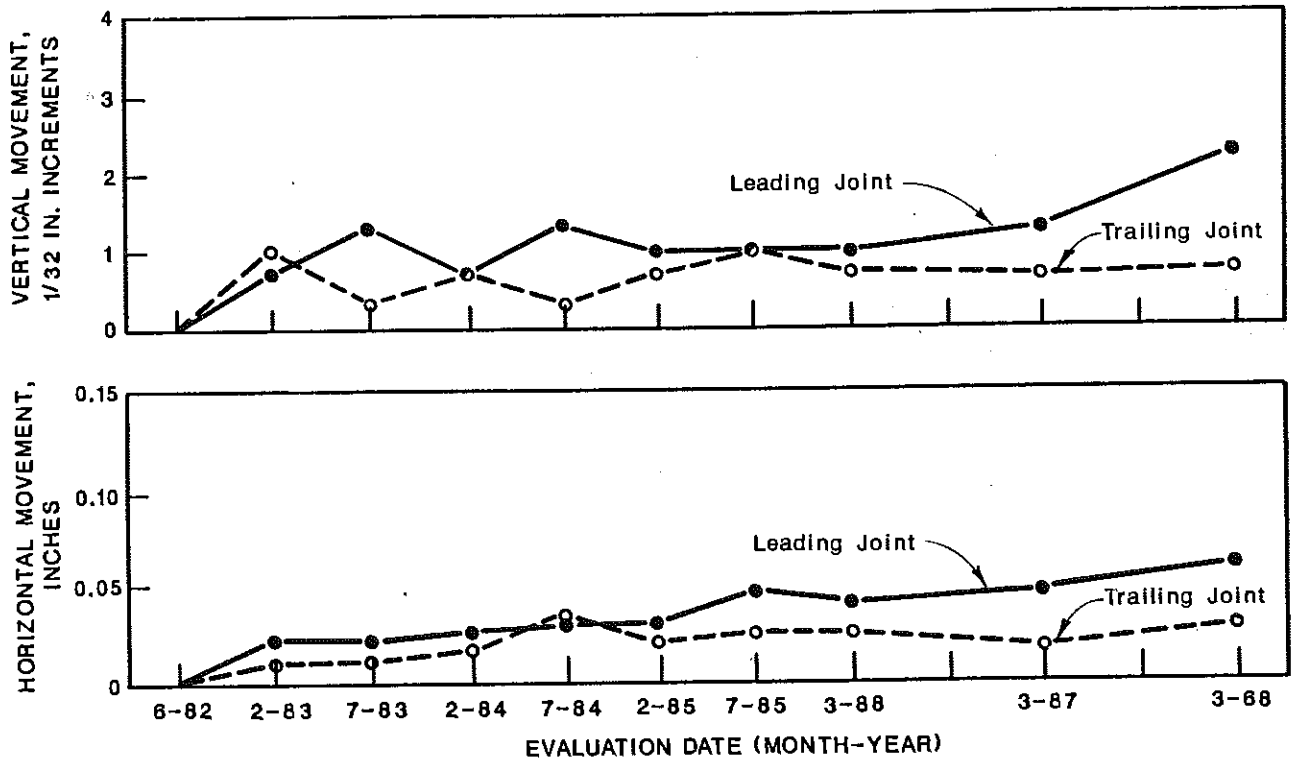
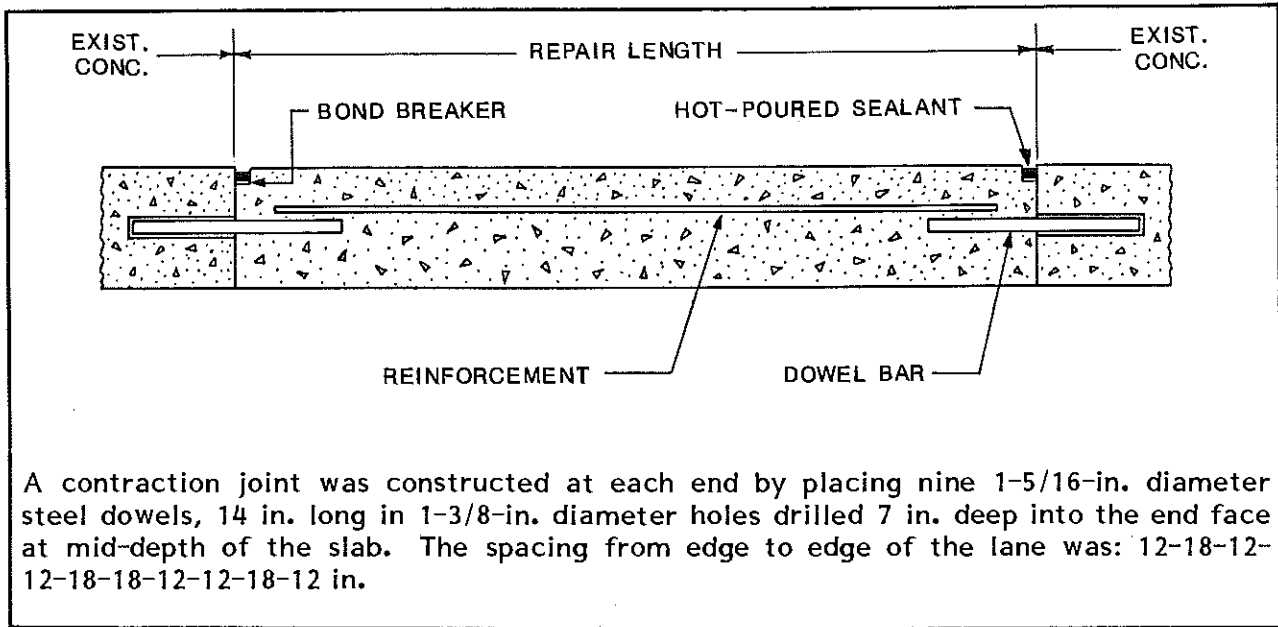

Figure 9. Joint design and average vertical and horizontal movements at straight-cut tied joints (stage 2 repairs on I 94, subjected to 1,800,000 ESALS).



Dowelled contraction joints

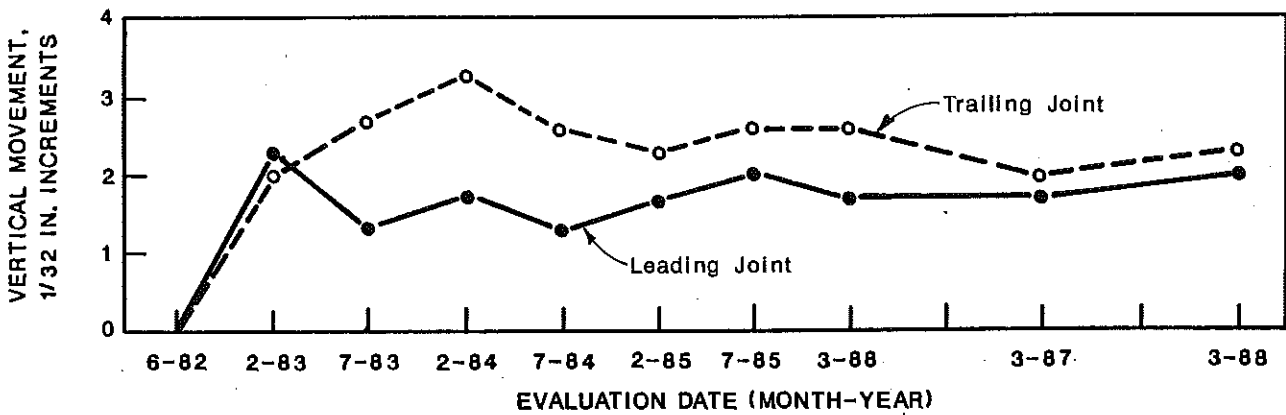
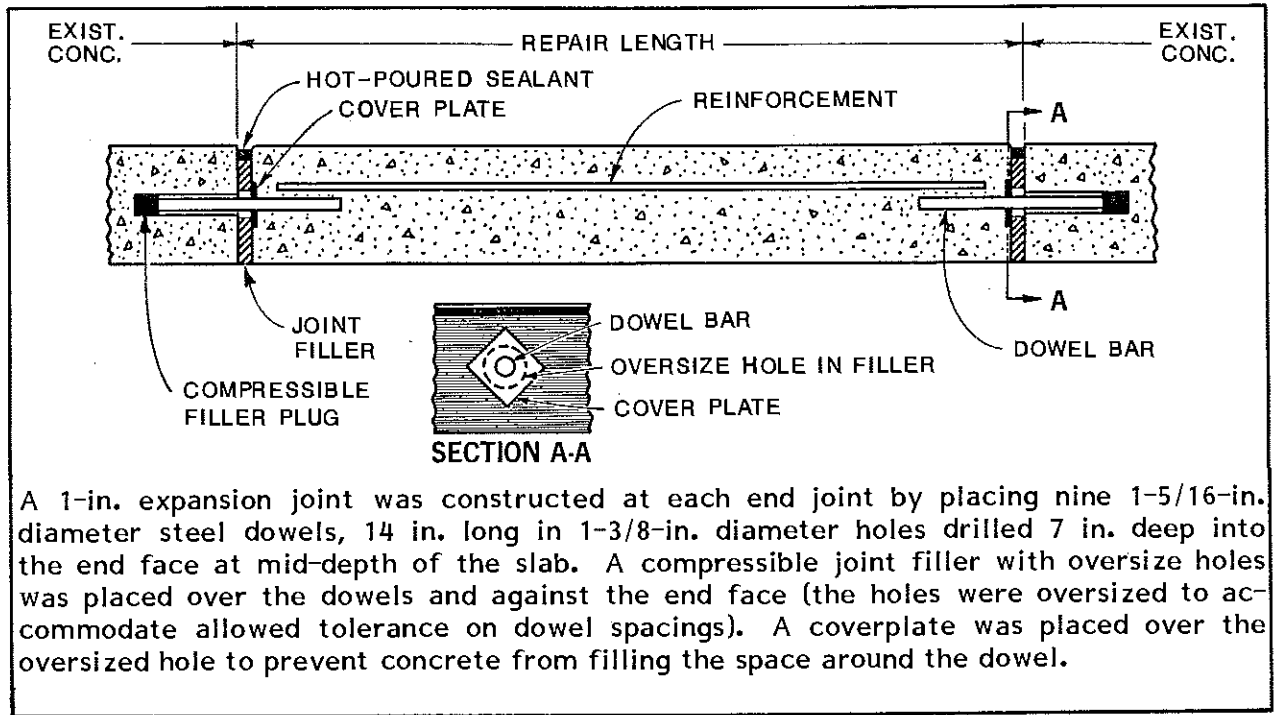

Figure 10. Joint design and average vertical movement at dowelled contraction joints (stage 2 repairs on I 94, subjected to 1,800,000 ESALS).



Dowelled expansion joints

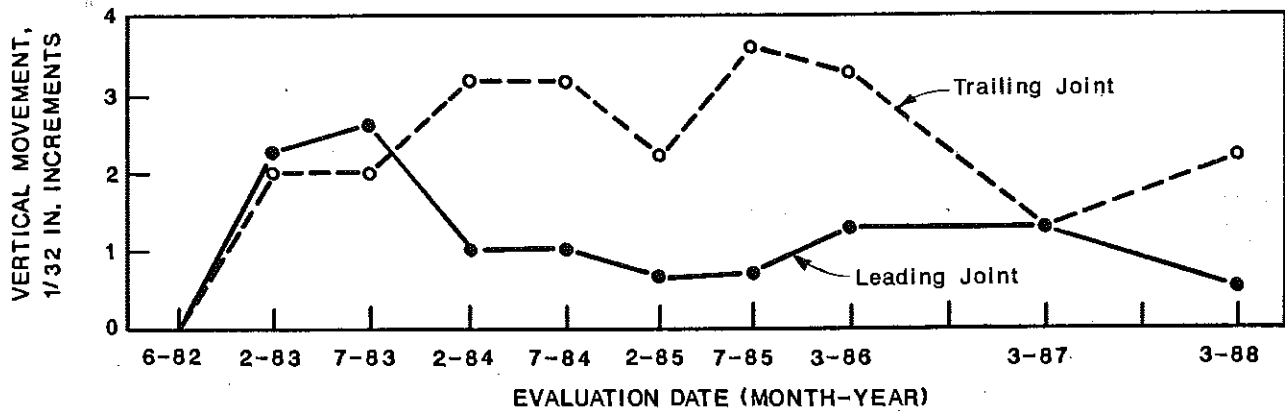
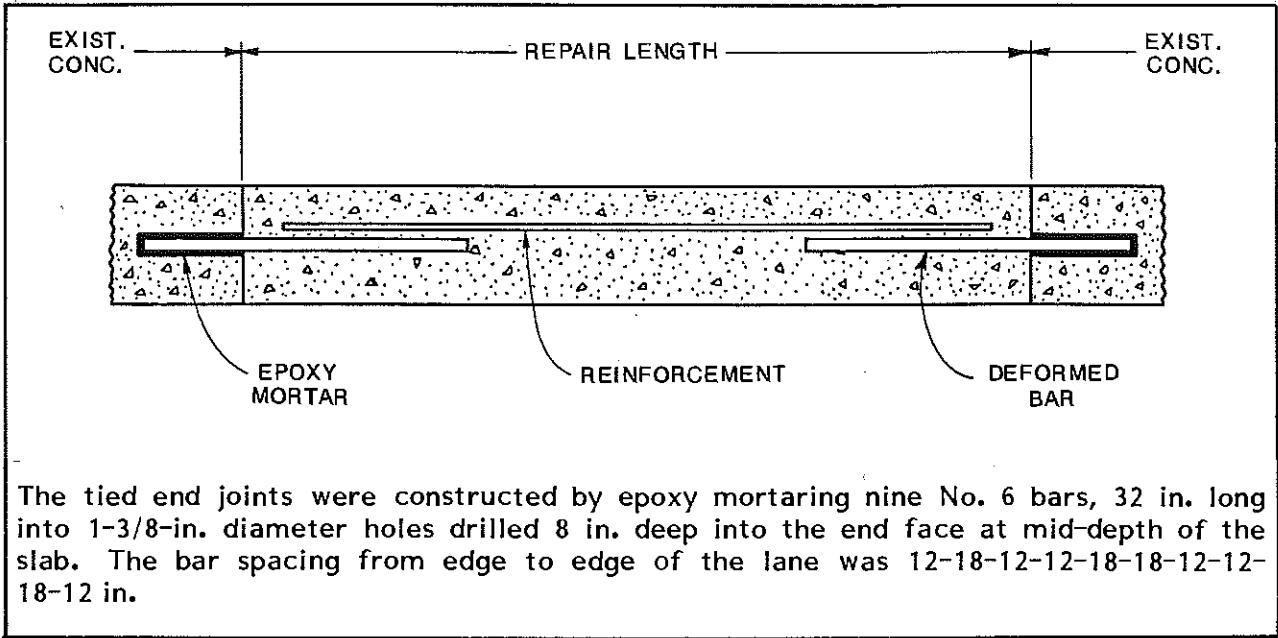

Figure 11. Joint design and average vertical movement at dowelled expansion joints (stage 2 repairs on I 94, subjected to 1,800,000 ESALS).



Tied end joints

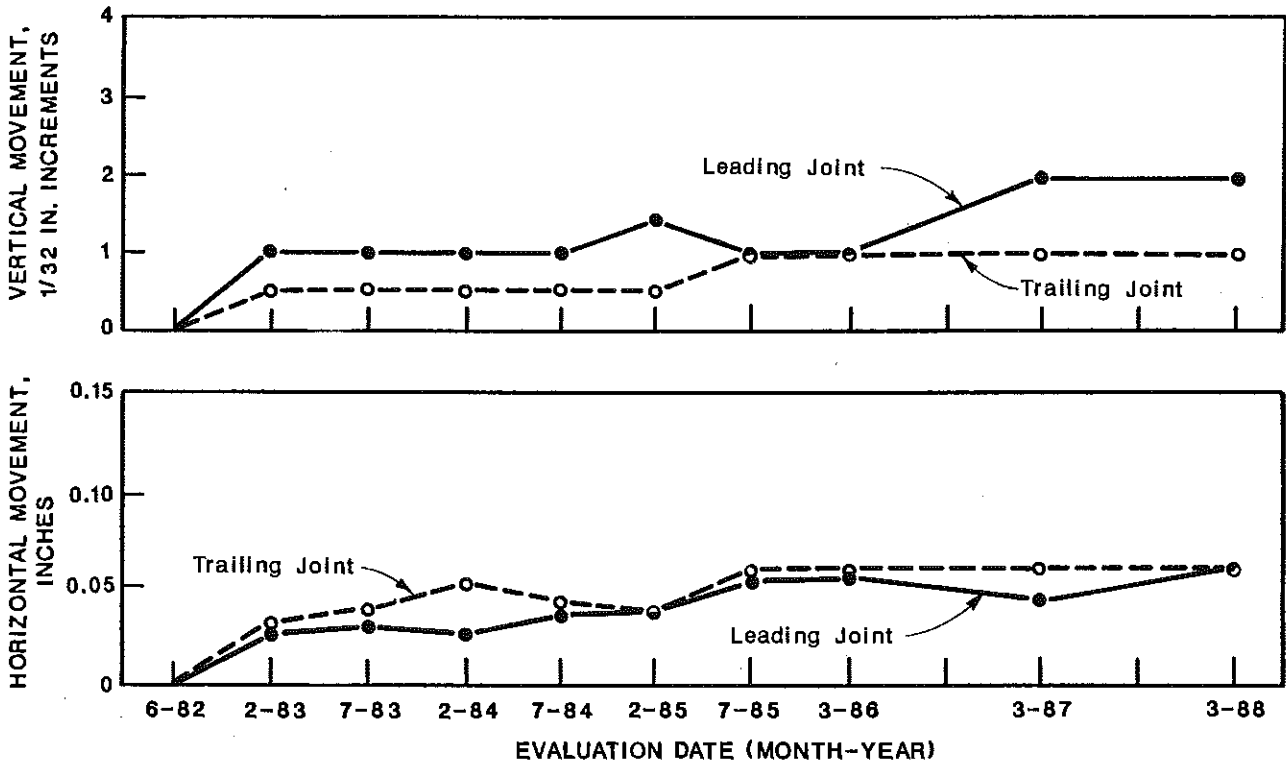
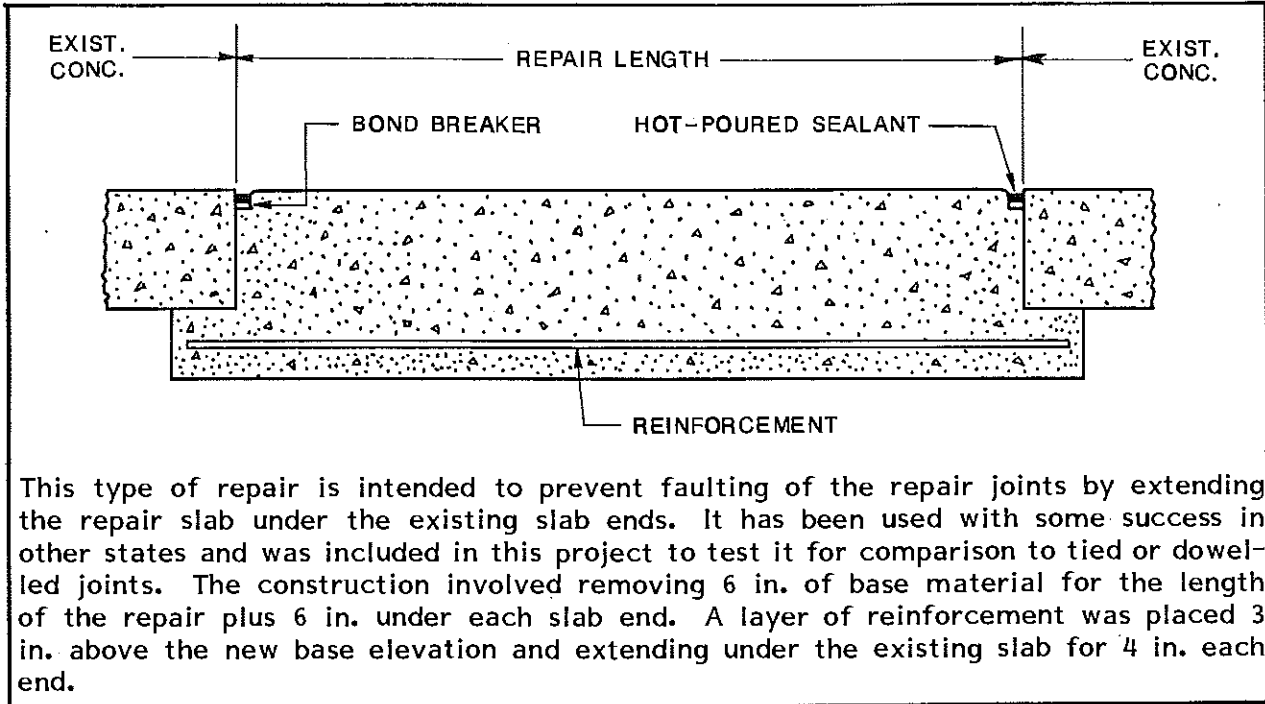

Figure 12. Joint design and average vertical and horizontal movement at tied joints (stage 2 repairs on I 94, subjected to 1,800,000 ESALS).



Inverted T-slab repair

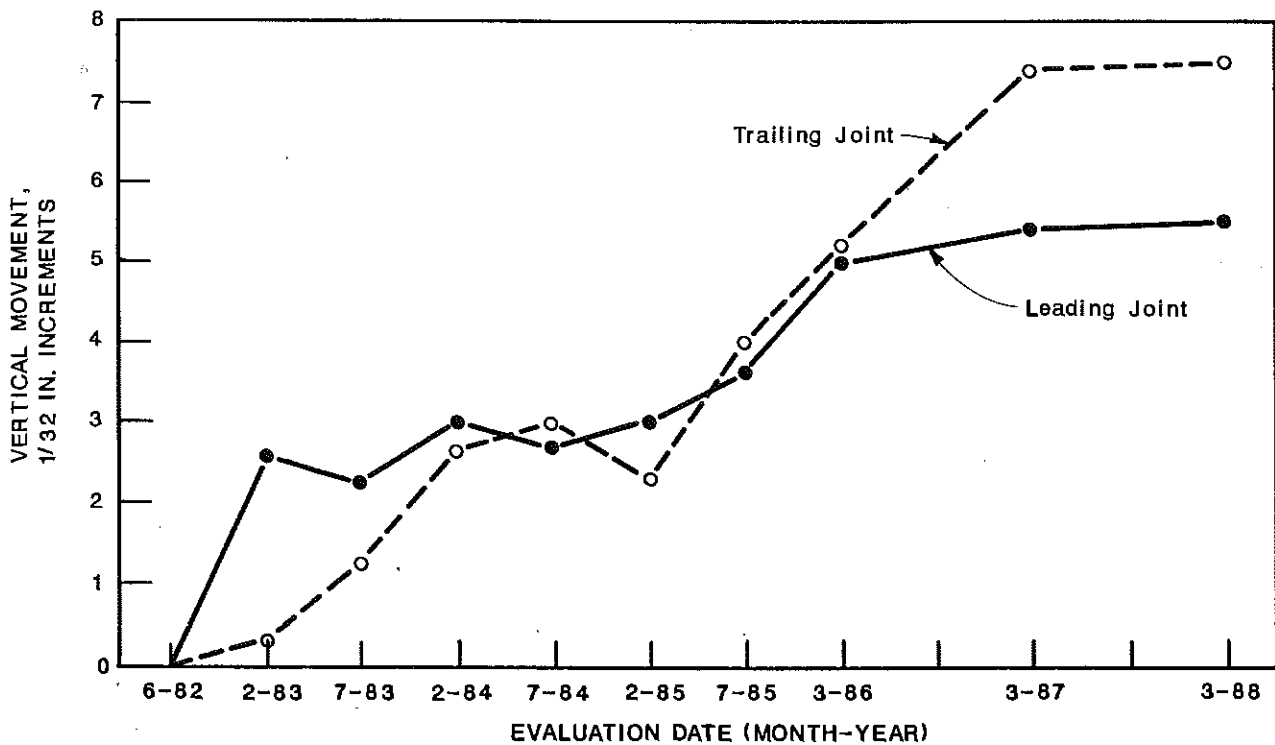

Figure 13. Joint design and average vertical movement at inverted T-slab joints (stage 2 repairs on I 94, subjected to 1,800,000 ESALS).

It is generally agreed among highway engineers that vertical offsets (faulting) at joints become objectionable when they approach or exceed 7/32 in. Based on this, the tied and dowelled repairs performed satisfactorily during their six-year service life, but the performance of the inverted T-slab was marginal.

Stage 3 Repairs

Concurrent with construction of the experimental repairs on I 94 in Calhoun County, contract work involving 2700 repairs was in progress on I 94 in Jackson County. The design of the Jackson County section of I 94 is identical to the design used in Calhoun County, and ranged in age from 23 to 29 years. The project was 14 miles long and in 1988 the eastern half was overlaid with a bituminous mat and the western portion has been scheduled for recycling in the near future. It is estimated that during the six-year period following the construction the repairs have been exposed to 3,500,000 18-Kip ESAL.

Of the 2700 repairs, 2100 utilized step-cut tied end joints with an expansion joint in the center and the remaining 600 had a dowelled contraction joint at the repair ends. Figure 14 shows sketches of the two repair types as well as describing the construction method and materials used.

The performance of the tied end joints has been disappointing, because of their inability to prevent movements. The opening of the joints beyond the width of the step-cut negated their ability to prevent faulting. Based on the measurement of instrumented joints, the number of failures has progressed with time. After one year, 4 percent of the repairs had failed and now after six years of service 72 percent have failed. In contrast, the dowelled contraction joints have all performed excellently by maintaining their smoothness.

An investigation by coring through the tie bar locations revealed that the cause of the tie bar failure was an insufficient amount of epoxy grout placed in the holes prior to inserting the bars. In a few cases the failures were caused by improper proportioning of the two epoxy components used in the grout mix, which resulted in its remaining in a semi-plastic state. Figure 15 shows cores with failed bars, a failed tied joint repair after six years of service, and a good performing six-year old contraction joint repair.

The performance of dowelled contraction joints and step-cut tied joints (with properly grouted bars) is shown graphically in Figure 16. As can be seen, the vertical offset at the dowelled joint has varied between 1/32 to slightly more than 1/16 in. throughout the performance period. Both the vertical and horizontal movements at the tied joints have been very small. The vertical offset has been less than 1/16 in. and the horizontal movements have never exceeded 0.04 in.

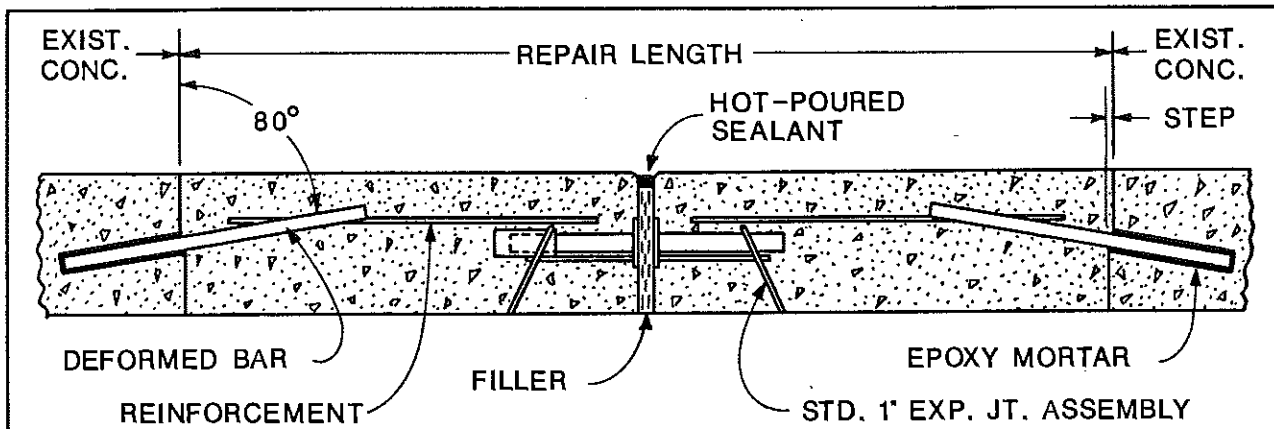

The end joints had a 1/4-in. wide sawed step at mid-depth (constructed by mounting two 18-in. blades next to a single 26-in. diameter blade). Seven No. 6 deformed bars, 20 in. long were set in epoxy mortar in 1-3/8-in. diameter holes, drilled 8 in. deep into the end face at mid-depth of the slab. The bar spacing was: 12-18-18-24-24-18-18-12 in. (the first and last bar were 12 in. from the lane edge). A conventional 1-in. expansion joint was installed in the repair's center to accommodate slab length changes.

Step-cut tied end joints (expansion joint in center)

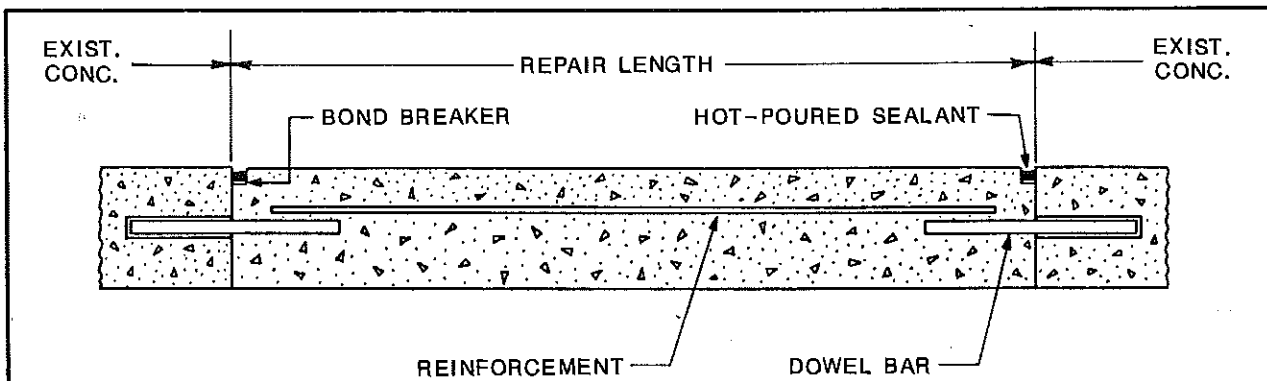

A contraction joint was constructed at each end joint by placing nine 1-5/16-in. diameter steel dowels, 15 in. long in 1-3/8-in. diameter holes drilled 7-1/2 in. deep into the end face at mid-depth of the slab. The spacing from edge to edge of the lane was: 12-18-12-12-18-18-12-12-18-12 in.

Dowelled contraction joints

Figure 14. Design of step-cut tied end joints with expansion joint in center (top) and dowelled contraction joints (bottom) used in constructing the stage 3 repairs on I 94 in Jackson County.



Figure 15. Failed tie bars caused by insufficient amount of grout around the bars (top), condition of repair with open and faulted tied joints after six years service (center), and condition of good performing six-year old dowelled repair (bottom); stage 3 repairs on I 94 in Jackson County, subjected to 3,500,000 ESALS.

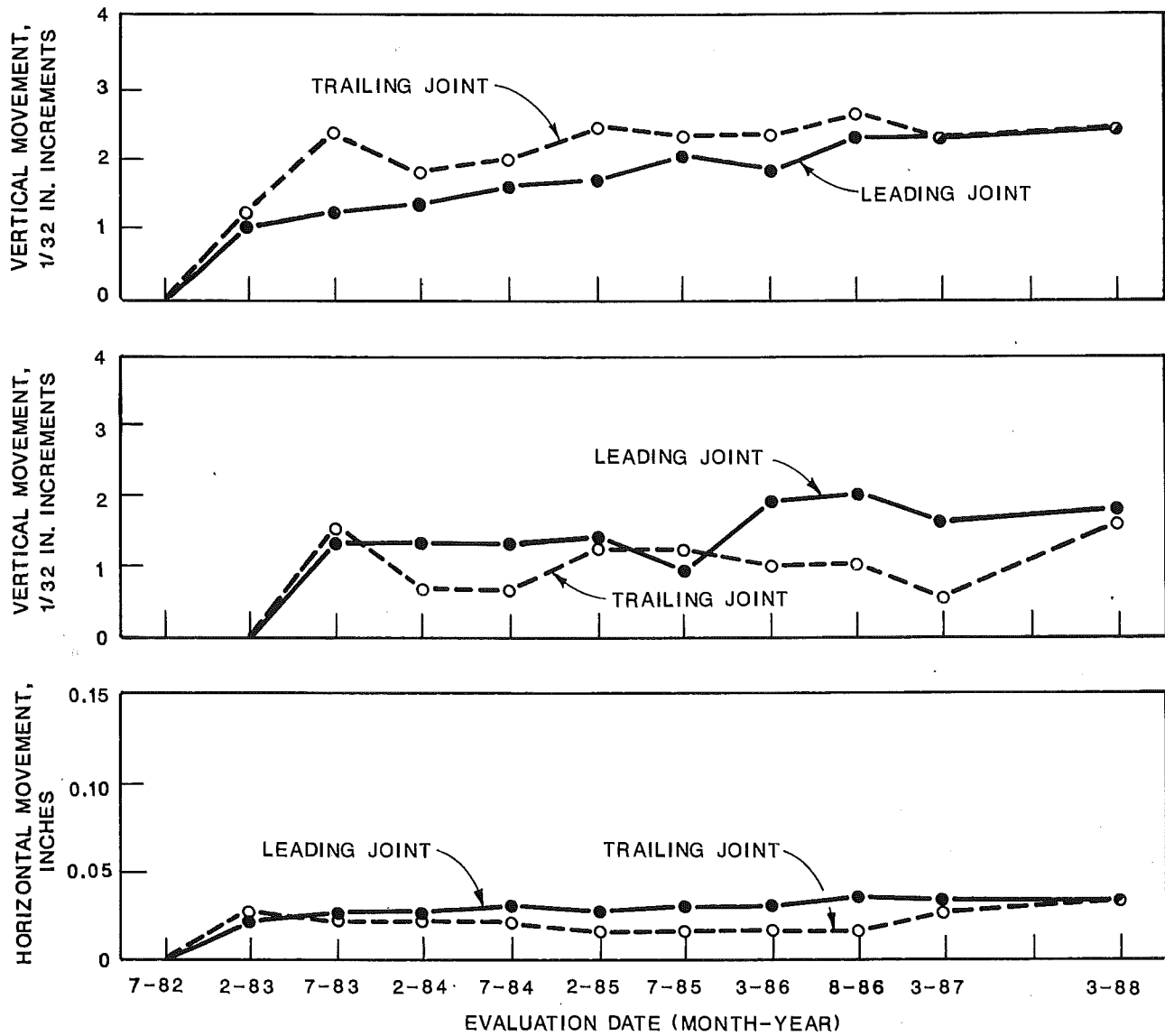

Figure 16. Average vertical movements at dowelled joints (top), at tied joints (middle), and horizontal movement at tied joints (bottom) on stage 3 repairs (I 94 in Jackson County), subjected to 3,500,000 ESALS.

DISCUSSION

Although a large percentage of the step-cut tied joints have failed since they were installed nearly seven years ago, the experiment demonstrated that tied joints can function satisfactorily for several years on heavy truck routes if properly installed. As previously discussed, the failure of the tie bars was found to be caused by the grout not curing because of faulty measurements of the epoxy ingredients or caused by an insufficient amount of grout being placed in the drilled holes.

Advances in the grouting technology during the past few years practically eliminate the problems experienced on the I 94 contract project. Equipment is now available that dispenses the grout components accurately and mixes them in a special nozzle. The nozzle is of sufficient length so the grout can be deposited in the back of the horizontal holes and it is possible to calibrate the equipment so the exact amount of grout is placed in each hole. Thus, when the bar is inserted, a good bond along the entire length of the embedment is assured.

This relatively new equipment has been used with success in grouting tie bars for pavement widening on several projects. It was also used on a repair project to construct a tied joint at one repair end and to grout the dowels in place at the other end. The tied joint consisted of ten No. 10 deformed bars grouted into 1-3/8-in. holes and the dowelled joint had ten 1-1/4-in. dowels grouted into the existing concrete. The protruding dowel end was coated to allow sliding in the new repair concrete. The use of such tied repair joints results in a smooth and noise-free joint and grouting the dowels in-place ensures high load transfer efficiency across the joint.

The subject experiment also verified that joints with loose fitting dowels, that had performed well under light commercial traffic, performed equally well on one of our heaviest truck routes. The dowels are 1-5/16 in. in diameter and the drilled holes are 1-3/8 in. in diameter giving a 1/32-in. clearance around the dowel. Our experience with dowelled joints having similar loose fitting dowels began in 1972 when a few experimentally dowelled repairs were constructed. Based on the performance of these early repairs and on the performance of the 600 dowelled repairs constructed on I 94 the Department approved the general use of dowelled repairs in 1983.

Since then several thousand repairs have been constructed using dowelled joints. Their performance has been monitored by measuring the vertical movement at the repair joints. Forty repairs were monitored on I 75 east of Pontiac and on US 23 north of M 59. Both of these routes carry heavy truck volumes (1600 trucks per day). On I 75 Business Loop in Pontiac with a daily truck volume of 600, 20 repairs were monitored. The percent of joints with the following amounts of faulting, measured in increments of 1/16 in., at the leading and trailing joints after five years service, is shown on the following table:

Faulting (1/16 in. increments) vs. Percentage of Joints

Route	Leading Joint					Trailing Joint				
	0	1	2	3	4	0	1	2	3	4
I 75	32	50	15	3	0	5	38	35	17	5
US 23	40	45	13	2	0	0	10	43	42	5
I 75 Bus.	28	56	11	5	0	39	44	17	0	0

As can be seen, the majority of the faulting measured 3/16 in. or less with only 5 percent of the readings being 1/4 in. on both I 75 and US 23.

The most important factor in obtaining good performing repairs is the base. It must be left undisturbed so that it has the same support value as the existing pavement. Care must be exercised to ensure the dowel holes are drilled to the proper size without excessive spalling at the joint faces, and, of course, it is imperative that the concrete be finished properly to meet the elevation of the existing pavement slab. Finally, the aggregate used in the concrete into which the loose dowels are inserted must be durable and have good abrasion characteristics, otherwise the dowels may wear the holes oblong resulting in excessive faulting.

CONCLUSIONS

Hand proportioning, mixing, and dispensing of the grout for tie bar installations is not suitable for a large scale project.

When properly constructed, repairs using loose fitting dowelled joints will maintain their smoothness for several years.

RECOMMENDATIONS

It is recommended that the use of loose fitting dowels be continued when repairing pavements 15 years or older. On pavements less than 15 years old and on pavements constructed with concrete containing aggregate with low abrasion resistance the use of injected and premeasured epoxy grout is recommended for installing the dowels at repairs.

APPENDIX

PHOTOGRAPHIC SEQUENCE OF
CONSTRUCTION OPERATIONS

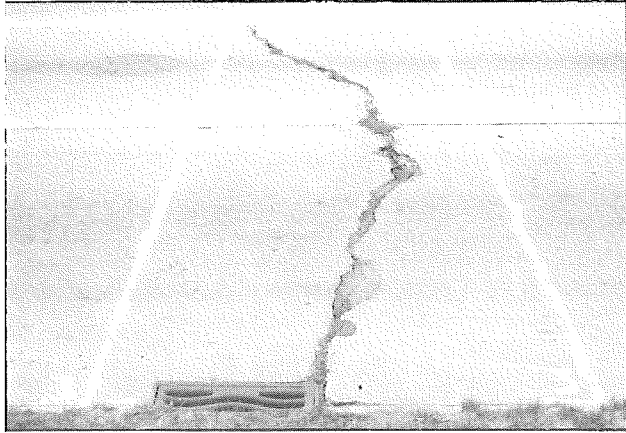

◀ Figure 1b. Limits of repair marked on pavement either by painting or by snapping a chalk line.

Figure 2b. Transverse end limits are sawed full-depth using a 65 hp saw equipped with a 26-in. diameter diamond blade. ▶

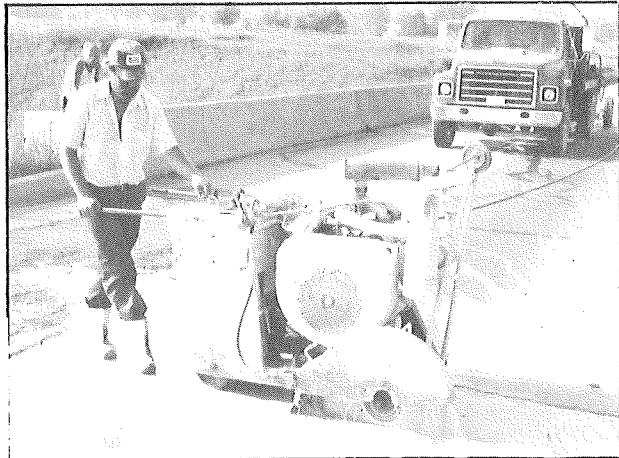

◀ Figure 3b. The longitudinal joint is also sawed full-depth.

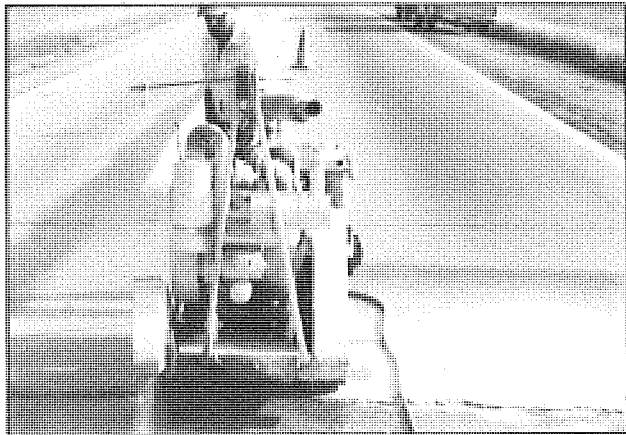
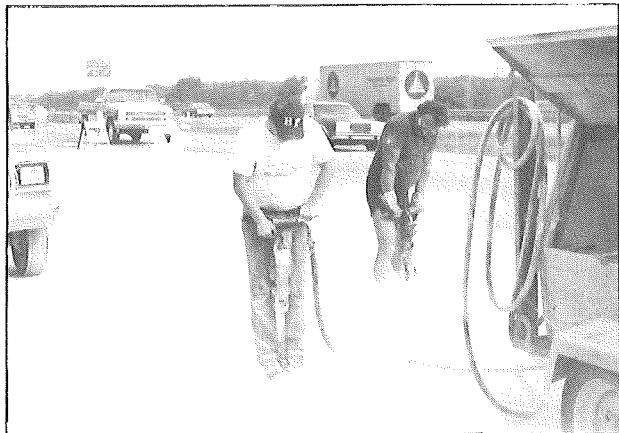

Figure 4b. Holes are drilled through the slab so that lift pins can be inserted. ▶



◀ Figure 5b. Lift pin holes should be located in sound concrete within the repair area. Note double saw cuts at right end limit.



Figure 6b. The concrete between the double saw cuts has been removed to relieve compression in the slab. ▶

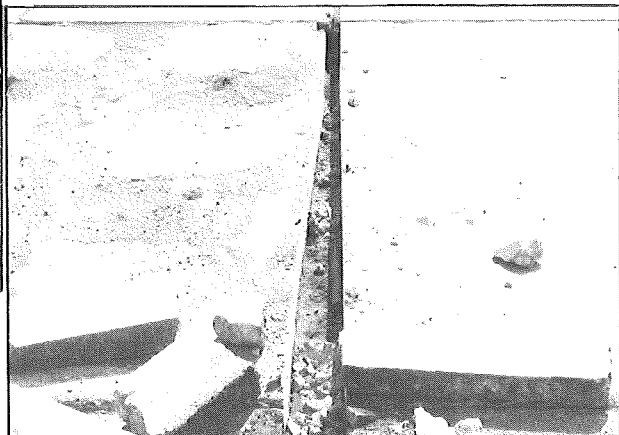



◀ Figure 7b. Installing lift pins and attaching chains to front-end loader.



Figure 8b. The distressed concrete area is lifted out without disturbing the base. ▶

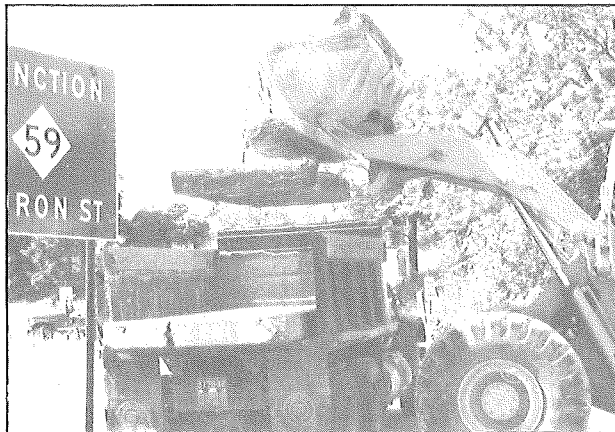

◀ Figure 9b. The broken concrete pieces are loaded on a truck and transported to disposal site.

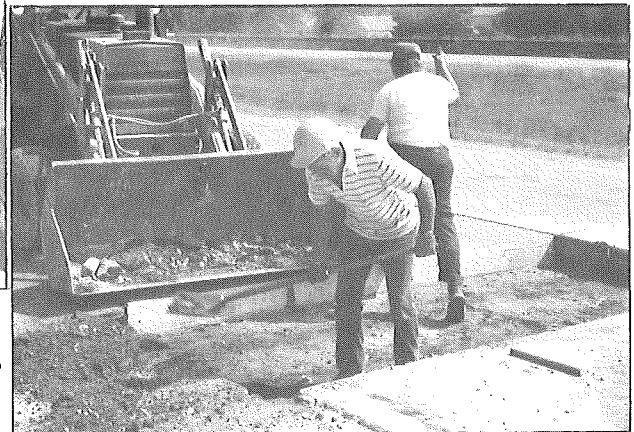
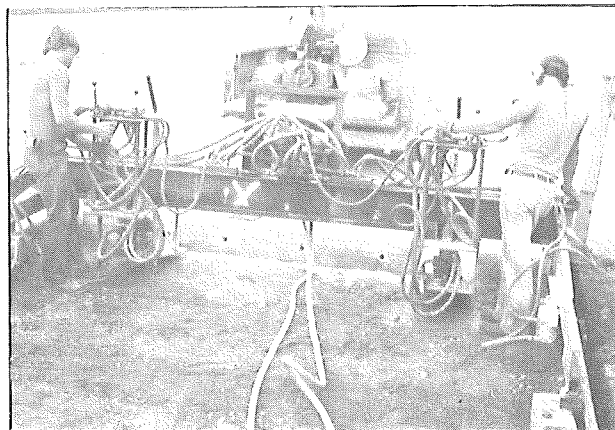

Figure 10b. Final clean-out of the area must be done by hand tools to prevent base damage. ▶



◀ Figure 11b. Holes for dowels (1-3/8-in. diam) are machine-drilled. Hand-held drills are not permitted.



Figure 12b. Dowel holes are cleaned by using compressed air. ▶

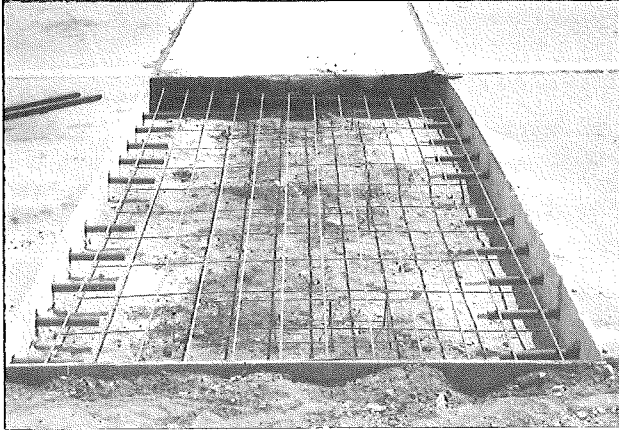

Figure 14b. To ensure that the holes in expansion joint filler boards fit over the dowels, the holes are marked on the filler using pointed locating pins. Holes sawed by use of a standard hole saw.

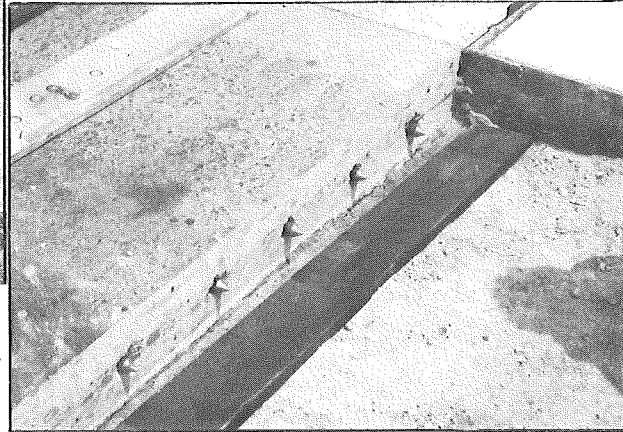

Figure 13b. Contraction joint with forms, dowels, and reinforcement in place.

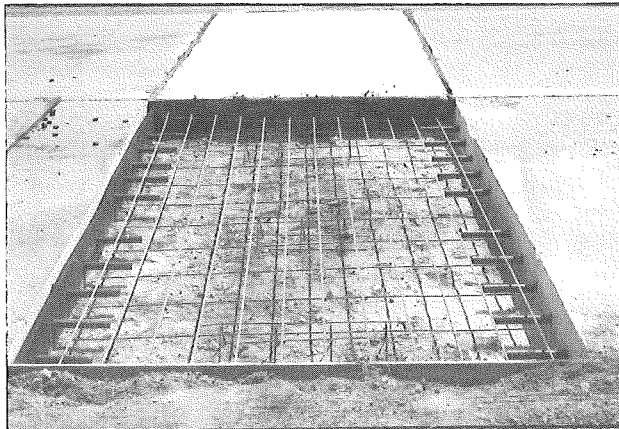

Figure 15b. Expansion joint repair. Filler and groove forming strip at left side.

Figure 16b. The replacement concrete consists of a 9-sack mix with flake calcium chloride added at the job site just prior to pouring. The use of calcium chloride allows the concrete to attain required strength (300 psi, flexural) in four to eight hours.



Figure 17b. The replacement concrete must meet the specified slump requirement to ensure that the strength can be obtained within the specified time limit.

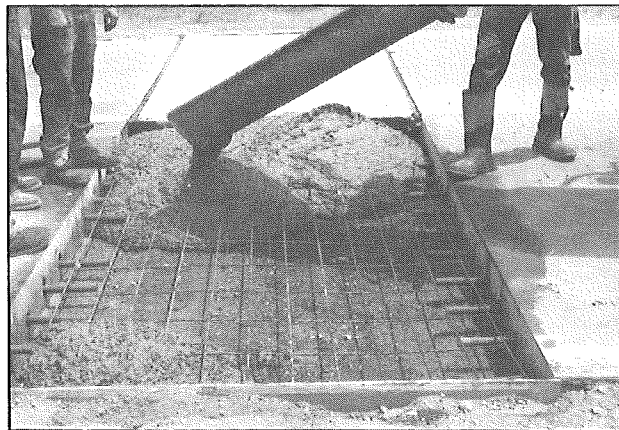

Figure 18b. Once the concrete is cast, groove forming wood strips are inserted in the concrete.





◀ Figure 19b. Consolidation of the concrete must be done by use of immersion-type vibrators.

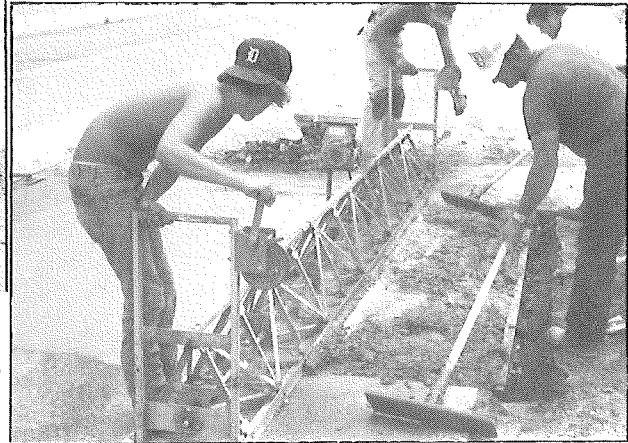

Figure 20b. The concrete must be struck-off using a vibrating screed. At least two passes must be made. ▶



◀ Figure 21b. The surface of the concrete is finished by hand floating.



Figure 22b. The limits of the repair are edged. ▶

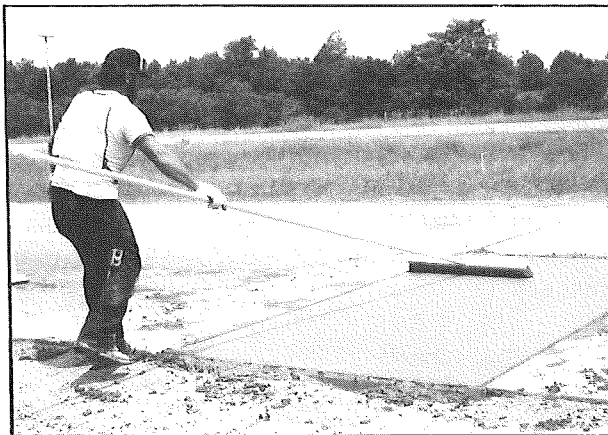

◀ Figure 23b. The surface is textured by using a coarse broom.



Figure 24b. Prior to the concrete gaining its initial set, the groove forming strips are removed. ▶



Figure 26b. The joint grooves are cleaned by sand blasting and compressed air prior to sealing.



Figure 28b. A hot-poured rubber-asphalt sealant is installed in the joint grooves.

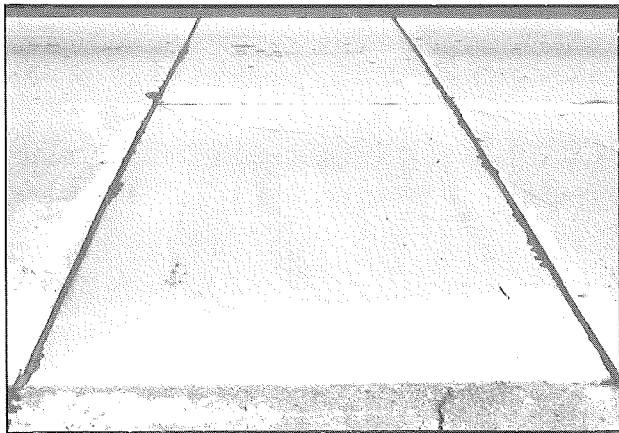

Figure 30b. Completed portion of 14-mile long repair project. A total of 2,700 repairs were made.

Figure 25b. A membrane curing compound is applied to the surface of the repair. When the temperature is below 65 F, curing blankets are used.



Figure 27b. A tape is installed in the bottom of contraction joint grooves to prevent the sealant from bonding to the bottom of the groove.



Figure 29b. A completed joint repair slab.

