

TE
228
.N44
1972
c.2

FINAL REPORT
THREE EXPERIMENTS WITH
TRANSVERSE PAVEMENT STRIPES
AND RUMBLE BARS

TSD-RD-216-72

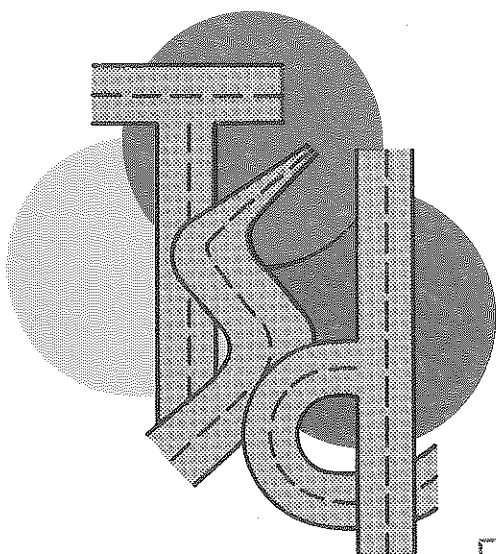

**TRAFFIC and
SAFETY
DIVISION**

LIBRARY
michigan department of
state highways
LANSING

**DEPARTMENT OF STATE HIGHWAYS
STATE OF MICHIGAN**

5-9519
65-9416

MICHIGAN STATE HIGHWAY COMMISSION

Charles H. HewittChairman
E. V. Erickson.Vice-Chairman
Claude J. TobinMember
Peter B. FletcherMember

FINAL REPORT

THREE EXPERIMENTS WITH
TRANSVERSE PAVEMENT STRIPES
AND RUMBLE BARS

TSD-RD-216-72

By

Nejad Enustun

LIBRARY
michigan department of
state highways
LANSING

MICHIGAN DEPARTMENT OF STATE HIGHWAYS

J. P. Woodford Deputy Director - Chief Engineer
J. G. Hautala. Chief, Bureau of Operations
H. H. Cooper Engineer of Traffic and Safety
P. H. DeCamp Traffic Research and Development
Engineer
R. E. Addy Supervisor, Research Studies Unit
Nejad Enustun. Study Engineer

Department of State Highways
State Highways Building- P. O. Drawer K
Lansing, Michigan 48904

October 1972

SUMMARY

For the purpose of testing a traffic device that might cause visual sensation to drivers and induce them to reduce speed at a highway construction area, a study was initiated to measure the effectiveness of transverse plastic pavement stripes with gradually decreased spacing. An ABS plastic rumble bar was then tested in conjunction with yellow painted stripes at a second test site (a rural sharp curve), and at a third test location (a temporary urban freeway ending in the shape of a trumpet interchange), an experiment was conducted using polyvinyl chloride rumble bars.

In all three tests, the stripes and rumble bars were spaced to appear at a constant repetition frequency to a decelerating vehicle. This was based on a vehicle approaching with a constant deceleration rate of 3 ft./sec^2 . Conversely, this spacing resulted in an appearance or rumble of gradually increasing rate to a vehicle that did not reduce speed, thus giving the illusion of acceleration of the vehicle's speed.

In the absence of other readily measurable outputs, speed change was selected as an acceptable indication of the effectiveness of these devices in alerting the driver to an impending danger or maneuvering requirement. In all cases speed reduction was the desired maneuver after the attention-getter, and thus was chosen to be the logical parameter for this research.

Colored stripes alone resulted in a numerically small reduction in average approach speeds. This has been attributed to the prevalence of drivers familiar with the test and the area. It is concluded, however, that the stripes are effective in alerting drivers, which is their purpose.

Both kinds of rumble bars caused larger reductions in average speeds than the colored stripes. The ABS bars generated criticism from the public because of the rough ride. Furthermore, they caused a large deviation from the mean speed which is considered a disadvantage because of the increase in accident potential.

The reduction in mean speed obtained by all of the tested devices diminished with the lapse of time. This is due to familiarization of most drivers with the particular location; however, the device is still effective for the non-vigilant driver.

The polyvinyl chloride rumble bars provided tolerable rumble as well as visual color contrast over the light-colored concrete pavement. There was a change in the skewness index of the speed distribution from non-normal to normal with these bars, and this provided an additional safety element.

In general, paint stripes are applicable for situations where a highway hazard cannot be readily eliminated. Low-profile rumble bars are recommended for use in construction areas as well as at other locations that require maximum driver-awareness, provided

that special precaution is taken not to damage them during winter maintenance.

CONTENTS

	<u>Page</u>
SUMMARY	1
LIST OF TABLES.	5
LIST OF FIGURES	6
INTRODUCTION AND OBJECTIVES	7
BACKGROUND INFORMATION.	9
APPLIED PHYSICS AND STATISTICS.	11
DESCRIPTION OF THE EXPERIMENTS.	14
Transverse Pavement Stripes on I-75.	14
Pavement Stripes and Rumble Bars on M-106.	29
Rumble Bars on I-496	41
CONCLUSIONS AND RECOMMENDATIONS	50
BIBLIOGRAPHY.	53

LIST OF TABLES

	<u>Page</u>
Table 1: I-75 Construction Area: Average Speeds on all Lanes by Radar	23
Table 2: I-75 Construction Area near 14 Mile Road: Average Speeds on Right Lanes by Loop Detectors	23
Table 3: I-75 Construction Area: Statistical Analysis of Speed Distribution on All Lanes	27
Table 4: I-75 Construction Area: Statistical Analysis of Speed Distributions on Right Lanes During Phase 3.	27
Table 5: M-106 Near Gregory: Speed Analysis of Vehicles Passing Over the Test Zone	40
Table 6: I-496 West of Lansing: Speed Analysis of Vehicles Passing Over the Test Zone.	47

LIST OF FIGURES

	<u>Page</u>
Fig. 1: Locations of Test Sites	15
Fig. 2: Transverse Pavement Stripes on I-75	16
Fig. 3: Side View of Transverse Stripes on I-75	18
Fig. 4: General Appearance of Transverse Stripes on I-75	18
Fig. 5: Induction Loop Taped onto Pavement.	20
Fig. 6: Electric Generator and Vehicle Detectors.	20
Fig. 7: Electronic Counter with Time Base, Coupled to Tape Printer	21
Fig. 8: Effect of Pavement Stripes on Speed Distribution on I-75.	24
Fig. 9: Plastic Stripes after Five Weeks under Traffic	29
Fig. 10: Transverse Pavement Stripes and Rumble Bars on M-106	31
Fig. 11: Paint Stripes on M-106.	33
Fig. 12: ABS Plastic Rumble Bar.	33
Fig. 13: Rumble Bars and Paint Stripes on M-106.	34
Fig. 14: Speed Drop of Individual Vehicles Between 1st and 24th Stripes on M-106	36
Fig. 15: Speed Distribution of Vehicles Passing Over the Test Zone on M-106.	38
Fig. 16: Rumble Bar Installation on I-496.	42
Fig. 17: Location of I-496 Rumble Area	44
Fig. 18: Driver's Eye View of Rumble Bars on I-496	45
Fig. 19: Side View of Rumble Bars on I-496	45
Fig. 20: Speed Distribution of Vehicles Passing Over the Test Zone on I-496	48

INTRODUCTION AND OBJECTIVES

Sustained highway driving, especially on freeways, is known to affect drivers adversely, making it difficult for them to judge safe speeds when the freeway ends or when any condition on a section of the freeway does not permit maintaining normal speed.

Spots where safe speeds are considerably below the normal operating speed are usually signed with advisory or regulatory notices. However, most drivers prefer to adjust their speed by visual perception of the conditions or by the kinetic forces which they sense through the behavior of the vehicle. Numerical speed signs have little effectiveness upon these drivers, and some aid other than numerical speed signs might help them to be more aware of their excessive rate of travel.

Transverse lines on the pavement is one device that provides an easily-recognizable reference for gauging speed. A gradual decrease in the spacing of these lines may subconsciously be effective in influencing the driver to slow down.

The original objective of this project was to investigate by a study of driver behavior the effectiveness of transverse pavement markings in alerting the driver to reduce his speed. Later, it was decided to also test the effect of rumble bars on traffic speed. The term "rumble bar" rather than the more common "rumble strip" is used throughout this report to distinguish these temporary devices from the formed-in-place types of rumble strips

LIBRARY
michigan department of
state highways
LANSING

of more permanent nature such as stone chips embedded in epoxy,
or bituminous mats.

BACKGROUND INFORMATION

A short news item appeared in early 1960's in the British periodical "Traffic Engineering and Control" describing transverse white pavement lines of successively diminishing spacing which were used in a Swiss city in advance of a stopping situation. The result was reported to be successful.

In 1965 the Michigan Department of State Highways Traffic Division experimented with white 18" wide transverse paint lines on the pavement and having spacings decreasing from 275 to 100 feet. The westbound approach to Euclid Avenue and the eastbound approach to Crystal Avenue on BL-94 in Benton Township, Berrien County were the test sites. The purpose was to induce deceleration of vehicles approaching the two intersections and reduce the high accident record attributed to excessive approach speeds. Before-and-after speed checks indicated no reduction in average speeds (1)*. The 18-inch wide stripes were later considered to be too narrow and the spacing too large for proper influence on the drivers' visual sense, and these were concluded to be the reasons for the lack of speed reduction.

The New Jersey Turnpike Authority had provided information about their experience with yellow transverse paint stripes at approaches to toll gates. They indicated that striping had reduced accidents by 55 percent in spite of an increased volume of four percent. The spacing of stripes varied to correspond

*See BIBLIOGRAPHY at the end of this report for this and other numbered references.

to a distance traveled in one second, based on approach speed and normal deceleration. Stripe width was four feet for the first few and three feet for the remainder.

Many states have experimented with some type of pavement rumble strip or rumble area.* In most cases these devices have been of a permanent nature, made of bituminous mixes or epoxy resins in combination with crushed stone or other materials. Very little information exists on the use of temporary rumble bars that could be easily removed after use at road construction areas.

*See BIBLIOGRAPHY items 7 through 15.

APPLIED PHYSICS AND STATISTICS

The hypothesis to be tested in this study was that if a driver approaching a dangerous location failed to reduce his speed, he would see the transverse road stripes at an increasing rate per unit of time, and this illusion of acceleration would cause him to reduce his real rate of travel.

In calculating the total length of the roadway to be striped, it was assumed that the vehicle would decelerate at a very comfortable rate of three feet per second per second (which can normally be attained without braking), and stripes would be installed from the point upstream where deceleration starts to the point downstream where deceleration ends.

The basic relation between average acceleration (a), operating speed (V_1) at the upstream location, restricted speed (V_2) before the hazard area, and the distance (D) traveled before slowing down to the second speed is:

$$D = \frac{V_1^2 - V_2^2}{2a}$$

As an example, if it is desired to reduce the speed from 60 to 30 m.p.h., converting these speeds into feet per second, the stretch of road to be striped would be

$$D = \frac{(88)^2 - (44)^2}{2 \times 3} = 968 \text{ ft.}$$

The spacing (S) between stripes would depend on the rate of desired appearance per second (N) and the travel speed (V), and

$$S = \frac{V}{N}$$

For the example given above, if two flashes, or appearances, per second are desired, maximum spacing at the upstream end would be:

$$S = \frac{88}{2} = 44 \text{ ft.},$$

and the minimum spacing at the downstream end would be:

$$S = \frac{44}{2} = 22 \text{ ft.}$$

For practical purposes, the variable spacing between the two ends would be effected by a method of trial and error.

The minimum number of vehicles to be sampled for determining spot speeds depends on the accuracy sought and the standard deviation of the speed distribution at a particular spot. A report by the University of Illinois contains the basic information for this purpose (2).

A statistical accuracy of two miles per hour was deemed sufficient since the field use of a radar speed meter under the circumstances of these experiments does not allow more accuracy than this tolerance. Using the chart shown in Figure 2 of the above-mentioned report for the 50 percentile speed, a statistical confidence level of 95 percent and the largest figure of 10 for standard deviation, it was determined that 100 samples would

be satisfactory. During some additional speed studies using pavement loop detectors and automatic recording instruments, as will be explained later, sample sizes used were substantially larger than the basic figure of 100.

DESCRIPTION OF THE EXPERIMENTS

Transverse Pavement Stripes on I-75

In 1969 two loop ramps were added to the Interstate-75 Freeway interchange at 14 Mile Road between the cities of Madison Heights and Troy within the Detroit metropolitan area. Normal freeway speed was 70 m.p.h., and safe speed through the construction area was 45. The construction area was used as the test site for this experiment.

It was desired that the material to be used for pavement striping should be easily removable at the end of the construction activities. Therefore, plastic pavement-marking sheet 0.095 inch thick and yellow in color was used. The material is normally used for longitudinal pavement-marking such as center lines. It has an adhesive backing protected by a paper tissue. A surface primer also was applied to the concrete pavement during installation.

Transverse pavement striping, in conjunction with usual warning signs and other devices, was used on the southbound pavement. The northbound pavement was not striped and was used for comparison. The gradients on the northbound and southbound roadways are almost equal. The stripes were approximately four feet wide and 36 feet long, and crossed three freeway lanes at right angles. Figure 2 shows their location in relation to the existing traffic control signs. Three parallel plastic sheets 12 inches wide

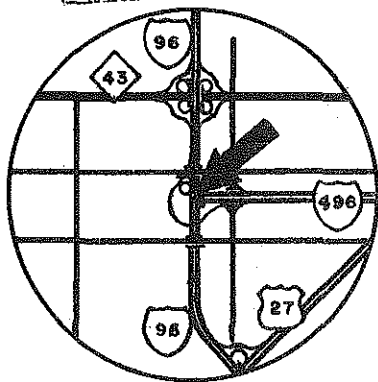
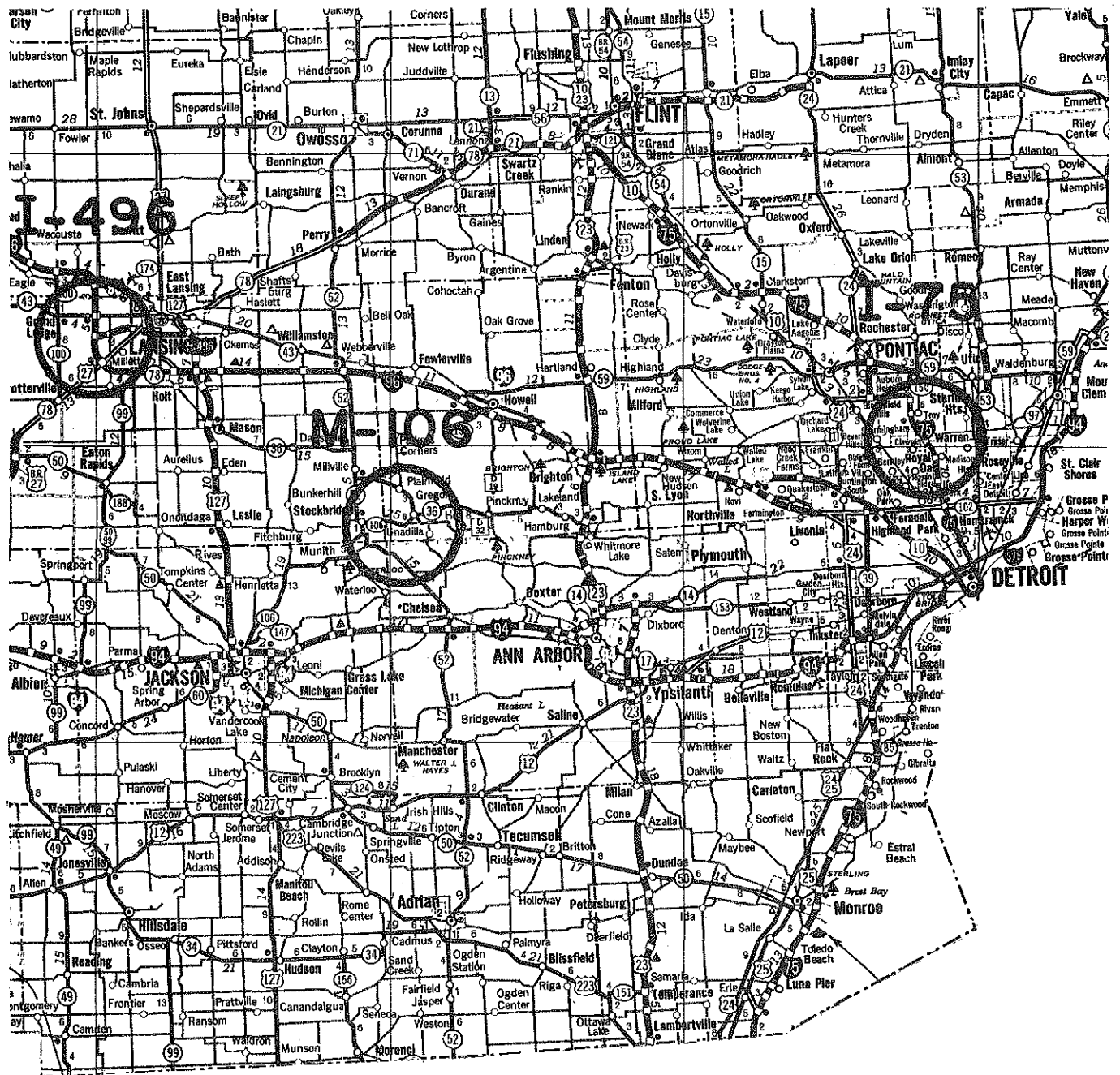

I-496

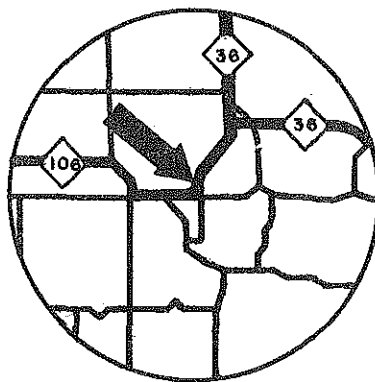

M-106

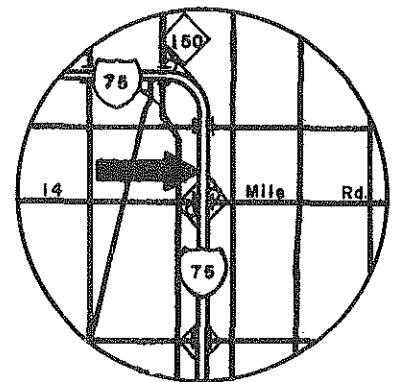

I-75

Figure 1 - LOCATIONS OF TEST SITES.

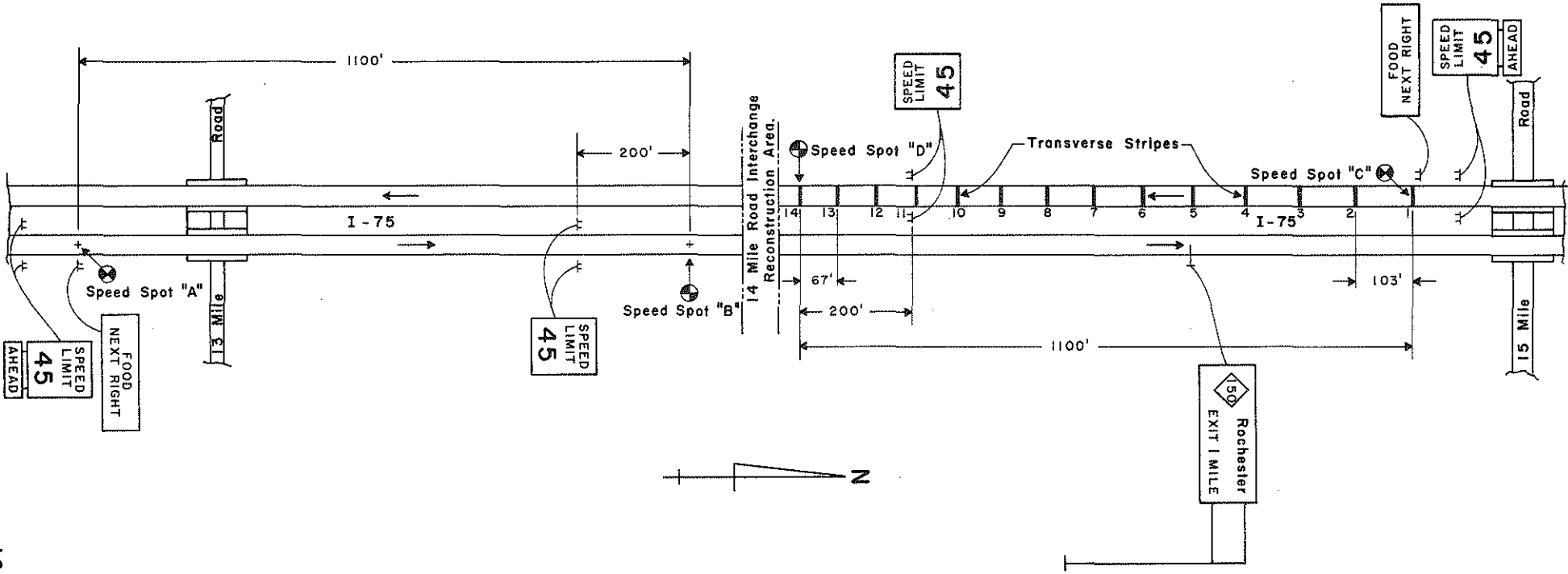

STRIPE CONFIGURATION

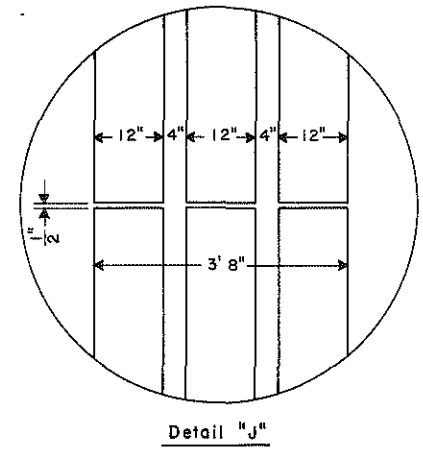
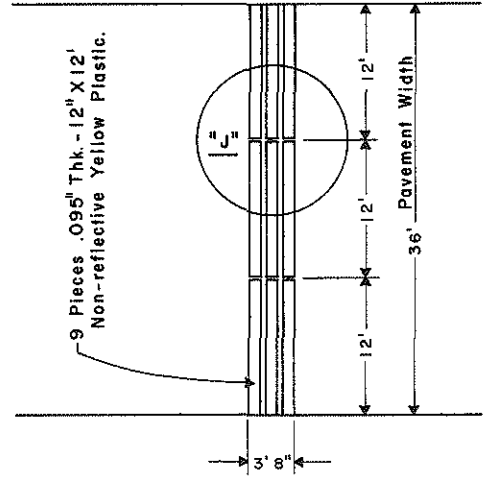

Figure 2 - TRANSVERSE PAVEMENT STRIPES ON I-75

were laid with 4 inch spacing between each sheet for the purpose of adding a slight "rumble" effect to the visual stimuli (Figs. 3 and 4). The spacing between each set of stripes varied gradually from 103 feet to 67 feet. The vendor of the product closely supervised the work for adherence to recommended installation procedure.

Spot speeds on all lanes were measured by radar at the first and the last stripe location on the southbound roadway, and at two locations on the northbound roadway which had the corresponding distances from the northbound speed control signs. (See Fig. 2). The first set of speed data was taken before the stripes were applied. The second set was obtained immediately after striping, and the third set about a month later. In addition to radar speeds, and about the same time that the third set of speeds were measured, spot speeds on only the right lanes at the four speed stations were taken by using loop detectors on the pavement.

The vehicles used in speed surveys, either by radar or pavement detectors, were parked on the freeway shoulder. Since this was a construction area where several other vehicles parked, the presence of the survey vehicles was not believed to affect the speed data.

Periods of low traffic volume were selected for speed measurements in order to obtain random sampling with minimal interaction between vehicles. Two radar speed meters were used at the two

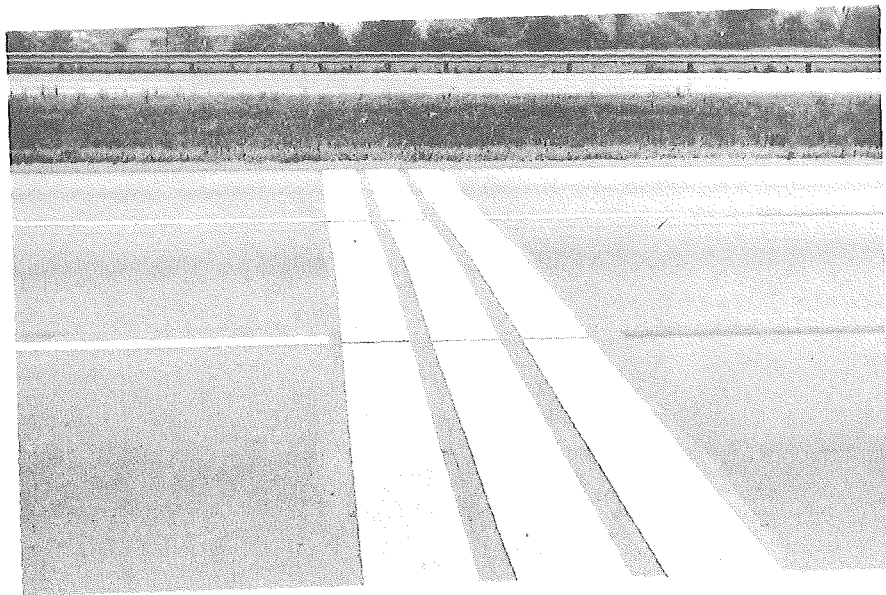

Fig. 3 - Side view of transverse stripes on I-75



Fig. 4 - General appearance of transverse stripes on I-75

speed stations for each direction of travel in an alternating pattern. One of the instruments operated for five minutes and was turned off, and then the other was turned on and used, etc., so that no electronic interference would occur between the two instruments. The use of two instruments was a precaution to keep the total survey time as short as possible and to sample traffic having the same speed characteristics which might vary if considerable time difference existed between the surveys at the two locations. Traffic volumes by five minute periods were counted for the duration of the radar surveys, and by 15-minutes during detector surveys.

The purpose in the use of loop detectors was a desire for a more accurate method of obtaining spot speeds. Radar speeds are not always accurate, especially under dense, multilane traffic conditions. The loop detection system was assembled from equipment available in the Department, and used two induction loops taped onto the pavement (Fig. 5), with a prescribed trap distance between them. Two electronic detectors were each connected to one of the loops and activated by a portable generator (Fig. 6). The output signals from the detectors were fed at a time interval measurement device functioning in combination with a paper tape printer (Fig. 7). These time interval data were converted to speeds by the office computer, based on the trap distance between the loops. At first a 32-foot trap distance was used. During the later experiments at other sites the use of a 29-foot 4-inch trap made occasional quick calculation

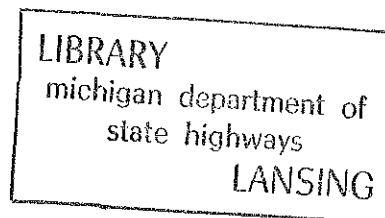



Fig. 5 - Induction loop taped onto pavement

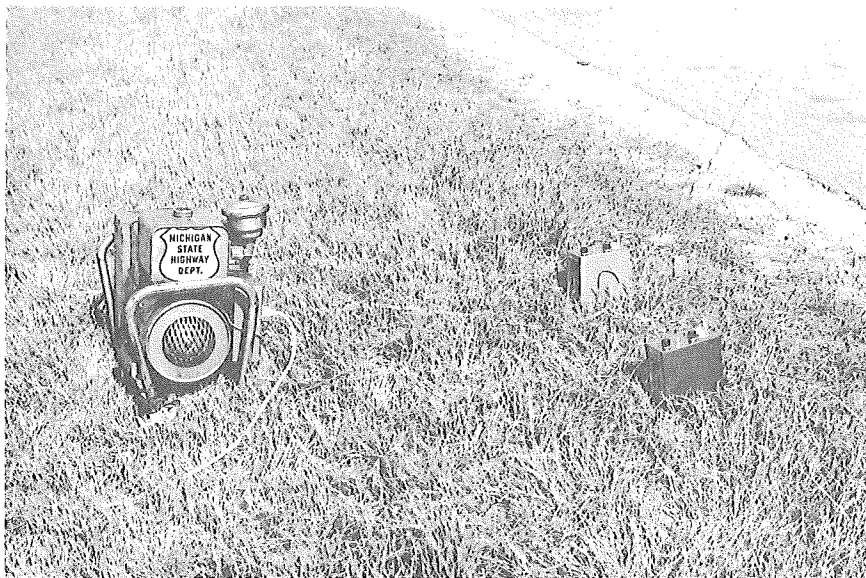

Fig. 6 - Electric generator and vehicle detectors

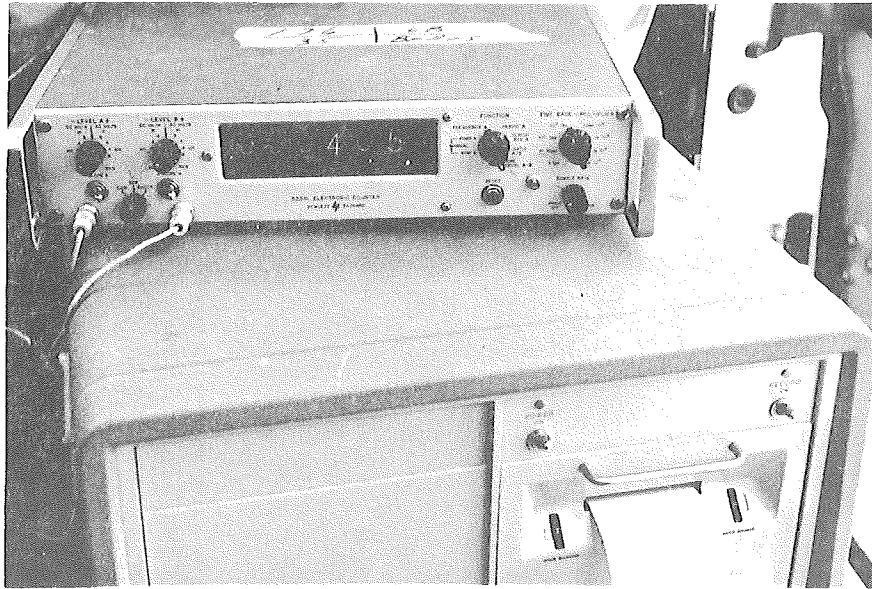

Fig. 7 - Electronic counter with time base,
coupled to tape printer

UMass Amherst Libraries - ILL



ILL: 82970660

Patron: **Fitzpatrick, Cole**

ILLiad TN: 874453

Thank you for loaning us the following item:

Title: Three experiments with transverse pavement stripes and rumble bars /

Author: Enustun, Nejad.

Pieces: 1

Lending Library's Due Date:

11/10/2011

This item is being returned to
Library, 3rd Floor- ILL

If there are any questions about this item, please give us a
call at 413-545-0553 or e-mail us at
ill@library.umass.edu.

Notes/Special Instructions:

I

possible in the field by dividing the elapsed time in seconds into the number 20.*

The speed survey by loop detectors was a comparison of the striped southbound pavement with the non-striped northbound pavement during the last phase of the study only. Also, as already mentioned, speeds were measured on only the right lanes of the total three lanes of the freeway in each direction.

Table 1 shows the average speeds measured by radar during the three phases of the study. The last column contains the average reductions in speeds between the upstream and downstream speed spots on the northbound and southbound roadways. Before the stripes were installed on the southbound pavement (Phase 1), the speed reduction caused by normal sign obedience on both the northbound and the southbound roads were slightly over 4 m.p.h. Immediately after striping the southbound road (Phase 2), the speed reduction in this direction increased to 8.3 m.p.h. A month later (Phase 3), however, it dropped to 4.3 which is about the same as the initial condition (Phase 1). At spot D, the downstream end of the stripes, there was no significant change in absolute speeds. Also, significantly, there was little change during Phases 1, 2 or 3 in the speed reductions on northbound lanes which were controlled only by signs.

Figure 8 contains cumulative distribution charts for the speeds

* Velocity = $\frac{\text{Distance}}{\text{Time}}$ or $V = \frac{D}{T} = \frac{29.3 \text{ ft./sec.}}{T} = \frac{29.3}{T} \cdot \frac{1}{1.47} = \frac{20}{T} \text{ mi./hr. (approx.)}$

Table 1

I-75 CONSTRUCTION AREA NEAR 14 MILE ROAD

Average Speeds on All Lanes
By Radar

Date	Test Phase	Direction	Spot	Average Speed	Average Speed Reduction A-B or C-D
8/29/69	PHASE 1: No Pavement Stripes	NB	A	63.2	4.1
			B	59.1	
		SB	C	59.3	4.2
			D	55.1	
9/ 8/69	PHASE 2: Stripes on SB Pavement	NB	A	61.5	4.6
			B	56.9	
		SB	C	64.5	8.3
			D	56.2	
10/13/69	PHASE 3: Stripes on SB Pavement	NB	A	61.1	4.6
			B	56.5	
		SB	C	59.2	4.3
			D	54.9	

Table 2

I-75 CONSTRUCTION AREA NEAR 14 MILE ROAD

Average Speeds on Right Lanes
By Loop Detectors

Date	Test Phase	Direction	Spot	Average Speed	Average Speed Reduction A-B or C-D
10/10/69	PHASE 3: Stripes on SB Pavement	NB	A	54.5	(Increase)
			B	58.4	-3.9
10/ 9/69	PHASE 3: Stripes on SB Pavement	SB	C	59.0	1.5
			D	57.5	

LEGEND

- - SPEEDS BEFORE ENTERING THE 45 M.P.H. ZONE.
- - SPEEDS AT BEGINNING OF THE 45 M.P.H. ZONE.

○ = BEFORE ZONE ● = BEGINNING OF ZONE
 85 Percentile Speed = 70 85 Percentile Speed = 67
 Average Speed = 63.2 Average Speed = 59.1
 Median Speed = 65 Median Speed = 58

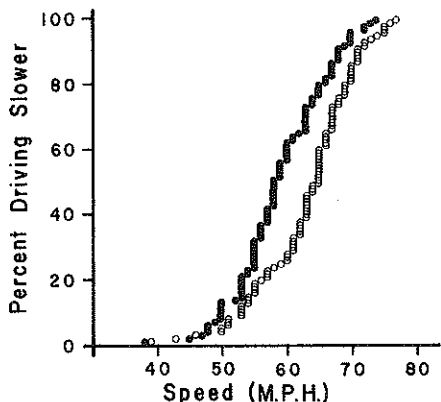

PHASE-1 SPEEDS ON NB I-75
 Before Striping SB Pavement (8-29-69)

○ = BEFORE ZONE ● = BEGINNING OF ZONE
 85 Percentile Speed = 66 85 Percentile Speed = 61
 Average Speed = 59.3 Average Speed = 55.1
 Median Speed = 60 Median Speed = 55

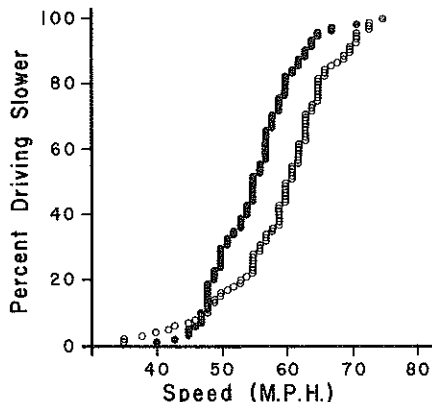

PHASE-1 SPEEDS ON SB I-75
 Before Striping SB Pavement (8-29-69)

○ = BEFORE ZONE ● = BEGINNING OF ZONE
 85 Percentile Speed = 69 85 Percentile Speed = 64
 Average Speed = 61.5 Average Speed = 56.9
 Median Speed = 62 Median Speed = 56

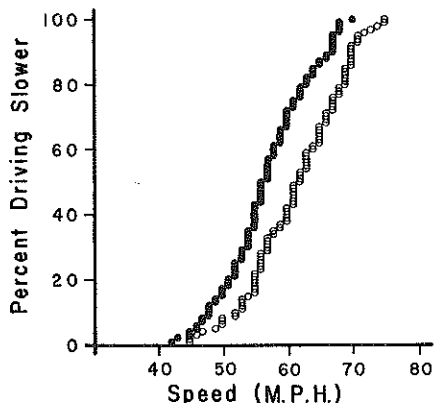

PHASE-2 SPEEDS ON NB I-75
 Immediately After Striping SB Pavement (9- 8-69)

○ = BEFORE ZONE ● = BEGINNING OF ZONE
 85 Percentile Speed = 71 85 Percentile Speed = 63
 Average Speed = 64.5 Average Speed = 56.2
 Median Speed = 65 Median Speed = 57

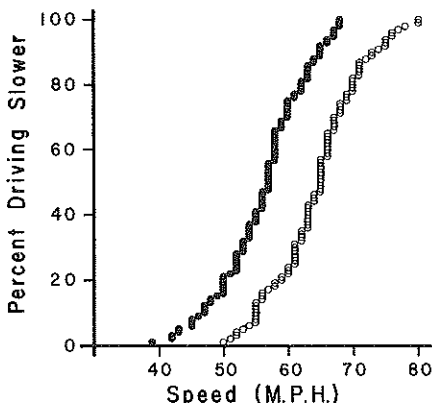

PHASE-2 SPEEDS ON SB I-75
 Immediately After Striping SB Pavement (9- 8-69)

○ = BEFORE ZONE ● = BEGINNING OF ZONE
 85 Percentile Speed = 72 85 Percentile Speed = 64
 Average Speed = 61.1 Average Speed = 56.5
 Median Speed = 60 Median Speed = 56

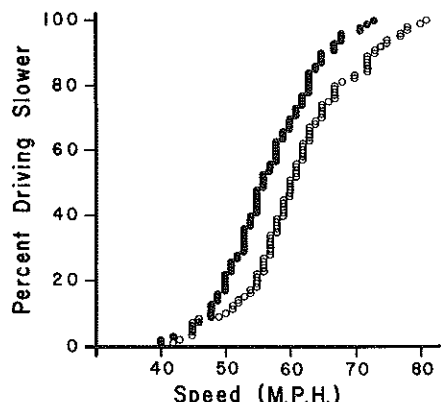

PHASE-3 SPEEDS ON NB I-75
 Six Weeks After Striping SB Pavement (10-13-69)

○ = BEFORE ZONE ● = BEGINNING OF ZONE
 85 Percentile Speed = 67 85 Percentile Speed = 63
 Average Speed = 59.2 Average Speed = 54.9
 Median Speed = 59 Median Speed = 55

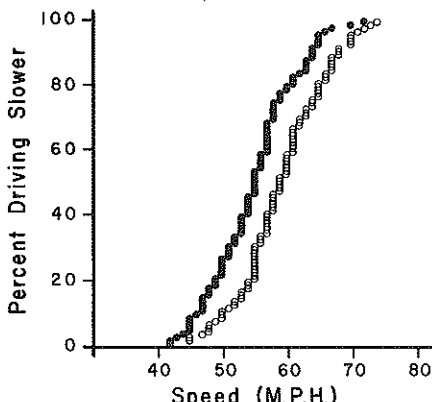

PHASE-3 SPEEDS ON SB I-75
 Six Weeks After Striping SB Pavement (10-13-69)

Fig. 8 - Effect of Pavement Stripes on Speed Distribution on I-75.

on all lanes as measured by radar, the average values for which were compared in Table 1. The three graphs on the left side of Figure 8 are for the northbound lanes, and those on the right are for southbound. The plots represent speeds of vehicles during the three phases of the study. The white circles show speeds at the upstream, and the black circles are for the downstream locations. The immediate effect of the pavement stripes is quite evident in the horizontal separation between the two curves in the middle chart at the right of Figure 8, showing speeds immediately after striping the southbound pavement.

Table 2 contains the results of speed surveys by loop detectors on the right lanes of the freeway during the last phase only. These results are somewhat unexpected because they show an increase of 3.9 m.p.h. in the average speed from the upstream location (Spot A) to the downstream location (Spot B) on the northbound road. It should be noted that these sets of speeds were measured on other days than those measured by radar, although the traffic control conditions were presumed to be the same in both cases (Test Phase 3). It is not known whether or not there were any unusual circumstances that day which caused the average speed at the upstream end (Spot A) to be abnormally low, so that traffic actually accelerated between the upstream and the downstream locations. It is possible that construction activities and equipment deployment could have caused such behavior of the traffic.

Average speed on the right lane of the southbound road shows a decrease of 1.5 m.p.h. It should be remembered that these speeds are not comparable with the set of speeds taken by radar which measured speeds on all three lanes. The speed differential of 1.5 m.p.h., although numerically small, is statistically significant here because the sample sizes are adequate (655 and 689 samples).

It is a known fact that speed differential within a stream of highway traffic increases the probability of accidents. Therefore, it is important that any traffic control device should not introduce conditions which tend to increase speed difference between vehicles. One parameter of the speed distribution is the standard deviation. Another is the skewness index. It is reported that a change in the speed distribution from non-normal to normal, as determined by the skewness index, is an effective method of reducing accidents. (5)

Tables 3 and 4 contain the standard deviations and skewness indices calculated for the various speed samples obtained during the study. They correspond to Tables 1 and 2, respectively. The critical location for speed variation is Spot D which is at the end of the striped roadway. In Table 3 the standard deviation figures for this location are 6.4, 6.7 and 6.5 for the three phases of the study. This slight increase is not significant. Skewness indices for the same spot have remained normal during the three phases. In fact the only circumstances when the skewness index was non-normal were at Spots A and C, which are the

Table 3

I-75 CONSTRUCTION AREA

Statistical Analysis of Speed Distributions on All Lanes

Direction	Speed Spot	Standard Deviation			Skewness Index		
		PHASE 1	PHASE 2	PHASE 3	PHASE 1	PHASE 2	PHASE 3
NB	A	7.4	7.1	8.6	-0.70 (Non-normal)	-0.26 (Normal)	+0.15 (Normal)
	B	6.9	6.5	7.2	-0.08 (Normal)	-0.02 (Normal)	+0.07 (Normal)
SB	C	8.1	6.7	6.7	-0.67 (Non-normal)	+0.05 (Normal)	-0.07 (Normal)
	D	6.4	6.7	6.5	+0.29 (Normal)	-0.37 (Normal)	+0.16 (Normal)

Table 4

I-75 CONSTRUCTION AREA

Statistical Analysis of Speed Distributions on
Right Lanes During Phase 3

Direction	Speed Spot	Standard Deviation	Skewness Index
NB	A	8.3	+0.39 (Non-normal)
	B	8.0	+0.29 (Non-normal)
SB	C	7.6	+0.19 (Non-normal)
	D	7.1	+0.19 (Non-normal)

upstream locations, before striping. Therefore, it appears that there is no appreciable change in the skewness of the speed distribution which is attributable to the pavement stripes.

From Table 4 it can be seen that the standard deviation on the right lane was considerably smaller on the southbound downstream spot in comparison with the northbound spot. Also, the skewness index was non-normal in all cases.

A study of traffic volumes counted during the speed surveys failed to show any correlation between flow rates and speed under the particular circumstances.

The only clues to individual driver reactions to the striping project were the comments from some of the Traffic and Safety Division staff who drove over it. Their observation, of course, cannot be totally objective since they were aware of the expected results. These comments, however, can be summed up as follows:

1. The stripes were effective in providing a gauge for rate of travel and deceleration.
2. They could be more effective if the stripes were wider.
3. A closer spacing would be preferable.
4. Rumble effect was negligible.
5. The installation was too far upstream in relation to the construction area, and traffic may speed up after leaving the striped section.

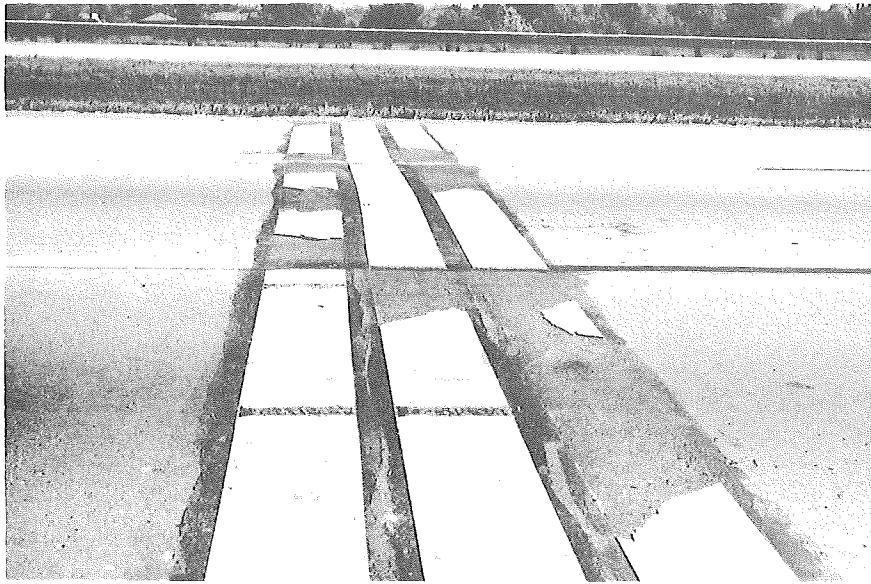

Fig. 9 - Plastic stripes after five weeks under traffic

Durability of the plastic sheets used for transverse pavement marking proved to be insufficient under the heavy and fast free-way traffic (ADT 30,000 in one direction). Figure 9 is a photograph of a typical failure, and was taken after a use of five weeks.

Pavement Stripes and Rumble Bars on M-106

To experiment with rumble bars in conjunction with pavement stripes, a search was made for another suitable location. Since the plastic marking material proved to be too short-lived in the I-75 experiment, it was desired to use pavement paint for the next experiment. This made it necessary to select a location where such a device may be applicable on a permanent basis, because it is difficult to eradicate paint.

A sharp curve on M-106 near the community of Gregory in Livingston County was selected as the next test site. This road is a two-lane, two-way rural highway, and the location had a record of one accident in 1968 and three in 1969. The southbound approach to the curve appeared to be the more critical one, and it was decided to conduct the tests on this approach. Figure 10 shows the general layout. Traffic is very light on this road, the ADT being 1,000.

The speed measurement apparatus developed for the I-75 tests, using pavement loop detectors, was used at spots A and B, shown in Figure 10, during the four phases of testing, except that during the fourth phase, tape switches instead of magnetic tape were used on the pavement. Also, at this test site, vehicle samples were caught first at the speed trap at A and again at B, making it possible to follow each vehicle and determine its actual speed drop individually. Any vehicle closely following another one was omitted from the sample. The equipment was housed in a van parked on a side road which was well hidden by a corn field so that it was not visible to approaching drivers.

The first set of speeds was measured before any pavement marking was done. The stripes were then painted by spraying yellow pavement-marking paint. The spacing was based on a flash frequency of two per second at the assumed travel speeds. It varied from 37 feet at the upstream end to 15 feet near the curve at the downstream end. There were 30 stripes in all. The first 14

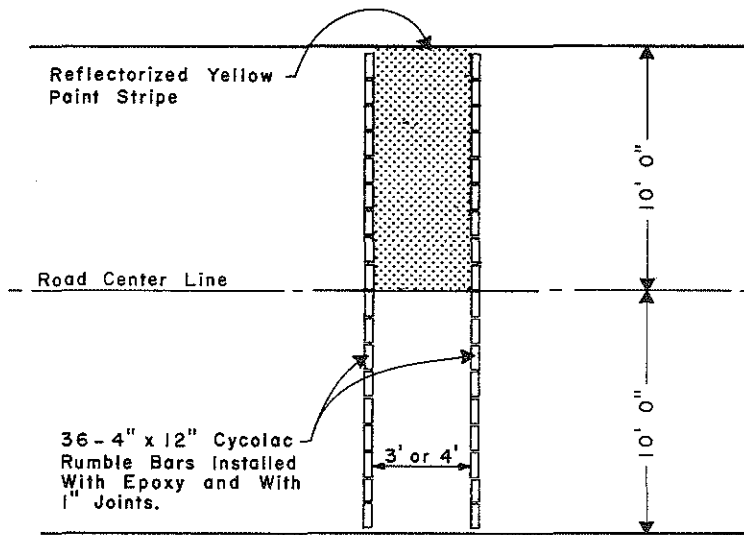
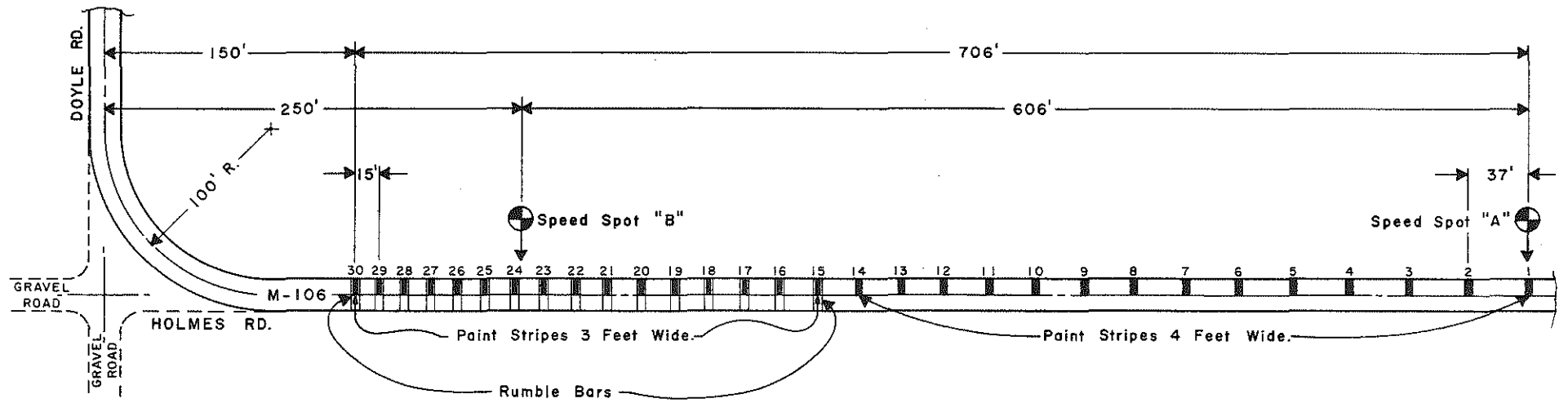

STRIPE & RUMBLE BAR DETAIL

Figure 10- TRANSVERSE PAVEMENT STRIPES AND RUMBLE BARS ON M-106.

stripes were four feet, and the rest were three feet wide. General appearance of the approach to the curve is seen in Figure 11. Reflective beads were spread by hand over the fresh paint. Night inspection, however, indicated that reflectorization was poor and spotty.

Speeds for the second phase of the study were measured after the stripes were completed. For the third study-phase, hard plastic rumble bars, yellow in color, four inches wide and 12 inches long were installed as shown in Figure 10. The bars were made of ABS (acrylonitrile, butadiene, styrene), had a cambered top surface $3/4$ inch high in the middle and $5/16$ inch high at the two sides. The underside had a waffle-shaped ribbed structure. A three-dimensional view is shown in Figure 12. The photograph in Figure 13 shows the appearance of the road with the bars installed.

The rumble bars were intended by the manufacturers for use on areas from where traffic was desired to be kept away, such as channelizing islands, shoulders, etc. They had not been used so far on the traveled way. Therefore, some testing was done with these devices outside of public highways before installing them on M-106. The first test was done on the road to the Grand Ledge Maintenance Garage. Three rows were laid and driven over in passenger vehicles and in empty and loaded trucks. The ride over them did not appear to be too rough. The material withstood heavy truck wheels with no damage. A temporary butyl adhesive which came in rolls four inches wide was used in this installation.



Fig. 11 - Paint stripes on M-106

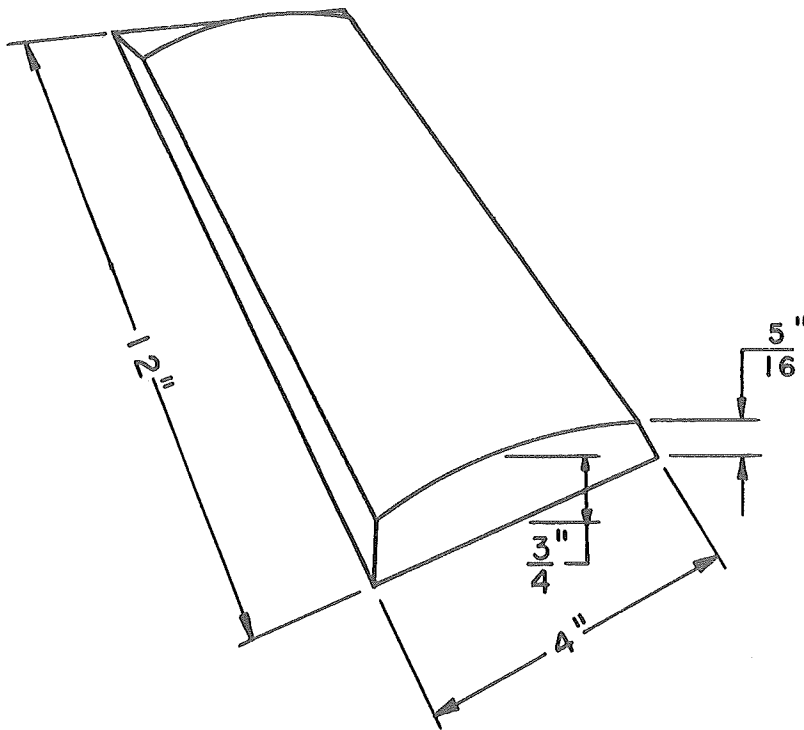

Figure 12-ABS PLASTIC RUMBLE BAR.



Fig. 13 - Rumble bars and paint stripes on M-106

The bars remained undisturbed for several months until they were dislodged by snow plowing.

The garage site did not allow testing the rumble bars at high speed. As a further precaution, the bars were next tested at one of the aprons of Willow Run Airport. One single row and a set of two rows, with 4'-2" between centers, were installed. The 4'-2" was the intended spacing to be used on the upstream end of the M-106 project. Test runs were made under a variety of speeds with a passenger car and a loaded truck. Two engineers, one technician and one foreman agreed that the jolt was not too harsh to be tried on a public road.

The rumble bars on M-106 were installed along both edges of the transverse paint stripes. Installation started from the downstream end nearest the curve, using epoxy adhesive. When the

installation was about half-way complete, there was a pause in the work awaiting delivery of additional adhesive. During this interval it was observed that several vehicles approaching the curve were driving on the left of the center line to avoid the bars. It was then decided to extend to both lanes the rumble bars already installed on the right lane. The first 14 paint stripes near the upstream end of the project were left without rumble bars.

It was deemed necessary to erect warning signs on the roadsides at the approaches to the project site from both directions on the state highway. These were regular diamond-shaped, yellow-background signs with the legend "Pavement Test Area Ahead". This was a precaution against claims of loss of control of driving due to the element of surprise. It can, of course, be argued that these signs had some effect on the test data.

The fourth phase of the study was one year after the paint installation. At this time all the rumble bars were removed from the pavement, so that this phase was comparable with Phase 2. More will be told later on the removal of the bars and the reaction of the drivers to these bars.

Figure 14 shows the speed reductions of the vehicles between the two speed measuring stations A and B. This chart shows smoothed out curves rather than plots of actual speeds as in Figure 8. The data were compiled, as mentioned before, by taking two speed

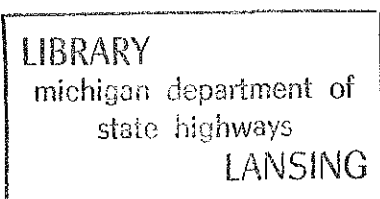

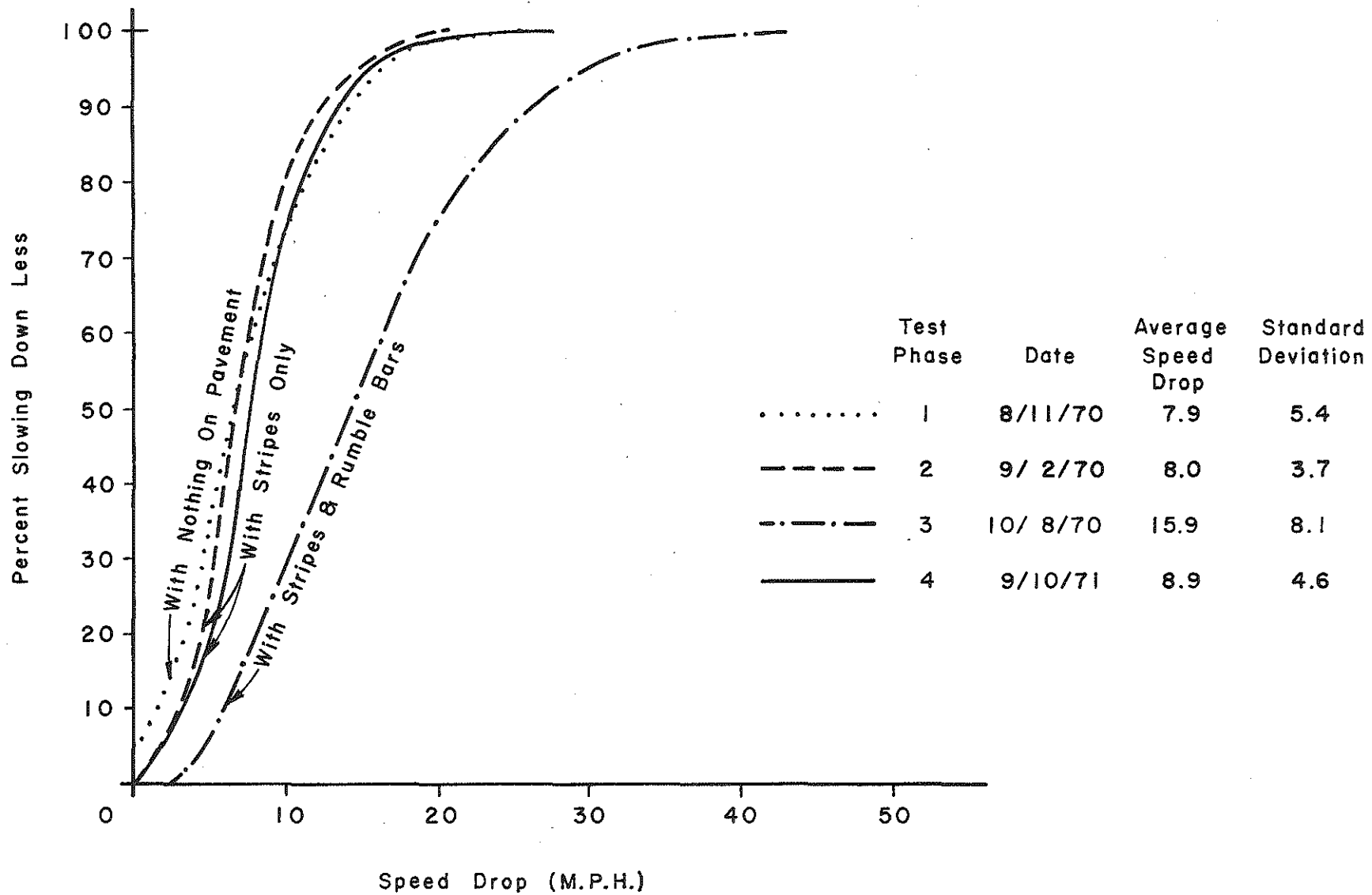

Figure 14-SPEED DROP OF INDIVIDUAL VEHICLES BETWEEN 1st AND 24th STRIPES ON M-106

measurements for each vehicle, by following individual vehicles. The average drop in speed during the four test phases is indicated in the tabulation in this Figure. The difference in the average speeds between Phases 1 and 2 is not significant. Neither is the difference between Phases 2 and 4. Phase 3, with rumble bars, however, is significantly different from the others. The characters of the three distribution curves are defined by the standard deviation quantities. The magnitude of the standard deviation would be an indicator of hazard, as discussed before. From this consideration it may be deduced that speed-reduction distribution improved during Phases 2 and 4, with the paint stripes alone, and worsened during Phase 3, with the rumble bars.

Figure 15 is a similar set of distribution curves for the four study phases. However, these are based on absolute speeds measured at Spot B near the downstream end of the test section. The average speeds during Phases 2, 3 and 4 were significantly different from Phase 1, with nothing on the pavement. Phase-3 speed, with the rumble bars, was also significantly different from Phases 2 and 4. Standard deviation improved during Phases 2 and 4, but worsened during Phase 3. If absolute speed near the downstream end of the marked area is considered as the relevant parameter, then it may be concluded that even with only the paint stripes, the speed reduction was significant. The reduction was 2.9 m.p.h. immediately after, and 2.0 m.p.h. one year after painting.

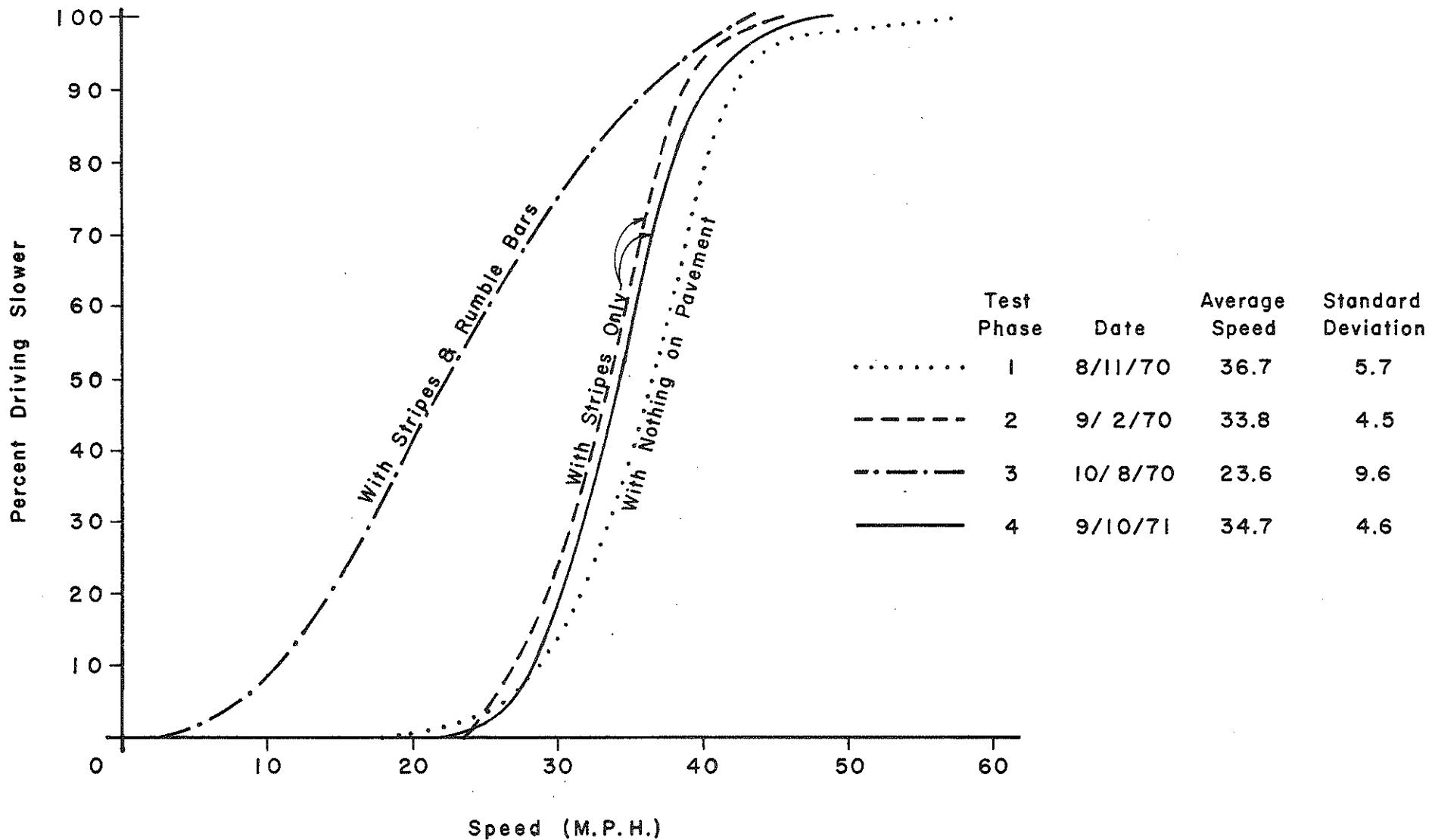

Figure 15-SPEED DISTRIBUTION OF VEHICLES PASSING OVER THE TEST ZONE ON M-106.

The skewness indices for speed distributions at Spot B are shown in Table 5, and were all normal although their signs and magnitudes varied slightly.

During speed measurements for all phases, some vehicles were observed to have traveled faster at the downstream location than at the upstream location. These were excluded from the data presented in Figure 14 showing the speed drops, but included in Figure 15 showing absolute speeds at the downstream location only.

As in the I-75 experiments, several engineers of the Traffic and Safety Division drove over the M-106 test area, especially during the rumble-bar phase. The reaction to the rumble bars was mixed. Some felt they were effective and not too harsh to ride over, while others expressed concern that they might panic some drivers. One characteristic of the bars was that, with the ordinary passenger-car suspension system, they felt rougher at low speed than at high.

The Department received a letter from the township clerk reflecting the criticism of local drivers who complained that the rumble bars were damaging their vehicles. Eventually the public dissatisfaction resulted in some parties surreptitiously removing some of the bars in such a way that a car could be driven with the left wheels along a cleared path and the right wheels on the narrow earth shoulder. This incident was interesting as an example of the present-day public's intolerance to any discomfort even

TABLE 5

M-106 NEAR GREGORY

Speed Analysis of Vehicles Passing Over the Test Zone

<u>Date</u>	<u>Test Phase</u>	<u>Average Speed</u>	<u>Standard Deviation</u>	<u>Skewness Index</u>
8-11-70	PHASE 1: Nothing on Pavement	36.7	5.7	+ 0.27 (Normal)
9-2-70	PHASE 2: After painting stripes	33.8	4.5	- 0.11 (Normal)
10-8-70	PHASE 3: After adding rumble bars	23.6	9.6	+ 0.13 (Normal)
9-10-71	PHASE 4: One year after painting stripes (No rumble bars)	34.7	4.6	+ 0.30 (Normal)

though this may be caused by an authorized agency for a legitimate reason. During the following winter season the ice blades forced the remaining rumble bars off the pavement.

It was earlier mentioned that there were four accidents during the two years of 1968 and 1969 before the experiments started. Later, a regular one-year before and one-year after study was made of the accident reports on record. August 30, 1969, when the striping was completed, was the base date. The study showed no accidents during the "before" year and two during the "after" year. Such small accident numbers do not, of course, indicate any improvement or worsening in a statistically significant manner. It was noted, however, that in one of the accidents, wherein the party at fault was a State Police trooper, it was mentioned that the driver lost control over the rumble strips in wet and misty weather.

Rumble Bars on I-496

A different type of rumble bar was next suggested for experimentation. This was made of flexible polyvinyl chloride, 7/16 inch thick and 3-1/2 inches wide. The edge facing traffic was beveled at a shallow slope of about 18 degrees, and the other edge had a steep angle of about 72 degrees (See Fig. 16). The bars came in 10-foot lengths with a tolerance of +2 inches -0 inch. This material appeared to be less severe in rumble effect than the earlier-tested variety, and it was decided to experiment with it at a new location.

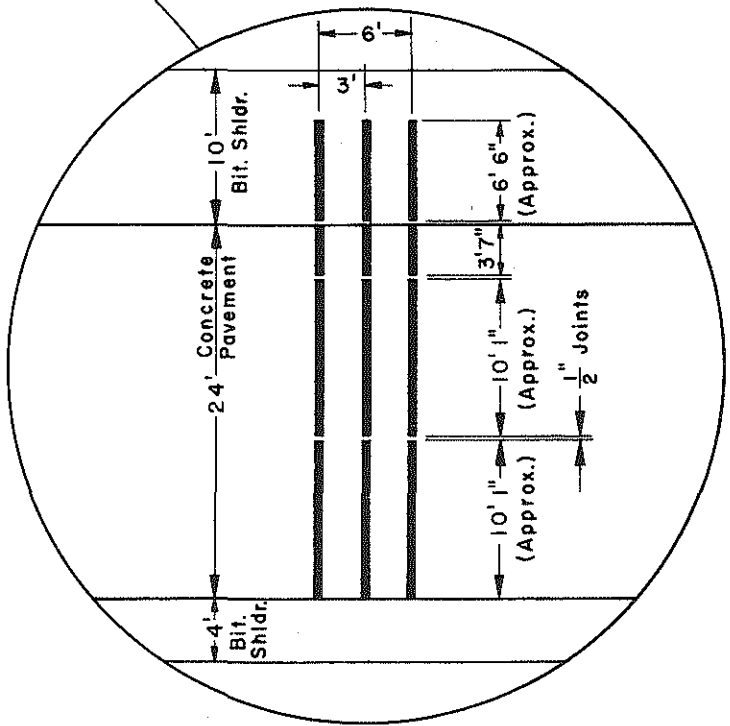
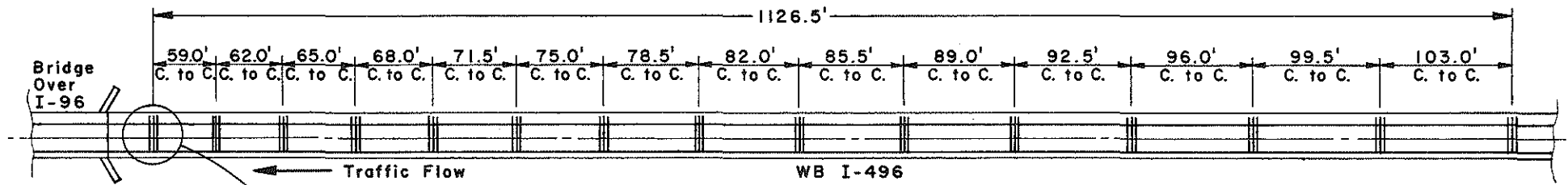

Installation Detail

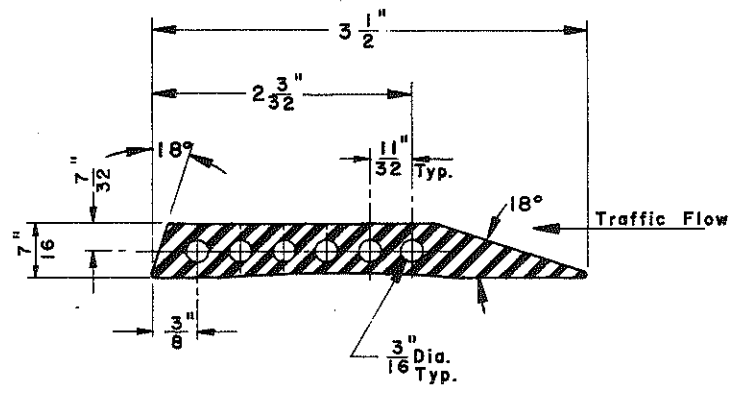

Cross-section of Rumble Bar

Figure 16-RUMBLE BAR INSTALLATION ON I-496

The loop ramp from westbound I-496 to southbound I-96 is at a temporary ending of I-496 west of Lansing (see Fig. 17). The safe loop speed is 35 m.p.h. Traffic has to slow down to this speed, from the regular freeway speed of 70 m.p.h., on the two westbound approach lanes. This location was selected as the final test site.

Three lengths of the rumble bar, adding to approximately 30 feet, were used on the approach to the loop so that they extended from the left edge of the 24-foot pavement, across the right edge and about six feet onto the right shoulder (see Fig. 16). Three parallel bars placed at three-foot centers were used to make up one rumble cluster. Fifteen clusters in all were used. The spacing between each rumble cluster diminished, in the direction of traffic flow, from 103 feet at the upstream end to 59 at the downstream end. The principle earlier described in laying out the pavement stripes was used in calculating the length of the total rumble area. A jolt frequency of one per second was used. A "Pavement Test Area Ahead" sign was erected for this location also. A driver's-eye view of the installation is shown in Figure 18, and a side view is seen in Figure 19.

The rumble produced was effective and yet not too harsh. Like the ABS bars, they had more punch at lower speeds such as 10 m.p.h. No driver complaints were heard. Favorable comments were made by some of the Traffic and Safety Division staff engineers who drove over the test area.

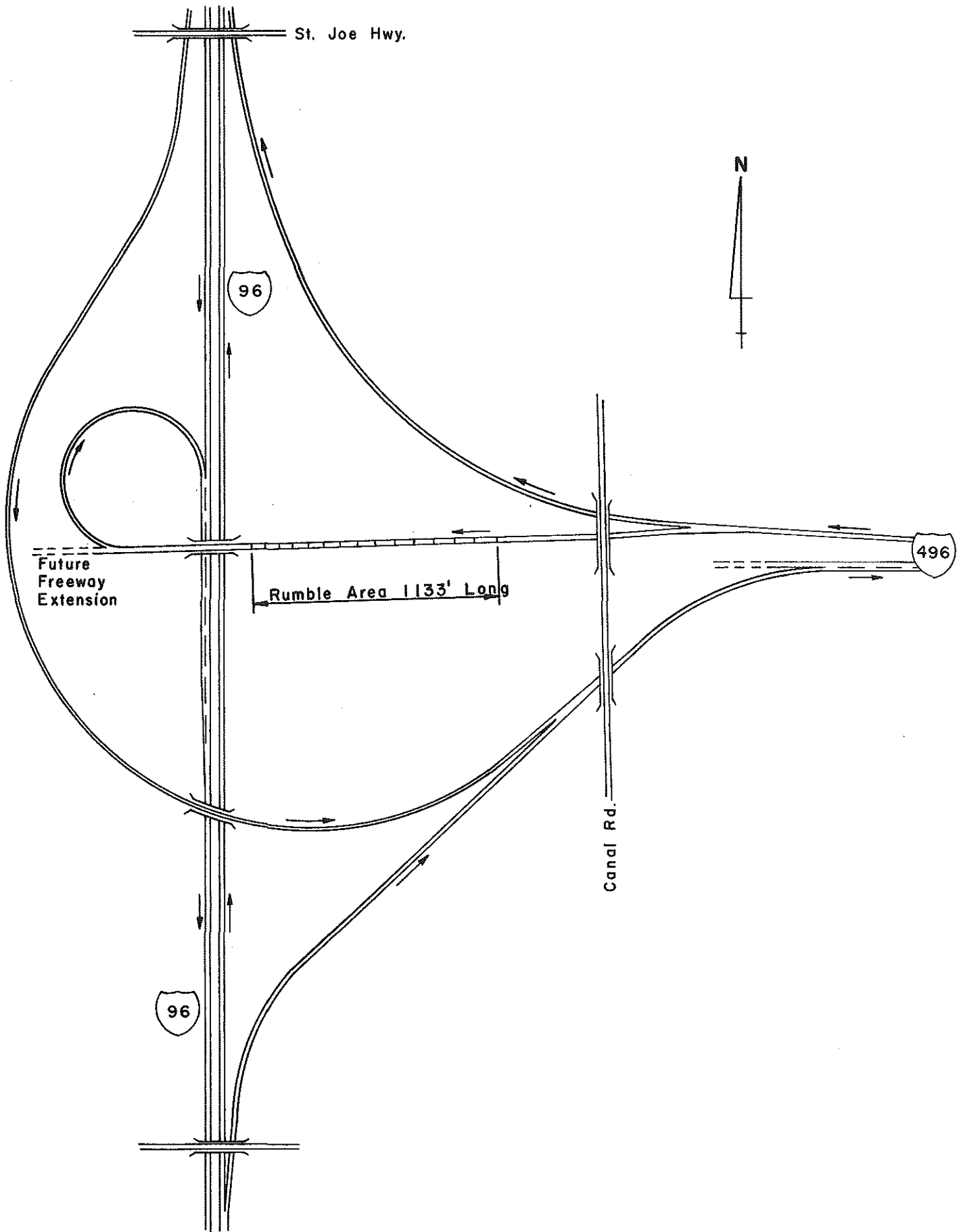

Figure 17- LOCATION OF I-496 RUMBLE AREA.

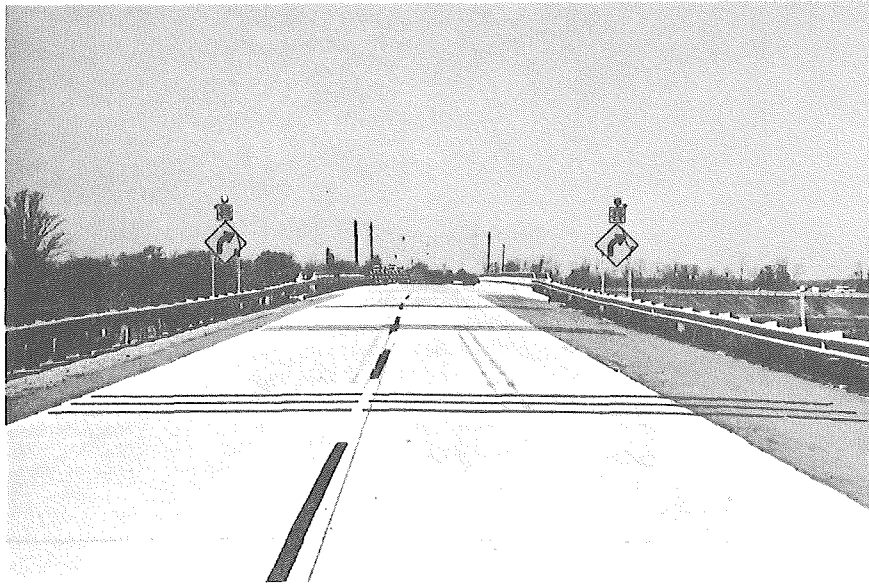

Fig. 18 - Driver's eye view of rumble bars on I-496

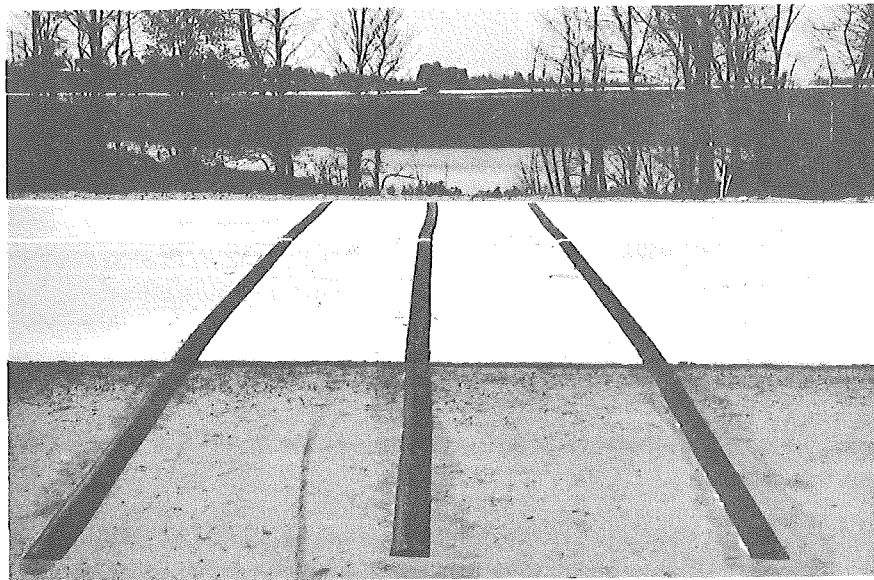

Fig. 19 - Side view of rumble bars on I-496

LIBRARY
michigan department of
state highways
LANSING

It should be mentioned also that the bars placed in triple rows served as visual striping, due to their black color in contrast with the light-colored concrete pavement.

Two different kinds of adhesive were used in installing the bars. An epoxy was used on the concrete traveled-way, and a mastic adhesive was used on the bituminous shoulder. The underside of the bars was abraded at the shop. The road surface was wire-brushed before installation by using a rotary brush operated by an air compressor. The material withstood the traffic fairly well under the existing flow which was estimated to be about 1,200 ADT. Installation was completed on May 7, 1971, and by November 11, after more than six months of use, only nine pieces out of a total of 180, or 5 percent, were dislocated by traffic. After two snow-plowing operations, by January, 1972, all the rumble bars came off the pavement.

The installation had been done according to the manufacturer's recommendations, and a representative of the company was present during the first day of the work. Examination of some of the loosened pieces later, however, indicated that some loose sand and concrete particles appeared stuck to the underside of the rumble bars. It would be advisable in any such work in the future to use an air blast to clean the pavement of any loose particles and dust due to the wire-brushing operation. Apparently, a hand brush which was used did not thoroughly sweep away the particles. Another recommendation would be to apply the adhesive onto the pavement rather than to the plastic bars as was the case.

Speed measurements for this test site were taken only at the downstream end of the rumble area. Tape switches extending across the two lanes were used to detect the vehicles. The pulse signals from the detectors were transmitted by radio to the time recorder. The recorder was kept in a van parked on a lower level of the interchange area so that it was not visible from the test section. The radio transmission system was devised out of some low-cost equipment used in remote-control garage-door openers.

The results of the speed study are shown in Table 6. The rumble

Table 6

I-496 WEST OF LANSING

Speed Analysis of Vehicles Passing Over the Test Zone

<u>Date</u>	<u>Test Phase</u>	<u>Average Speed</u>	<u>Standard Deviation</u>	<u>Skewness Index</u>
5-4-71	1. Before installation of rumble bars	50.0	8.6	+ 0.61 (Non-normal)
5-13-71	2. Immediately after installation	42.7	8.6	+ 0.10 (Normal)
6-10-71	3. One-month after installation	44.9	8.6	+ 0.08 (Normal)

bars resulted in an immediate drop of 7.3 m.p.h. (50.0 - 42.7) in the average speed of vehicles approaching the curve. As the novelty of the installation was gone in about a month, the average speed gained back 2.2 m.p.h. of the initial speed drop, and the net difference from the "before" speed became 5.1 m.p.h. (50.0 - 44.9).

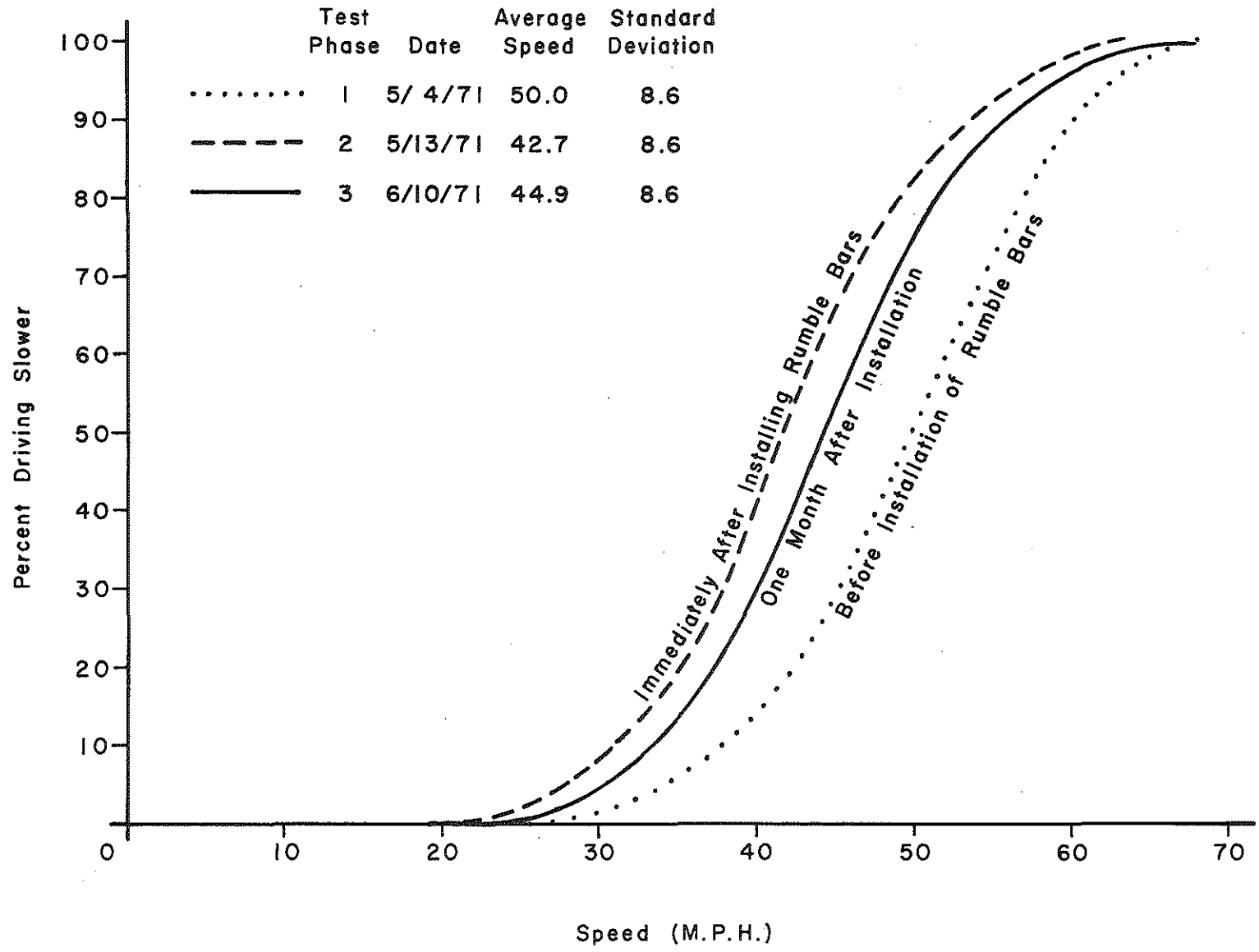

Figure 20 - SPEED DISTRIBUTION OF VEHICLES PASSING OVER THE TEST ZONE ON I-496.

Table 6 shows that there was no change in the standard deviation of the speed distributions in the three test phases. This type of rumble bar, therefore, did not have an adverse effect on the variance of speeds in the traffic stream as was the case with the bars used on M-106 where the standard deviation had increased (see Table 5). On the other hand, improvement in safety was indicated with the rumble bars because the skewness index changed from a non-normal value of +0.61 to normal values of +0.10 and +0.08, immediately after installation and one month after installation, respectively.

Speed distribution curves for the I-496 project are shown in Figure 20.

CONCLUSIONS AND RECOMMENDATIONS

1. The effect of yellow pavement striping in inducing speed reduction is marginal as much as can be ascertained by numerical speed analysis. This may be due to the prevalence of familiar in contrast to unfamiliar drivers who do not live or work in the vicinity. It is believed, however, that the stripes can be effectively used in hazardous locations to alert the unfamiliar drivers. This is the most important requirement of such devices. There is no device, short of very rough rumble strips, that can force all traffic to slow down to lower speeds. Most drivers adjust their speeds to the maximum possible to negotiate any particular situation with which they are familiar.
2. The colored stripes did not cause increased traffic hazard by introducing an abnormal increase in speed differential within the traffic stream.
3. Stripes should be at least five feet wide for a normal 70 m.p.h. freeway approach speed. Spacing should be adjusted for at least two flashes per second.
4. At the I-75 construction area, the stripes proved to have been installed too far in advance of the hazard area, causing some vehicles to accelerate after passing the striped road section.

5. Plastic sheet material failed in durability for transverse marking. Any rumble effect provided by the sheets was negligible. Pavement-marking paint was found suitable. For night reflectivity, beads should be spread evenly for good result.
6. Rumble devices producing a rough ride are undesirable because they are not tolerated by the public, and furthermore, they cause wide variations in the individual vehicle speeds within the traffic stream, thereby introducing an extra element of hazard. Devices producing a moderate rumble are tolerable and result in a significant reduction in traffic speed. The effect of such rumble devices on speed distribution is also advantageous since they change the skewness index of the distribution curve from non-normal to normal.
7. For temporary applications, such as construction areas, rumble bars are more appropriate than paint stripes since they can be removed easily when no longer needed.
8. Where a hazardous situation cannot be scheduled for improvement within a short time, aggregate and bituminous strips are recommended rather than commercial rumble bars tested in this study. The latter will be scraped off by winter de-icing equipment. Objection to tire noise by adjacent property owners must sometimes be considered with the rumble installations.

9. Speed reduction obtained by all devices diminished with the lapse of time. This suggests the conclusion that these devices are less effective the longer they are in use at a given location. However, the devices do not lose their impact on unfamiliar drivers which, as already mentioned, are the major concern at locations that confront them with unexpected situations.
10. Warning signs are advisable for areas with either stripes or rumble bars, to prevent Department liability.
11. We have found, like other States, that rumble bars should extend across all drivable road surfaces including paved shoulders, and regardless of the direction of traffic needing warning on two-way roadways. They are safest on one-direction roadways.
12. Rumble strips installed by a thermoplastic screed process whereby 1/4 inch high rumble bars are obtained should be tested for possible use. This would combine physical vibration and visual impact and may be durable to some degree for snow clearing operations done with special precaution. (15).

BIBLIOGRAPHY

1. Donald E. Orne, Memorandum to Files 11081-2(A), 11081-10(A), December 6, 1965.
2. J. C. Oppenlander, W. F. Bunte, and P. L. Kadakia, Department of Civil Engineering, University of Illinois, "Sample Size Requirements for Vehicular Speed Studies", Highway Research Board Bulletin 281, pp. 68-86, Washington, D. C. 1961.
3. J. C. Oppenlander, Department of Civil Engineering, University of Illinois, "Sample Size Determination for Spot-Speed Studies at Rural, Intermediate, and Urban Locations", Highway Research Record No. 35, pp. 78-80, Highway Research Board, Washington, D. C. 1963.
4. C. A. O'Flaherty, Centre for Transport Studies, University of Leeds; and R. D. Coombe, Department of Planning and Transportation, Greater London Council; "Estimating Speed Sample Sizes", Traffic Engineering and Control, Vol. 13, No. 4, London, England, August, 1971.
5. William C. Taylor, Ohio Department of Highways, "The Effect of Speed Zoning on Traffic Operations".
6. James I. Taylor, Pennsylvania State University, University Park, Pennsylvania, "A Study of Roadway Delineation Systems: Findings and Applications", 1971.
7. Michael L. Jones, Michigan Department of State Highways, "Rumble Strip Experiment", January 4, 1967.
8. New Jersey Department of Transportation, "Rumble Strips", October 1, 1967.
9. Dan W. Hoyt, "Rumble Strips", Traffic Engineering, November, 1968, pp. 38-41.
10. Wesley R. Bellis, "Development of an Effective Rumble Strip Pattern", Traffic Engineering, April, 1969, pp. 22-25.
11. L. Miller, O. A. Strassenmayer, J. O. Wilson, Connecticut State Highway Department, "Effect on Accident Experience of Rumble Area Installation at Connecticut Barrier Toll Stations", July, 1966.
12. State of Illinois Department of Public Roads and Buildings, "Rumble Strips Used as a Traffic Control Device", April, 1970.

13. "Rumble Strips Tested", Public Works, September, 1970, p. 74.
14. Donald F. Kamnikar, Wyoming Division, Federal Highway Administration, "A Rumble Heard for Highway Safety", Highway Focus, May, 1971, pp. 35-39.
15. "Screed Thermoplastic is Used to Form Reflective Rumble Strips in Cleveland", Prismo Universal - Hot Spray Plastic News, Vol. 1, No. 3, October, 1970.