

NOT TO SCALE

File: RefDoc/TR/Signals/Web/Sp Det/Fin/SIG031B.dgn Rev. 11/05/18



PREPARED BY  
TRAFFIC AND SAFETY

ENGINEER OF DELIVERY

ENGINEER OF DEVELOPMENT

(SPECIAL DETAIL)

FHWA APPROVAL DATE

MICHIGAN DEPARTMENT OF TRANSPORTATION  
BUREAU OF HIGHWAYS DELIVERY STANDARD PLAN FOR

TRAFFIC SIGNAL MAST ARM POLE AND  
MAST ARM DETAILS - CATEGORY II

DRAWN BY:

CHECKED BY:

PLAN DATE

SIG-031-B

SHEET  
1 of 6

ROUND TAPERED STEEL MAST ARM			
MAST ARM LENGTH	* MAST ARM DIMENSIONS	MTG HT SINGLE	MTG HT TWIN
20'-0"	0.2500"-8.50" x 5.70" x 20'-0"	19'-0"	18'-6" & 21'-0"
25'-0"	0.2500"-9.50" x 6.00" x 25'-0"		
30'-0"	0.2500"-10.50" x 6.30" x 30'-0"		
35'-0"	0.4290"-12.00" x 10.60" x 10'-0"		
	0.1793"- ** x 7.50" x **		
40'-0"	0.5000"-12.00" x 10.60" x 10'-0"		
	0.1793"- ** x 6.80" x **		
45'-0"	0.5000"-12.00" x 9.90" x 15'-0"		
	0.1793"- ** x 6.10" x **		
50'-0"	0.7500"-12.00" x 9.20" x 20'-0"		
	0.1793"- ** x 5.36" x **		

ROUND TAPERED STEEL MAST ARM POLE		
* POLE DIMENSIONS	LUMINAIRE ARM	MAST ARM LENGTH (FT)
0.313"-14.00" x 10.92" x 22'-0"	NO	20, 25
0.313"-14.00" x 9.94" x 29'-0"	YES	30, 35
0.358"-14.00" x 10.92" x 22'-0"	NO	40, 45
0.358"-14.00" x 9.94" x 29'-0"	YES	
0.478"-14.00" x 10.92" x 22'-0"	NO	50
0.478"-14.00" x 9.94" x 29'-0"	YES	

POLE TUBE TAPER IS 0.140 IN/FT

\* DIAMETERS GIVEN ARE O.D.

NOTE: ONLY USE THE MAST ARM LENGTHS WITH POLE SIZES AS INDICATED IN TABLE ABOVE

MAST ARM TUBE TAPER IS 0.140 IN/FT

\* DIAMETERS GIVEN ARE O.D.

\*\* TO BE DETERMINED BY CONTRACTOR BASED ON REQUIRED MAST ARM LENGTH AND TELESCOPIC SPLICE LENGTH.

**NOTES:**

1. THE DESIGN OF THIS STRUCTURE IS BASED ON THE 2001 AASHTO STANDARD SPECIFICATIONS FOR STRUCTURAL SUPPORTS FOR HIGHWAY SIGNS, LUMINAIRES AND TRAFFIC SIGNALS FOR 90 MPH WIND LOAD AND CATEGORY II WITH GALLOPING, NATURAL WIND GUSTS, AND TRUCK INDUCED FATIGUE LOADS.
2. WELD THE LONGITUDINAL ARM SEAM ON THE INBOARD AND OUTBOARD SECTIONS OF THE TELESCOPIC FIELD SPLICE WITH A COMPLETE JOINT PENETRATION (CJP) WELD A MINIMUM OF 36 INCHES LONG. IN ADDITION, LONGITUDINAL SEAM WELDS MUST BE CJP FOR A MINIMUM OF 6 INCHES FROM TUBE TO PLATE CJP WELDS.
3. SEAM WELDS MUST BE 90° ± FROM HAND HOLE AT BASE.
4. LUMINAIRE ARM IS 11 GAUGE ROUND STEEL WITH 0.140 INCH PER FOOT TAPER.
5. BACKING BAR FOR PIPE TO BASE PLATE (Ø) AND MAST ARM TO MAST ARM PLATE MUST BE MINIMUM 5/16 INCH X 2 INCH PLATE.
6. 1/2 INCH DIAMETER (Ø) ROUND STOCK C-HOOK ATTACHED TO ALL POLE SIZES. 3/4 INCH SCHEDULE (SCH.) 40 PIPE ATTACHED TO ALL POLE SIZES AND INBOARD AND OUTBOARD ARM.
7. S.S. DENOTES STAINLESS STEEL. GA. DENOTES GAUGE. O.D. DENOTES OUTSIDE DIAMETER. I.D. DENOTES INSIDE DIAMETER. H.S. DENOTES HIGH STRENGTH.

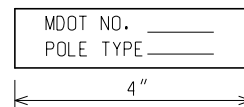
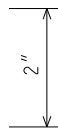
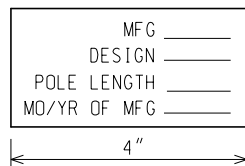
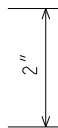
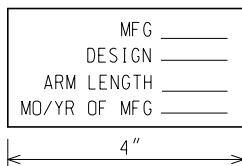

**ARM/POLE S.S. ID TAG DETAIL**

TO BE ATTACHED TO POLE OR MAST ARM AT LOCATIONS SHOWN 4" FROM BASE OF TUBE BELOW HANDHOLE WITH (4) #8 x 3/8" S.S. TYPE U DRIVE SCREWS.  
(LETTERS STAMPED IN 3/8" CHARACTERS)

**BASE S.S. ID TAG DETAIL**

WELD TAG TO EDGE OF BASE Ø  
(LETTERS STAMPED IN 3/8" CHARACTERS)

NOT TO SCALE

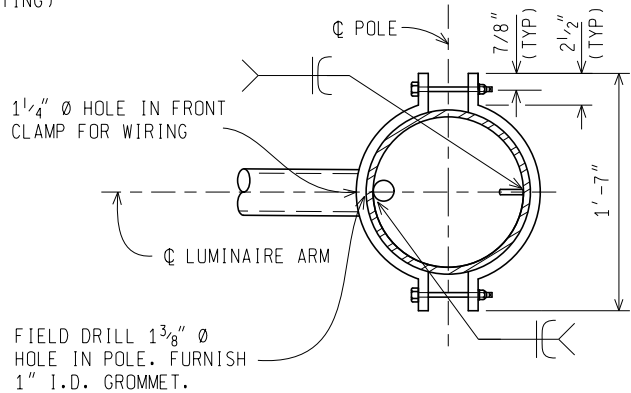
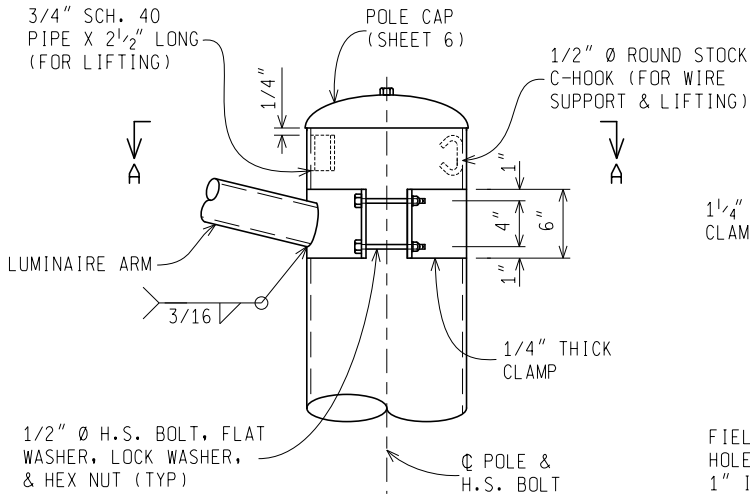

**DETAIL A**

**SECTION A-A**

ORIENTATION OF SCH. 40 PIPE 180° FROM HAND HOLE AT BASE & C-HOOK 180° FROM SCH. 40 PIPE

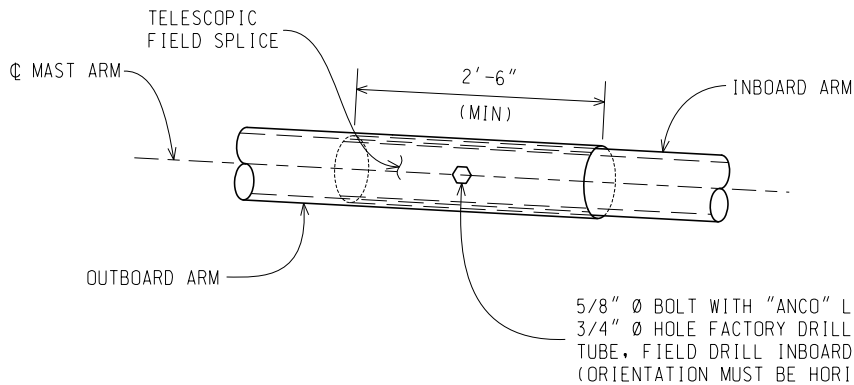

**DETAIL B**

(35'-0" ARMS AND GREATER)

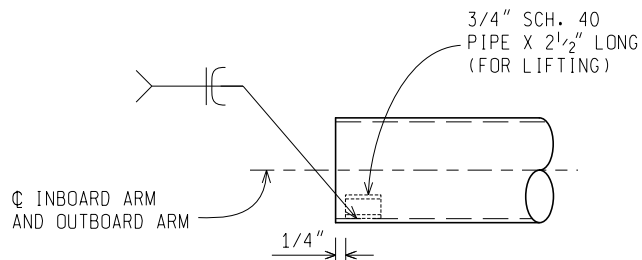

**INBOARD/OUTBOARD ARM LIFTING DEVICE**

NOT TO SCALE

MICHIGAN DEPARTMENT OF TRANSPORTATION  
BUREAU OF HIGHWAYS DELIVERY STANDARD PLAN

FHWA APPROVAL DATE

SIG-031-B

SHEET  
3 of 6

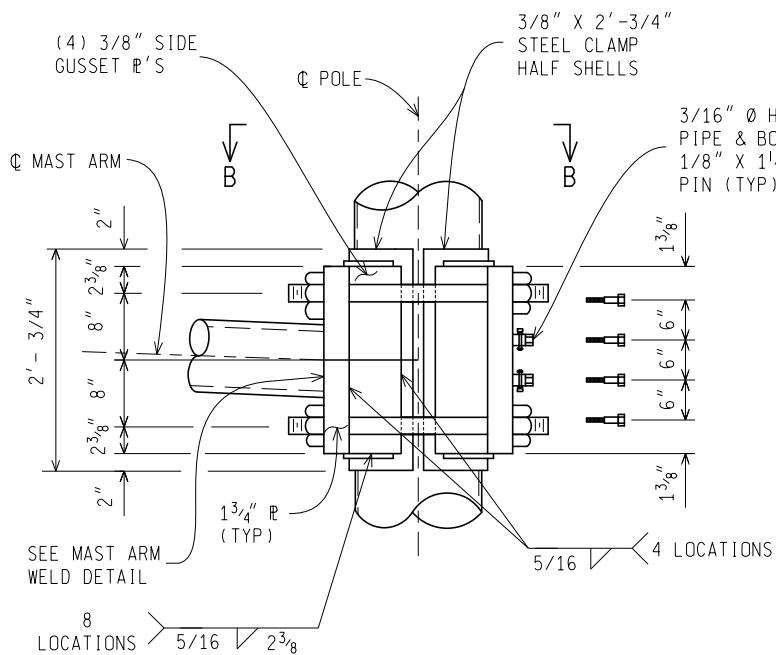

**DETAIL C**

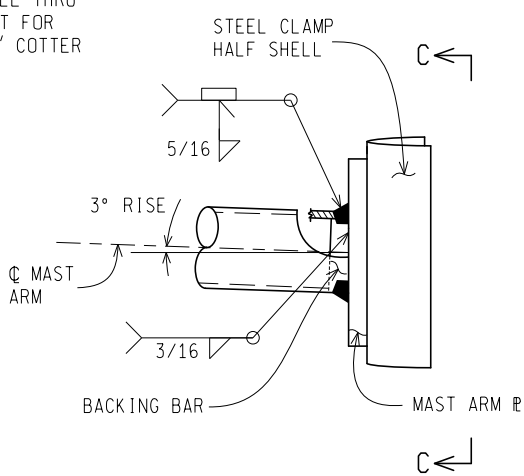

**MAST ARM WELD DETAIL**

SIDE GUSSET P'S AND SADDLE P'S NOT SHOWN FOR CLARITY

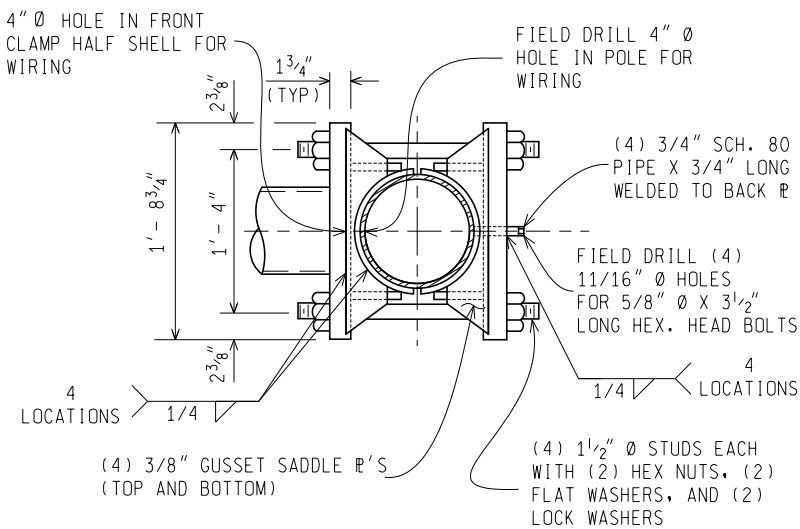

**SECTION B-B**

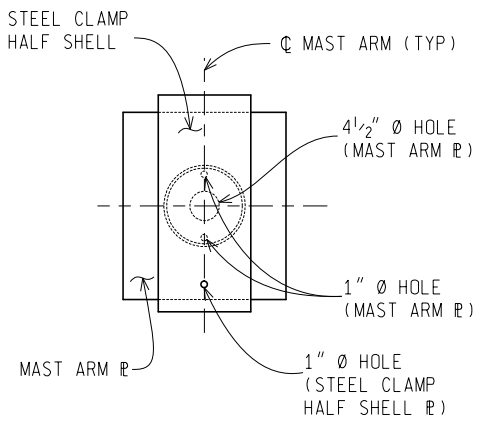

**SECTION C-C**

SIDE GUSSET P'S AND SADDLE P'S NOT SHOWN FOR CLARITY

NOT TO SCALE

MICHIGAN DEPARTMENT OF TRANSPORTATION BUREAU OF HIGHWAYS DELIVERY STANDARD PLAN	FHWA APPROVAL DATE	PLAN DATE	SIG-031-B	SHEET 4 of 6
File:RefDoc/TR/Signals/Web/Sp Det/F in/SIG031B.dgn Rev. 11/05/18				

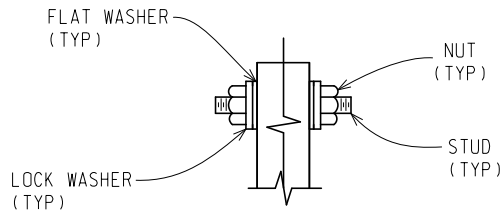

### MAST ARM CLAMP WASHER PLACEMENT

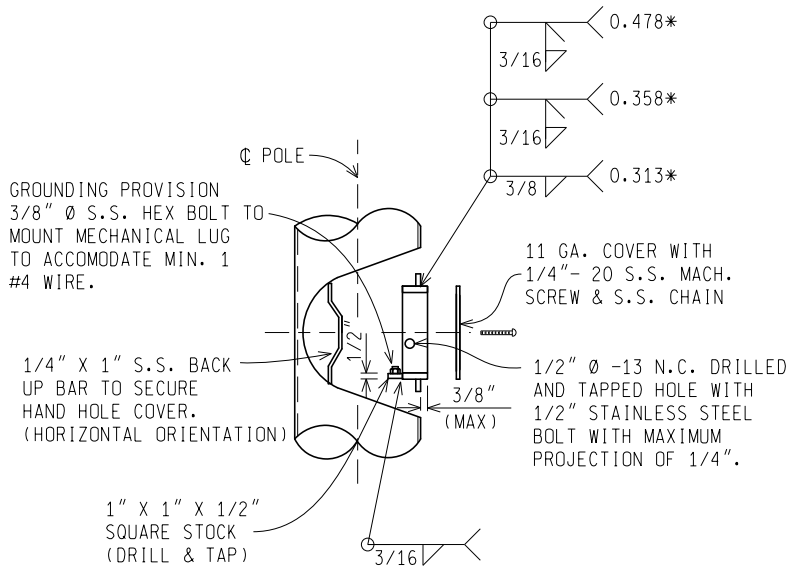

**6" X 10" BAR BOTTOM HAND HOLE**

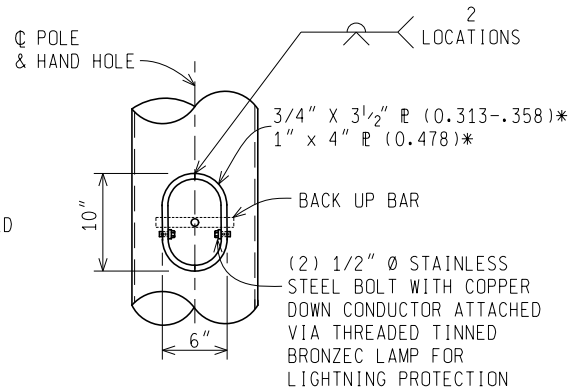

**6" X 10" BAR BOTTOM HAND HOLE**

(VIEW ROTATED 90 DEGREES)

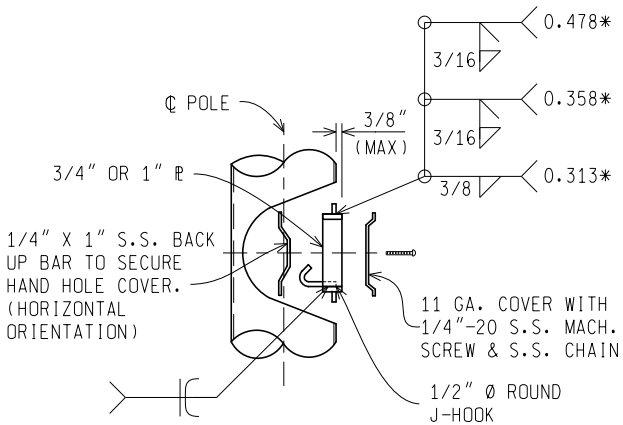

**4" X 6 1/2" BAR TOP HAND HOLE**

DESIGN WITH 29'-0" POLE ONLY

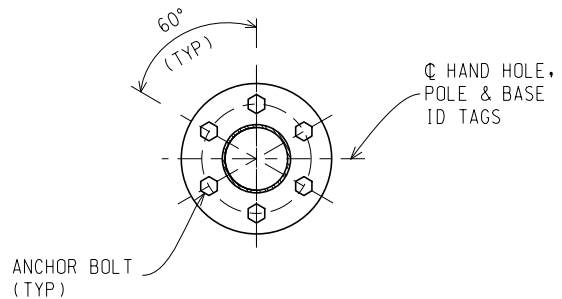

**ORIENTATION OF HAND HOLE**

\* THICKNESS OF POLE

NOT TO SCALE

MICHIGAN DEPARTMENT OF TRANSPORTATION  
BUREAU OF HIGHWAYS DELIVERY STANDARD PLAN

FHWA APPROVAL DATE

SIG-031-B

SHEET  
5 of 6

File:RefDoc/TR/Signals/Web/Sp Det/F in/SIG031B.dgn Rev. 11/05/18

PLAN DATE

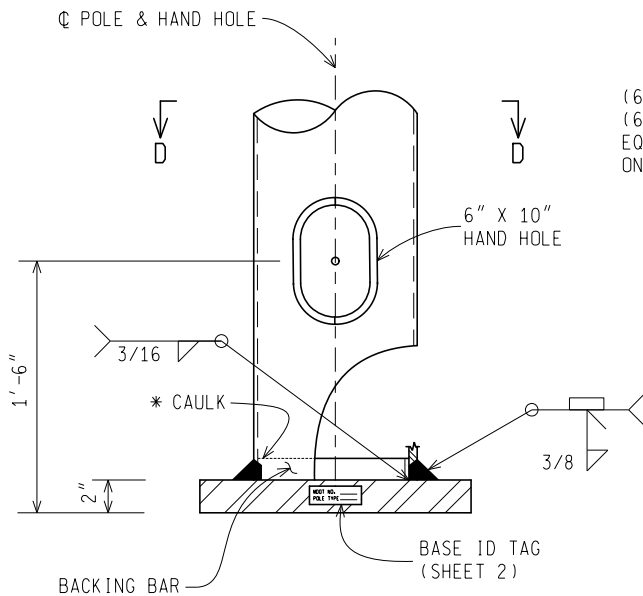

**DETAIL D**

(VIEW ROTATED 90 DEGREES)

\* SEAL JOINT WITH CAULK AFTER GALVANIZING

(6) 2 1/16" Ø HOLES FOR  
 (6) 1 3/4" Ø ANCHOR BOLTS  
 EQUALLY SPACED AT 60°  
 ON A 24" Ø BOLT CIRCLE

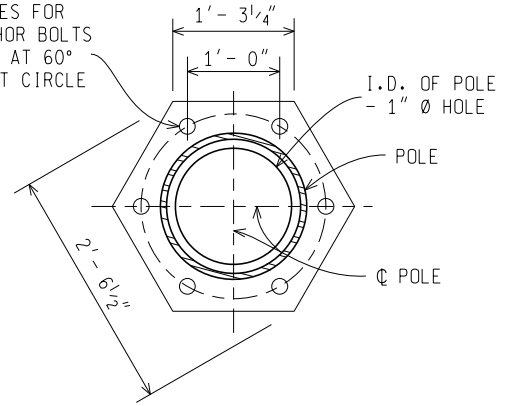

**SECTION D-D**

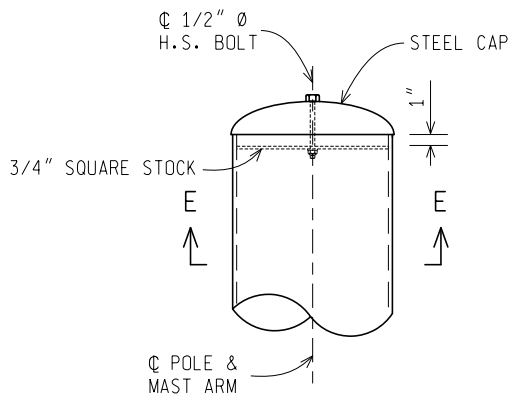

**POLE AND MAST ARM CAP DETAIL**

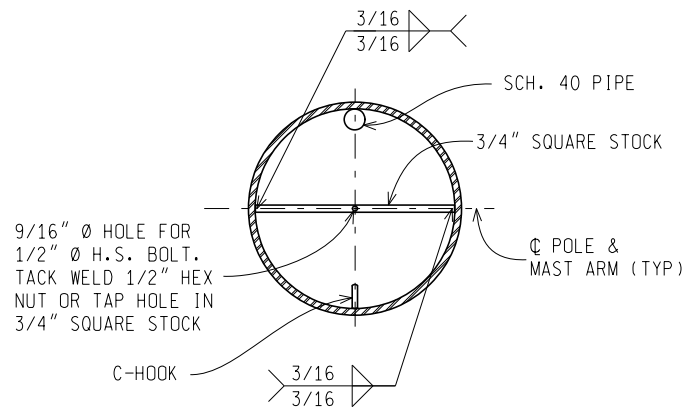

**SECTION E-E**

NOT TO SCALE

MICHIGAN DEPARTMENT OF TRANSPORTATION  
 BUREAU OF HIGHWAYS DELIVERY STANDARD PLAN

FHWA APPROVAL DATE

SIG-031-B

SHEET  
 6 of 6