

A DETAIL - TYPICAL SIGNAL DISPLAYS
N.T.S.

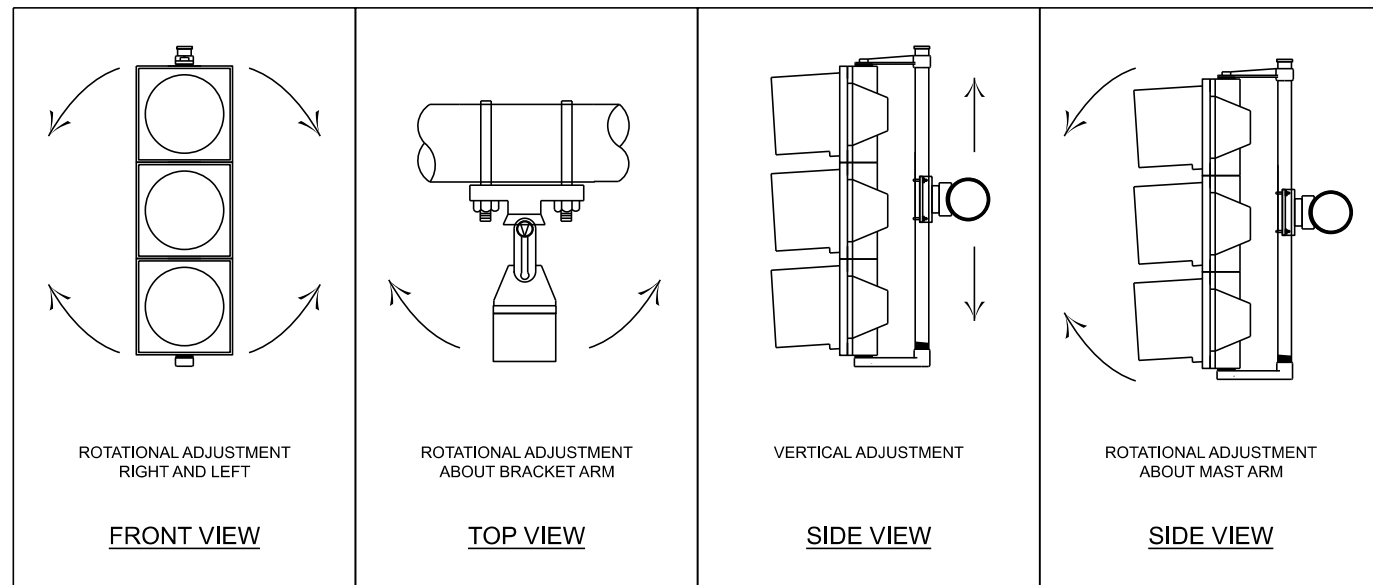

B DETAIL - SIGNAL HEAD BRACKET ADJUSTMENT
N.T.S.

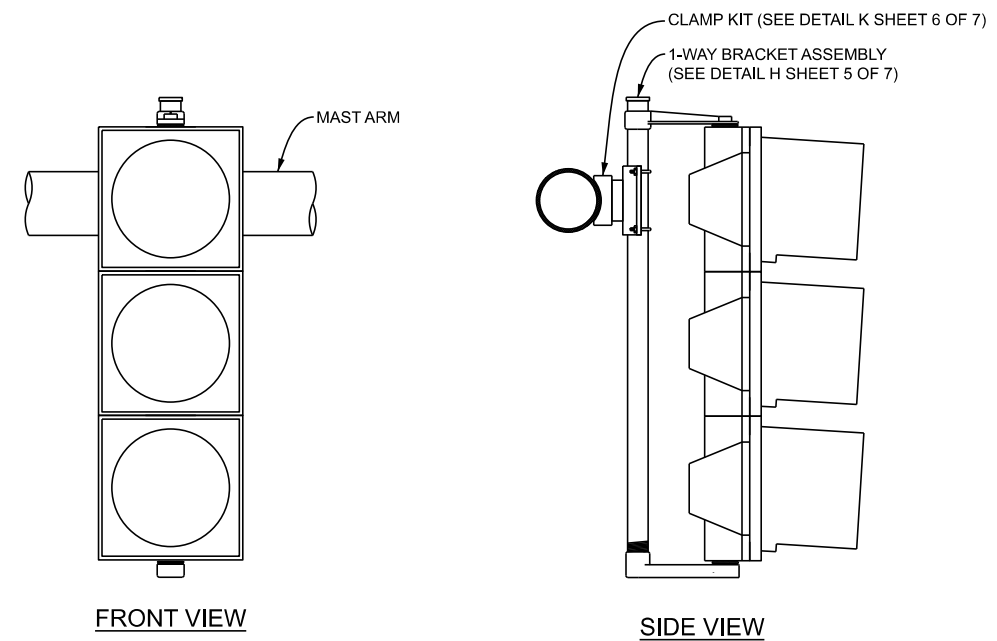

C DETAIL - 1W-3C
N.T.S.

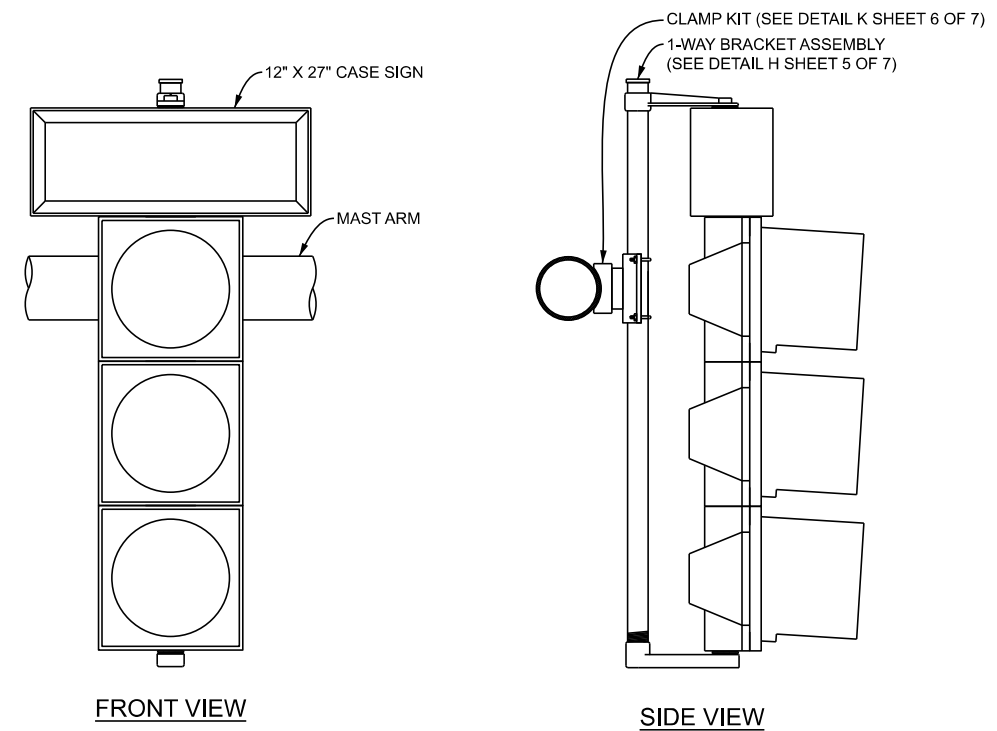

D DETAIL - 1W-3C WITH 12\"/>

APPROVED BY: _____
DIRECTOR, BUREAU OF FIELD SERVICES



APPROVED BY: _____
DIRECTOR, BUREAU OF DEVELOPMENT

DEPARTMENT DIRECTOR
BRADLEY C. WIEFERICH, PE

(SPECIAL DETAIL)
FHWA APPROVAL

02/21/2024
PLAN DATE

SIG-301-A

SHEET
1 OF 7



DEPARTMENT DIRECTOR
BRADLEY C. WIEFERICH, PE

(SPECIAL DETAIL)
FHWA APPROVAL

02/21/2024
PLAN DATE

SIG-301-A

SHEET
2 OF 7

SECT

STANDARD PLAN FOR
MAST ARM MOUNTED
T.S. BRACKET ASSEMBLY

STANDARD PLAN FOR
MAST ARM MOUNTED
T.S. BRACKET ASSEMBLY

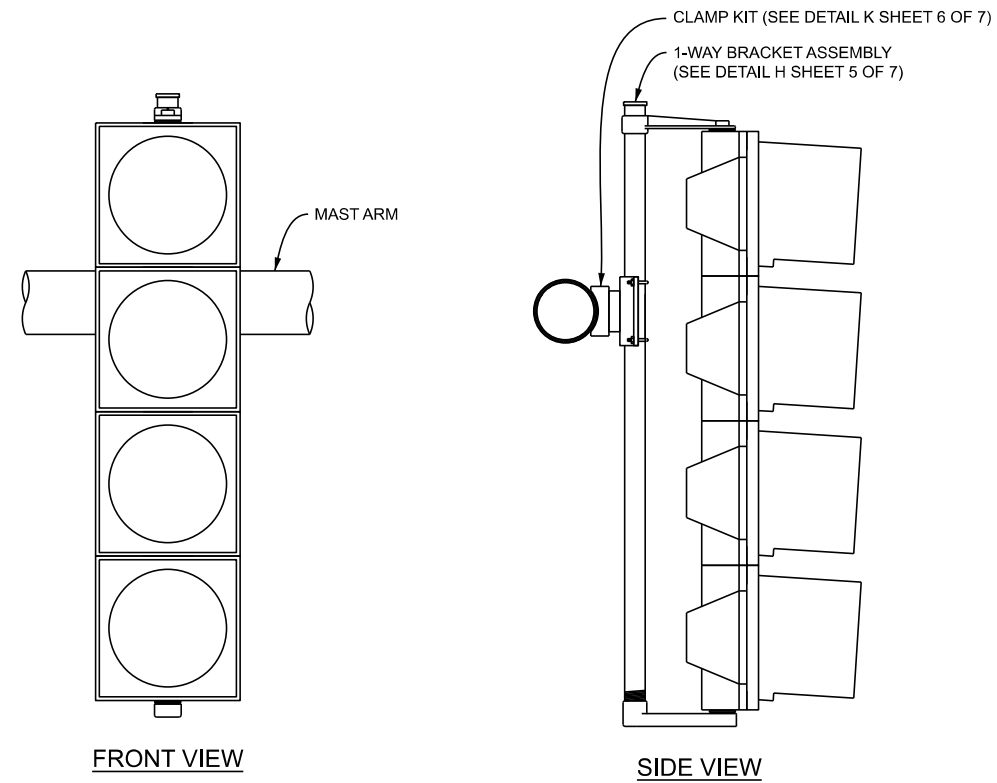

E DETAIL - 1W-4C (FYA)
N.T.S.

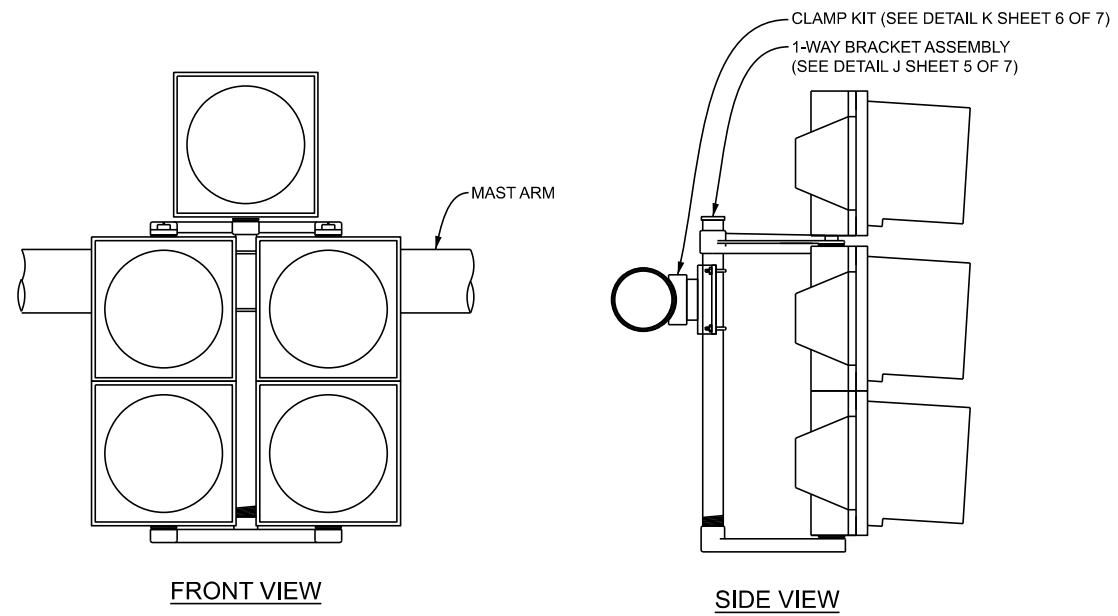

F DETAIL - 1W-5C (DOGHOUSE)
N.T.S.

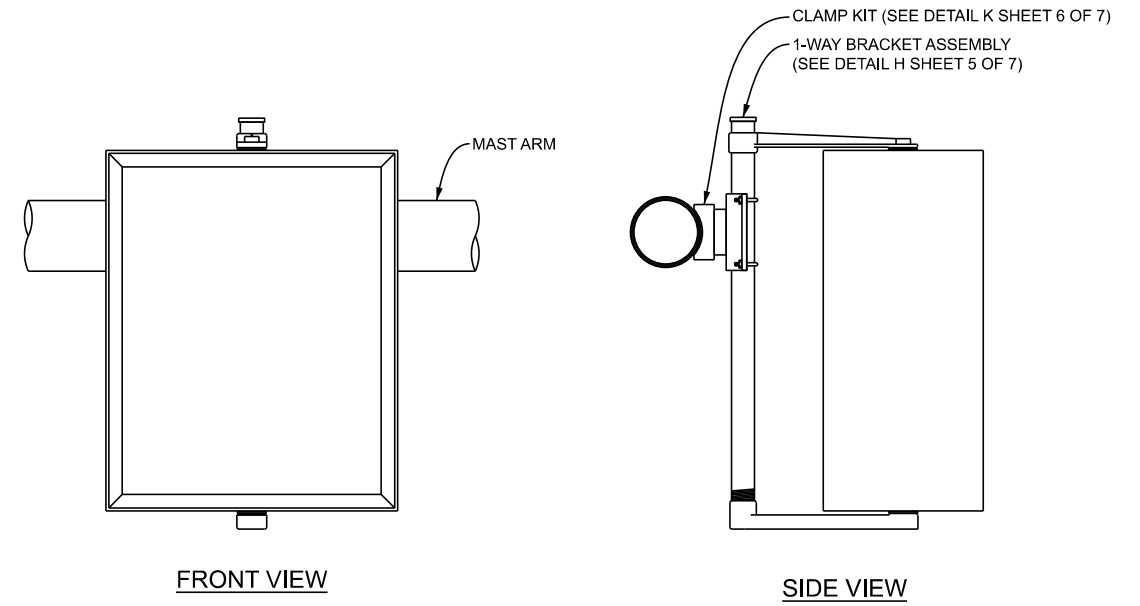

G DETAIL - 1W-CASE SIGN (24" X 30" SHOWN)
N.T.S.

APPROVED BY: _____ DIRECTOR, BUREAU OF FIELD SERVICES		STANDARD PLAN FOR MAST ARM MOUNTED T.S. BRACKET ASSEMBLY			
APPROVED BY: _____ DIRECTOR, BUREAU OF DEVELOPMENT		(SPECIAL DETAIL) FHWA APPROVAL	02/21/2024 PLAN DATE	SIG-301-A	SHEET 3 OF 7

	STANDARD PLAN FOR MAST ARM MOUNTED T.S. BRACKET ASSEMBLY			
	(SPECIAL DETAIL) FHWA APPROVAL	02/21/2024 PLAN DATE	SIG-301-A	SHEET 4 OF 7 SECT

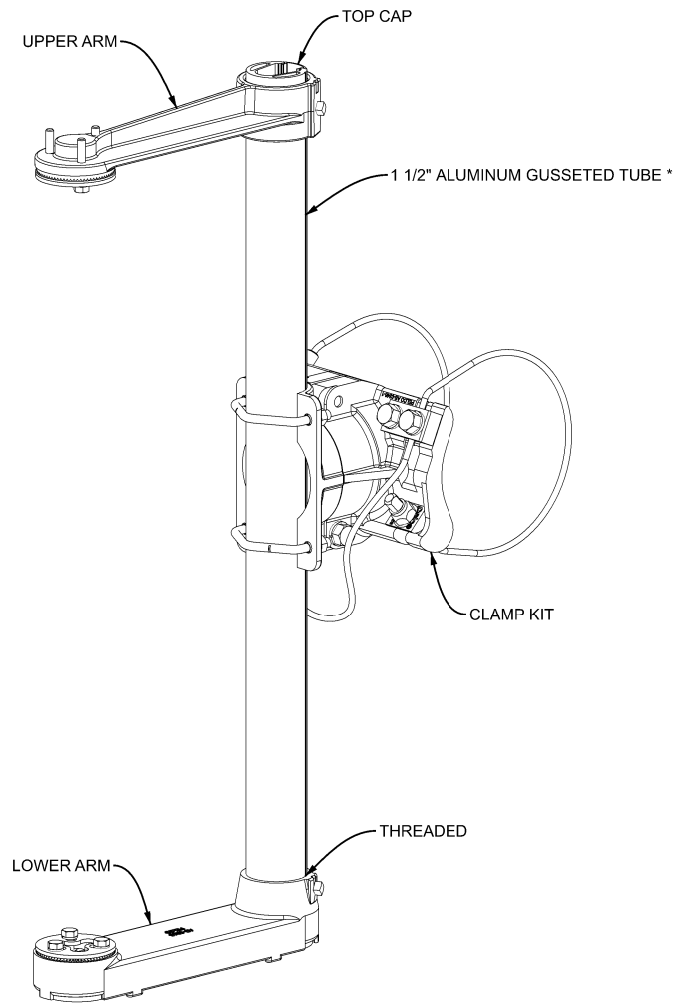

* NOTE:
USE 46\"/>

H DETAIL - 1-WAY BRACKET ASSEMBLY
N.T.S.

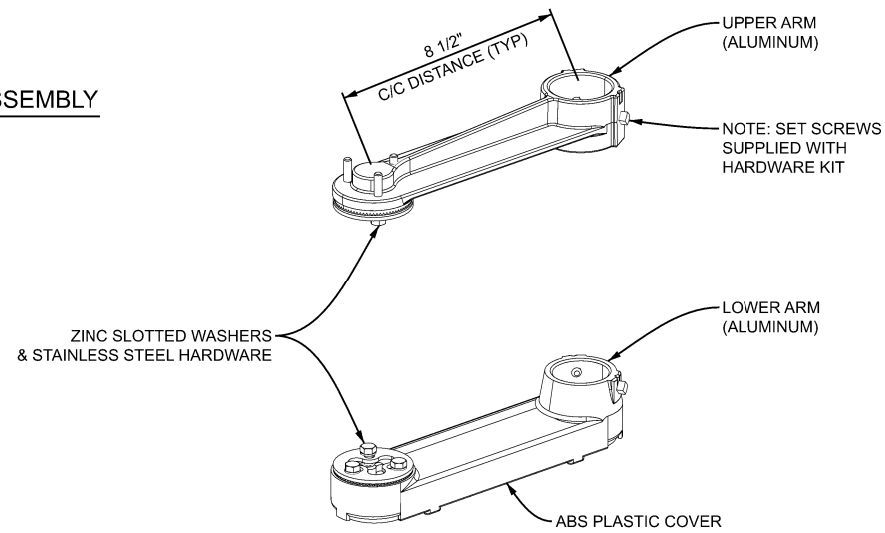

I DETAIL - 1-WAY BRACKET ARM ASSEMBLY
N.T.S.

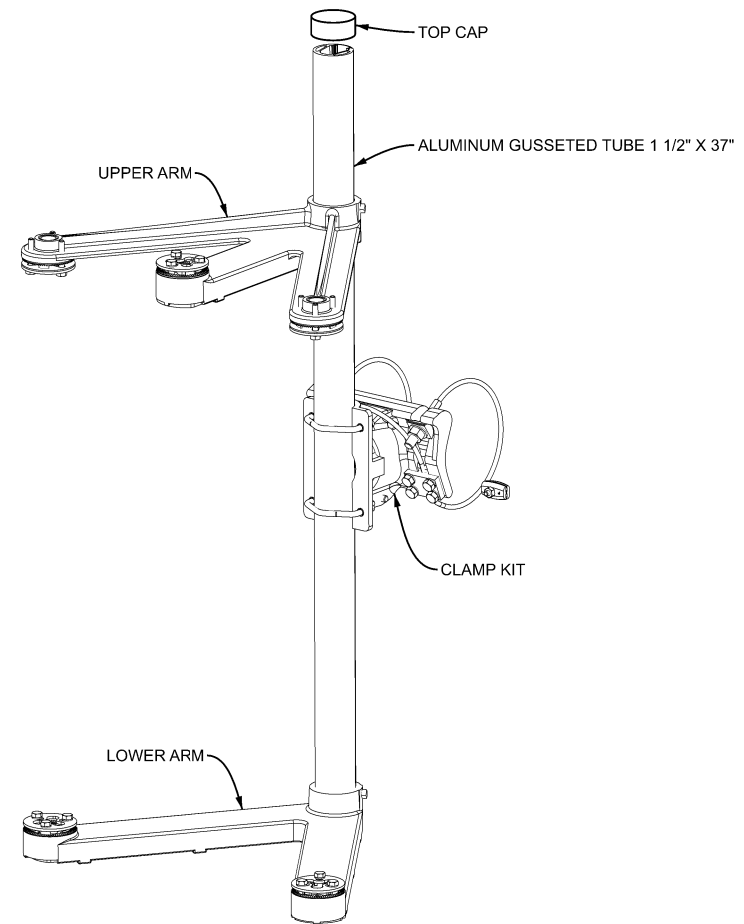

J DETAIL - 1-WAY 5-SECTION CLUSTER BRACKET ARM ASSEMBLY
N.T.S.

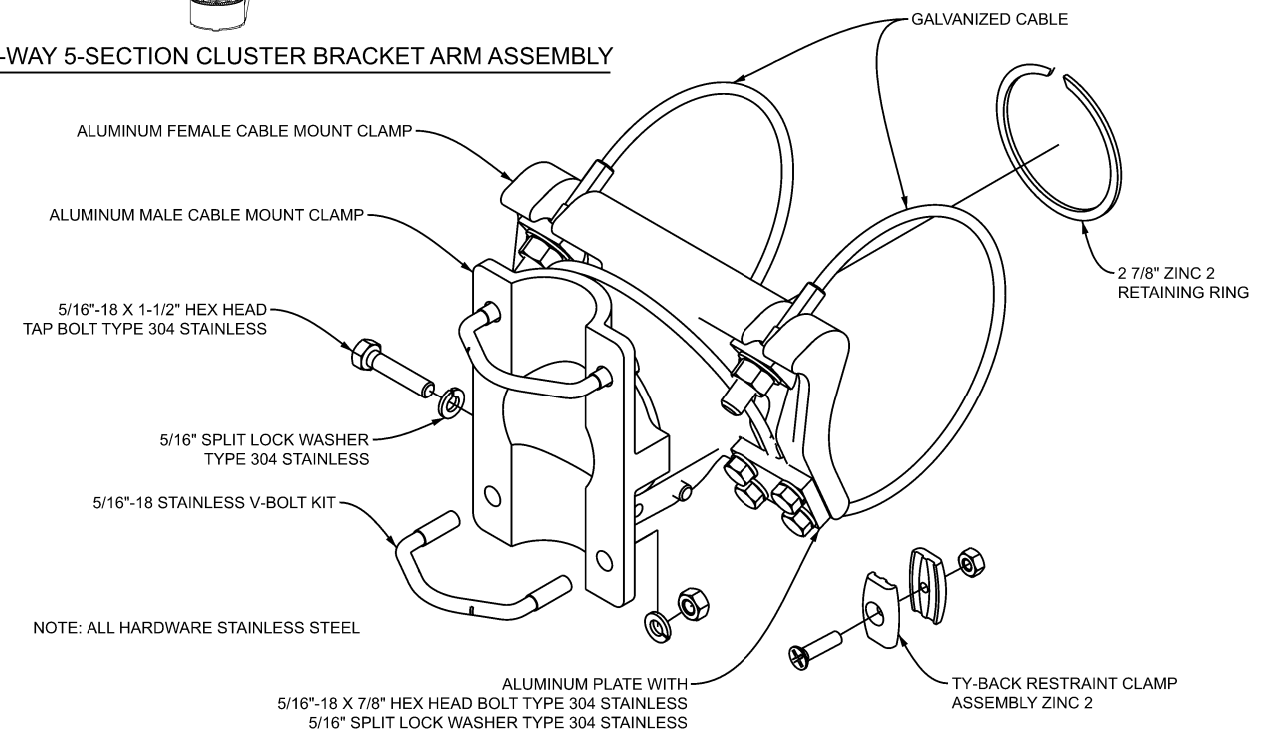

K DETAIL - ALUMINUM CLAMP WITH GALVANIZED CABLE
N.T.S.

APPROVED BY: _____
DIRECTOR, BUREAU OF FIELD SERVICES



DEPARTMENT DIRECTOR
BRADLEY C. WIEFERICH, PE

APPROVED BY: _____
DIRECTOR, BUREAU OF DEVELOPMENT

(SPECIAL DETAIL)
FHWA APPROVAL

02/21/2024
PLAN DATE

SIG-301-A

SHEET
5 OF 7



DEPARTMENT DIRECTOR
BRADLEY C. WIEFERICH, PE

(SPECIAL DETAIL)
FHWA APPROVAL

02/21/2024
PLAN DATE

SIG-301-A

SHEET
6 OF 7

SECT

STANDARD PLAN FOR
MAST ARM MOUNTED
T.S. BRACKET ASSEMBLY

STANDARD PLAN FOR
MAST ARM MOUNTED
T.S. BRACKET ASSEMBLY

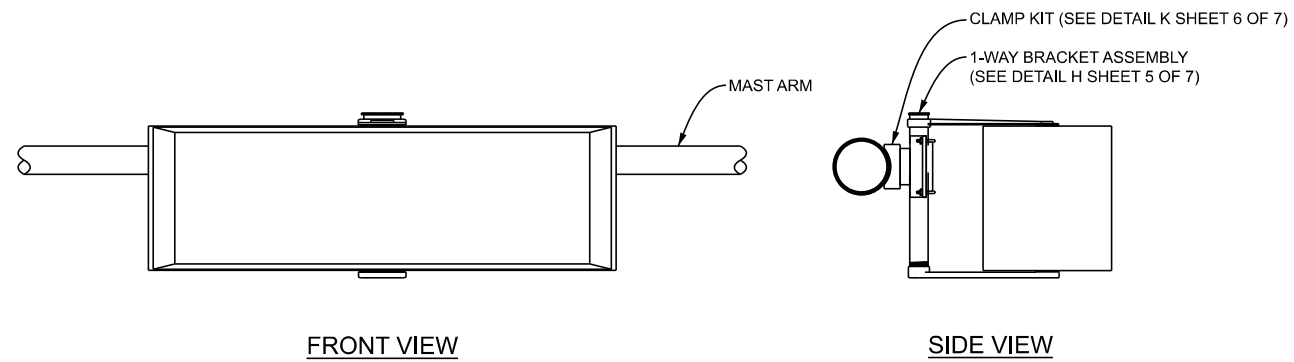

L DETAIL - 1W-ILLUMINATED STREET NAME SIGN
N.T.S.

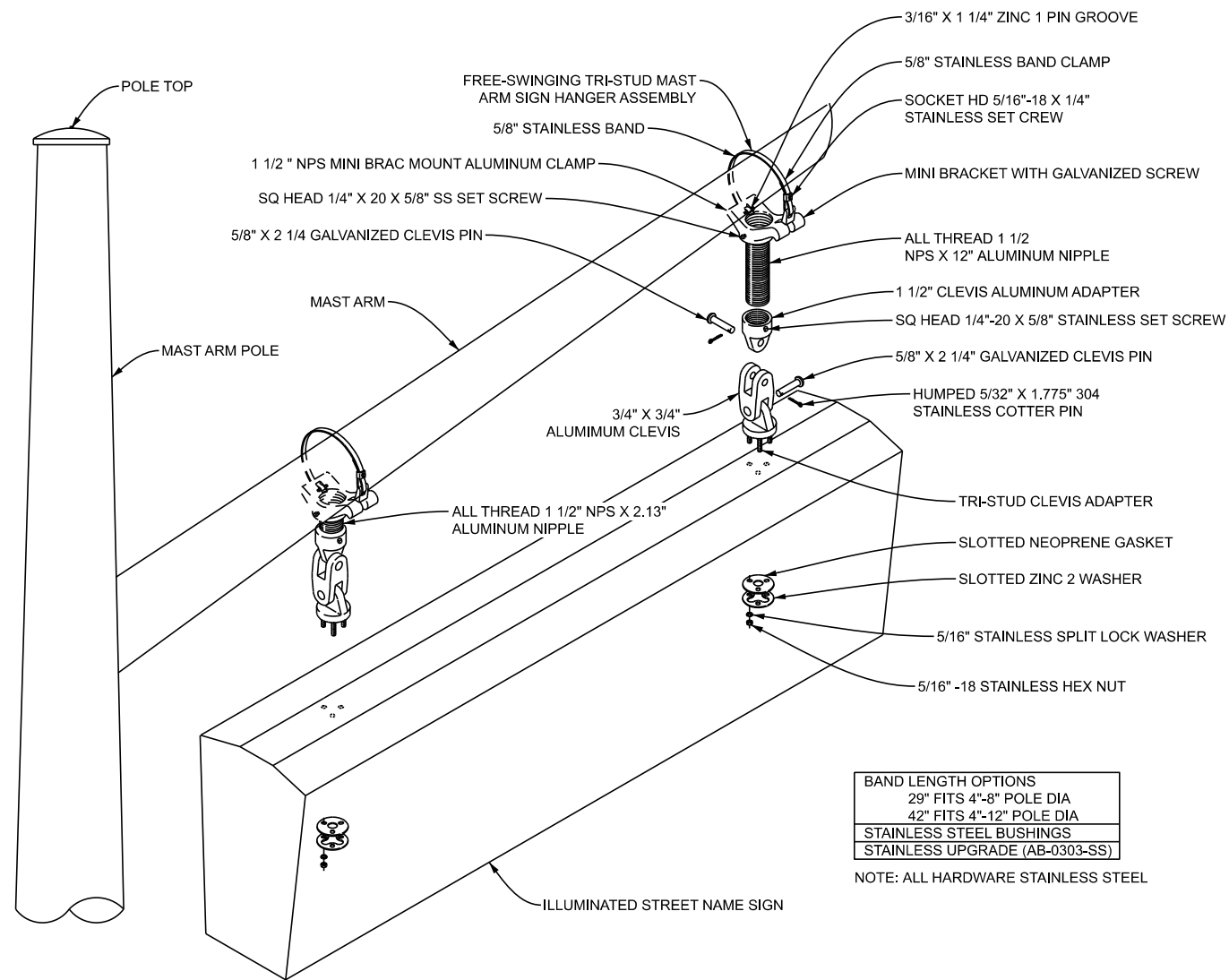

M DETAIL - 2W-ILLUMINATED STREET NAME SIGN
N.T.S.

APPROVED BY: _____ DIRECTOR, BUREAU OF FIELD SERVICES	<p>DEPARTMENT DIRECTOR BRADLEY C. WIEFERICH, PE</p>	STANDARD PLAN FOR MAST ARM MOUNTED T.S. BRACKET ASSEMBLY		
APPROVED BY: _____ DIRECTOR, BUREAU OF DEVELOPMENT		(SPECIAL DETAIL) FHWA APPROVAL	02/21/2024 PLAN DATE	SIG-301-A