

SECTION THRU BRIDGE

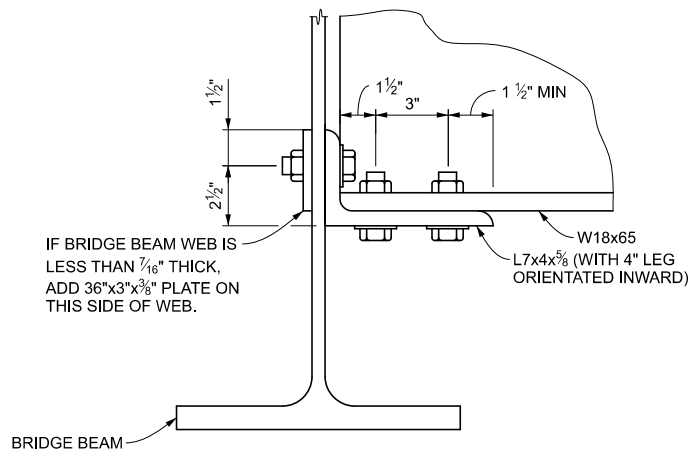

DETAIL D

(SHOWING ANGLES "IN" ORIENTATION)

APPROVED BY: _____
DIRECTOR, BUREAU OF FIELD SERVICES

APPROVED BY: _____
DIRECTOR, BUREAU OF DEVELOPMENT



DEPARTMENT DIRECTOR
BRADLEY C. WIEFERICH, PE

STANDARD PLAN FOR
BRIDGE SIGN CONNECTION TYPE F & G
(BB < 36")

(SPECIAL DETAIL)
FHWA APPROVAL

08/08/23
PLAN DATE

SIGN 820-C

SHEET
1 OF 8

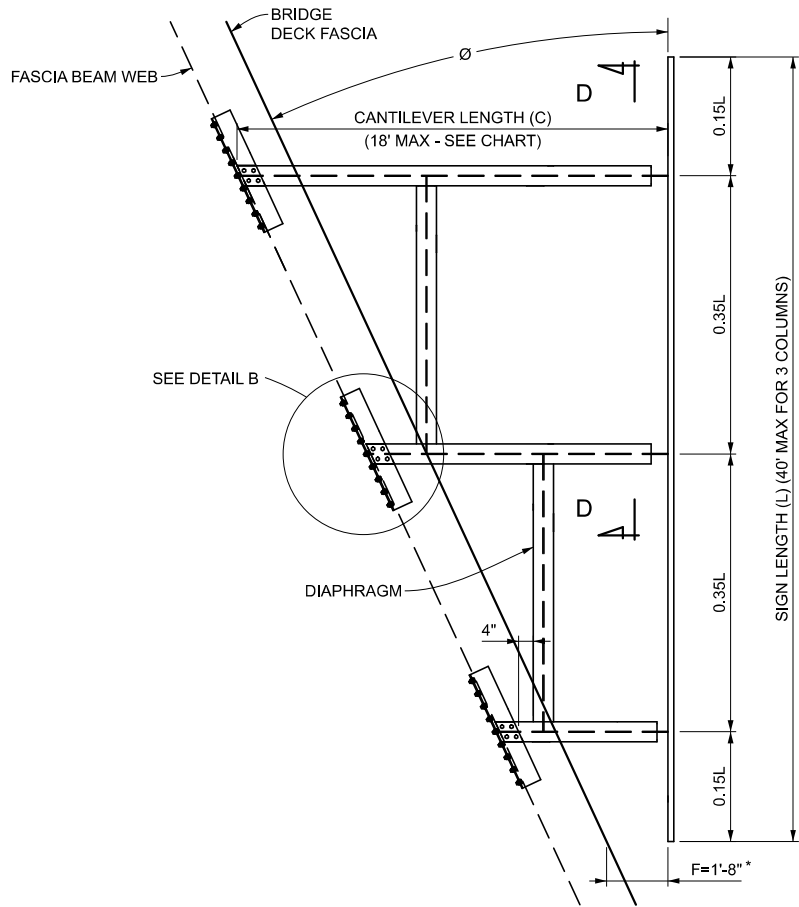

PLAN VIEW

TYPE G: 3 COLUMN SIGN CONNECTION

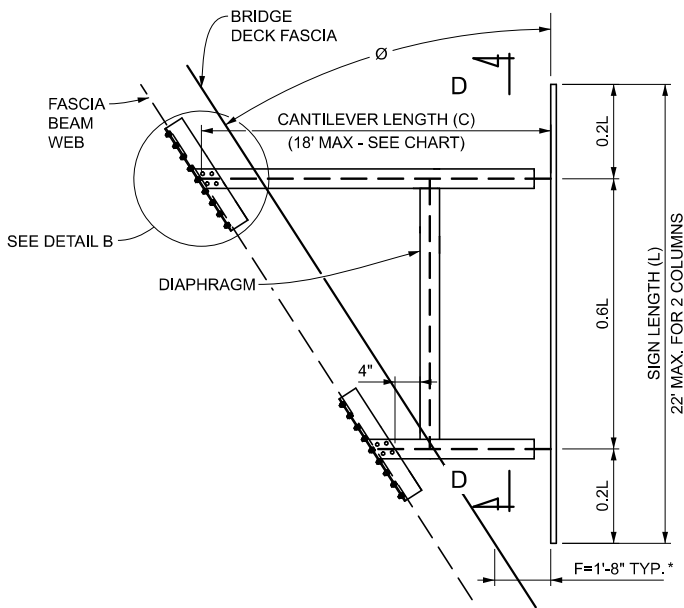

PLAN VIEW

TYPE F: 2 COLUMN SIGN CONNECTION

COLUMN	DIAPHRAGM REQUIRED
TYPE I	N/A
TYPE II	$C \geq 12'$
TYPE III	$C \geq 12'$

* 1'-8" DIMENSION MAY BE REDUCED TO 4" TO ACCOMMODATE LARGER SKEW θ ANGLES



DEPARTMENT DIRECTOR
BRADLEY C. WIEFERICH, PE

STANDARD PLAN FOR
BRIDGE SIGN CONNECTION TYPE F & G
(BB < 36")

(SPECIAL DETAIL)
FHWA APPROVAL

08/08/23
PLAN DATE

SIGN 820-C

SHEET
2 OF 8

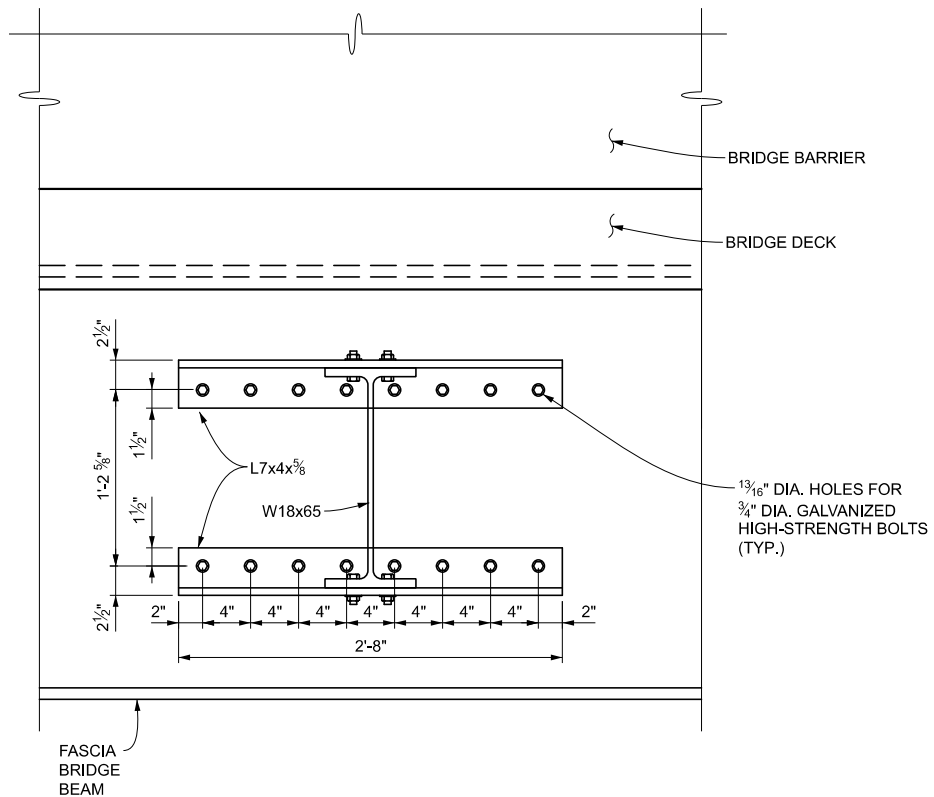

SECTION B-B
(SHOWING ANGLES "IN" ORIENTATION)

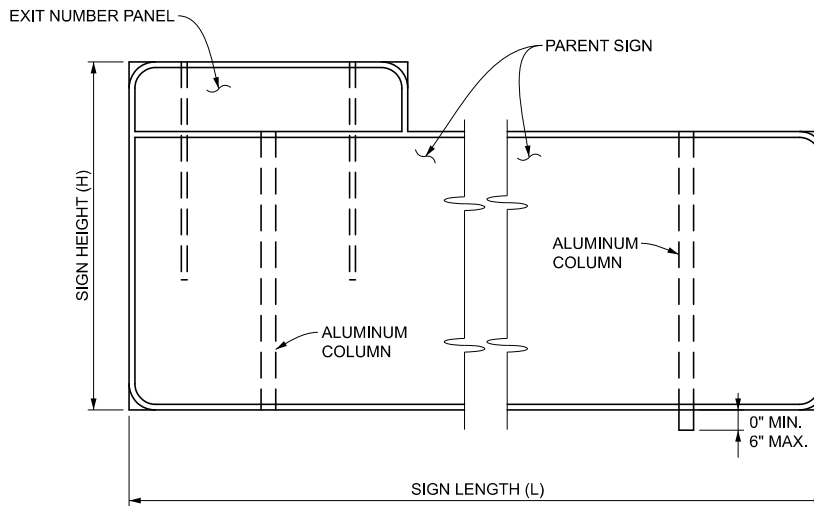

ELEVATION OF SIGN

NOTE:
SIGN HEIGHT IS MEASURED WHERE THE SIGN IS
THE TALLEST INCLUDING ANY EXIT NUMBER PANELS.



DEPARTMENT DIRECTOR
BRADLEY C. WIEFERICH, PE

STANDARD PLAN FOR
BRIDGE SIGN CONNECTION TYPE F & G
(BB < 36")

(SPECIAL DETAIL)
FHWA APPROVAL

08/08/23
PLAN DATE

SIGN 820-C

SHEET
4 OF 8

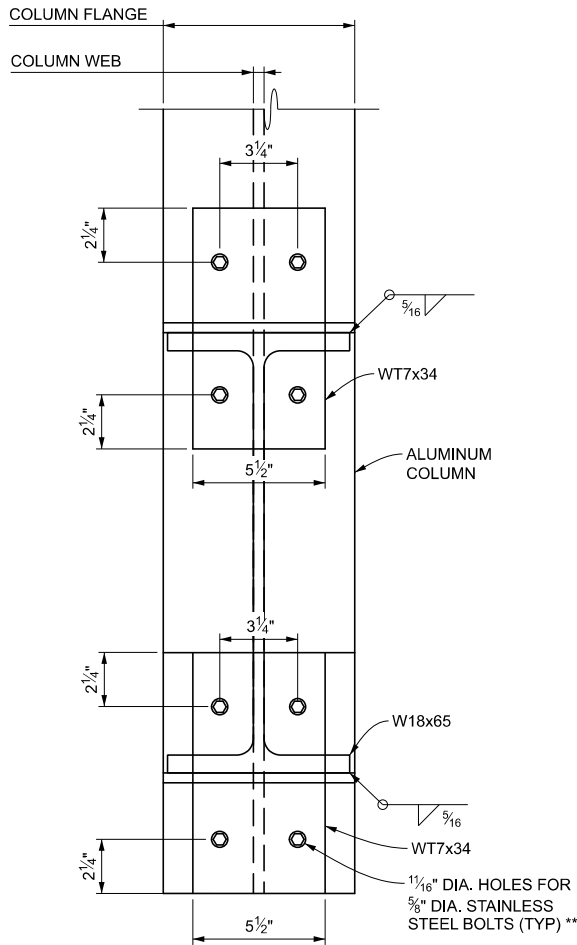

SECTION A-A

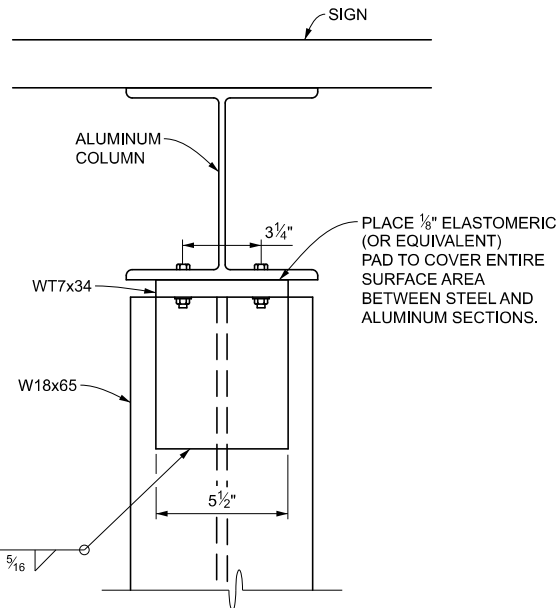

SECTION C-C

**SEE PAGE 3 OF 8 FOR BOLT DETAIL



DEPARTMENT DIRECTOR
BRADLEY C. WIEFERICH, PE

STANDARD PLAN FOR
BRIDGE SIGN CONNECTION TYPE F & G
(BB < 36")

(SPECIAL DETAIL)
FHWA APPROVAL

08/08/23
PLAN DATE

SIGN 820-C

SHEET
5 OF 8

ALUMINUM COLUMNS	
TYPE I	N/A
TYPE II	W8 x 10.7
TYPE III	W12 x 18.3
REF: ALUMINUM ASSOCIATION ALUMINUM DESIGN MANUAL, 2020 EDITION	

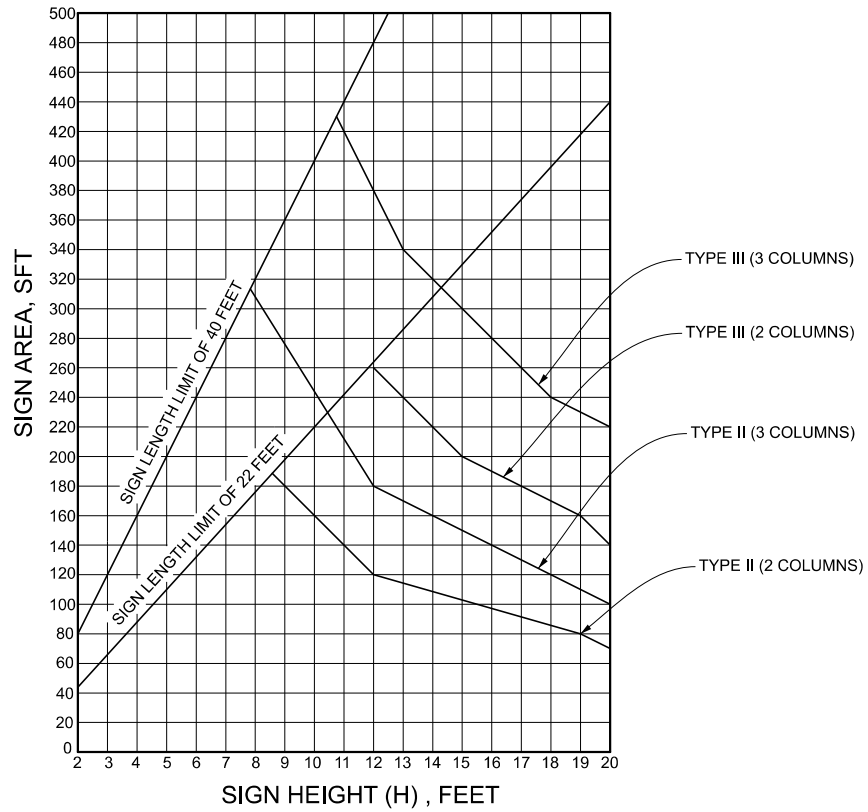

COLUMN SELECTION CHART

CHART USAGE

THE AMOUNT OF SKEW ANGLE (θ) THAT CAN BE TOLERATED IS DIRECTLY RELATED TO THE AMOUNT OF PERMISSIBLE CANTILEVER (C). THE CANTILEVER LENGTH IS CONTROLLED BY THE NUMBER OF COLUMNS USED AND THE SIGN AREA.

FOR EXAMPLE, USING A SIGN AREA OF 160 SQUARE FEET, A MAXIMUM CANTILEVER LENGTH OF 14 FEET IS ACHIEVABLE USING 3 COLUMNS, AND A MAXIMUM CANTILEVER LENGTH OF 10 FEET IS ACHIEVABLE USING 2 COLUMNS.

ALLOWABLE SIGN HEIGHT AND SIGN AREA ARE RELATED TO THE TYPE AND NUMBER OF ALUMINUM COLUMNS USED. FOR EXAMPLE, TO UTILIZE A SIGN AREA OF 160 SQUARE FEET, THE MAXIMUM SIGN HEIGHT ALLOWED IS 19' (2-TYPE III COLUMNS), 14' (3-TYPE II COLUMNS), 10' (2-TYPE II COLUMNS).

THE NUMBER OF COLUMNS TO BE USED IS A FUNCTION OF THE DESIRED SIGN AREA AND DESIRED CANTILEVER LENGTH. USE THE GREATER NUMBER OF COLUMNS AS DICTATED BY THE DESIRED SIGN AREA OR CANTILEVER LENGTH.

SKEW ANGLE (θ) IS A FUNCTION OF PERMISSIBLE CANTILEVER LENGTH (C) AND SIGN LENGTH (L). (REFER TO SIGN-840 SERIES).

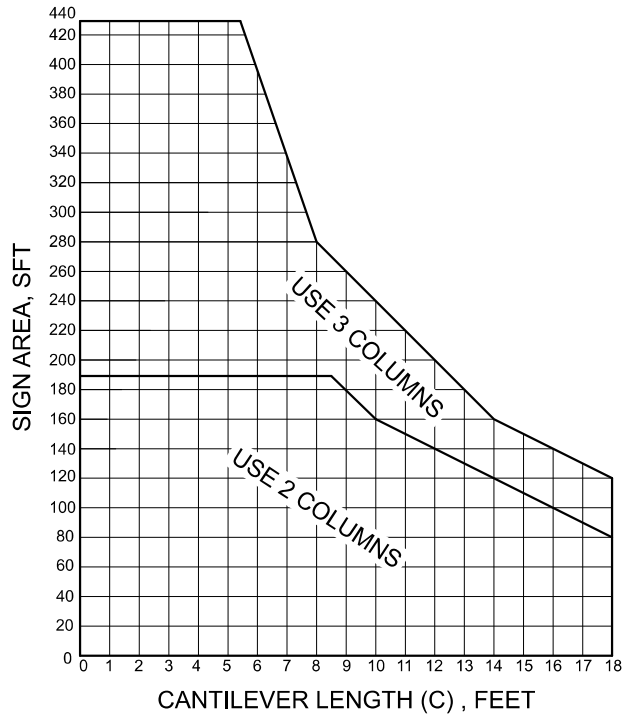

CANTILEVER LENGTH CHART (ANGLES IN)



DEPARTMENT DIRECTOR
BRADLEY C. WIEFERICH, PE

STANDARD PLAN FOR
BRIDGE SIGN CONNECTION TYPE F & G
(BB < 36")

(SPECIAL DETAIL)
FHWA APPROVAL

08/08/23
PLAN DATE

SIGN 820-C

SHEET
7 OF 8

NOTES:

1. FIELD VERIFY BRIDGE DIMENSIONS PRIOR TO FABRICATION.
2. WELDING SHALL BE IN ACCORDANCE WITH THE STANDARD SPECIFICATIONS FOR CONSTRUCTION.
3. ALL STRUCTURAL STEEL MEMBERS SHALL BE HOT-DIP GALVANIZED IN ACCORDANCE WITH THE STANDARD SPECIFICATIONS FOR CONSTRUCTION.
4. ALL ALUMINUM MEMBERS SHALL BE ASTM B 308 ALUMINUM ALLOY 6061 -T6 AND SHALL CONFORM TO ASTM B 221.
5. STRUCTURAL STEEL MEMBER SHALL CONFORM TO AASHTO M 270 GRADE 36 OR GRADE 50S.
6. ALL HIGH-STRENGTH BOLTS, NUTS AND WASHERS SHALL BE IN ACCORDANCE WITH SUBSECTION 906.07 AND INSTALLED ACCORDING TO SUBSECTION 707.03.E.6 OF THE STANDARD SPECIFICATIONS FOR CONSTRUCTION EXCEPT FOR STAINLESS STEEL BOLTS, NUTS AND WASHERS.
7. STAINLESS STEEL BOLTS AND WASHERS SHALL CONFORM TO ASTM A320, CLASS 1, GRADE B8. NUTS SHALL BE SELF-LOCKING NYLON INSERT TYPE AND MUST CONFORM TO ASTM A320, GRADE 8F. STAINLESS STEEL NUTS AND WASHERS SHALL ALWAYS ACCOMPANY STAINLESS STEEL BOLTS. STAINLESS STEEL BOLTS, NUTS AND WASHERS SHALL BE USED AT CONNECTIONS WITH ALUMINUM MEMBERS. ALL OTHER CONNECTIONS SHALL UTILIZE GALVANIZED HIGH-STRENGTH BOLTS, NUTS AND WASHERS UNLESS OTHERWISE SPECIFIED.
8. SIGN PANEL CONNECTIONS TO ALUMINUM COLUMNS SHALL HAVE THE SAME BOLT ARRANGEMENT AS SHOWN FOR SIGN PANEL CONNECTIONS TO ALUMINUM COLUMNS FOR CANTILEVER AND TRUSSES (SEE TYPICAL PLAN SIGN-700 SERIES).
9. THE BOTTOM EDGE OF THE SIGN SHALL BE HORIZONTAL WHEN ERECTED.
10. IF REPLACING AN EXISTING SIGN SUPPORT, UNUSED HOLES IN BRIDGE BEAMS SHALL BE FILLED WITH A GALVANIZED HIGH STRENGTH BOLT INSTALLED ACCORDING TO SUBSECTION 1005.02.B OF THE STANDARD SPECIFICATIONS FOR CONSTRUCTION.
11. SIGN LOCATION MAY BE SHIFTED TO AVOID JOINTS OR STIFFENERS, AS APPROVED BY THE ENGINEER.
12. FOR CONNECTIONS ON ASTM A588 WEATHERING STEEL BRIDGES, THE CONNECTION INTERFACE SHALL BE BLAST CLEANED AND PRIMED WITH ORGANIC ZINC-RICH PAINT IN ACCORDANCE WITH SECTION 715 OF THE STANDARD SPECIFICATIONS FOR CONSTRUCTION. IF THE EXISTING BRIDGE BEAM IS UNPAINTED ASTM A588 WEATHERING STEEL, THE PAINT COLOR SHALL BE "BROWN WEATHERING STEEL", FEDERAL CODE NUMBER 10062 AND THE PAINT SHALL OVERLAP THE PERIMETER OF THE CONNECTION BY 2 INCHES, OTHERWISE BLEND THE PAINT TO MATCH EXISTING PAINT COLOR. THE PERIMETER OF THE CONNECTIONS TO THE BRIDGE BEAM WEB SHALL BE SEALED WITH AN APPROVED SILICONE SEALANT IN ACCORDANCE WITH SUBSECTION 713.03.F OF THE STANDARD SPECIFICATIONS FOR CONSTRUCTION. THE BOLTED CONNECTIONS TO THE BRIDGE BEAM WEB SHALL BE ACCORDING TO SUBSECTION 1005.02.B OF THE STANDARD SPECIFICATIONS FOR CONSTRUCTION AND SHALL UTILIZE HIGH STRENGTH BOLTS CONFORMING TO ASTM A325 TYPE 3.
13. BRIDGES BUILT BEFORE 1978 CONTAIN LEAD BASED PAINT UNLESS REPAINTED AFTER 1978.
14. INSPECTION OF PROPOSED LOCATIONS SHALL BE PERFORMED TO DETERMINE VIABILITY OF CONNECTION TO EXISTING BRIDGE.
15. SEE SUBSECTION 810.03.P OF THE STANDARD SPECIFICATIONS FOR CONSTRUCTION FOR BOLT REPLACEMENT IN RETAINED BRIDGE MOUNTED SIGN CONNECTIONS.
16. REMOVAL OF THE EXISTING BRIDGE SIGN CONNECTIONS SHALL BE ACCORDING TO SUBSECTION 810.03.U OF THE STANDARD SPECIFICATION FOR CONSTRUCTION.
17. SEE SECTION 713 AND 715 OF THE STANDARD SPECIFICATION FOR CONSTRUCTION FOR BRIDGE SIGN CONNECTIONS TO EXISTING BRIDGES.
18. THE ENGINEER SHALL ANALYZE THE FASCIA BEAM WEB TO DETERMINE IF STIFFENERS OR IF A CROSS-FRAME IS NEEDED TO REINFORCE THE CONNECTION.
19. ALL MEMBERS ARE STEEL EXCEPT ALUMINUM COLUMNS.
20. THE DESIGN OF THIS BRIDGE SIGN CONNECTION IS ACCORDING TO THE AASHTO LRFD SPECIFICATIONS FOR STRUCTURAL SUPPORTS FOR HIGHWAY SIGNS, LUMINAIRES, AND TRAFFIC SIGNALS, FIRST EDITION (2015), WITH 2017 TO 2022 INTERIM REVISIONS.
21. θ = ANGLE BETWEEN SIGN AND BRIDGE FASCIA. ANGLE IS A FUNCTION OF PERMISSIBLE CANTILEVER (C) AND SIGN LENGTH (L). SEE SIGN-840 SERIES.

 DEPARTMENT DIRECTOR BRADLEY C. WIEFERICH, PE	STANDARD PLAN FOR BRIDGE SIGN CONNECTION TYPE F & G (BB < 36")			SIGN 820-C	SHEET 8 OF 8
	(SPECIAL DETAIL) FHWA APPROVAL	08/08/23 PLAN DATE			