

**STEEL STRAIN POLE**

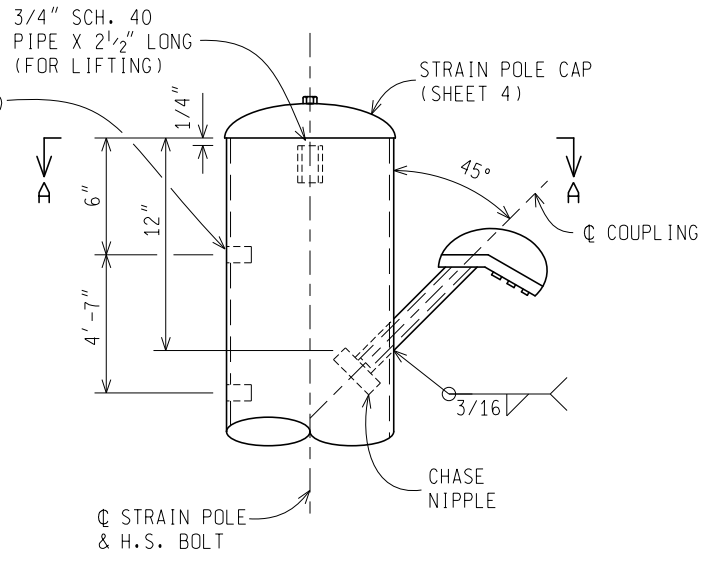

**DETAIL A**  
ORIENTATION OF 3" COUPLING 90° OR 270° FROM POLE HAND HOLE

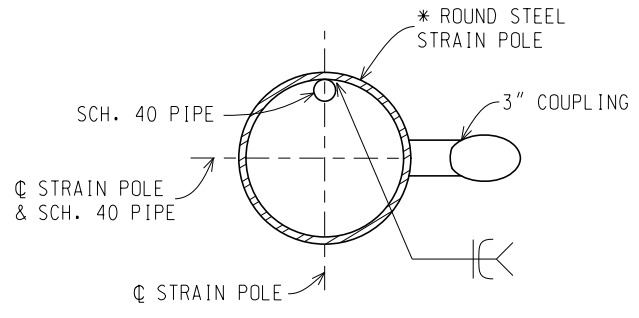

**SECTION A-A**  
SCH. 40 PIPE ORIENTED 180° TO POLE HAND HOLE  
\* SINGLE PLY SHOWN, BUT MULTI-PLY IS ALLOWED

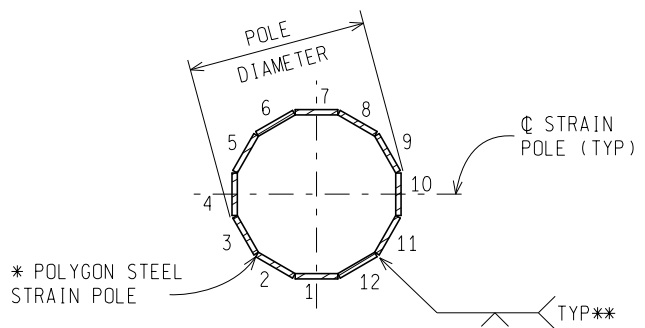

**OPTIONAL POLYGON CROSS SECTION**  
\* SINGLE PLY SHOWN, BUT MULTI-PLY IS ALLOWED  
\*\* LONGITUDINAL WELD JOINT

NOT TO SCALE

File: RefDoc/TR/Signals/Web/Sp Det/Fin/SIG020B.dgn Rev. 12/11/20

**MDOT**  
Michigan Department of Transportation

PREPARED BY  
TRAFFIC AND SAFETY

DRAWN BY:

CHECKED BY:

\_\_\_\_\_  
ENGINEER OF DELIVERY

\_\_\_\_\_  
ENGINEER OF DEVELOPMENT

(SPECIAL DETAIL)  
FHWA APPROVAL DATE

MICHIGAN DEPARTMENT OF TRANSPORTATION  
BUREAU OF HIGHWAYS DELIVERY STANDARD PLAN FOR

**6 ANCHOR BOLT  
STRAIN POLE AND FOUNDATION**

SIG-020-B

PLAN DATE

SHEET  
1 of 7

STRAIN POLE REQUIREMENTS					
POLE LENGTH (FT)		A	30 FT	36 FT	40 FT
MIN. POLE WALL THICKNESS (IN)		W	0.429	0.625	0.625
* POLE DIAMETER (IN)	AT TOP	B'	8 (MIN) ± 1/2	8 (MIN) ± 1/2	8 1/2 (MIN) ± 1/2
	AT BOTTOM	B	13 ± 1/2	13 ± 1/2	14 ± 1/2
FULL LENGTH TAPER (IN/FT)			+0.002 0.14 -0.000	+0.002 0.14 -0.000	+0.002 0.14 -0.000
POLE BASE FILLET WELD (IN)		E	5/16	1/2	1/2
POLE BASE LANDING (IN)		F	3/8	5/8	5/8
ANCHOR BOLT DIAMETER (IN)			1 1/2	1 3/4	1 3/4
ANCHOR BOLT HOLE DIAMETER (IN)			1 13/16	2 1/16	2 1/16
ANCHOR BOLT CIRCLE DIAMETER (IN)			18	21	21
ANCHOR BOLT CHORD (IN)		C	9	10 1/2	10 1/2
BASE PLATE EDGE (IN)		D	12 1/4	14 1/4	14 1/4
BASE PLATE THICKNESS (IN)		T	2	2 1/4	2 1/4
POLE BAND (SPAN CLAMP)		8 1/2"	P.O.C.H. 25'-6" TO 28'-6"	P.O.C.H. 32'-6" TO 34'-6"	P.O.C.H. 36'-0" TO 38'-6"
		9 1/2"	P.O.C.H. 20'-6" TO 25'-0"	P.O.C.H. 25'-0" TO 32'-0"	P.O.C.H. 29'-0" TO 35'-6"

\* DIAMETERS GIVEN ARE O.D.

**NOTES:**

1. THE DESIGN OF THIS STRUCTURE IS BASED ON THE AASHTO STANDARD SPECIFICATIONS FOR STRUCTURAL SUPPORTS FOR HIGHWAY SIGNS, LUMINAIRES AND TRAFFIC SIGNALS, FIFTH EDITION, 2009.
2. S.S. DENOTES STAINLESS STEEL. GA. DENOTES GAUGE. O.D. DENOTES OUTSIDE DIAMETER. I.D. DENOTES INSIDE DIAMETER. H.S. DENOTES HIGH STRENGTH. SCH. DENOTES SCHEDULE.
3. P.O.C.H. IS THE POINT OF CONTACT HEIGHT OF THE POLE BAND CLAMP FROM THE BOTTOM OF THE STRAIN POLE.

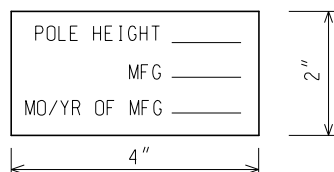

**STRAIN POLE STAINLESS STEEL ID TAG DETAIL**

TO BE ATTACHED TO STRAIN POLE AT LOCATIONS SHOWN 4" FROM BASE OF TUBE BELOW HANDHOLE WITH (4) #8 X 3/8" S.S. TYPE U DRIVE SCREWS. (LETTERS STAMPED IN 3/8" CHARACTERS)

NOT TO SCALE

MICHIGAN DEPARTMENT OF TRANSPORTATION BUREAU OF HIGHWAYS DELIVERY STANDARD PLAN	FHWA APPROVAL DATE	PLAN DATE	SIG-020-B	SHEET 2 of 7
File:RefDoc/TR/Signals/Web/Sp Det/Fin/SIG020B.dgn Rev. 12/11/20				

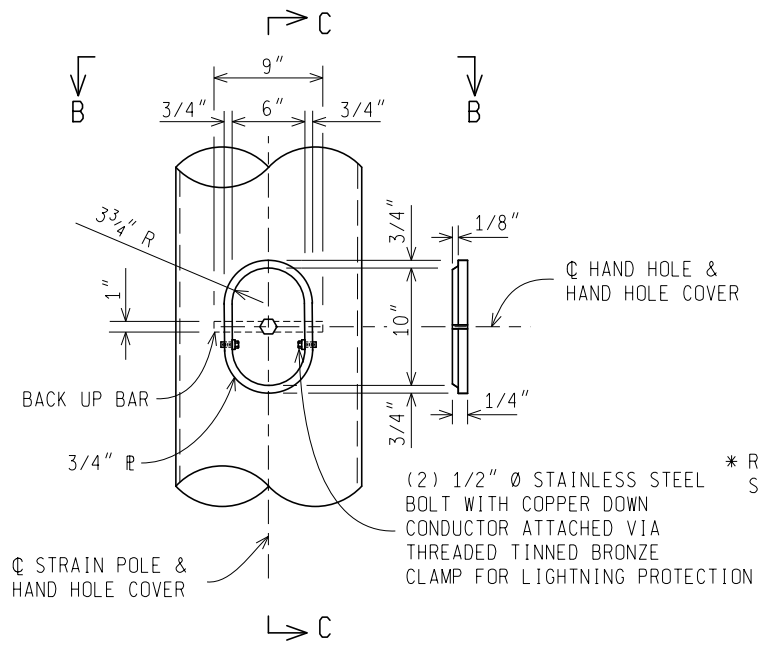

**HAND HOLE DETAIL**

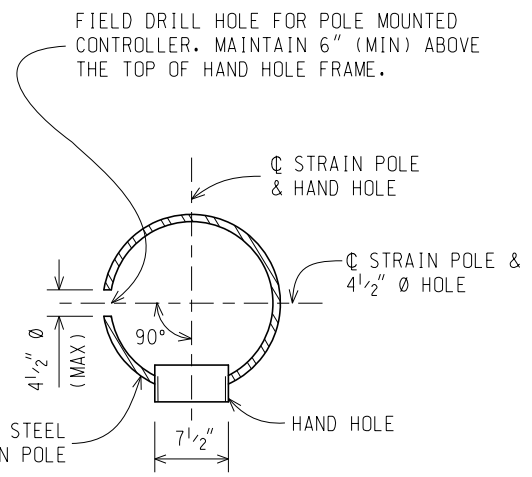

**SECTION B-B**

SEE ORIENTATION OF STRAIN POLE BELOW  
 \* SINGLE PLY SHOWN, BUT MULTI-PLY IS ALLOWED

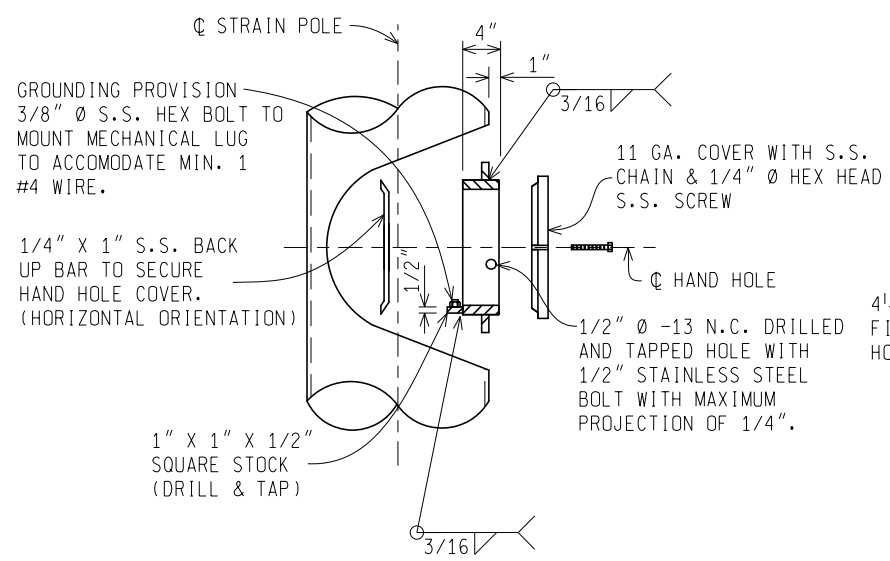

**SECTION C-C**

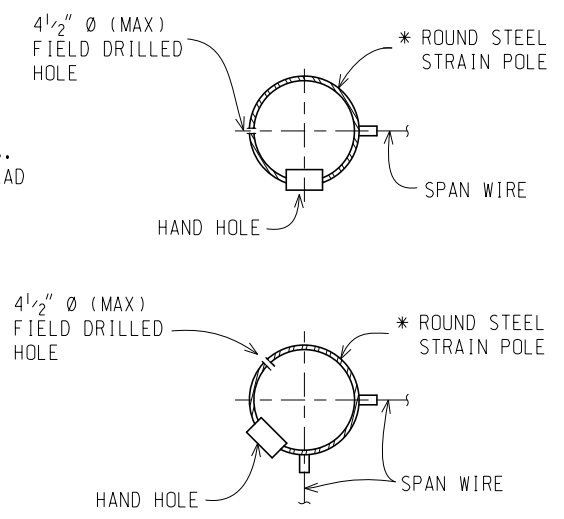

**STRAIN POLE ORIENTATION**

\* SINGLE PLY SHOWN, BUT MULTI-PLY IS ALLOWED

NOT TO SCALE

MICHIGAN DEPARTMENT OF TRANSPORTATION BUREAU OF HIGHWAYS DELIVERY STANDARD PLAN	FHWA APPROVAL DATE		SIG-020-B	SHEET 3 of 7
File:RefDoc/TR/Signals/Web/Sp Det/Fin/SIG020B.dgn	Rev. 12/11/20	PLAN DATE		

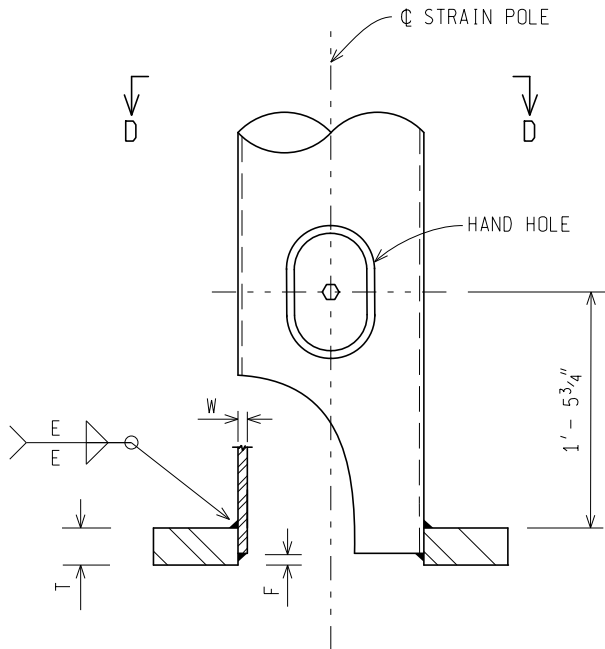

**DETAIL B**

ANCHOR BOLTS NOT SHOWN FOR CLARITY

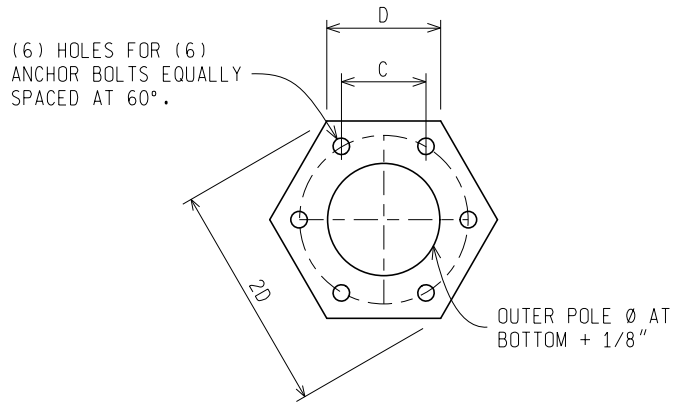

**SECTION D-D - BASE PLATE**

SEE CHART ON PAGE 2 FOR ANCHOR BOLT CIRCLE Ø, ANCHOR BOLT HOLE Ø, AND ANCHOR BOLT Ø. (STRAIN POLE NOT SHOWN FOR CLARITY)

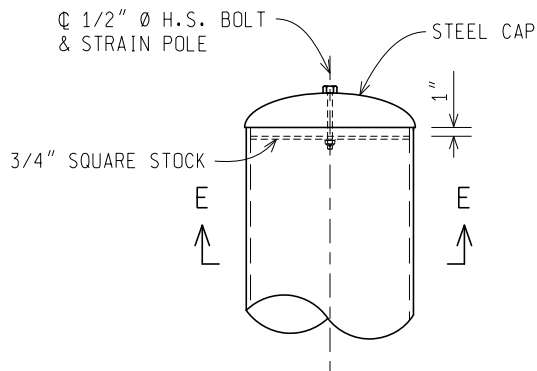

**STRAIN POLE CAP DETAIL**

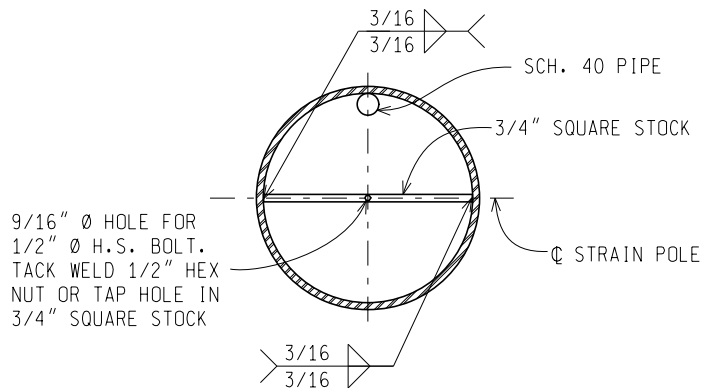

**SECTION E-E**

NOT TO SCALE

STRAIN POLE FOUNDATION REQUIREMENTS				
POLE LENGTH (FT)	30 FT		36 FT	40 FT
ANCHOR BOLT DIAMETER (IN)	1½	1¾	1¾	1¾
ANCHOR BOLT CIRCLE DIAMETER (IN)	18	21	21	21
ANCHOR BOLT LENGTH (IN)	72		72	72
FOUNDATION DIAMETER (IN)	36	42	42	42

**NOTES:**

- ALL WORK AND MATERIALS MUST BE IN ACCORDANCE WITH THE MDOT STANDARD SPECIFICATIONS FOR CONSTRUCTION. CONSTRUCT STRAIN POLE FOUNDATIONS ACCORDING TO SECTION 718.03 OF THE MDOT STANDARD SPECIFICATIONS FOR CONSTRUCTION.
- IF SOIL CONDITIONS INDICATE THERE IS NO NEED FOR A CASING PAY ITEM AS SHOWN ON THE PLANS. THE CONTRACTOR SHALL REQUEST PERMISSION OF THE ENGINEER TO INSTALL THE FOUNDATION WITHOUT CASING.
- WHEN THE CASING PAY ITEM IS INCLUDING ON THE PLANS FOR A FOUNDATION (DUE TO GRANULAR SOILS OR A WET HOLE), STEEL CASING (SMOOTH WALLED) IS TO BE INSTALLED TO ENABLE THE FOUNDATION TO BE POURED. THE THICKNESS OF THE STEEL CASING IS TO BE DETERMINED BY THE CONTRACTOR. THE STEEL MUST BE LEFT IN PLACE. SMOOTH WALLED STEEL CASING OUTSIDE DIAMETER TO MEET OR EXCEED FOUNDATION DIAMETER. A SUITABLE METHOD OF COMPACTION MUST BE EMPLOYED TO ENSURE THE SOIL IMMEDIATELY OUTSIDE THE CASING IS COMPACTED PROPERLY.
- WHEN THE CASING PAY ITEM IS CALLED FOR ON THE PLANS, THE STEEL CASING MAY STOP AT THE CONDUIT ENTRANCE TO FOUNDATION. TOP OF FOUNDATION MUST THEN BE FORMED SEPARATELY, EVEN THOUGH THE STEEL CASING STOPS AT THE CONDUIT ENTRANCE. THE CASING PAY ITEM QUANTITY WILL BE PAID FOR BASED ON ACTUAL LINEAR FEET INSTALLED.
- DEWATERING OF WET SHAFTS IS NOT ALLOWED. A WET SHAFT IS DEFINED AS HAVING MORE THAN 3" OF STANDING WATER OR AS HAVING WATER INFILTRATING AT A RATE EQUAL TO OR EXCEEDING 12" PER HOUR. FOR WET SHAFTS, CONCRETE IS TO BE PLACED IN ACCORDANCE WITH SECTION 705 (WET CONSTRUCTION METHOD) WITH A TREMIE TUBE OR CONCRETE PUMP BEGINNING AT THE SHAFT BOTTOM. GRADE T CONCRETE MUST BE USED FOR UNDERWATER PLACEMENT. GRADE S2 MAY BE USED IN DRY EXCAVATIONS ONLY. SEE MDOT STANDARD SPECIFICATIONS TABLE 701-1 (CONCRETE STRUCTURE MIXTURES)
- PER MDOT STANDARD SPECIFICATIONS 718.02, THE GRADE S2 ACCEPTABLE SLUMP RANGE IS 4-6 INCHES THE GRADE T ACCEPTABLE SLUMP RANGE IS 8-10 INCHES.
- CONSTRUCT STRAIN POLE FOUNDATIONS, CASSED OR UNCASSED, ACCORDING TO SUBSECTION 810.03.J AND 705 OF THE STANDARD SPECIFICATIONS FOR CONSTRUCTION. ALL WORK AND MATERIALS MUST BE IN ACCORDANCE WITH THE MDOT STANDARD SPECIFICATION FOR CONSTRUCTION.
- STEEL REINFORCEMENT MUST CONFORM TO SECTION 921 OF THE MDOT STANDARD SPECIFICATIONS FOR CONSTRUCTION.
- EXPOSED CONCRETE SURFACES MUST BE CAST IN FORMS
- STEEL REINFORCEMENT MUST HAVE A CLEAR COVER OF 3.00 INCHES UNLESS OTHERWISE NOTED. STEEL REINFORCEMENT MAY BE ADJUSTED TO ENSURE PROPER CLEAR COVER.
- CONDUITS AND ANCHOR BOLTS MUST BE RIGIDLY INSTALLED BEFORE CONCRETE IS PLACED. ANCHOR BOLTS MUST BE SPACED BY MEANS OF A TEMPLATE. THE CENTER OF THE TEMPLATE MUST COINCIDE WITH THE CENTER OF THE FOUNDATION.
- GROUNDING OF POLE INCLUDES ADDING #4 BARE COPPER GROUND WIRE BONDED BY LISTED MECHANICAL CONNECTION TO FOUNDATION REINFORCING STEEL AND HAVING 24" OF SLACK ABOVE THE TOP OF FOUNDATION.
- INSTALL COPPER CLAD GROUND ROD(S) AS DIRECTED BY ENGINEER AND IN ACCORDANCE WITH CURRENT N.E.C. ALL GROUNDS MUST PROVIDE LESS THAN 10 OHM RESISTANCE TO GROUND.
- REFER TO THE FOLLOWING SPECIAL PROVISIONS FOR 6 ANCHOR BOLT STRAIN POLES:  
 STEEL STRAIN POLE  
 STRAIN POLE FOUNDATION AND ANCHOR BOLTS  
 CASING USED WITH STRAIN POLES AND MAST ARM POLES

NOT TO SCALE

MICHIGAN DEPARTMENT OF TRANSPORTATION BUREAU OF HIGHWAYS DELIVERY STANDARD PLAN	FHWA APPROVAL DATE		SIG-020-B	SHEET 5 of 7
File:RefDoc/TR/Signals/Web/Sp Det/Fin/SIG020B.dgn	Rev. 12/11/20	PLAN DATE		

(8) A08 BARS (36" Ø FOUNDATION)  
OR (8) A09 BARS (42" Ø FOUNDATION)  
EQUALLY SPACED

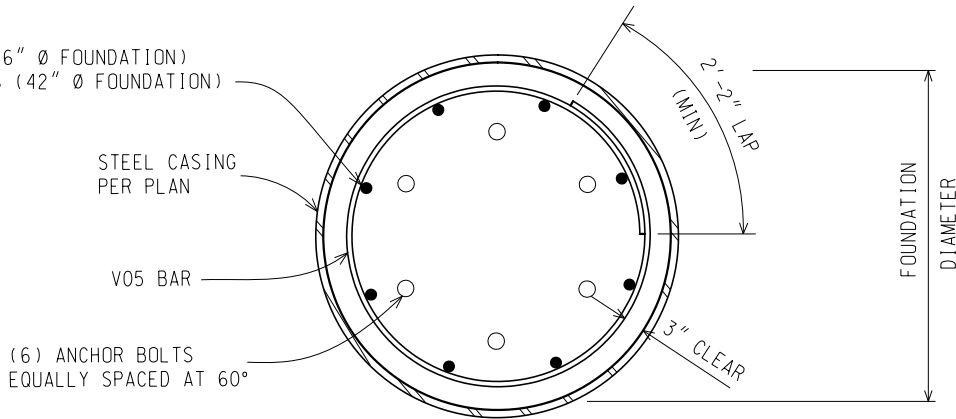

### PLAN VIEW - FOUNDATION DETAIL

SEE CHART ON PAGE 5 FOR ANCHOR BOLT CIRCLE Ø,  
ANCHOR BOLT Ø, AND FOUNDATION Ø.

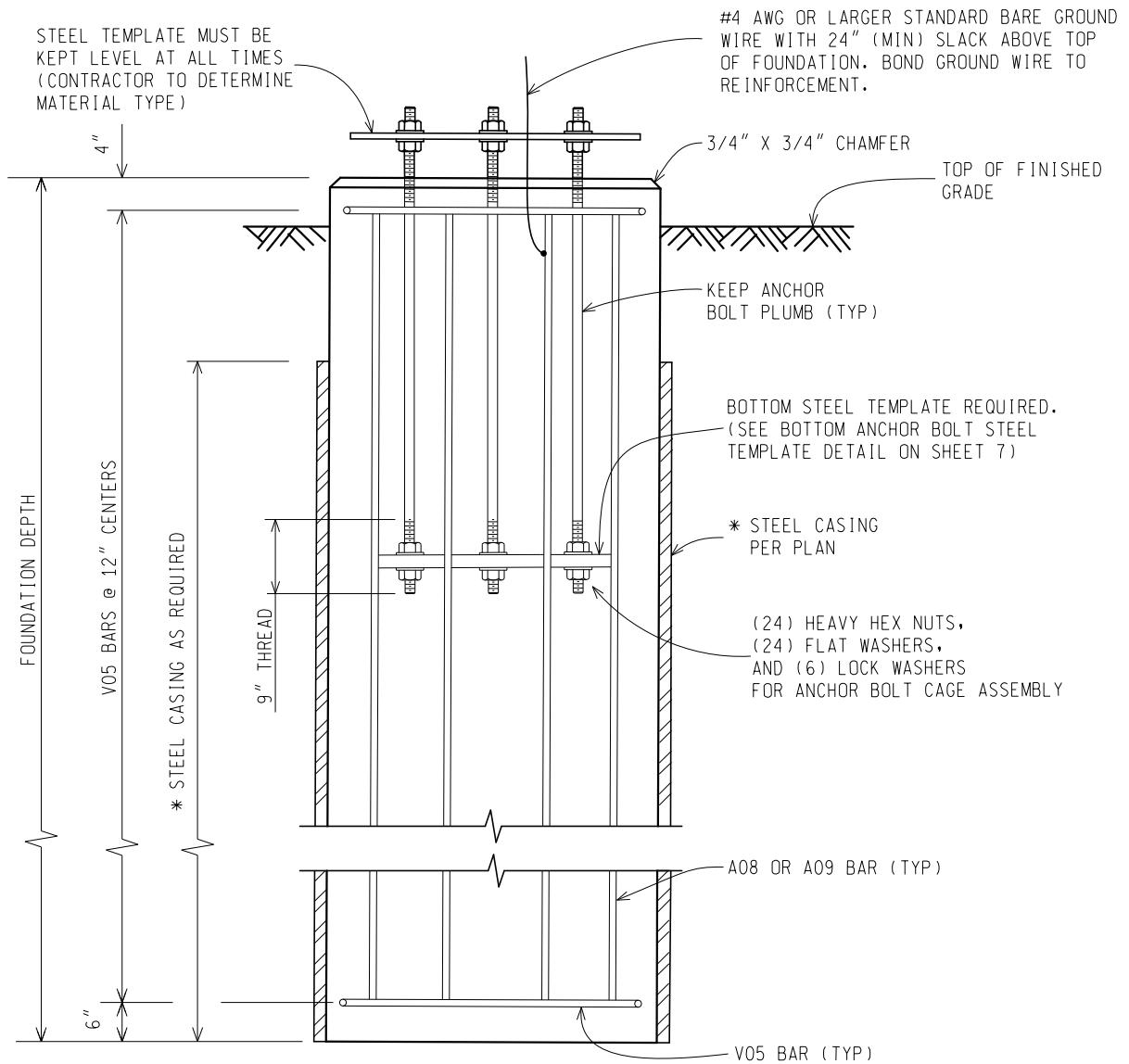

### ELEVATION VIEW - FOUNDATION DETAIL

\* SEE FOUNDATION NOTES AND PLANS FOR STEEL CASING PAY ITEM

NOT TO SCALE

MICHIGAN DEPARTMENT OF TRANSPORTATION  
BUREAU OF HIGHWAYS DELIVERY STANDARD PLAN

FHWA APPROVAL DATE

PLAN DATE

SIG-020-B

SHEET  
6 of 7

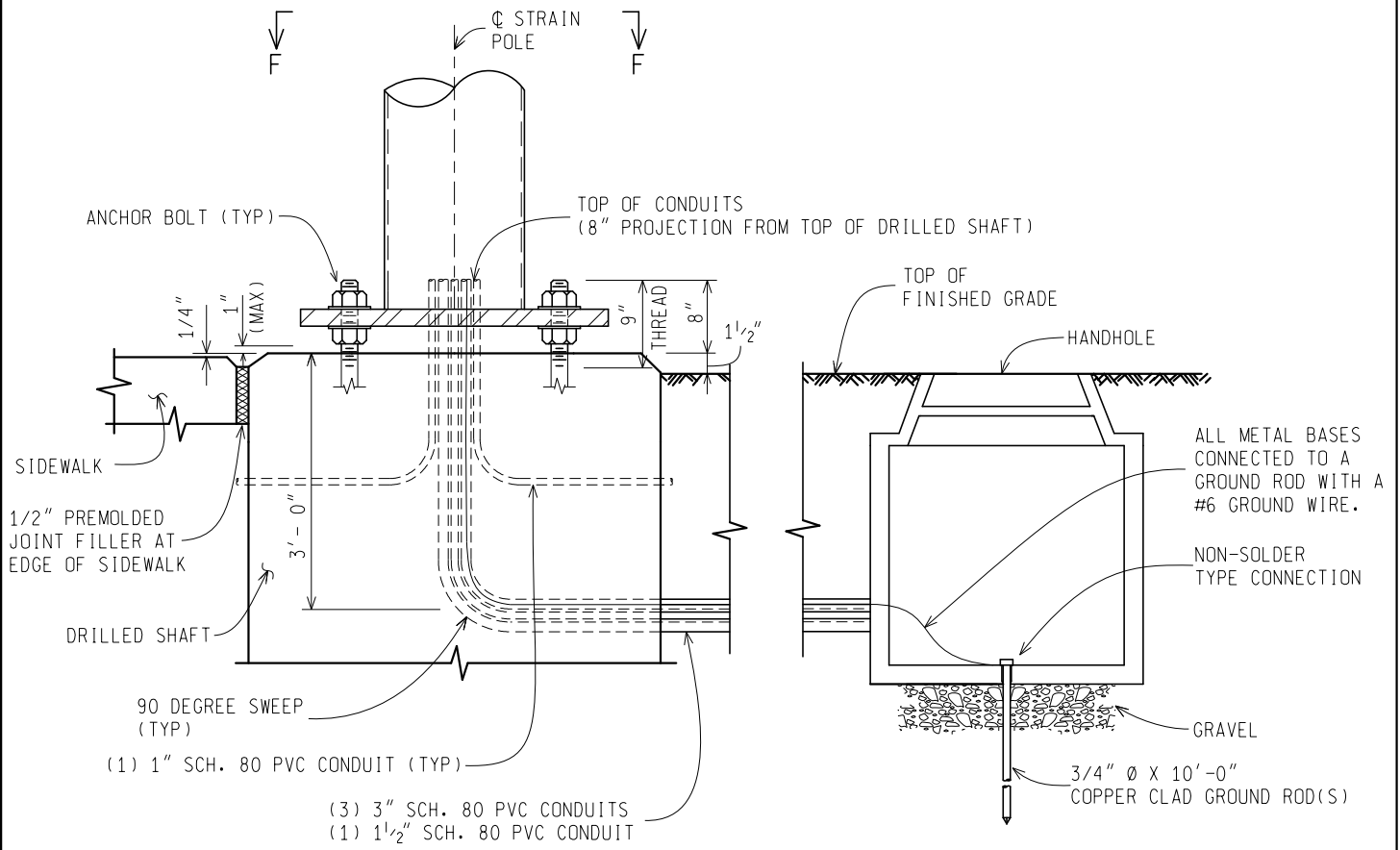

### CONDUIT LAYOUT

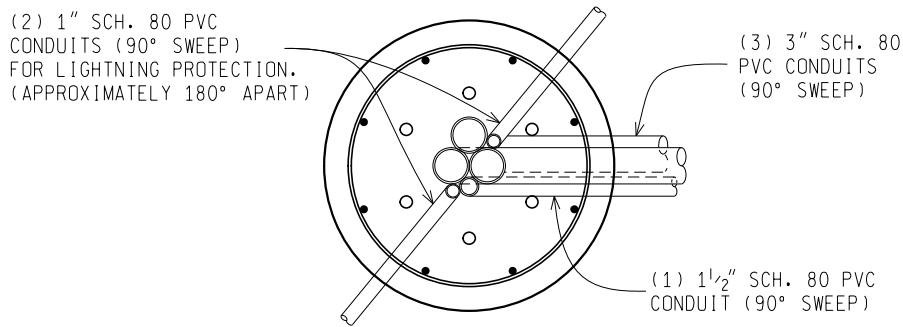

### SECTION F-F

SECURE CONDUITS TOGETHER WITH SUITABLE BANDING TO ENSURE PLACEMENT PRIOR TO CONCRETE POUR.

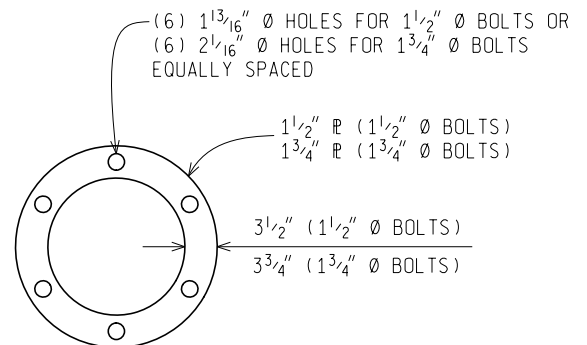

### BOTTOM ANCHOR BOLT STEEL TEMPLATE DETAIL

SEE CHART ON PAGE 5 FOR ANCHOR BOLT CIRCLE Ø, ANCHOR BOLT HOLE Ø, AND FOUNDATION Ø

NOT TO SCALE

MICHIGAN DEPARTMENT OF TRANSPORTATION  
BUREAU OF HIGHWAYS DELIVERY STANDARD PLAN

FHWA APPROVAL DATE

PLAN DATE

SIG-020-B

SHEET  
7 of 7