

(For use with 35 ft and 40 ft cantilever arms)
 * Or as required by the engineer.

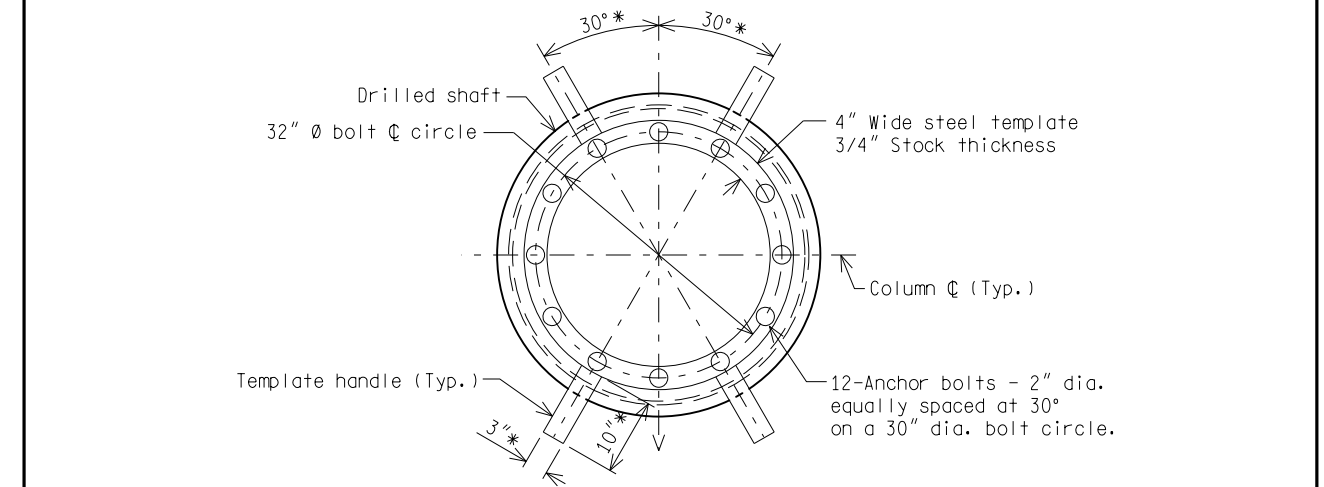

(For use with 20 ft through 30 ft cantilever arms or with 35 ft and 40 ft cantilever arms with reduced sign area (see chart on sheet 5).
 * Or as required by the engineer.

DRILLED SHAFT FOR TYPE J CANTILEVERS

<p>PREPARED BY ANCILLARY STRUCTURES</p> <p>DRAWN BY: <u>HNTB</u></p> <p>CHECKED BY: <u>MLD</u></p>	<p>DEPARTMENT DIRECTOR Paul C. Ajegba</p> <p>APPROVED BY: _____ DIRECTOR, BUREAU OF FIELD SERVICES</p>	<p>MICHIGAN DEPARTMENT OF TRANSPORTATION</p> <p>DRILLED SHAFT FOUNDATION FOR CANTILEVER TYPE J</p>		
	<p>APPROVED BY: _____ DIRECTOR, BUREAU OF DEVELOPMENT</p>	<p>(SPECIAL DETAIL) F.H.W.A. APPROVAL</p>	<p>08/08/23 PLAN DATE</p>	<p>SIGN-350-C</p>

NOT TO SCALE		MICHIGAN DEPARTMENT OF TRANSPORTATION		(SPECIAL DETAIL) F.H.W.A. APPROVAL	08/08/23 PLAN DATE	SIGN-350-C	SHEET 2 OF 6
--------------	--	---------------------------------------	--	---------------------------------------	-----------------------	------------	-----------------

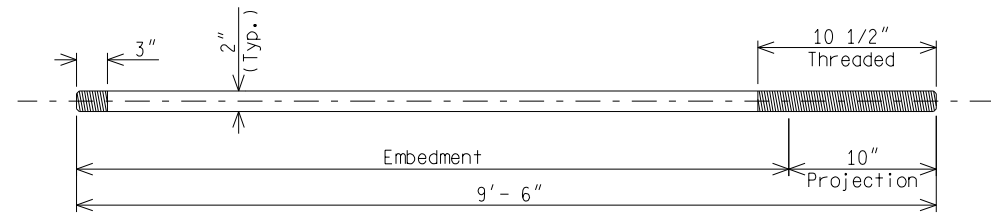

ANCHOR BOLT DETAIL

16 Anchors required. Provide 3 nuts and 3 washers per anchor bolt.

NOTES:

1. Steel reinforcement must be per MDOT Standard Specifications for Construction.
2. Anchor bolts, nuts, and washers must be per section 908.14 of the MDOT Standard Specifications for Construction.
3. Diameter of bolt holes in template must be 1/16" larger than anchor bolt diameter.
4. The template and handles must be well supported, horizontally level and firmly anchored in place a minimum of 24 hours after concrete placement is complete.
5. During concrete placement, avoid displacing the anchor bolts. Concrete must be in accordance with MDOT Standard Specifications For Construction, Subsection 810.03.J.
6. Hammering on the anchor bolts or template will not be allowed.
7. After template is removed, thread nuts on to bolt flush with the bolt end to protect threads until sign support is erected.

NOT TO SCALE

Steel Bar Reinforcement Chart

Structure Type	Foundation Diameter (in)	Vertical Reinforcement		Confinement Reinforcement		
		Bar Size	Number of Bars	Bar Radius	Bar Size	Bar Spacing
Type J Cantilever	48	11	36	20 1/4"	6	5"
	60	11	63	26 1/4"	6	5"
	72	11	57	32 1/4"	6	6"

See sheet 5 for foundation information.

Provide a 3'-10" lap for # 6 bar circles or a 12" lap if bar circle lap is welded.

Vertical reinforcement bars must be bundled side by side, 3 bars per bundle, all in the same plane. Provide a 10'-9" lap, stagger the ends of the lap by the amount of the lap length.

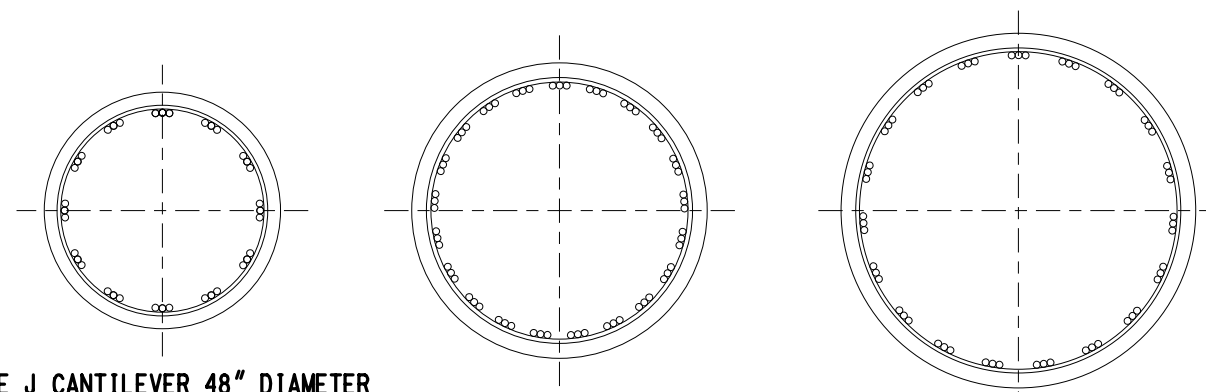

TYPE J CANTILEVER 48" DIAMETER

TYPE J CANTILEVER 60" DIAMETER

TYPE J CANTILEVER 72" DIAMETER

**SECTION A-A
(SHEET 1)**

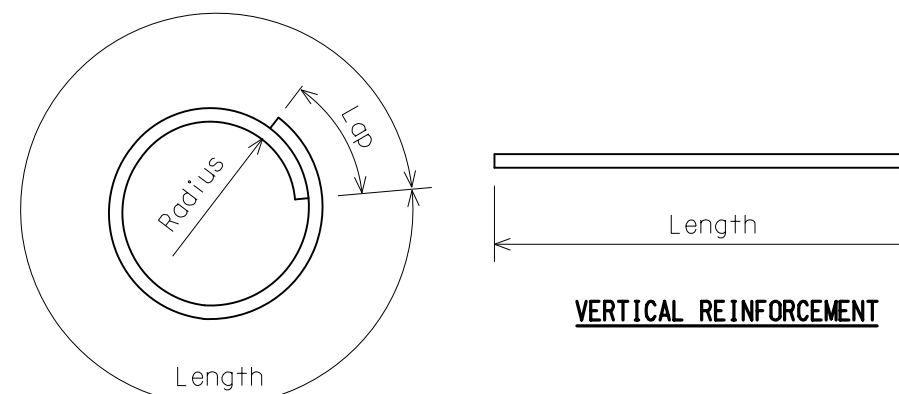

CONFINEMENT REINFORCEMENT

REINFORCEMENT DETAILS

NOT TO SCALE

Cantilever Foundation Chart						
Cantilever Type	Soil Type	Soil Condition		Diameter (in)	Depth "D" (ft)	Concrete (cyd)
		Suc	N			
J	Low Sand	-	$5 < N < 10$	48*	37	17.3
	Med Sand	-	$10 \leq N < 20$		33	15.4
	High Sand	-	$N \geq 20$		31	14.5
	Low Clay	$400 < \text{Suc} < 1000$	-		52	24.3
	Med Clay	$1000 \leq \text{Suc} < 2000$	-		31	14.5
	High Clay	$\text{Suc} \geq 2000$	-		27	12.6
	Low Sand	-	$5 < N < 10$	60**	45	32.8
	Med Sand	-	$10 \leq N < 20$		38	27.7
	High Sand	-	$N \geq 20$		38	27.7
	Low Clay	$400 < \text{Suc} < 1000$	-	72**	49	51.4
	Med Clay	$1000 \leq \text{Suc} < 2000$	-		35	36.7
	High Clay	$\text{Suc} \geq 2000$	-		31	32.5

* Use of 48"Ø drilled shaft foundation is for arm lengths with sign dimensions as shown in the graph below.

** 60" and 72" diameter drilled shaft foundation provided for information only.

A site specific foundation design is required if the maximum sign area for the specified arm length exceeds that shown in the graph below.

Suc = ultimate shear in cohesive soil (lbs/sq ft)

N = number of blows / foot of penetration (ASTM Testing Procedure D1586)

NOTE:

If soils with spt n-values greater than 50 bpf dominate the lower 1/2, or more, of a drilled shaft, or if rock sockets for the drilled shafts are required, then a detailed site specific design for the drilled shaft foundation is required.

MAXIMUM SIGN DIMENSIONS - TYPE J CANTILEVER FOR 48" DIA. DRILLED SHAFT FOUNDATION

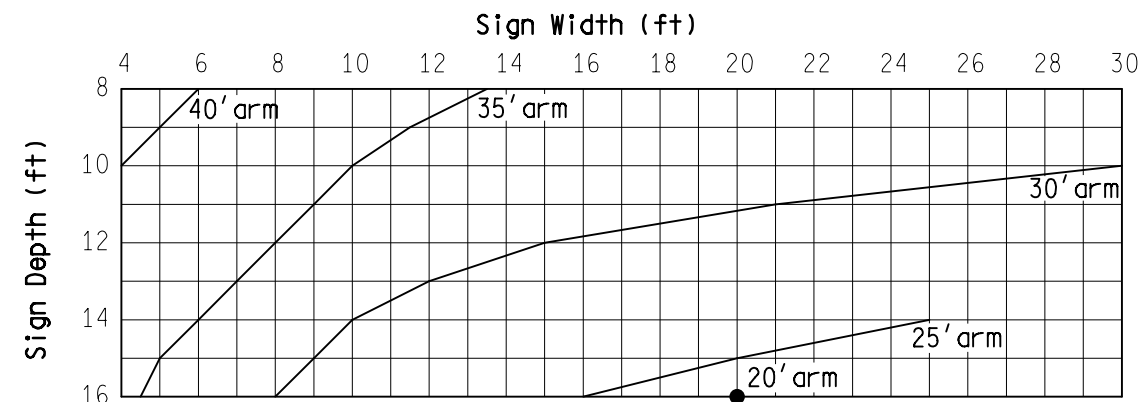

NOT TO SCALE

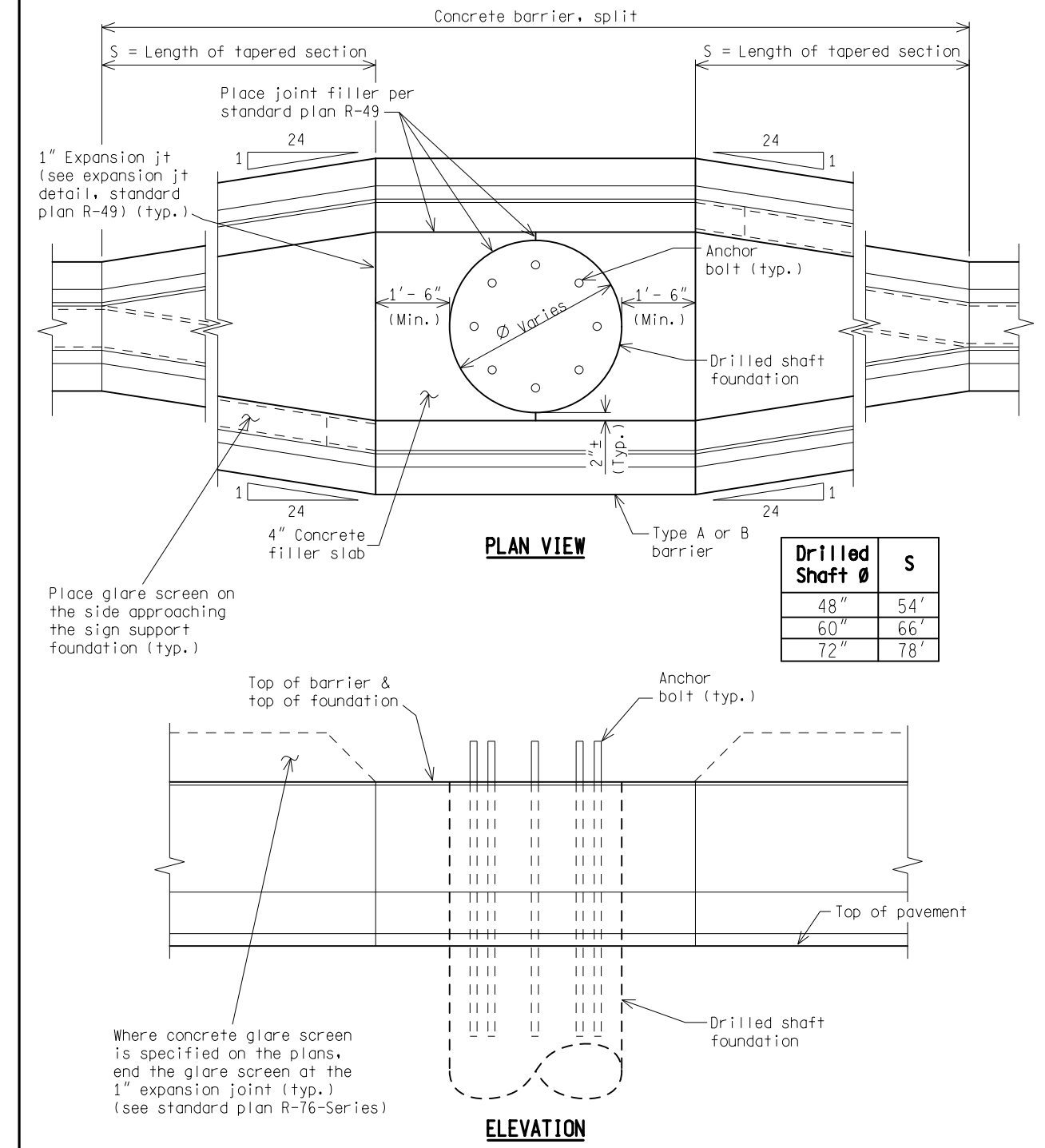

Drilled Shaft Ø	S
48"	54'
60"	66'
72"	78'

MEDIAN BARRIER FOUNDATION DETAILS

NOTE:

When the foundation is located within the median barrier, use standard plan R-49-Series. Increase the foundation depth by the height of the barrier (not including the height of the glare screen, if present) and locate the top of foundation at the top of barrier. Provide a parallel barrier section along the drilled shaft foundation.

Specific details vary depending on the use of Type A or Type B barrier. For barrier details not shown see standard plan R-49.

NOT TO SCALE