

BASE MOUNTED TRAFFIC SIGNAL CONTROLLER CABINET

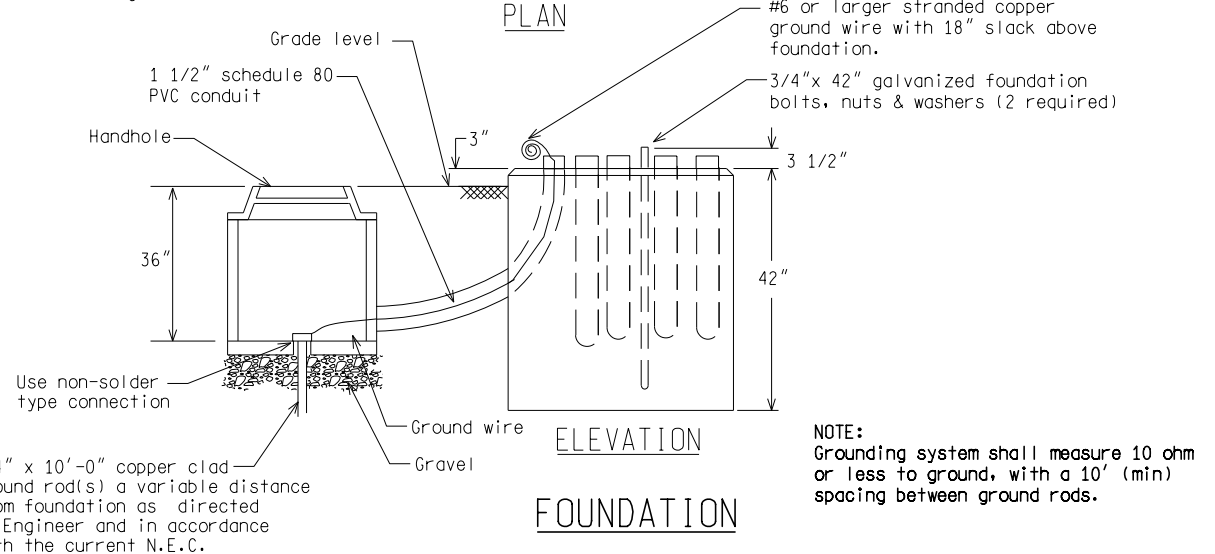

NOT TO SCALE		File:PW:RD/TR/Signals/WC SD/Final	Rev. 10/21/14
<p>MICHIGAN DEPARTMENT OF TRANSPORTATION</p>	ENGINEER OF DELIVERY	<p>MICHIGAN DEPARTMENT OF TRANSPORTATION BUREAU OF HIGHWAYS DELIVERY STANDARD PLAN FOR BASE MOUNTED T.S. CONTROLLER CABINET/FOUNDATIONS</p>	
	ENGINEER OF DEVELOPMENT		
DRAWN BY: CHECKED BY:	(SPECIAL DETAIL) FHWA APPROVAL DATE	PLAN DATE	SHEET 1 of 4

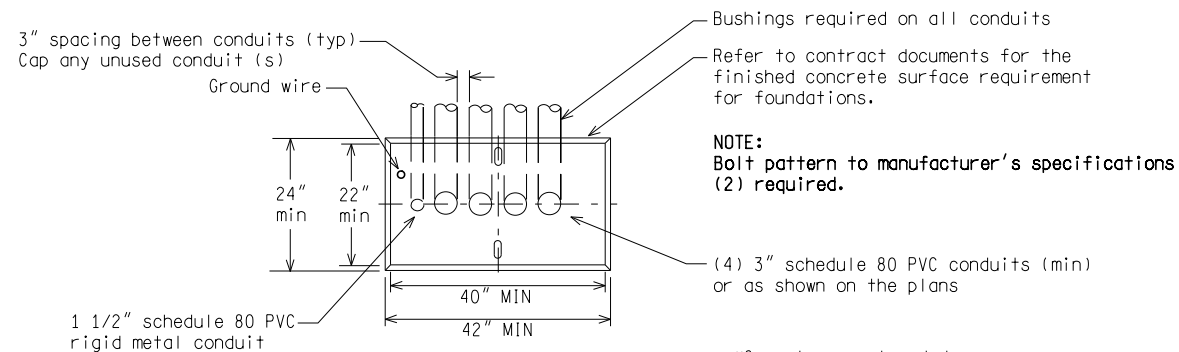
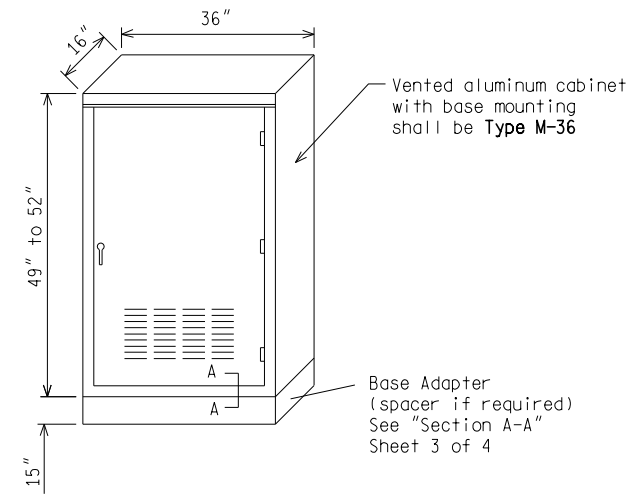

BASE MOUNTED TRAFFIC SIGNAL CONTROLLER CABINET

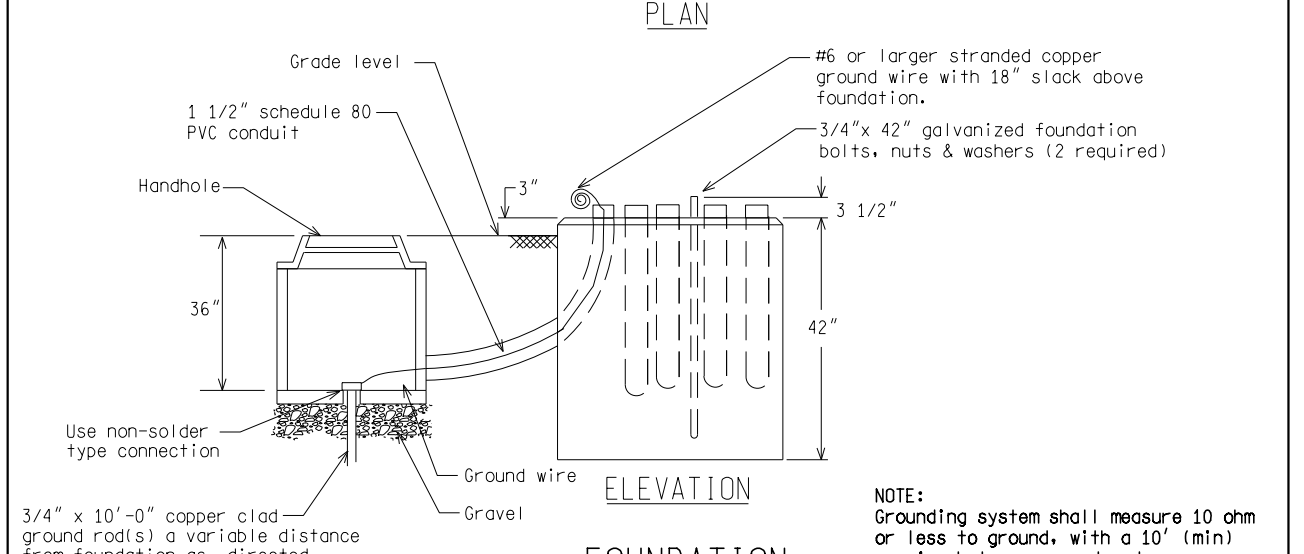
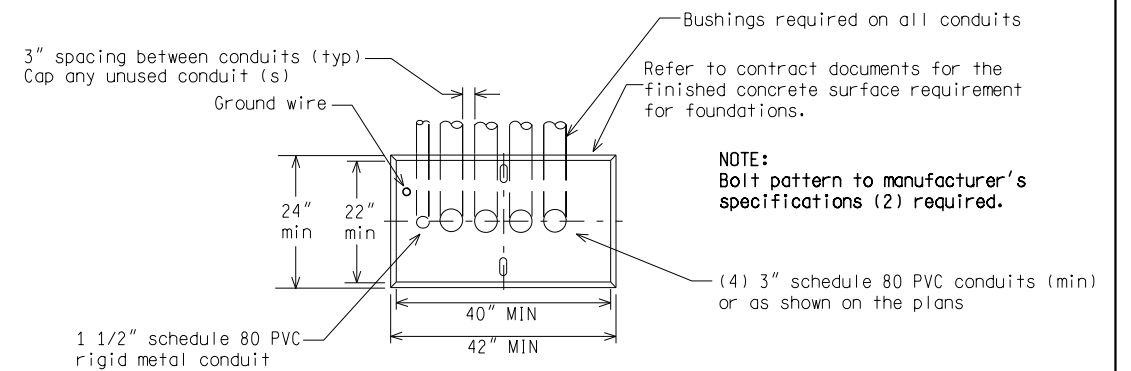

NOT TO SCALE		File:PW:RD/TR/Signals/WC SD/Final	Rev. 10/21/14
<p>MICHIGAN DEPARTMENT OF TRANSPORTATION</p>	ENGINEER OF DELIVERY	<p>MICHIGAN DEPARTMENT OF TRANSPORTATION BUREAU OF HIGHWAYS DELIVERY STANDARD PLAN (SPECIAL DETAIL) FHWA APPROVAL DATE</p>	
	ENGINEER OF DEVELOPMENT		
DRAWN BY: CHECKED BY:	(SPECIAL DETAIL) FHWA APPROVAL DATE	PLAN DATE	SHEET 2 of 4

AS-LET PLAN REVISIONS							
NO.	DATE	AUTH	DESCRIPTION	NO.	DATE	AUTH	DESCRIPTION



DATE:	CS:	DRAWING	SHEET
DESIGN UNIT:	JN:		
FILE:	TSC:		

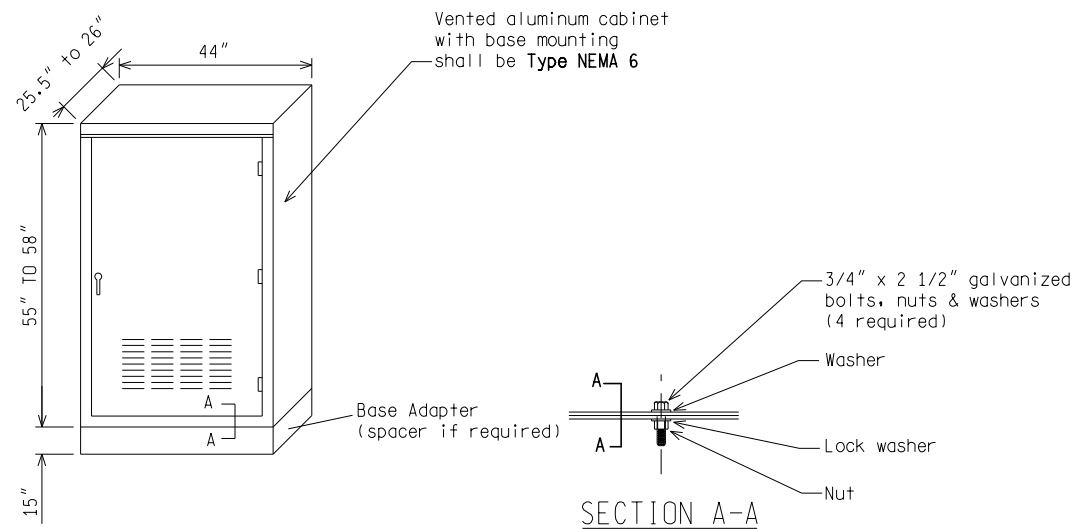

BASE MOUNTED TRAFFIC SIGNAL CONTROLLER CABINET

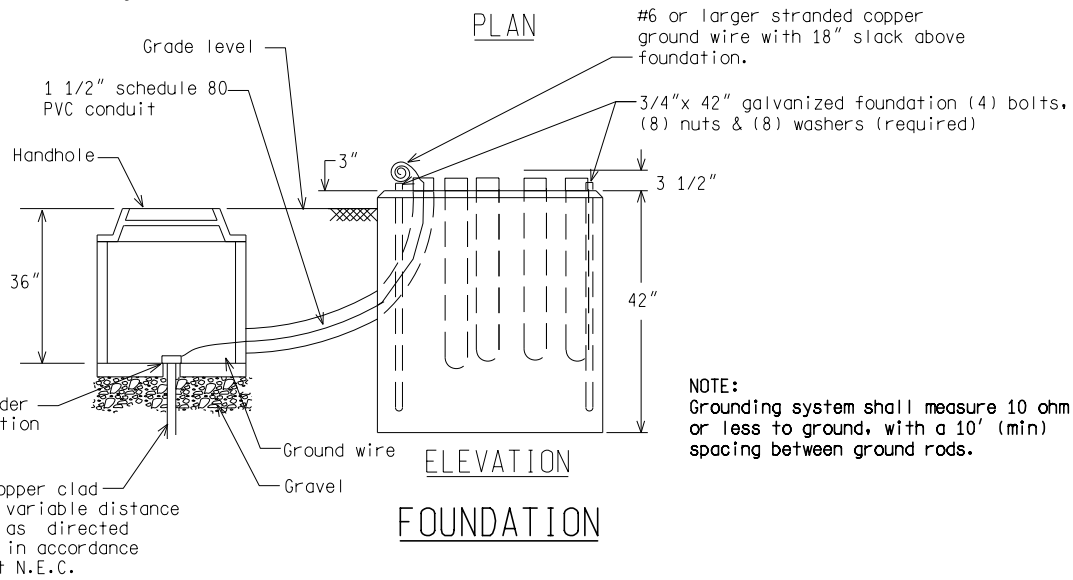
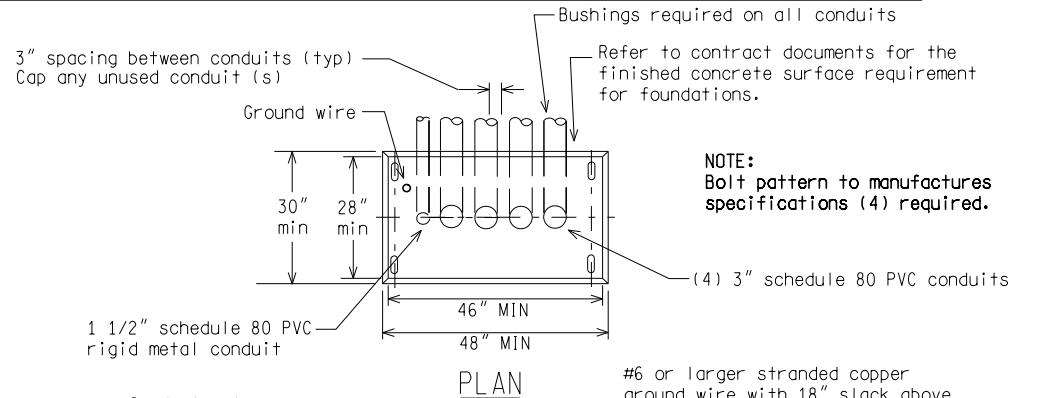

NOT TO SCALE

MICHIGAN DEPARTMENT OF TRANSPORTATION BUREAU OF HIGHWAYS DELIVERY STANDARD PLAN	(SPECIAL DETAIL) FHWA APPROVAL DATE	Rev. 10/21/14	PLAN DATE	WC-045-A	SHEET 3 of 4
--	--	---------------	-----------	----------	-----------------

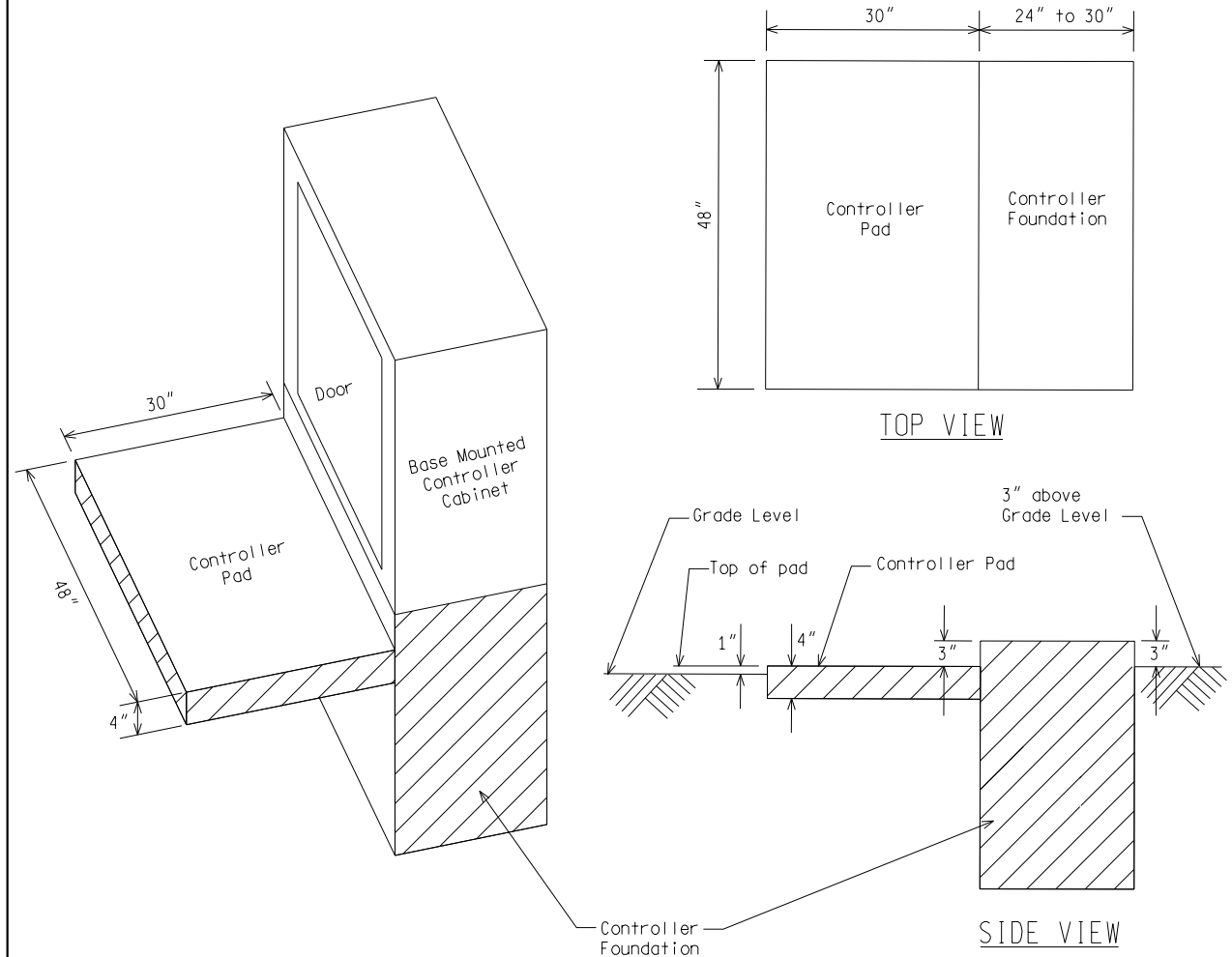

BASE MOUNTED CONTROLLER PAD

NOTE:
Payment for controller pad to be included in controller foundation pay item.
Controller cabinet door to open toward pad.

NOT TO SCALE

MICHIGAN DEPARTMENT OF TRANSPORTATION BUREAU OF HIGHWAYS DELIVERY STANDARD PLAN	(SPECIAL DETAIL) FHWA APPROVAL DATE	Rev. 10/21/14	PLAN DATE	WC-045-A	SHEET 4 of 4
--	--	---------------	-----------	----------	-----------------

AS-LET PLAN REVISIONS							
NO.	DATE	AUTH	DESCRIPTION	NO.	DATE	AUTH	DESCRIPTION



DATE:	CS:	DRAWING	SHEET
DESIGN UNIT:	JN:		
FILE:	TSC:		