

**SHARED LANE WITH ON-STREET PARALLEL PARKING**

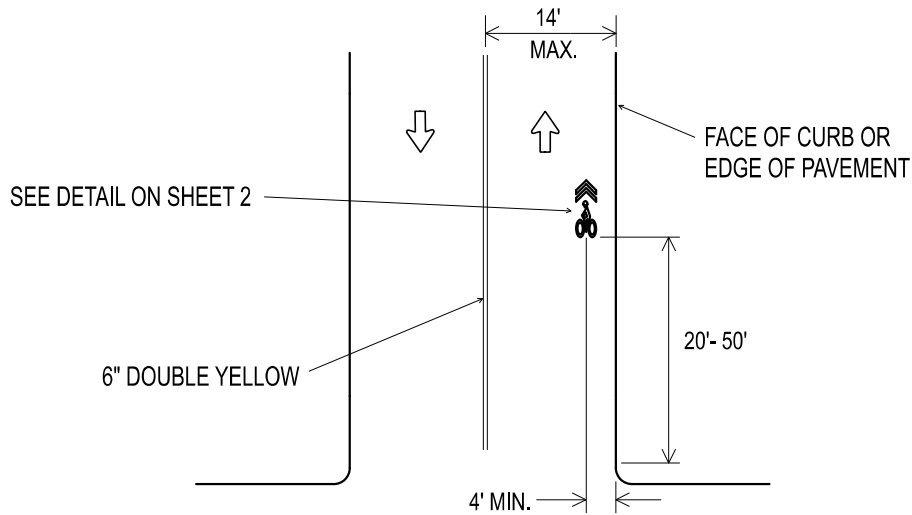

**SHARED LANE WITH NO ON-STREET PARKING**

**NOTES:**

1. REFER TO THE AASHTO GUIDE FOR THE DEVELOPMENT OF BICYCLE FACILITIES FOR APPROPRIATE USE OF MARKING.
2. WHEN USED, SPACE SHARED LANE MARKING AT INTERVALS NO GREATER THAN 250 FT.
3. REFER TO PAVE-955 FOR ON-STREET PARKING ZONE MARKING DETAILS.

NOT TO SCALE

APPROVED BY: \_\_\_\_\_  
DIRECTOR, BUREAU OF FIELD SERVICES

APPROVED BY: \_\_\_\_\_  
DIRECTOR, BUREAU OF DEVELOPMENT



DEPARTMENT DIRECTOR  
BRADLEY C. WIEFERICH, PE

STANDARD PLAN FOR  
SHARED LANE  
(SHARROW) MARKING

11/22/2023  
FHWA APPROVAL

09/13/2023  
PLAN DATE

PAVE-961-D

SHEET  
1 OF 2

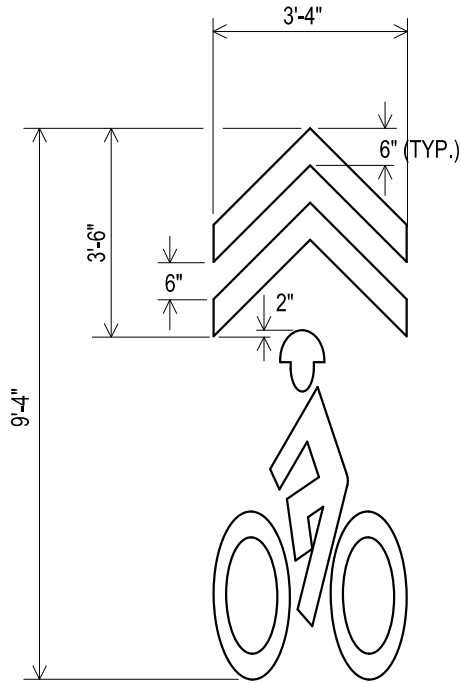

**DETAIL OF SHARED LANE (SHARROW) MARKING**

NOT TO SCALE



DEPARTMENT DIRECTOR  
BRADLEY C. WIEFERICH, PE

STANDARD PLAN FOR  
SHARED LANE  
(SHARROW) MARKING

11/22/2023  
FHWA APPROVAL

09/13/2023  
PLAN DATE

PAVE-961-D

SHEET  
2 OF 2