

2 to 4 turns of wire per specification
(wires not twisted in loop slot)
see detail "D" sheet 2 of 4
for wire restraints

Overlap cuts so that slot has full
depth see detail "A" sheet 2 of 4

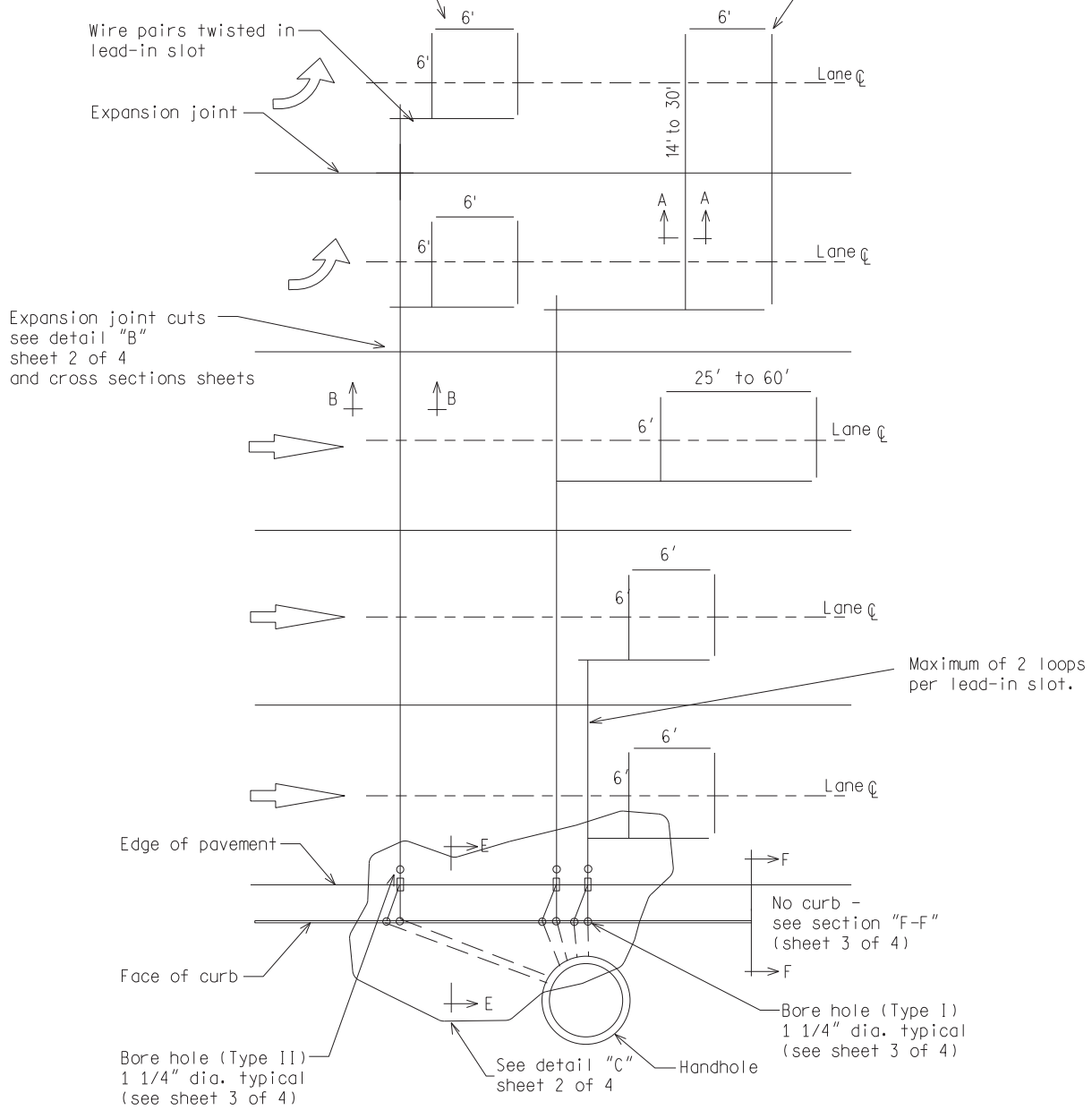

NOTES:
Lead-in slot may be on either near or far side of
loop approach as directed by the Engineer.
Two loops maximum allowed per saw cut from
loop to curb.
3 turns required for loops equal to
or greater than 6'x10'
4 turns required for loops less
than 6'x10'
Refer to contract documents for high pressure
washing of saw cuts and removal of debris

NOT TO SCALE

File: RefDoc/TR/Signals/Web/Sp Det/Fin/SIG410A.dgn Rev: 02/16/17



PREPARED BY
TRAFFIC AND SAFETY

DRAWN BY:

CHECKED BY:

ENGINEER OF DELIVERY

ENGINEER OF DEVELOPMENT

(SPECIAL DETAIL)

FHWA APPROVAL DATE

MICHIGAN DEPARTMENT OF TRANSPORTATION
BUREAU OF HIGHWAYS DELIVERY STANDARD PLAN FOR

TRAFFIC LOOPS

PLAN DATE

SIG-410-A

SHEET
1 of 4

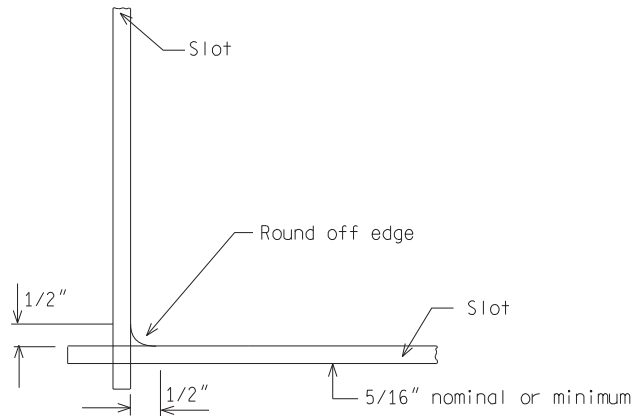

DETAIL A
CORNER CUTS

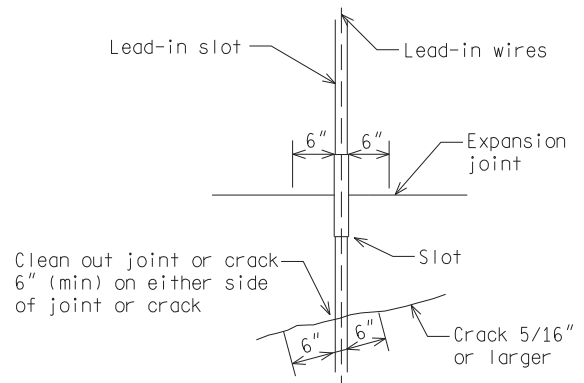

DETAIL B
EXPANSION JOINT CUTS

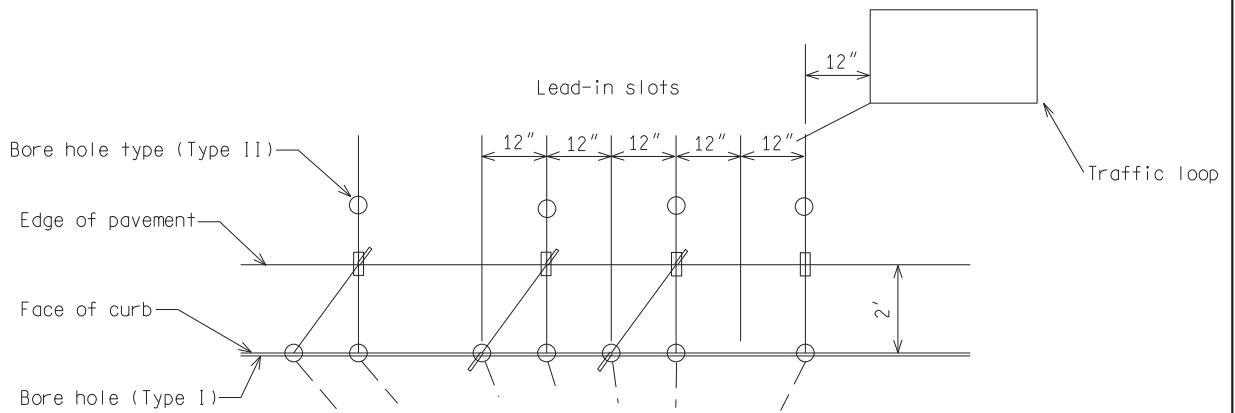

DETAIL C
TERMINATION OF LEAD-IN SLOTS

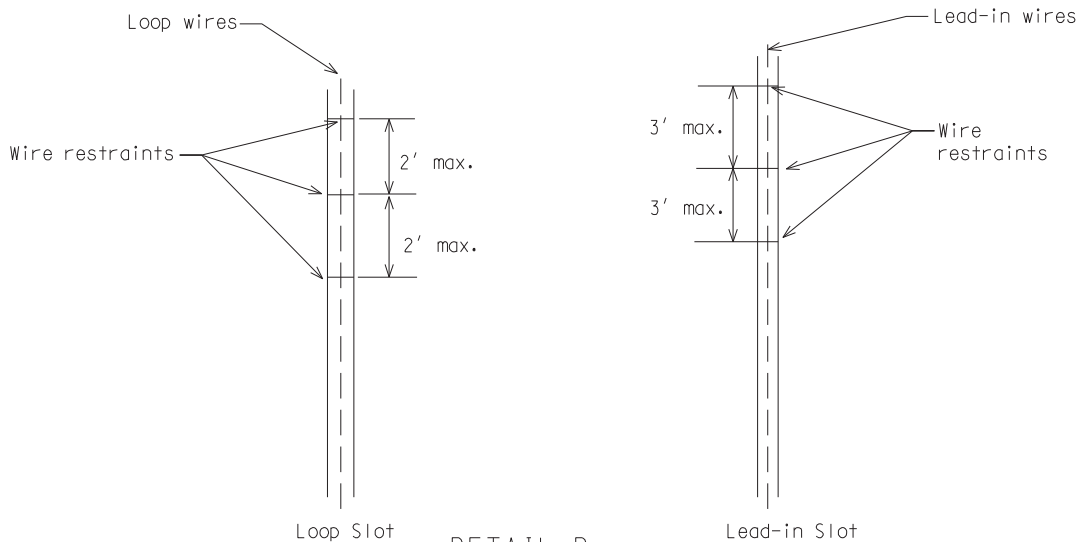

DETAIL D
WIRE RESTRAINTS

NOT TO SCALE

MICHIGAN DEPARTMENT OF TRANSPORTATION
BUREAU OF HIGHWAYS DELIVERY STANDARD PLAN

(SPECIAL DETAIL)
FHWA APPROVAL DATE

File: RefDoc/TR/Signals/Web/Sp Det/Fin/SIG410A.dgn

Rev. 02/16/17

PLAN DATE

SIG-410-A

SHEET
2 of 4

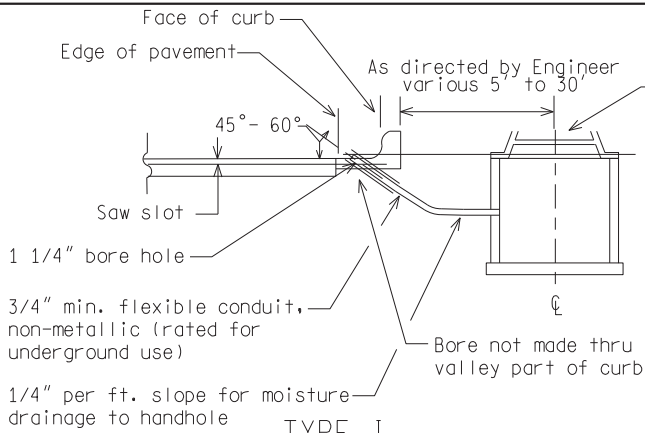

TYPE I
SECTION "E-E"
UNDER CURB INSTALLATION

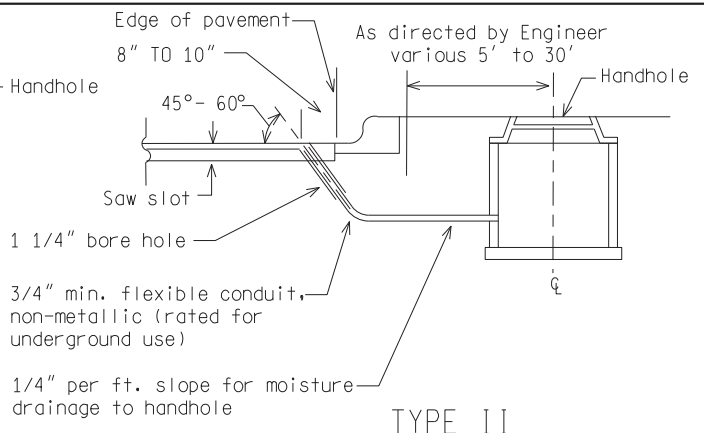

TYPE II
SECTION "E-E"
UNDER CURB INSTALLATION

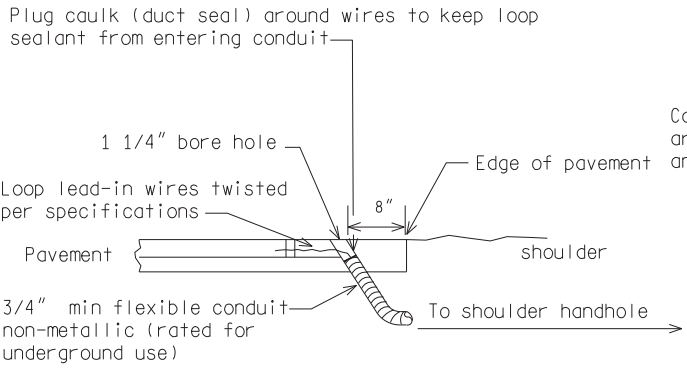

BORE HOLE & LOOP WIRING
SECTION F-F
UNDER PAVEMENT INSTALLATION

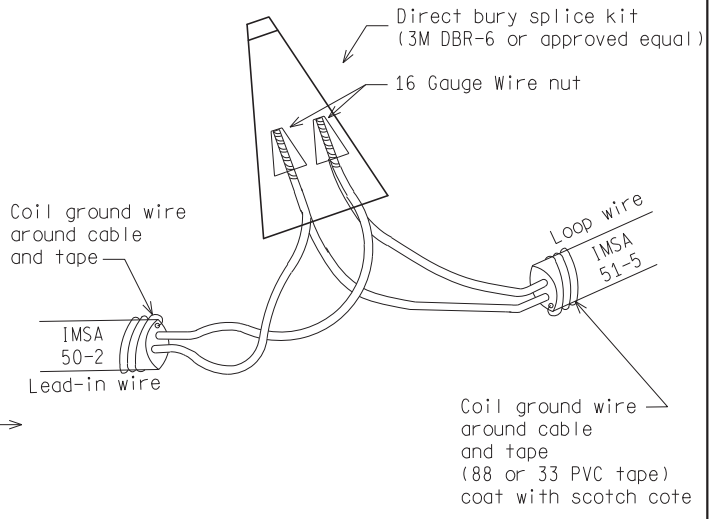

HANDHOLE & PULL-BOX SPLICES
(WATERPROOF)

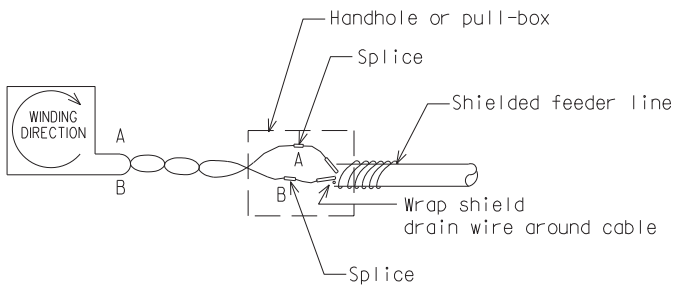

SINGLE LOOP CONNECTION

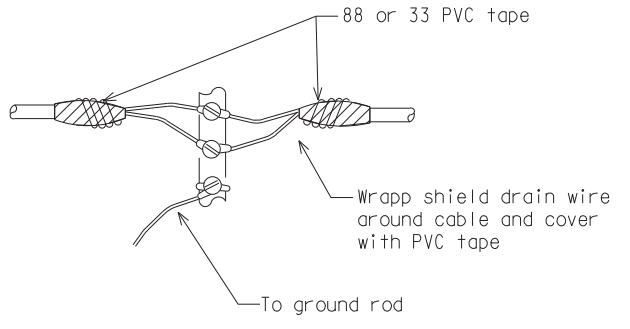

CONTROLLER CABINET CONNECTION

NOT TO SCALE

MICHIGAN DEPARTMENT OF TRANSPORTATION
BUREAU OF HIGHWAYS DELIVERY STANDARD PLAN

(SPECIAL DETAIL)
FHWA APPROVAL DATE

File: RefDoc/TR/Signals/Web/Sp Det/Fin/SIG410A.dgn

Rev. 02/16/17

PLAN DATE

SIG-410-A

SHEET
3 of 4

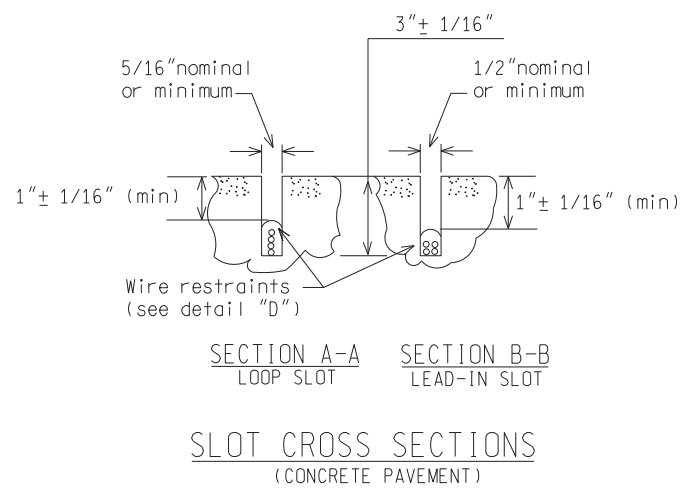
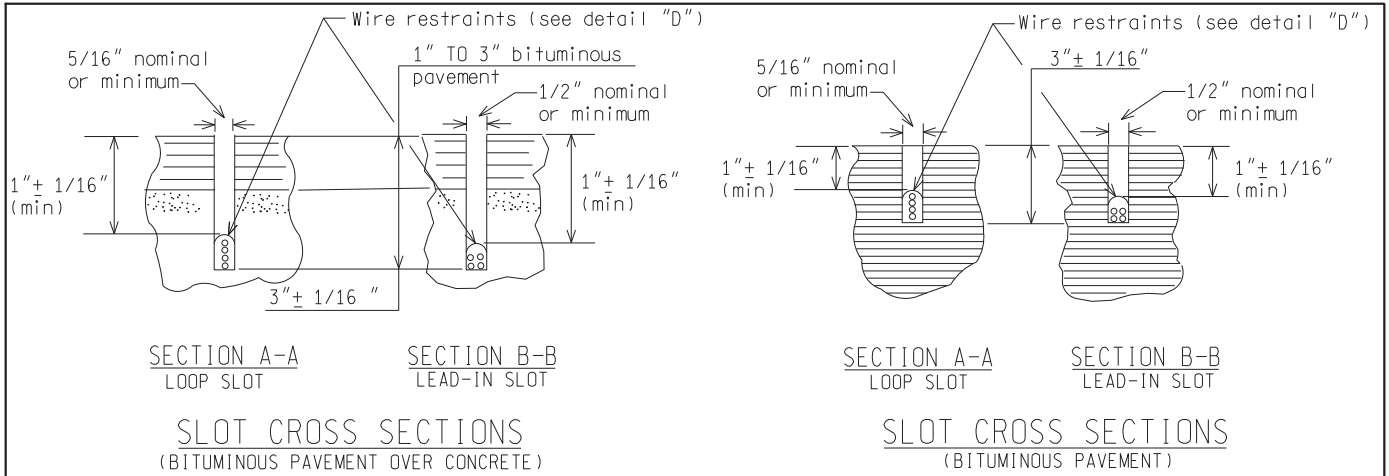

NOT TO SCALE

MICHIGAN DEPARTMENT OF TRANSPORTATION BUREAU OF HIGHWAYS DELIVERY STANDARD PLAN	(SPECIAL DETAIL) FHWA APPROVAL DATE		SIG-410-A	SHEET 4 of 4
File: RefDoc/TR/Signals/Web/Sp Det/F in/SIG410A.dgn Rev. 02/16/17		PLAN DATE		