

MACHINE FINISHING OF BRIDGE B01 of 11016
I 94 over the St. Joseph River

G. R. Cudney

Research Laboratory Division
Office of Testing and Research
Research Project 60 F-57
Report No. 373

LAST COPY
DO NOT REMOVE FROM LIBRARY

Michigan State Highway Department
John C. Mackie, Commissioner
Lansing, March 1962

MACHINE FINISHING OF BRIDGE B01 of 11016 I 94 over the St. Joseph River

This report describes an evaluation of stringer deflections of Bridge B01 of 11016 (formerly B1 of 11-2-6) during deck finishing operations, as caused by use of an 18,000-lb bridge finishing machine, and an appraisal of the roughness of the completed deck surface. This investigation was carried out in the Fall of 1960, and a progress report was presented at the 1961 Annual Highway Engineers Conference.

Bridge B01 of 11016 consists of a pair of bridges carrying the eastbound and westbound roadways of I 94 over the St. Joseph river southeast of Benton Harbor. Each bridge is on an 80° skew and is 644 ft long, consisting of a combination of eight overhanging and suspended spans. Each span contains eight 36-in., 150 lb per ft, wide-flange stringers, and a composite deck with a clear roadway of 30 ft. Because the design provided for addition of future lanes, the two fascia stringers of all spans except Span 1 had different stiffnesses. The location and size of the cover plates, a typical cross-section, and a longitudinal schematic are shown in Figs. 1, 2, and 3.

Construction Operations

Since machine finishing of bridge decks involves continuous pouring and finishing, control of retardation of the initial set of concrete is important to provide for possible stoppage or delay in operations, and, as was the case for these two bridges, where a pouring sequence includes a section of negative bending moment. The retarding admixture used on this project was "Plastiment," and mix designs and concrete control were under supervision of the Testing Laboratory Division at Ann Arbor. The other phases of the study were conducted by the East Lansing Research Laboratory Division.

The finishing machine used was manufactured by the construction machinery division of the Chain Belt Co. (Fig. 4). It weighs 18,000 lb and is supported at each side by three wheels spaced at 3 ft 7 in. and 1 ft 10 in. This machine has a variable width frame and a single oscillating screed 16 in. wide with a maximum lateral screed displacement of 5 in.

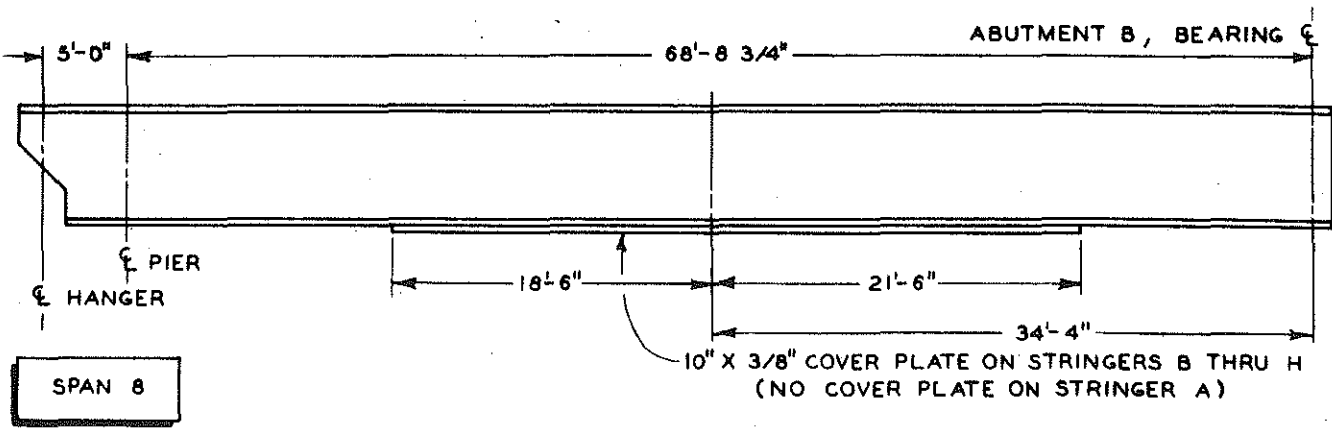
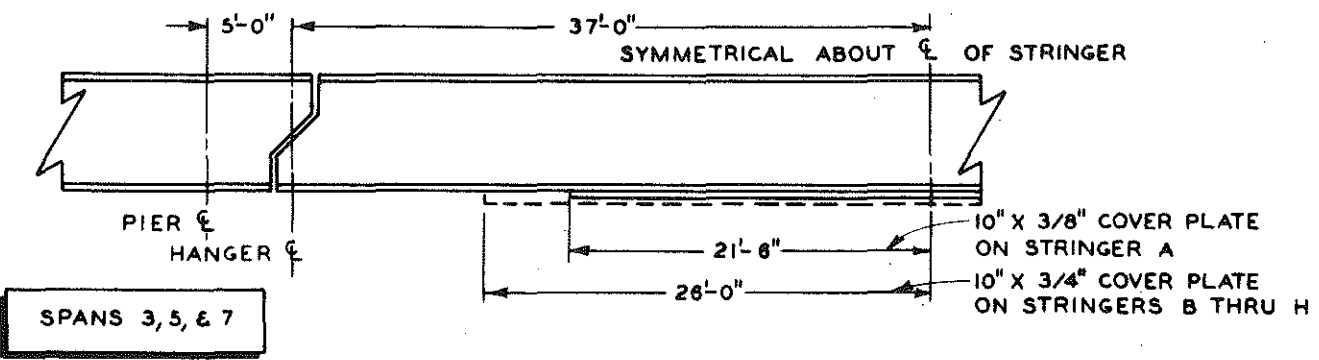
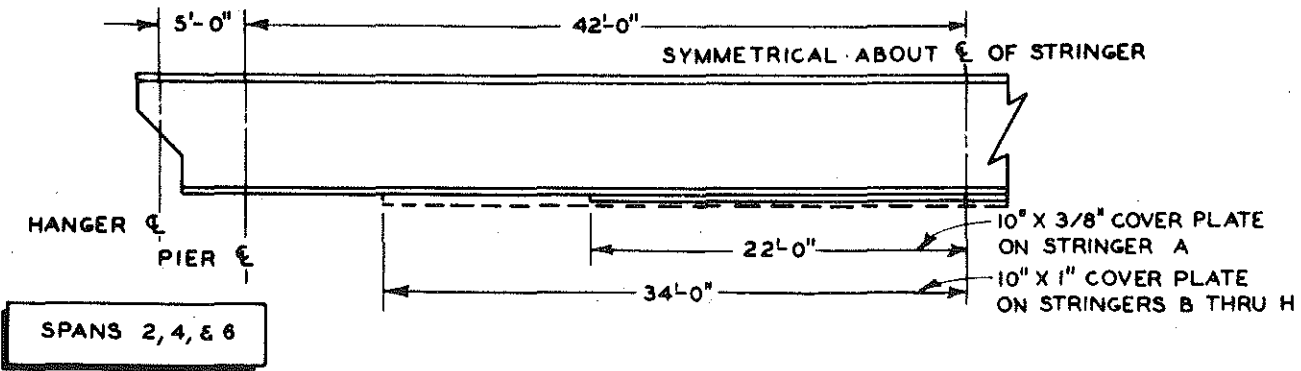
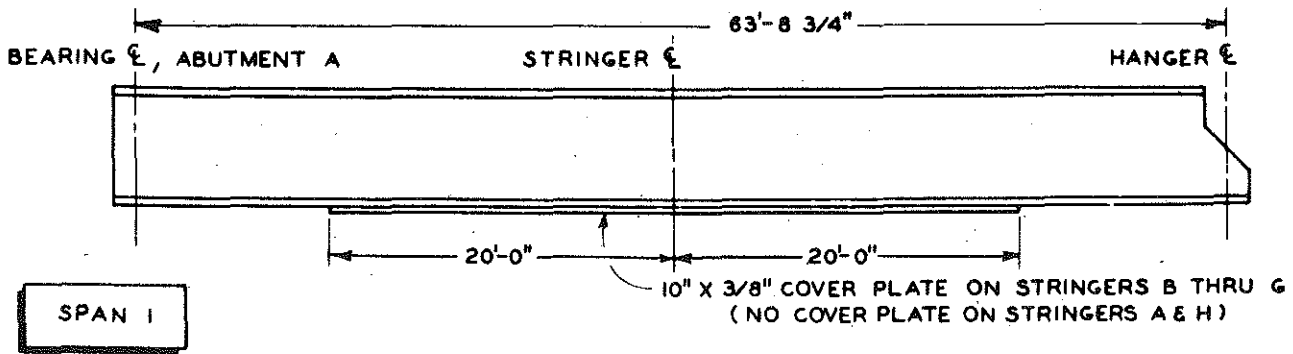

Figure 1. Cover plate locations on 36 W^F 150 stringers.

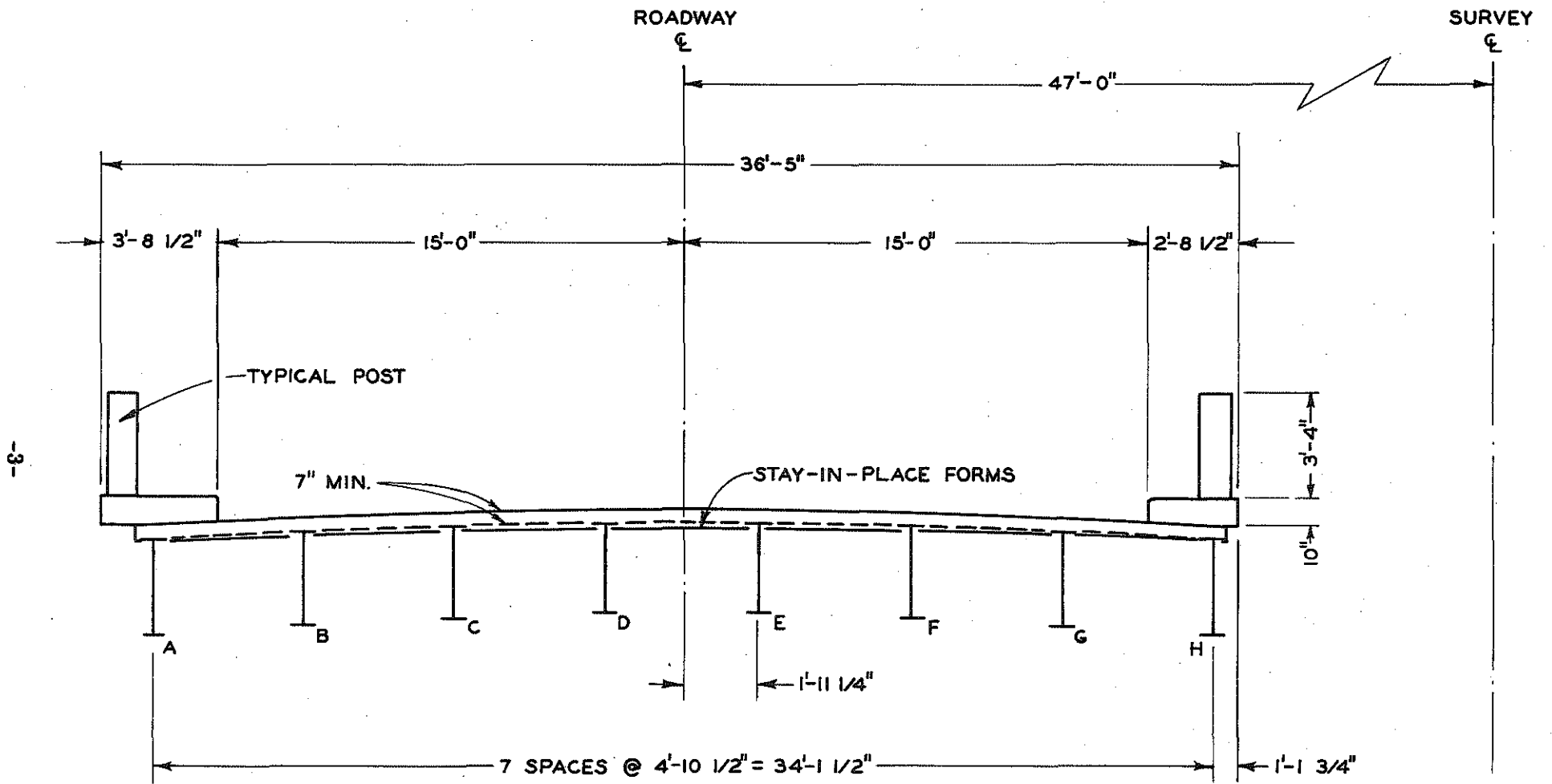

Figure 2. Typical cross-section.

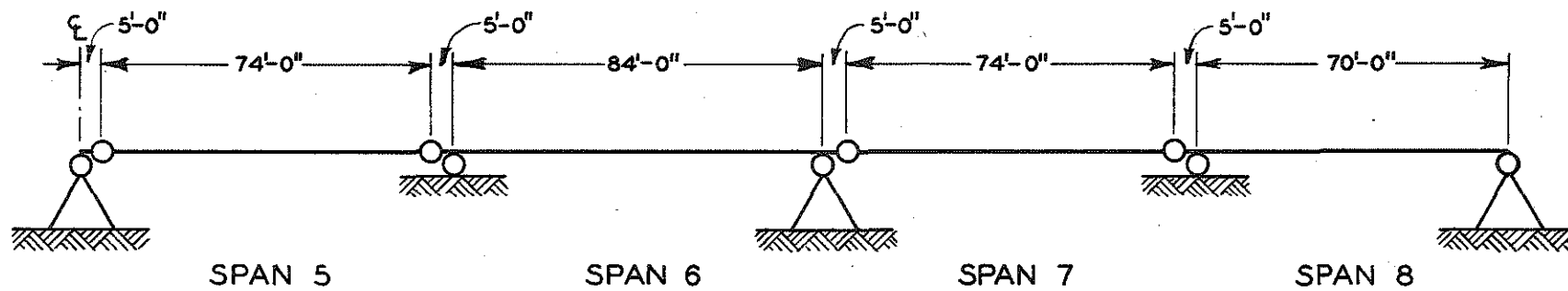
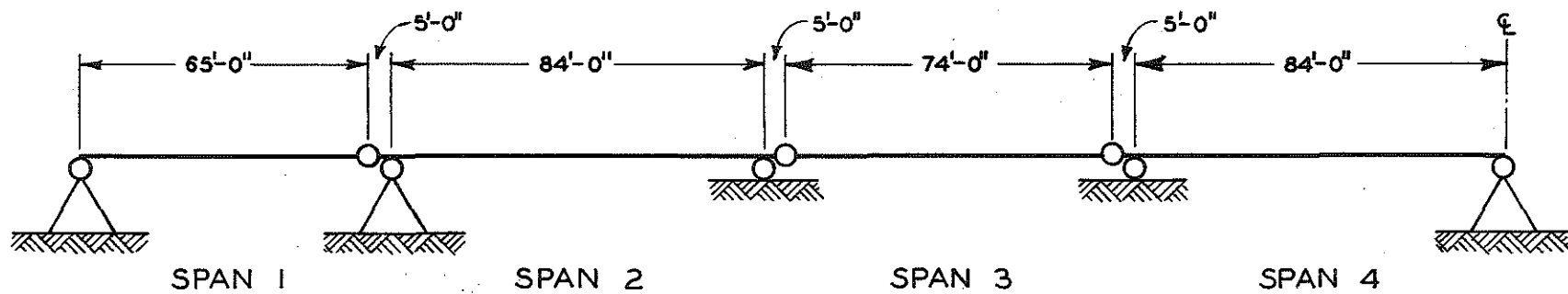
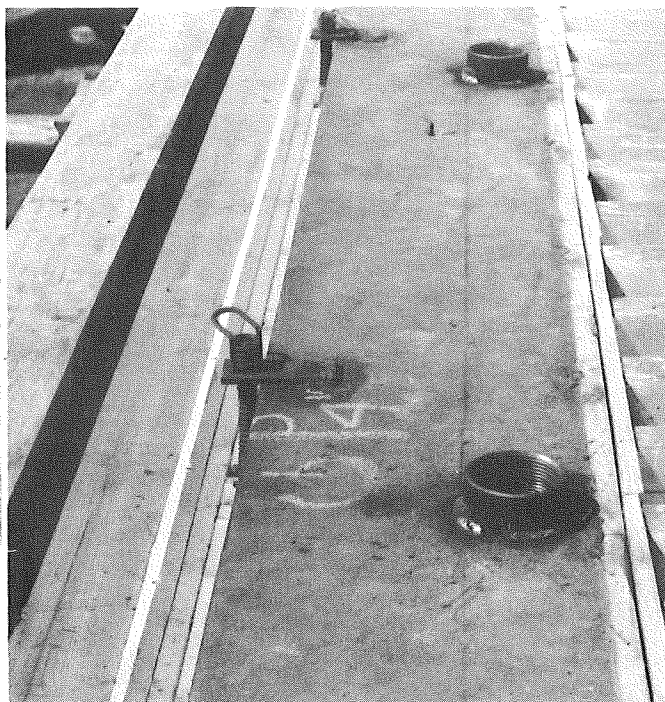

Figure 3. Schematic diagram.



Bridge finishing machine (above).



Pipe sleeves welded to fascia stringer (right).

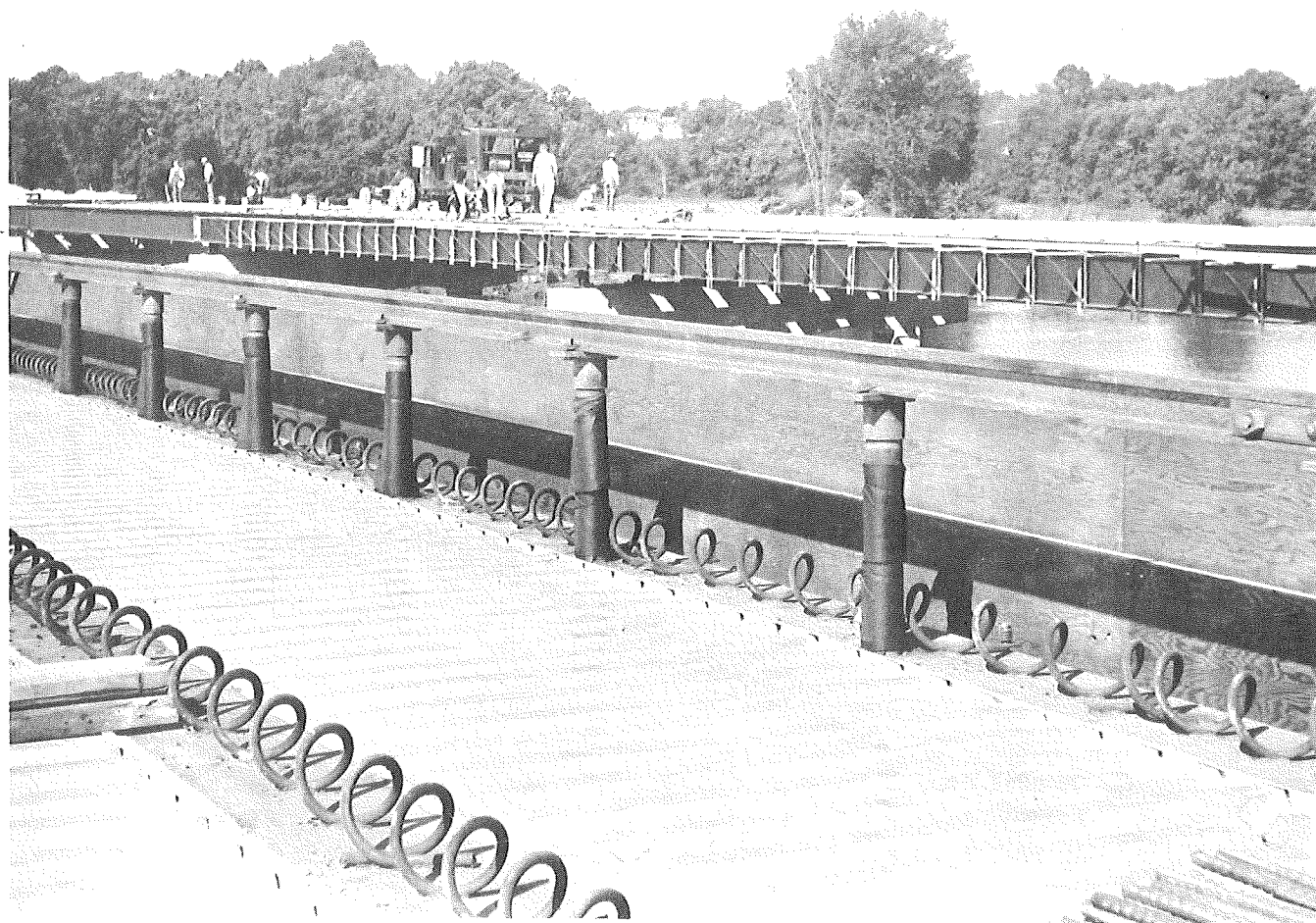

Threaded pipe and machine rail support.

Figure 4. Finishing machine and support rail.

The rails on which the machine rode were supported every 4.5 ft on pipes threaded into sleeves welded to the top flanges of the two fascia stringers. These pipe posts were covered with bituminous wrapping paper to facilitate their removal and re-use after a pouring sequence was finished. The sleeves and completed rail support are also shown in Fig. 4. Stay-in-place corrugated steel forms were also used in construction, welded to the stringers and remaining as permanent parts of the structure. These forms and the deck reinforcement are shown prior to pouring in Fig. 5.

Concrete was transported from the end of the bridge to the finisher by means of a specially designed, self-powered machine which used the same rails as the finisher (Fig. 6). This machine was equipped with a hydraulically operated 2.5-yd capacity dump body which could be maneuvered back and forth along its length.

The order of pouring for the eastbound bridge was as follows: first day, Span 5; second day, Spans 6 and 7; third day, Span 8; seventh day, Span 1; eighth day, Spans 2 and 3; and ninth day, Span 4. All slabs were poured before any sidewalk, median, or railing were placed. By following this pouring sequence, only 12 start-up periods were required--6 per bridge as opposed to 32 if normal hand-finishing procedures had been employed.

The work crew required for the finishing operation consisted of a machine operator, two hand-finishers, two concrete muckers, and a vibrator man. The entire width of roadway was finished in one operation, utilizing the machine for the center 30 ft of the deck, and hand-finishing for the slab portions under the sidewalks. Placing and finishing operations are shown in Figs. 7, 8, and 9. This type of construction, of course, eliminated the longitudinal centerline bulkhead and construction joint which would ordinarily have been required. The average rate of pour was about 30 cu yd per hr, corresponding to approximately 30 lin ft per hr. The longest continuous pouring sequence was 168 ft, and the shortest was 64 ft.

Deflection Evaluation

Three spans were selected on the eastbound bridge for measurement of stringer deflections. Span 8 was instrumented to obtain the transverse load distribution of the finishing machine only, with deflections measured at the quarter, two-thirds, and three-quarters points of the two fascia stringers, and at the center and two-thirds points of the remaining interior stringers.

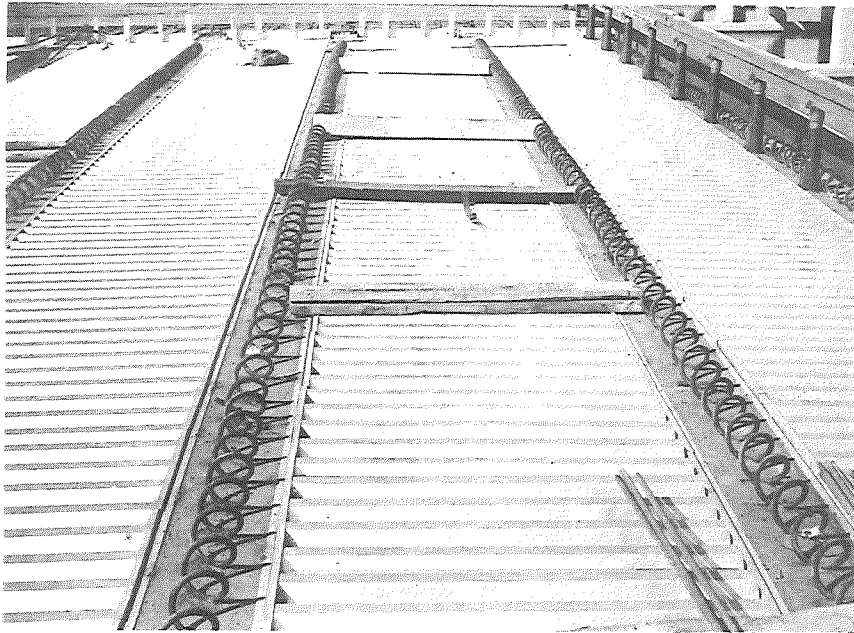

▲ Figure 5. Stay-in-place corrugated metal forms (top left) and deck reinforcement with spiral shear developers (top right).

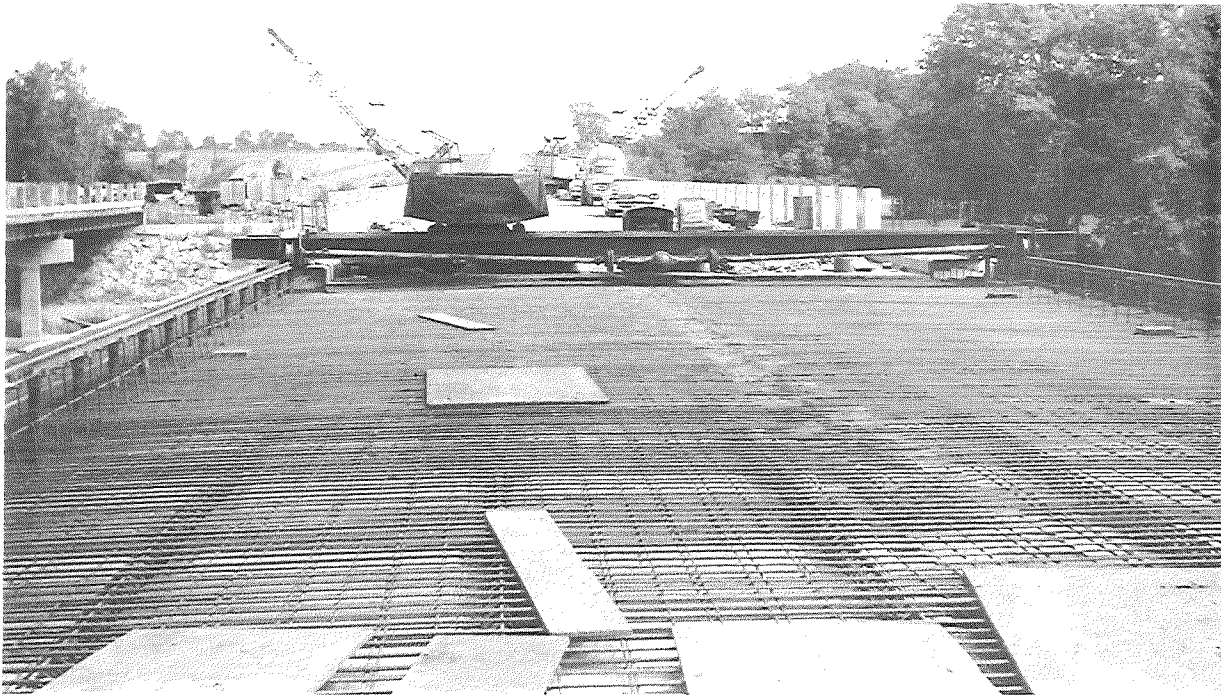

◀ Figure 6. Concrete transporting machine (2.5 yd capacity).

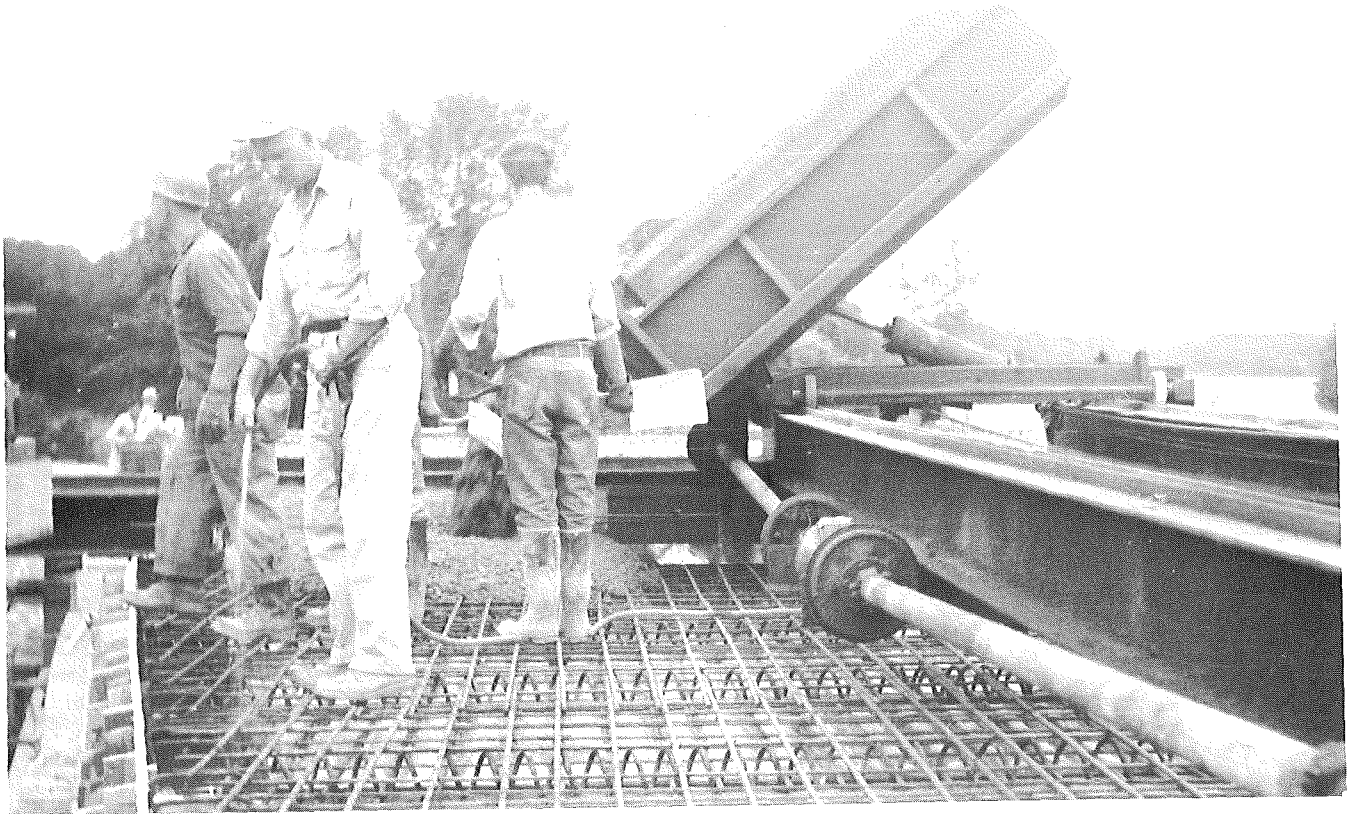

Figure 7. Placing concrete on Span 1.

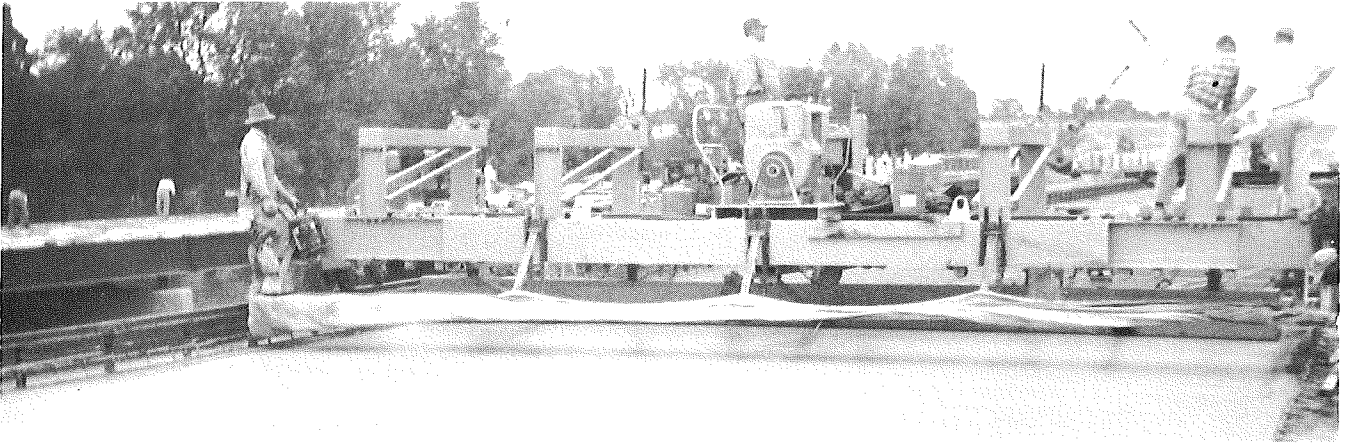

Figure 8. Finishing machine in operation on Span 1.

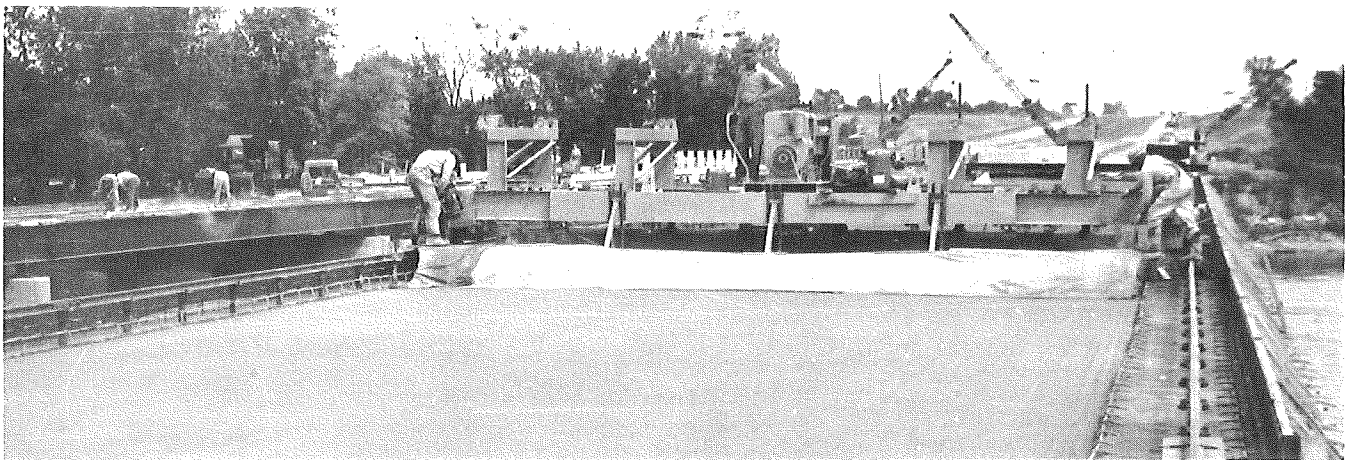

Figure 9. Applying burlap drag on Span 1.

Deflections were also obtained, during the placing and finishing operation, at the quarter, center, and three-quarters points of the fascia stringers and at the center of the interior stringers of Spans 1 and 2 due to the finishing machine and deck load. All these deflections were measured with 0.001-in. dial indicators. A 5-lb weight was attached to the lower stem of each dial, which in turn was fixed to a base firmly entrenched in the ground. A wire strand was attached to the top of the dial stem and affixed to the lower flange of the stringers. Initial zero adjustments were made by means of a turnbuckle fastened to the wire above the dial. A typical deflectometer set-up is shown in Fig. 10.

Since the finishing machine was supported directly on the two fascia stringers, the resulting transverse load distribution depended on the relative stiffness of the adjacent stringers and their connecting diaphragms.

The percent load distributions of the finishing machine on Span 8, at the center and two-thirds points, are plotted in Fig. 11. The diaphragm connections between stringers were at the one-third points of this span. The same graphs also show the analytical load distributions, for the different machine load positions, as determined by the bridge consultants. Average measured stringer load distribution with the machine at each of the four points on each fascia stringer was as follows: 53 percent to the fascia stringer, 29 percent to the next adjacent stringer, 12 percent to the next, and 6 percent to the center, where the design distributions as presumed by the bridge consultants were 32, 30, 21, and 17 percent, respectively. Average maximum fascia stringer deflection was found to be 0.26 in.

Two situations arise in which deflection distribution of the stringers, as a result of the imposed finishing machine loads, affect the final configuration of the deck. First, since the screed elevation during finishing at any point on the span is governed by the deflection of the fascia stringers, there is a tendency for progressive flattening of the crown and reduction of slab thickness from the fascia stringer toward the center interior stringer. The magnitude of this deviation will be equal to the relative machine load and slab load deflection of the fascia stringer, and any interior stringer, and will be greatest at the point on the span where relative fascia and center stringer deflection is maximum. The maximum measured deviation occurring in Span 2, with the machine at and the concrete deck slab finished to the center of the span, amounted to 0.15 in. In the process of finishing in a single continuous operation, as the concrete is placed on the span the effect of the greater fascia stringer

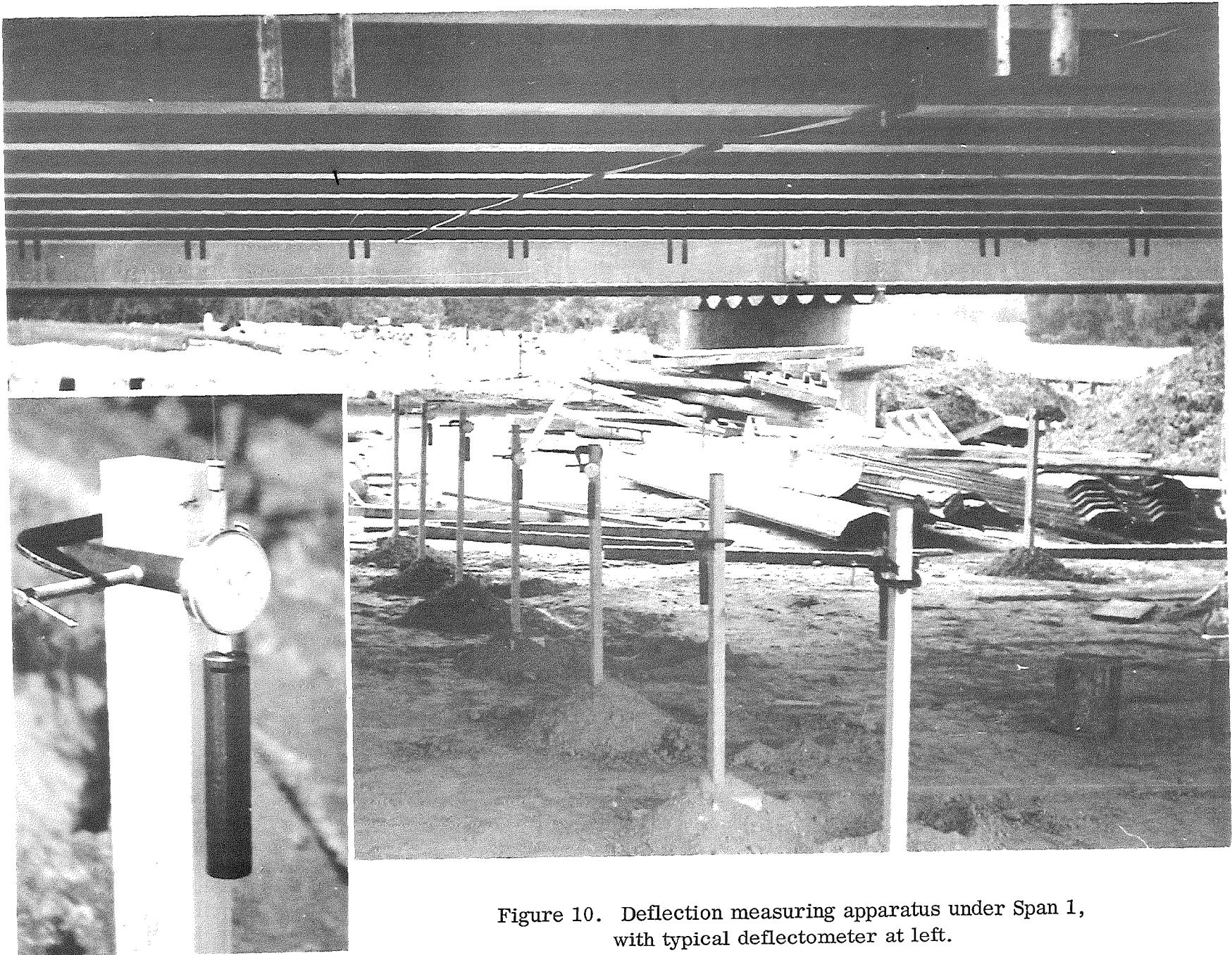

Figure 10. Deflection measuring apparatus under Span 1, with typical deflectometer at left.

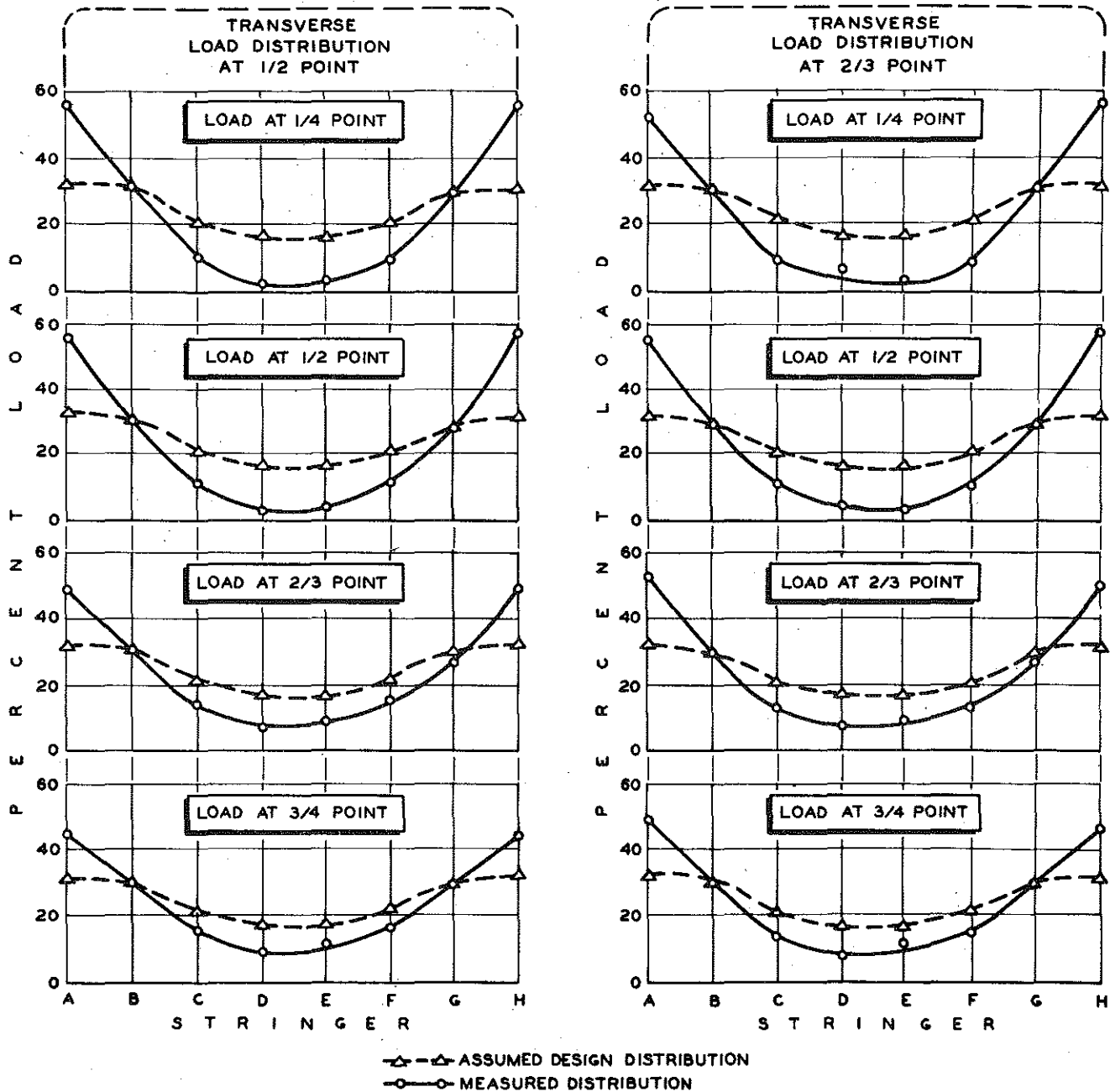

Figure 11. Assumed and measured transverse load distributions for four machine positions on Span 8.

deflections caused by the machine is offset by the greater percentage of the slab load carried by the interior stringers. With the deck pour completed and the finishing machine at the center of Span 2, for example, the maximum relative fascia and interior stringer deflection amounted to about 0.2 in.

In the second situation, the tendency is for the slab to become concave, or dish-shaped, between stringers at any point on the span as a result of the machine's moving away from that point and eventually off the span. The magnitude of this deviation will be equal to the relative machine load deflections of adjacent stringers. The maximum deviation occurs between the fascia stringer and the adjacent interior stringer, which for Span 2 amounted to 0.15 in. Deflection distribution for the stringers of Spans 1 and 2 for the various positions of the machine at various stages of completion of the deck, including the measured and computed slab dead load deflections is shown in Figs. 12 through 17. It should be pointed out that the asymmetry of these deflection curves is attributable to the different stiffnesses of the stringers, and to unsymmetrical loading because of the bridge skewness. Determination of the final screed elevations and subsequent rail elevations included the fascia stringer deflections caused by the sidewalk, railing, and wearing surface, on the assumption that 32 percent of this loading was distributed to the fascia stringer composite section. For Span 2, this computed deflection allowance, and subsequent slab thickness increase, was greater than the reduction in slab thickness at center span due to the finishing machine operation. Neither the 0.15 in. nor 0.20 in. deviations recorded on Span 2 were adjudged to have significant influence on the final configuration of the deck surface, and, generally, deflection distributions due to the machine finishing operation were deemed insignificant.

Roughness Evaluation

Surface roughness measurements were made with a 10-ft rolling straight edge profilometer. This instrument consists essentially of two fixed wheels 10 ft apart, and a movable center wheel (Fig. 18). As the instrument is rolled along a surface, the difference at a point midway between successive 10-ft planes established by the fixed end wheels is accumulated in 1/8-in. increments. Since this instrument does not have a standard calibration, surface roughness was compared for the machine-finished dual bridge and three conventionally finished bridges selected at random in the general vicinity. These three bridges included a three-span continuous T-beam (117 ft long), a four-span continuous T-beam (264 ft long), and a four-span simply supported rolled beam bridge (229 ft long).

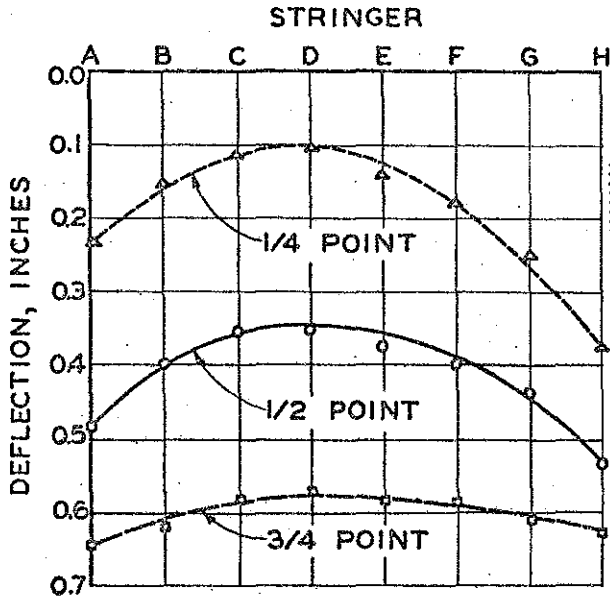

Figure 12. Transverse load distribution at half-point of Span 1 with machine at and concrete poured to three points on Stringer A.

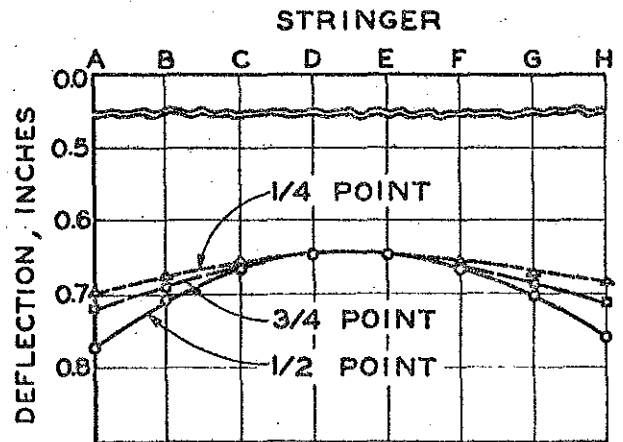

Figure 13. Transverse load distribution at half-point of Span 1 with machine at three points on Stringer A and the deck completed.

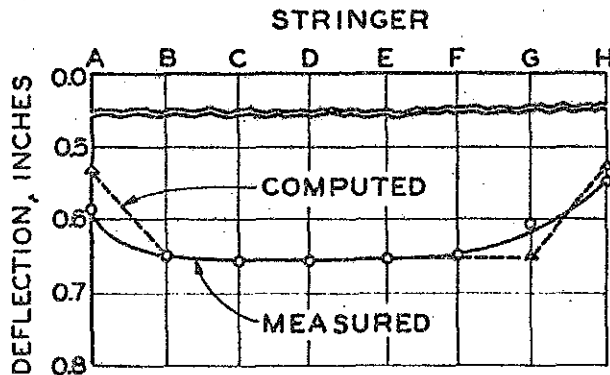

Figure 14. Computed and measured dead load deflection at half-point of Span 1.

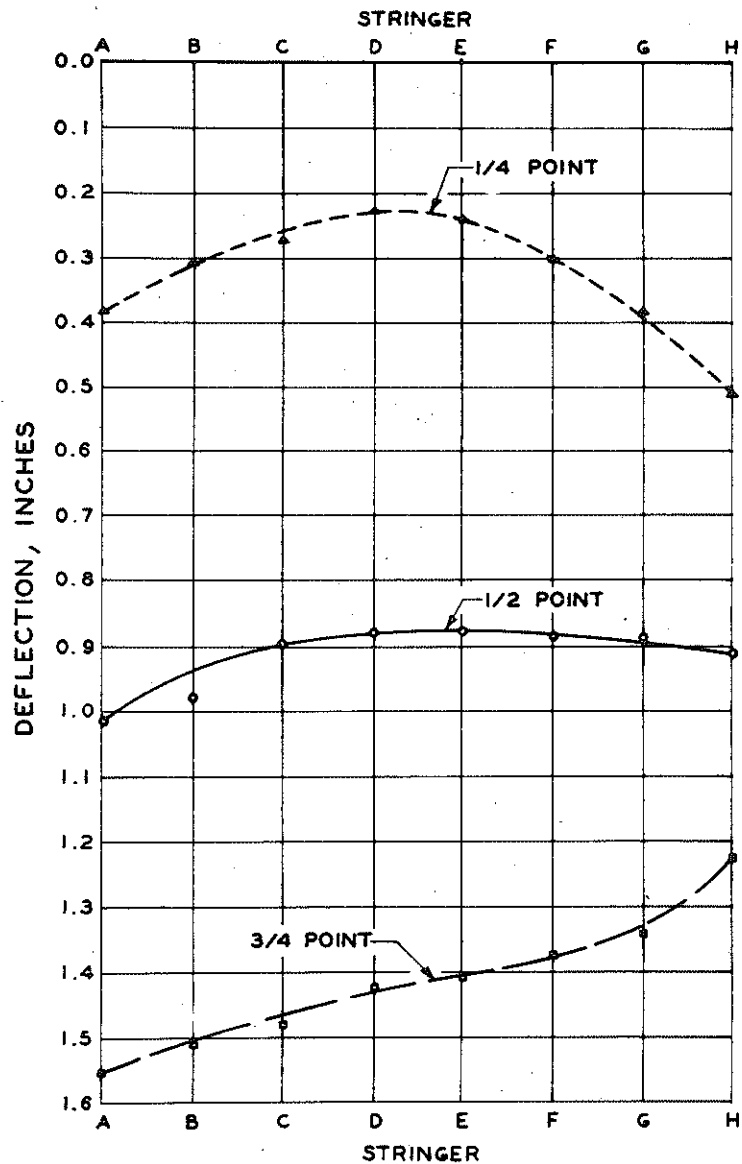

Figure 15. Transverse load distribution at half-point of Span 2 with machine at and concrete poured to three points on Stringer A.

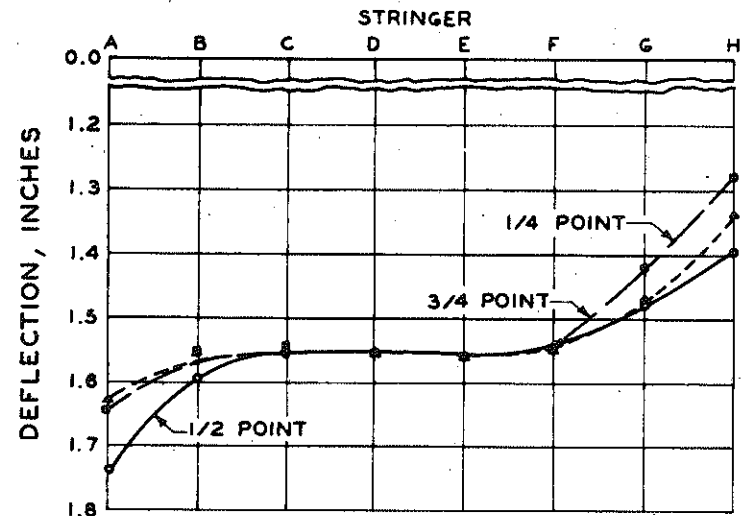

Figure 16. Transverse load distribution at half-point of Span 2 with machine at three points on Stringer A and the deck completed.

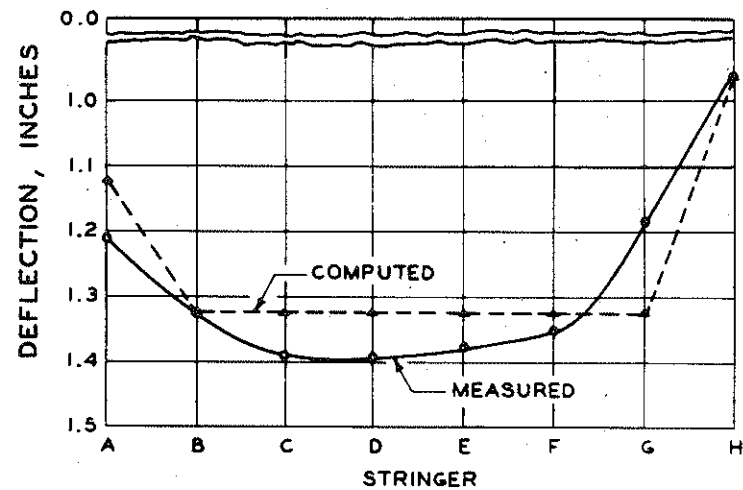

Figure 17. Computed and measured dead load deflection at half-point of Span 2, with deck completed on both Spans 2 and 3.

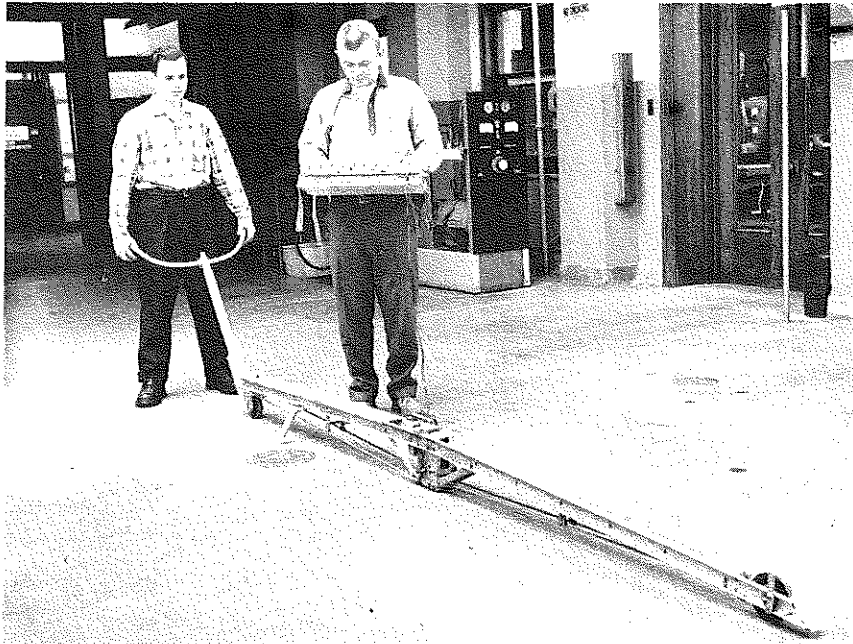
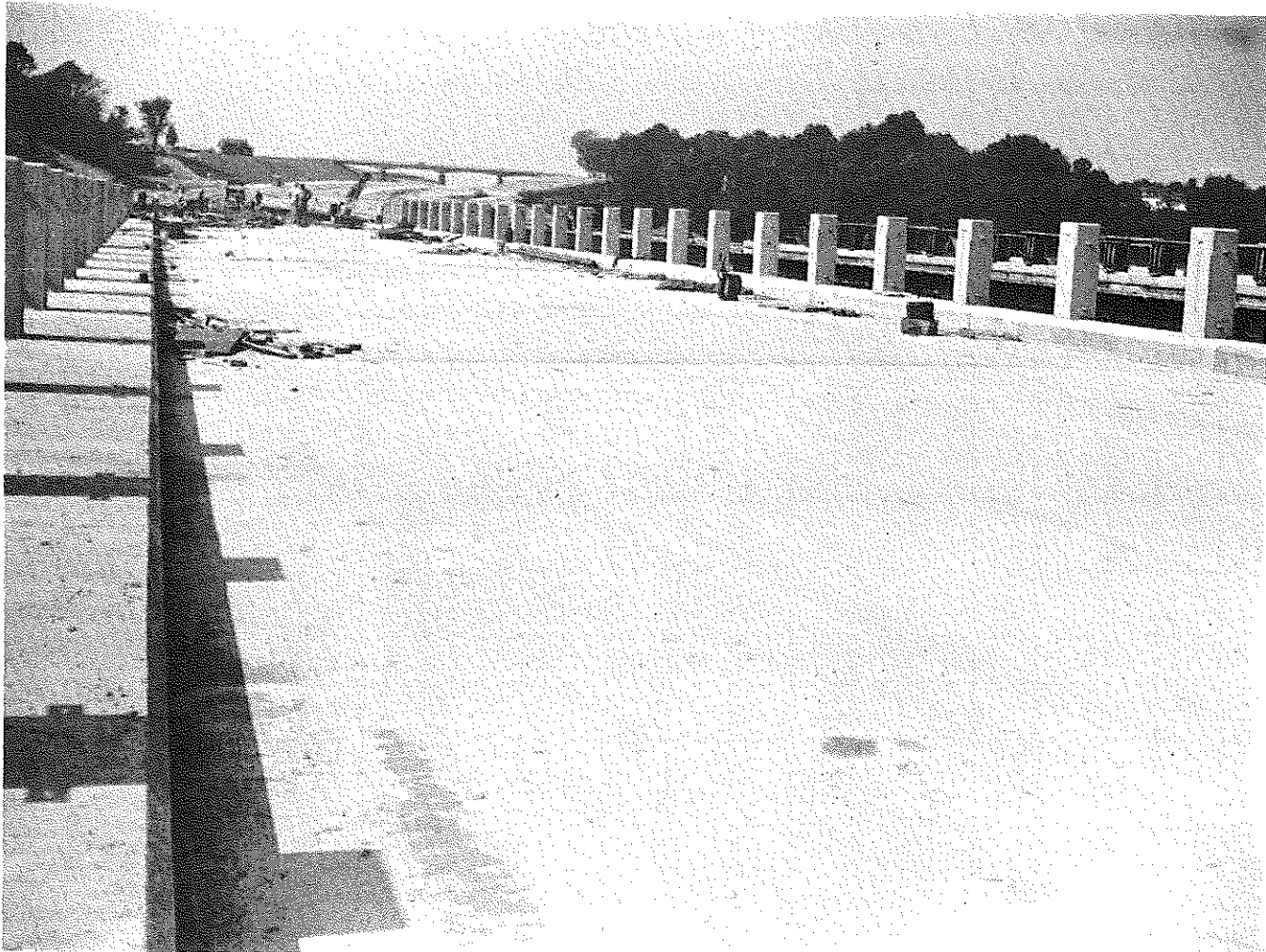

Figure 18. Rolling straight-edge profilometer.

Figure 19. Finished eastbound deck Spans 6 (foreground), 7, and 8.



An average roughness index was established for each bridge from the profilometer data, including two trials in each wheel track of each span. This average roughness index was obtained on two bases--including and eliminating all transverse joints. Comparison of these four bridges showed that the machine finished dual bridge, either including or excluding the transverse joints, had the roughest surface.

In addition, a riding quality survey was conducted by four persons from the Research Laboratory. Each operated the same vehicle on each bridge and ranked the bridges independently, according to his individual opinions. The resulting comparison was unanimous, and, with only one exception, agreed with the results obtained using the rolling straight edge profilometer. All agreed, however, that the machine-finished dual bridge had the poorest riding quality. These results are tabulated in Table 1, ranked from best to poorest.

The University of Michigan truck profilometer was also run on the eastbound machine-finished bridge, producing a roughness index of 197. This index is "very poor" in terms of a rating system in which indices over 200 are classified as "extremely rough."

The finished deck surface of Spans 6, 7, and 8 of the eastbound bridge are shown in Fig. 19. The surface roughness of the machine-finished bridge decks may be attributed largely to:

1. Newness of the operation for both the contractor's and the Departmental personnel, since for both agencies, this was the initial use of a finishing machine of this type.
2. Inability to provide a continuous flow of concrete to the machine.
3. Excessive short, repeated passes over the same section, thereby increasing the number of times the screed was removed and reset on the surface.
4. Use of a single oscillating screed in the finishing operation, tending to cause a rippling effect in the surface.

It is presumed, however, that with future modifications, and experience in the use of bridge finishing machines, the riding quality of machine-finished decks will steadily improve.

TABLE 1
BRIDGES RANKED BY COMPARATIVE DECK ROUGHNESS

Bridge No. and Location	Bridge Type	Bridge Length, ft	Rolling Straight Edge Index*				Riding Quality**	
			Without Joints		With Joints		Eastbound	Westbound
			Eastbound	Westbound	Eastbound	Westbound		
S21 of 11015 (formerly B3 of 11-18-6) I 94 over Lincoln Ave.	3 span, continuous T-beam	117	86	87	139	141	3.6	3.8
S02 of 11016 (formerly B1 of 11-17-6) Nickerson Rd. over I 94	4 span, continuous T-beam	264	143	121	157	145	1.8	1.8
S01 of 11016 (formerly B2 of 11-2-6) I 94 over M 139	4 span, simply supported rolled beam	229	172	162	196	197	5.1	4.8
B01 of 11016 (formerly B1 of 11-2-6) I 94 over St. Joseph river	8 span, overhanging and suspended rolled beam	644	225	200	241	213	7.7	7.1

* For comparison with roughness on six bridges reported in Research Report 325, "Roughness Measurements of Bridge Decks and Approaches" (March 1960), multiply by 1.56.

** Based on personal opinion using a scale with 1 as very smooth and 10 as extremely rough.