

NOTES:

- 1) All ground rods shall be 3/4"x10' copper clad rod a minimum of 2 ground rods shall be used (one for the service disconnect and one for the messenger cable & pole).
- 2) Ground rod placement shall not be less than 12" from the foundation with a minimum of 6' between ground rods. Placement shall be as directed by the Engineer and in compliance with N.E.C.
- 3) Ground wire connection to grounding rod(s) shall utilize a non-solder type connection.
- 4) Indicate the direction of conduits in foundation top with an arrow.
- 5) Install pole that the foundation & anchor bolts are plumb.
- 6) All grounds shall provide less than 10 ohm resistance to ground.

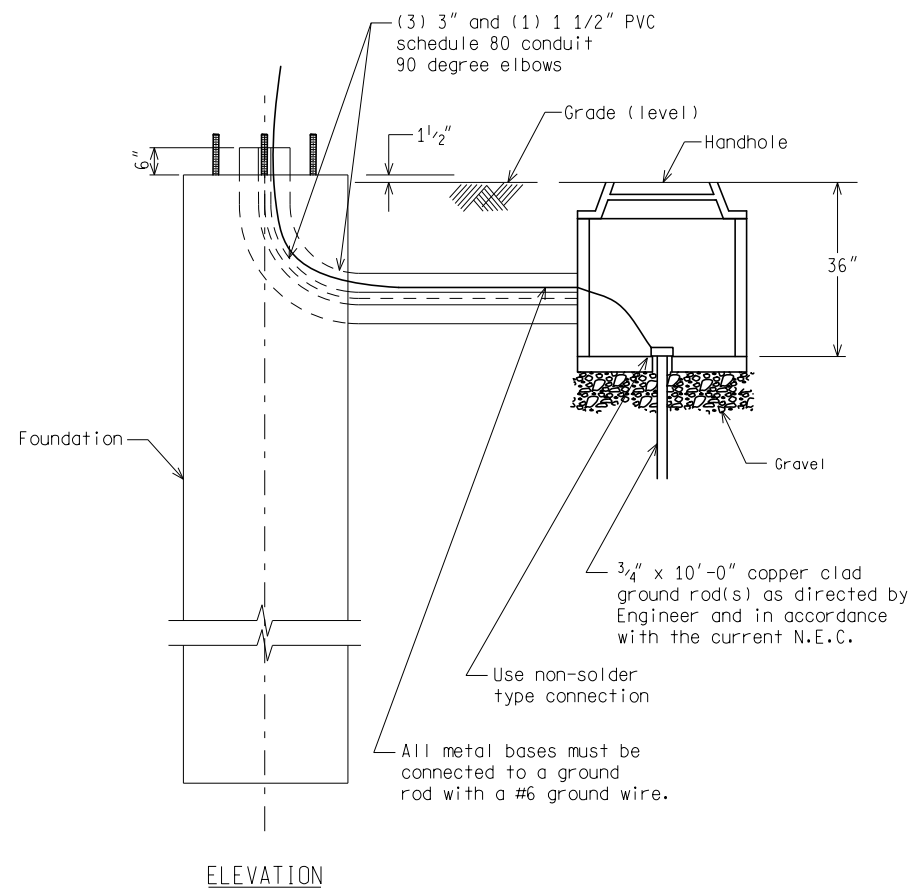
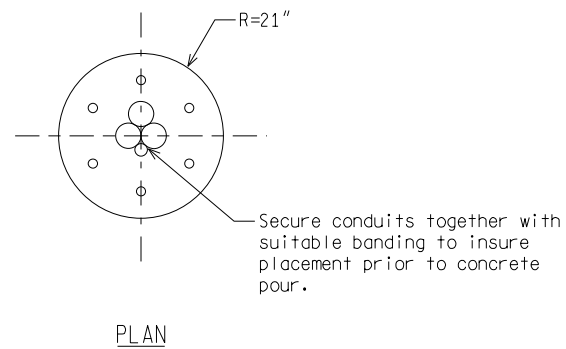

MAST ARM FOUNDATION CONDUIT AND GROUNDING

NOT TO SCALE

File: RefDoc/TR/Signals/Web/Sp Det/Fin/SIG040A.dgn Rev. 02/16/17



PREPARED BY  
TRAFFIC AND SAFETY

DRAWN BY:  
CHECKED BY:

ENGINEER OF DELIVERY  
  
ENGINEER OF DEVELOPMENT  
(SPECIAL DETAIL)  
FHWA APPROVAL DATE

MICHIGAN DEPARTMENT OF TRANSPORTATION  
BUREAU OF HIGHWAYS DELIVERY STANDARD PLAN FOR  
TRAFFIC SIGNAL MAST  
ARM STANDARD FOUNDATIONS

PLAN DATE SIG-040-A SHEET 1 of 4

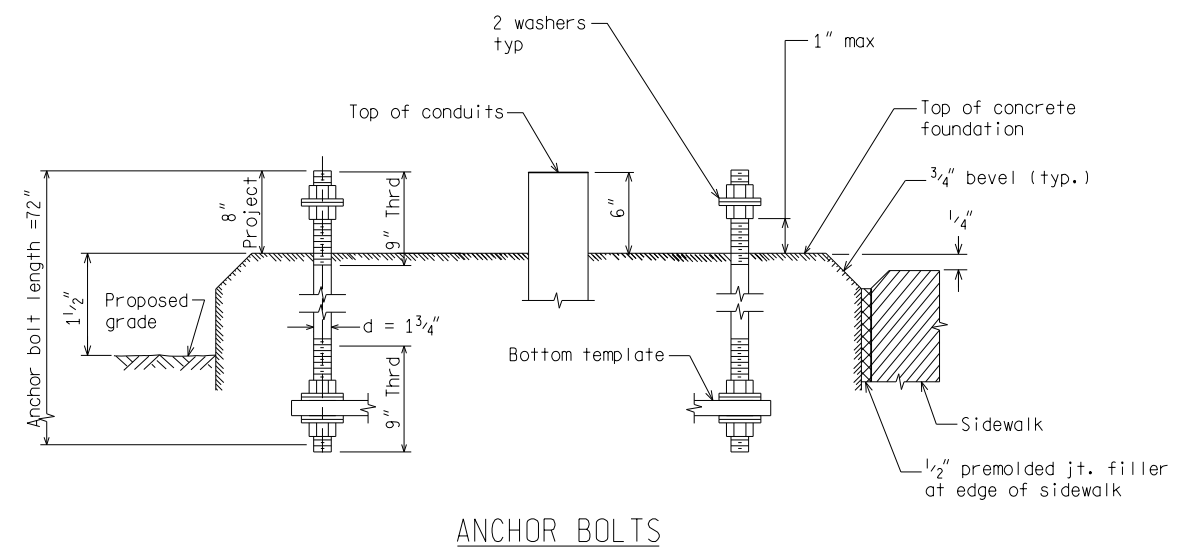

ANCHOR BOLTS

NOTE:  
Trench for placement of conduits after casing is in place and before dewatering.

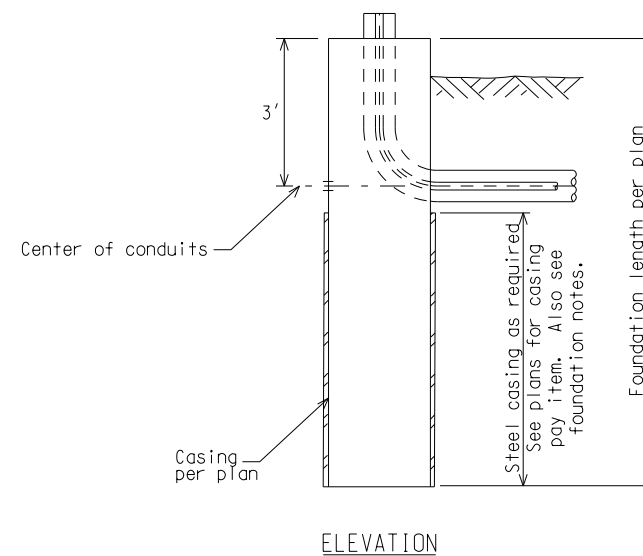
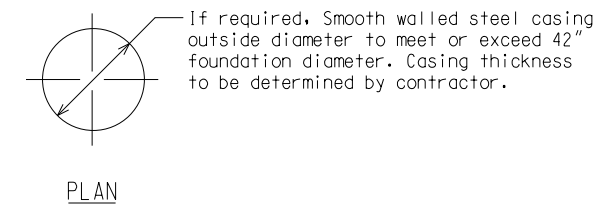

DRILLED FOUNDATION SHAFT (SHOWN WITH CASING PAY ITEM)

NOT TO SCALE

MICHIGAN DEPARTMENT OF TRANSPORTATION  
BUREAU OF HIGHWAYS DELIVERY STANDARD PLAN (SPECIAL DETAIL)  
FHWA APPROVAL DATE

File: RefDoc/TR/Signals/Web/Sp Det/Fin/SIG040A.dgn Rev. 02/16/17

PLAN DATE

SIG-040-A

SHEET 2 of 4

AS-LET PLAN REVISIONS

NO.	DATE	AUTH	DESCRIPTION	NO.	DATE	AUTH	DESCRIPTION



FILE:

DATE:  
DESIGN UNIT:  
TSC:

CS:  
JN:

DRAWING SHEET

NOTES:

- Anchor bolts shall be set and held vertical at the correct location and at the proper elevation with a 3/4" steel (or approved equal) template a minimum of 24 hours after the concrete placement has been completed.
- (6) 1 3/4" - 72" Anchor bolts with (4) Hex nuts and (4) washers per bolt.
- 24" dia bolt circle for Category I, Category II, and Category III Mast Arms.
- Mast arm orientation is not dependent on anchor bolt position.
- Use #4 AWG or larger standard bare ground wire bonded by mechanical connection to foundation reinforcing steel and having 24" of slack above the top of foundation.
- Galvanize all exposed nuts, bolts, and washers according to ASTM F2329. Galvanize all other steel items according to ASTM A123. Embedded nuts, bolts, washers, and steel ring need not be galvanized.

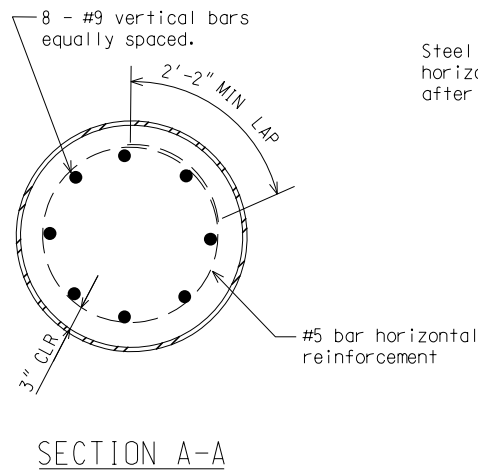
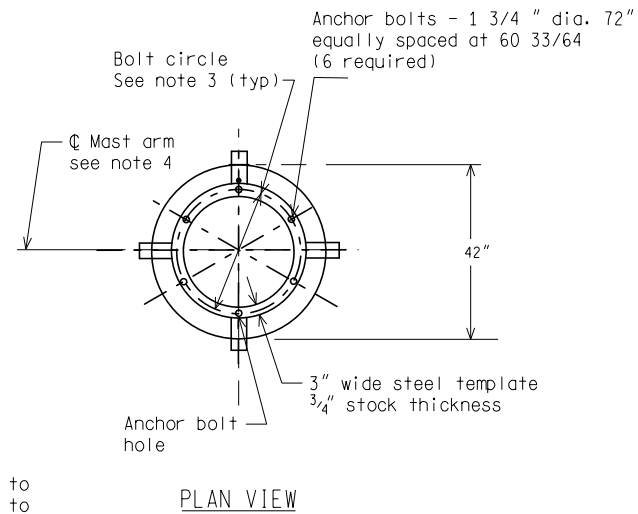

Steel template must be kept horizontal at all times after installation

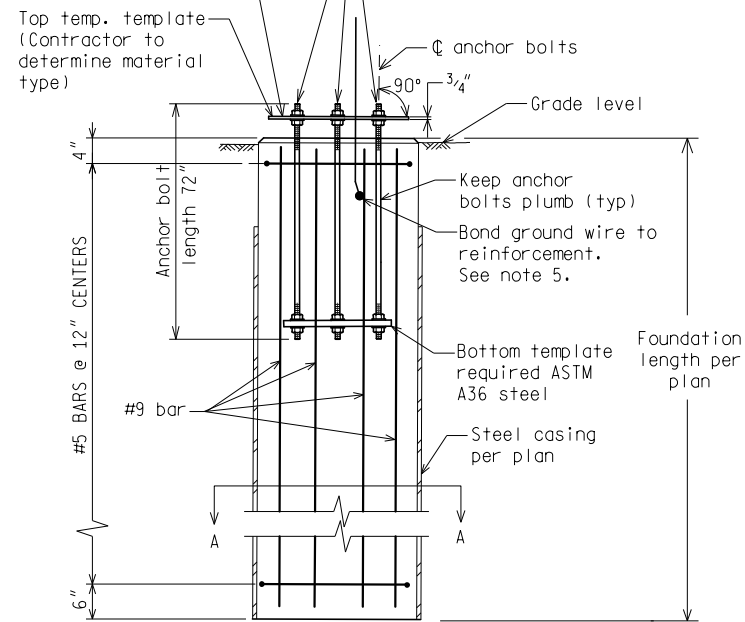

MAST ARM FOUNDATION (SHOWN WITH CASING PAY ITEM)

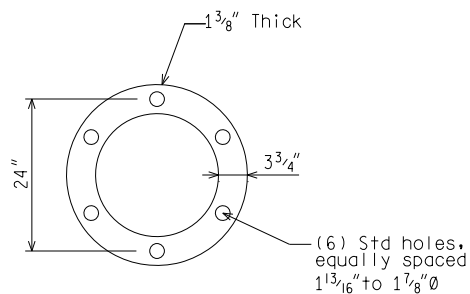

BOTTOM STEEL TEMPLATE

NOT TO SCALE

MICHIGAN DEPARTMENT OF TRANSPORTATION BUREAU OF HIGHWAYS DELIVERY STANDARD PLAN	(SPECIAL DETAIL) FHWA APPROVAL DATE		SIG-040-A	SHEET 3 of 4
File: RefDoc/TR/Signals/Web/Sp Def/F in/SIG040A.dgn	Rev. 02/16/17	PLAN DATE		

Foundation Notes:

- Refer to the following special provisions related to 6 anchor bolt mast arm poles:  
Traffic Signal Mast Arm Pole and Mast Arm Mast Arm Pole Foundation and Anchor Bolts Casing Used With Strain Poles and Mast Arm Poles
- Templates shall be shop fabricated and assembled prior to being approved by MDOT for shipping.
- Diameter of bolt holes in template shall be 1/16" larger than anchor bolt diameter.
- Conduits and anchor bolts shall be rigidly installed before concrete is placed. The center of the template shall coincide with the center of the foundation. The template and handles shall be well supported, horizontally level and firmly anchored in place a minimum of 24 hours after the concrete placement is completed.
- Due care shall be taken during the concrete placement to avoid displacing the anchor bolts.
- No hammering on the anchor bolts or template will be allowed.
- After template is removed, thread nuts on to the bolt flush with the bolt end to protect threads until signal support is erected.
- For anchor bolt material refer to section 908.14 A and B of the Michigan Standard Specifications for Construction. For anchor bolt installation and tightening refer to section 810.03 N.
- Dewatering of wet shafts is not allowed. A wet shaft is defined as having more than 3 inches of standing water or as having water infiltrating at a rate equal to or exceeding 12 inches per hour. For wet shafts, concrete is to be placed in accordance with section 718.03. (wet construction method) with a tremie tube or concrete pump beginning at the shaft bottom. Grade T concrete must be used for underwater placement. Grade S2 may be used in dry excavations only. See MDOT standard specifications Tables 701-1A and 701-1B (Concrete Structure Mixtures).
- Per MDOT standard specifications 718.02, the Grade S2 acceptable slump range is 6-8 inches. The Grade T acceptable slump range is 7-9 inches.
- If soil conditions indicate there is no need for a casing pay item as shown on the plans, the contractor should request permission of the engineer to install the foundation without casing.
- When the casing pay item is included on the plans for a foundation (due to granular soils or a wet hole), steel casing (smooth walled) is to be installed to enable the foundation to be poured. The thickness of the steel is to be determined by the contractor. The steel casing shall be left in place. A suitable method of compaction must be employed to ensure the soil immediately outside the casing is compacted properly.
- When the casing pay item is called for on the plans, the steel casing may stop at the conduit entrance to foundation. Top of foundation must then be formed separately. The casing pay item quantity will be paid for based on actual linear feet installed.
- Construct mast arm foundations, according to subsections 718.03 of the Standard Specifications for Construction. All work and materials shall be in accordance with the MDOT Standard Specifications.
- Steel reinforcement shall be ASTM A615 grade 60 without epoxy coating.
- Exposed concrete surfaces shall be cast in forms. Exposed concrete edges shall be beveled 3/4".
- Steel reinforcement shall have a clear cover of 3 inches unless noted otherwise. Steel Reinforcement may be adjusted to ensure proper clear cover.
- Grounding of pole includes adding #4 bare copper ground wire bonded by mechanical connection to foundation reinforcing steel and having 24" of slack above the top of foundation.

NOT TO SCALE

MICHIGAN DEPARTMENT OF TRANSPORTATION BUREAU OF HIGHWAYS DELIVERY STANDARD PLAN	(SPECIAL DETAIL) FHWA APPROVAL DATE		SIG-040-A	SHEET 4 of 4
File: RefDoc/TR/Signals/Web/Sp Def/F in/SIG040A.dgn	Rev. 02/16/17	PLAN DATE		

AS-LET PLAN REVISIONS							
NO.	DATE	AUTH	DESCRIPTION	NO.	DATE	AUTH	DESCRIPTION



DATE:	CS:	DRAWING	SHEET
DESIGN UNIT:	JN:		
TSC:			
FILE:			