

**LAST COPY**  
**DO NOT REMOVE FROM LIBRARY**

**LOAD TESTS OF THE ZILWAUKEE BRIDGE**  
**(Final Report)**

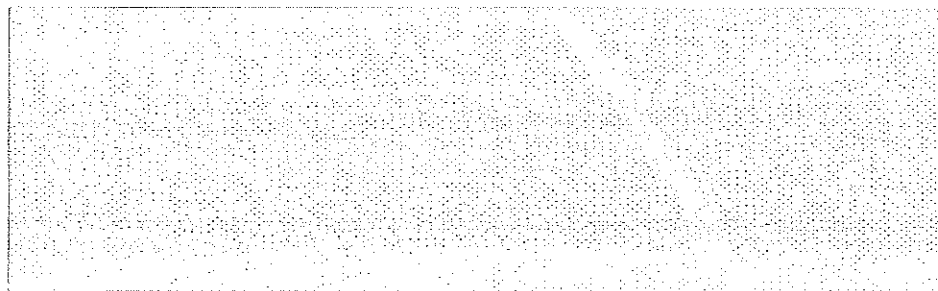

**MATERIALS and TECHNOLOGY DIVISION**



TG305 .K84 1987 c. 3  
Load tests of the  
Zilwaukee Bridge Final  
report

TG305 .K84 1987 c. 3  
Load tests of the  
Zilwaukee Bridge Final  
report

LOAD TESTS OF THE ZILWAUKEE BRIDGE  
(Final Report)

Sudhakar R. Kulkarni

Research Laboratory Section  
Materials and Technology Division  
Research Project 85 F-163  
Research Report No. R-1285

Michigan Transportation Commission  
William Marshall, Chairman;  
Rodger D. Young, Vice-Chairman;  
Hannes Meyers, Jr., Shirley E. Zeller,  
William J. Beckham, Jr., Stephen Adamini  
James P. Pitz, Director  
Lansing, November 1987

The information contained in this report was compiled exclusively for the use of the Michigan Department of Transportation (MDOT). Conclusions contained herein are based upon the load test data obtained, and expertise of the engineers of MDOT and CTL, Inc. No material contained herein is to be reproduced - wholly or in part - without the expressed permission of the Engineer of Materials and Technology, MDOT.

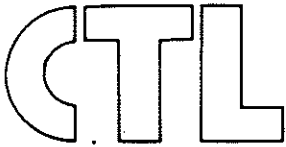

## construction technology laboratories, inc.

5420 Old Orchard Road, Skokie, Illinois 60077-4321 • Phone 312/965-7500 • Telex 9102401569 CTL.SKO • Easylink: 62200170

November 6, 1987

Mr. William J. MacCreery  
Deputy Director  
Bureau of Highways  
Michigan Department of Transportation  
425 West Ottawa  
Lansing, Michigan 48933

### Load Tests of Zilwaukee Bridge

Dear Mr. MacCreery:

Construction Technology Laboratories, Inc. (CTL) was hired by Michigan Department of Transportation to provide detailed engineering review of the Department's load testing of the Zilwaukee Bridge. Overall, our work has consisted of critically reviewing the test plan, witnessing the on-site load testing, reviewing the laboratory testing in Lansing, reviewing data reduction procedures, and evaluating the Final Report.

Construction Technology Laboratories is well equipped to oversee such testing. With almost 70 years experience and an internationally recognized technical staff, CTL is uniquely qualified for such activity. We have been actively involved in monitoring the performance of many long span bridges built in the United States in recent years. The structural testing on Zilwaukee Bridge represents one of the most comprehensive programs that we have ever been involved with on this type of bridge in North America. The results of the test program will provide all concerned with information concerning the performance of the bridge.

The tests were performed by the Michigan Department of Transportation on five selected spans of the bridge. The spans were selected to represent spans built under both contracts, spans damaged by spalling, undamaged spans, and the span involved in the 1982 construction accident. Each span was loaded with a vehicle and concrete segment having a total weight of approximately 258 tons. Response of each span to the test load was determined by measuring deflections and strains. Deflections across each span were measured using precise surveying instruments. Strains were measured at locations close to the pier and midpoint of each tested span. Strains were converted to stresses using the modulus of elasticity measured on concrete cores taken from the instrumented segments. Throughout each test, air and concrete temperatures were monitored so that temperature effects during each test could be identified. Tests of each span were witnessed by CTL staff. Procedures for data reduction were reviewed by CTL staff.

**construction technology laboratories, inc.**

Mr. W. J. MacCreery  
November 6, 1987  
Page 2

Theoretical structural response of the test spans to the test loads was calculated by Howard Needles Tammen and Bergendoff and supplied to the Michigan Department of Transportation. This included determination of deflection and stresses for comparison with measured data.

Based on the test program and analysis, it is CTL's opinion that the following conclusions as developed by the Michigan Department of Transportation represent a valid interpretation of the measurements.

1. Measured midspan deflections were less than calculated values.
2. Stresses determined from measured strains in concrete segments at the midspan location were less than calculated values. Stresses in the concrete segments at the pier were in reasonable agreement with the calculated values.
3. The entire cross-section of the segments contributed to the bending stiffness.
4. Measured concrete strengths at 28 days and at time of test were in excess of the specified design strength.

These conclusions show that the measured performance of the Zilwaukee Bridge was superior to, or at least equal to, the calculated performance.

Throughout the CTL review process, the Department has been completely open and has provided access to all records, test procedures, data sheets and evaluation procedures. Where appropriate, the Department has modified its plans to incorporate CTL's suggestions for improving the program. We believe that the work has been carried out in a very professional manner.

Based on the above, we find that Report No. R1285 entitled "Load Tests of the Zilwaukee Bridge" represents a true and valid statement of the testing and its conclusions.

Yours truly,



Dr. H. G. Russell  
Executive Director  
Structural Engineering Department  
HGR/aca

Copy to -  
Central Files  
CR-9515/821

SEAL:

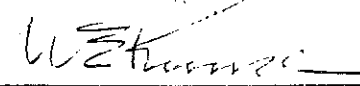
  
  
W. E. Kunze, President

## Load Tests of the Zilwaukee Bridge

- o Report Submitted By: Paul Milliman  
Engineer of Materials & Technology Division (M&T)  
Michigan Department of Transportation (MDOT)
- o Report and Testing Reviewed By: Dr. Henry G. Russell, S.E., P.E.  
Executive Director, Structural Engineering Department  
Construction Technology Laboratories, Inc. (CTL)
- o Research Effort Supervised By: Charles J. Arnold, P.E.  
Engineer of Research, M&T, MDOT
- o Report Written By: Dr. Sudhakar R. Kulkarni, Ph.D., P.E.  
Supervising Engineer  
Structural Research Unit, M&T, MDOT
- o Electronic Instrumentation and Strain Data Analysis Supervised By: Leo DeFrain, P.E.  
Instrumentation & Data Systems Unit  
M&T, MDOT
- o Design Representative, Contractor, and Construction and HNTB Consultant Coordination: William C. Turner, P.E.  
Segmental Concrete Bridges  
Design Division, MDOT

## ACKNOWLEDGEMENTS

The load testing of the Zilwaukee Bridge was completed by the Materials and Technology Division of MDOT. Construction Technology Laboratories, Inc. independently reviewed the test program, including this report. The author would like to acknowledge the assistance of a number of people who worked during the load testing as well as helped in preparation of this report.

Dr. Henry G. Russell of CTL, Inc. provided guidance during the entire process. His independent review was critical for completion of this report.

Charles J. Arnold directed M&T Division's role in performing the load testing. Research Section Units performed the following work:

The Structures Research Unit performed the deflection measurements, while the Instrumentation and Data Systems Unit carried out measurements of strains. The Materials Research Unit completed the testing of concrete cores. These three units were the backbone of the load testing program, and performed their roles in a professional manner.

William C. Turner of MDOT's Design Division and Gerald D. Dobie, Resident Engineer, Construction Division, helped to coordinate load testing at the bridge site. William C. Turner also helped write the chapter on long-term performance monitoring of the bridge. The bridge contractor provided the test load vehicle (Nooteboom) during the testing program. The Motor Carrier Division of the Department of State Police weighed the Nooteboom test vehicle before the start of the load testing program.

The engineering consulting firm Howard Needles Tammen and Bergendoff provided analytical/design values of deflections and stresses of the test spans in a timely manner.

During one of the load tests, reporters from newspapers and TV stations were invited to witness the testing. This provided a unique opportunity for communicating with the news media, which conveyed the information to the people of the State of Michigan.

In summary, the personnel of MDOT, CTL, Inc., HNTB, and the news media need to be thanked for this cooperative effort.

S. R. Kulkarni



## TABLE OF CONTENTS

	<u>Page</u>
<b>PART I</b>	
<b>INTRODUCTION</b> .....	1
Background .....	2
Objective .....	2
Scope .....	2
Selection of Test Spans .....	3
Load Test .....	5
1) Deflections .....	5
2) Stresses .....	6
3) Temperature .....	8
Analytical/Design Values .....	8
Long-Term Performance Monitoring .....	8
<b>LOAD TEST PLAN</b> .....	9
Test Load .....	9
Test Measurements and Procedures .....	9
Deflection .....	9
Stresses .....	11
Temperature .....	13
Concrete Properties .....	14
Theoretical Structural Analysis of Test Spans .....	14
<b>TEST MEASUREMENTS AND THEORETICAL RESULTS</b> .....	17
Deflections .....	17
Stresses .....	20
Concrete Properties .....	23
Discussion of Results .....	23
Deflections .....	23
Stresses .....	24
Concrete Properties .....	24
<b>LONG-TERM BRIDGE MONITORING PROGRAM</b> .....	25
Regular Maintenance Inspections .....	25
CMA Use and Latex Sampling .....	25
Elevation Monitoring .....	25
Future Load Testing .....	25
<b>SUMMARY AND CONCLUSIONS</b> .....	27
<b>REFERENCES</b> .....	29
<b>PART II</b>	
<b>TECHNICAL INFORMATION</b> .....	31
Precision Surveying .....	31
Bridge Instrumentation .....	33
Strain Measurement .....	33
Temperature Measurement .....	35
Strain Measurement Procedure .....	35
Calibration Procedure for Strain Measurements .....	36
Accuracy of Strain Measurements .....	37
Concrete Coring and Testing .....	37
<b>APPENDIX A - Nootboom Weighing Report</b> .....	39
<b>APPENDIX B - Measuring Equipment</b> .....	45

PART I  
INTRODUCTION

The Zilwaukee Bridge being built by the Michigan Department of Transportation (MDOT) will carry interstate highway I 75 over the Saginaw River (Fig. 1). The bridge will replace the existing drawbridge which causes massive traffic jams on I 75 when opened for navigational traffic. The Zilwaukee Bridge is a precast segmental concrete bridge, built of a series of high strength, reinforced concrete segments held together by tensioned high strength steel cables. The bridge segments were erected using a 'balanced cantilever' construction method, and the final segment was placed on September 24, 1987. The bridge is named after the nearby City of Zilwaukee and will be completed in 1988.



Figure 1. The nearly completed Zilwaukee Bridge and the existing bascule bridge it will replace.

Some of the important physical dimensions of the Zilwaukee Bridge are:

Length:	8066 ft northbound, 8090 ft southbound (total length 3.06 miles of northbound plus southbound)
Width:	70 ft 10 in. each roadway
Span Length:	Varying from 124 to 392 ft
Number of Spans:	25 northbound, 26 southbound
Underclearance:	125 ft over the Saginaw River for navi- gational purposes

This report contains the description, results, and conclusions of a load testing program for the Zilwaukee precast segmental concrete bridge. The report is divided in two parts. Part I is written in a simple, less technical style. It includes an introduction, test plan, results, summary and conclusions. It also describes a proposed plan for long-term performance monitoring of the bridge. Part II gives additional in-depth technical details of testing methods and load test results.

### Background

Erection of the segments of the bridge started in 1981. During August 1982, a construction accident caused a 300-ft section of the bridge deck to sag 5 ft on one end and rise 3-1/2 ft at the other end. The damage was repaired and construction progressed smoothly.

Since the accident, the question of the safety of the bridge has been raised by newspapers and television. In the summer of 1987, MDOT decided to perform a series of load tests of the bridge to resolve the safety issue.

### Objective

The objective of the load testing is to assure the structural sufficiency by comparing the test results with those computed by a design process, and at the same time, make provisions to monitor the bridge for evaluation of its long-term performance. To achieve the above objective, as well as to independently evaluate the load testing program, its results, and conclusions, the following agencies were involved.

MDOT retained the consulting services of Construction Technology Laboratories, Inc. (CTL), Skokie, Illinois. CTL is internationally recognized in the testing of concrete structures. CTL critically reviewed the experimental program, witnessed the testing and certified the results, and has reviewed this final report.

MDOT retained the consulting services of Howard Needles Tammen and Bergendoff (HNTB), an internationally recognized design firm for large concrete structures. HNTB provided the analytical/design values to compare with the experimental results.

Personnel of the Materials and Technology (M&T) Division of MDOT completed the load tests and collected the test results. The M&T Division also prepared this final report which was reviewed by CTL, Inc., as well as by the Design and Construction Divisions of MDOT.

### Scope

Considering the size and almost three-mile total length of the bridge's twin roadways, and on-going construction activity to complete the bridge, it was decided to load test five spans. These were Span Nos. 8, 12, 14, and 18 northbound and Span No. 18 southbound. Each span was tested separately, thus the entire test program involved five load tests.

A Nootboom truck, which was used to carry segments during construction, plus a bridge segment were selected as a test load. The Nootboom truck, plus a bridge segment weighed 258 tons. The same truck and segment were used during the entire load testing program. The test load is generally referred to as 'the Nootboom' throughout the report.

During a typical load test, deflection of the test span and strains in concrete segments near the mid-span and pier of the test span were measured when the Nootboom was centrally placed over the mid-point of the test span. During the test procedure, air and concrete segment temperatures were recorded to determine effects of temperature variations on the test results.

Concrete cores were removed from the instrumented segments adjacent to the gage locations near the mid-span and pier of the test spans to determine compressive strength ( $f_c'$ ) and modulus of elasticity ( $E_c$ ) of in-place concrete. These properties were used to compute stresses.

Selection of Test Spans - The selected five test spans represent combinations of various construction events. Spans were selected from both construction contracts, and both the northbound and southbound bridges. One of the spans (12N) selected for evaluation was the one involved in the construction accident in 1982. Another selected span (8N) was one of the most affected by spalling during the winter of 1986, and the remaining spans were typical comparable spans. The selected test spans as well as location of the instrumented segments (segments with strain gages) are shown in Figures 2 and 3.

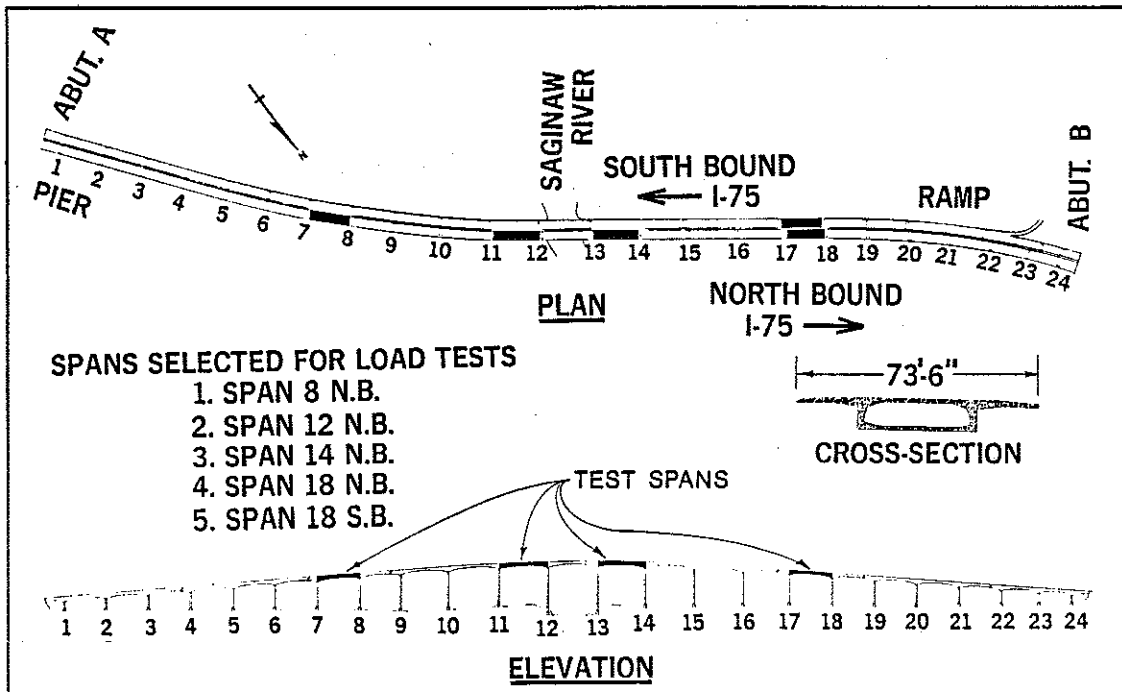

Figure 2. Location of the test spans. Span Nos. 20 through 25 southbound, Nos. 11 through 24 northbound, and parts of Nos. 9 and 10 northbound were constructed under the old contract. All remaining work is under the new contract. The contractors for the old (10/2/79 - 8/5/83) contract were Steven and Toebe, and for the new (11/16/84) contract, S. J. Groves & Sons.

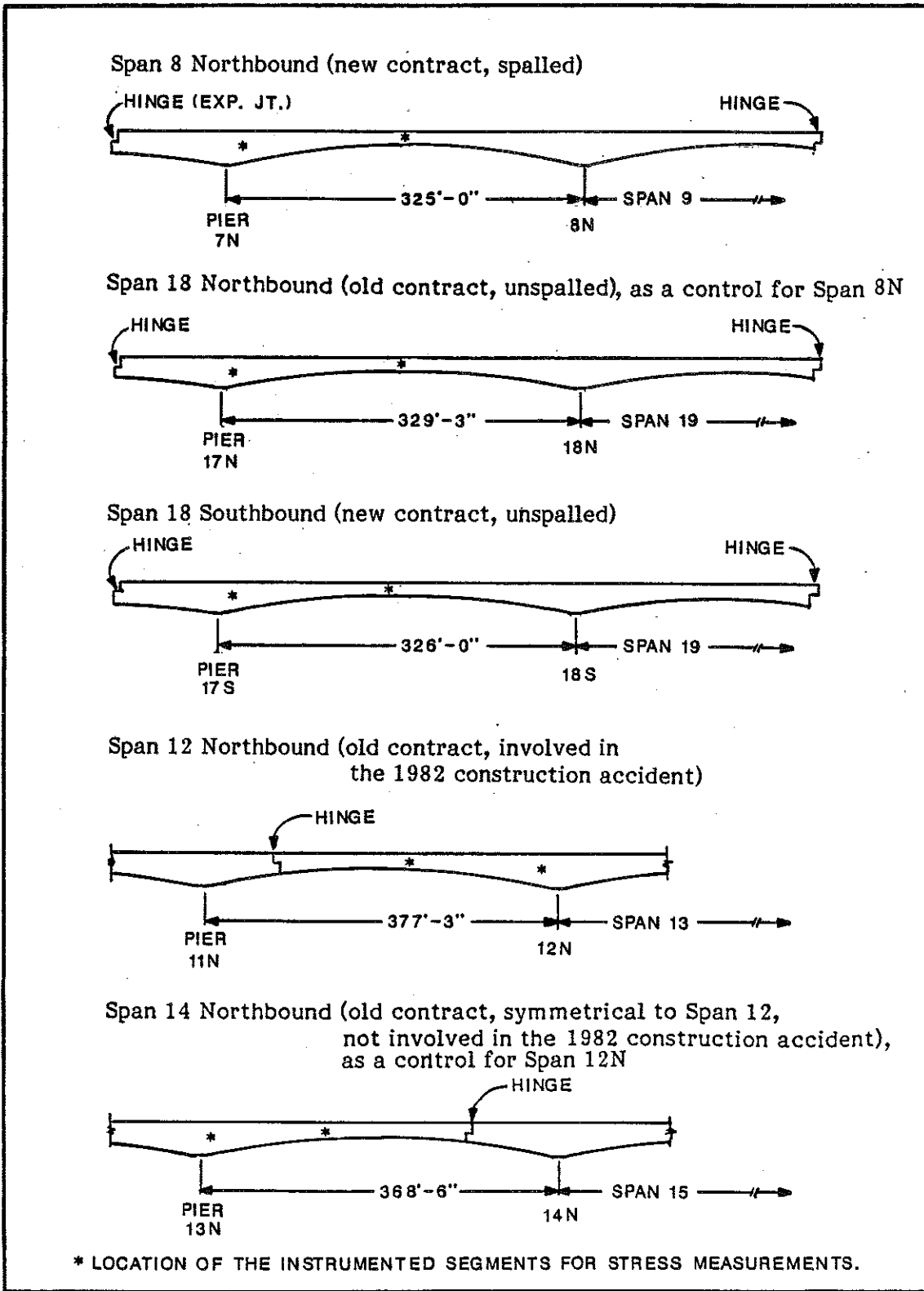

Figure 3. Test span descriptions.

Load Test - Strength can be defined as the ability of the bridge to resist force. The 'force' in this case was a vehicle (Nootboom) carrying a concrete segment across the bridge. The vehicle and segment, shown in Figure 4, weighed 517,350 lb or about 258 tons.

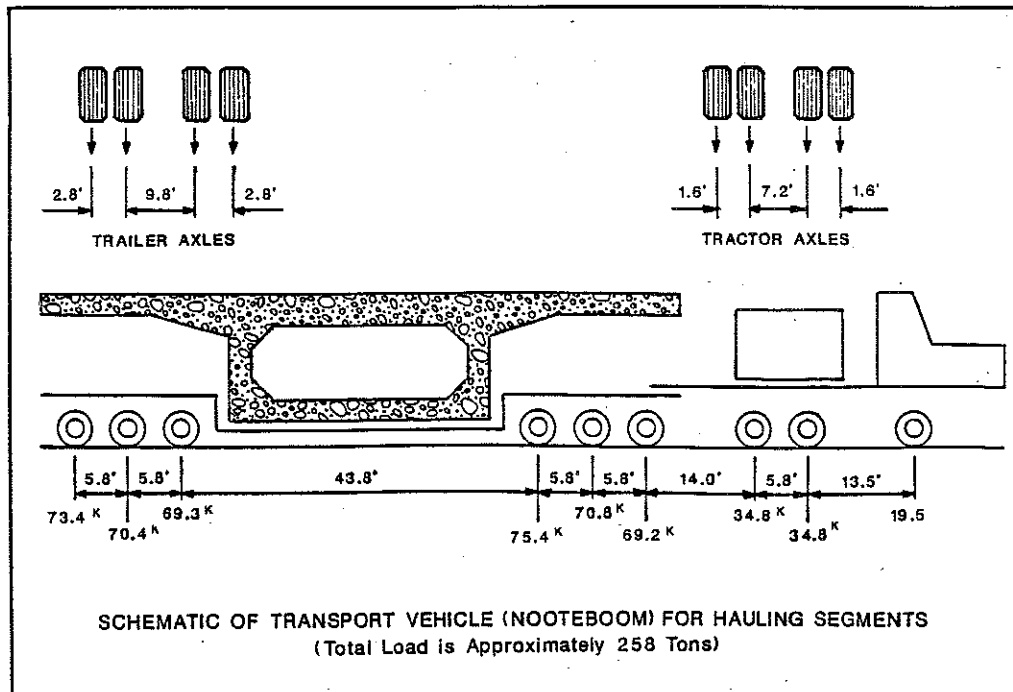

Figure 4. The Nootboom test load.

The indicators of structural performance evaluated for the bridge were: a) downward deflection or bending of the bridge span between piers; and, b) intensity of tensile and compressive stresses in the concrete at critical locations along the span due to the test load.

1) Deflections: Deflection of a bridge span is its bending downward due to the load of the vehicle (Fig. 5). Usually, deflections are measured in units of inches. The total amount of deflection depends on the amount of load and its location on the span, the distance between supports (span length), the strength of the concrete used, and the size and shape of the beam. In the present case, the amount of expected deflection for each tested span was calculated and compared to the measured results.

Precision surveying instruments were used to measure the elevations of reference points on the top of the segments at regular intervals along the test span. Elevations at these selected reference points were recorded when the Nootboom was not on the span. Then the Nootboom was moved to the middle of the span and the elevations of the same reference points were measured again. The elevations were measured to 1/1000 of a foot. The difference between these elevations gave the deflection of the span. The maximum deflection at the mid-span occurred when the Nootboom was also placed at

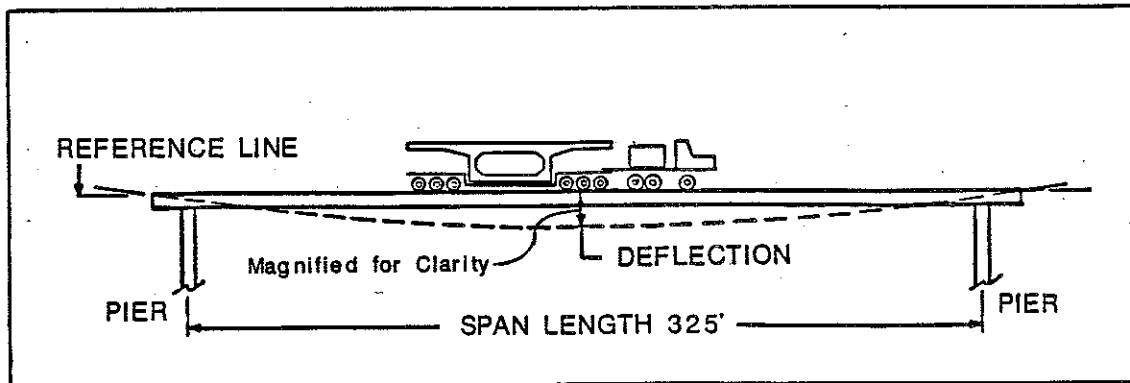

Figure 5. Span deflection under load.

the mid-span. Elevations of the selected reference points were measured after the test load was removed from the test span to record rebounding of the span.

A high precision surveyor's level was used for the measurements along with a special level rod made of a material called Invar. This material exhibits extremely small changes in length during heating and cooling so that air temperature changes do not significantly affect the length of the measuring rod.

2) Stresses: Stresses (intensity of forces) in the concrete were determined by the amount of stretching or shortening (strain) of the concrete and a property of the concrete called the modulus of elasticity,  $E_c$ . The mathematical relationship between stress and strain is:

$$\text{Stress} = E_c \times \text{Strain}$$

By knowing the property of concrete,  $E_c$ , and measuring the amount of stretching or shortening (strain) of the concrete, the stresses (intensity of forces) were computed.

Concrete cores were removed from the instrumented segments of the test spans. Compressive strength ( $f_c'$ ) and modulus of elasticity ( $E_c$ ) of concrete were determined by the M&T Laboratory. The standard American Society for Testing and Materials (ASTM) and MDOT procedures were followed to perform these tests. The test results are included in later sections.

Strains were measured in concrete segments near the mid-span and piers of the test spans. Strain gages were firmly cemented to the segments and used to measure how much the concrete in the test span was compressed or stretched at these locations when the Nootboom was moved slowly across the test span of the bridge. The strain gages, very sensitive devices, were attached to the segment and connected to electronic instruments such as amplifiers and recorders. The instruments applied the necessary electrical power to the strain gages, and amplified the signals due to stretching or compression of the strain gages, and recorded the results (Fig. 6).

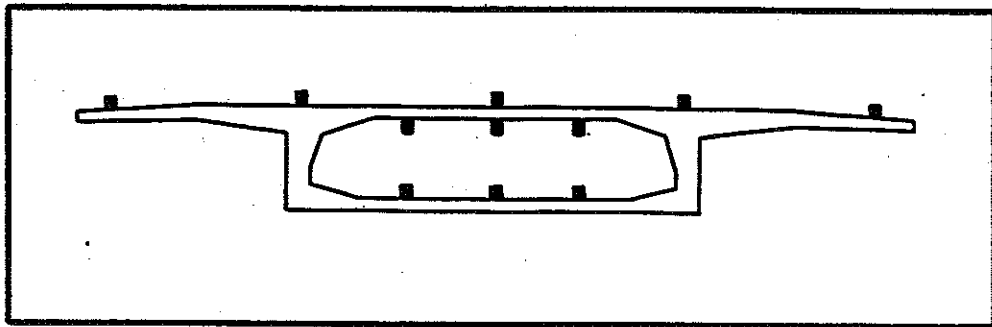

Location of strain gages.

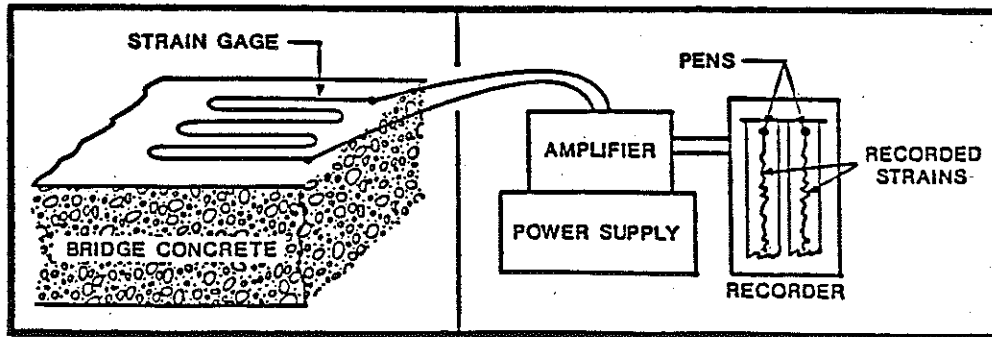

Strain gage and electronic circuit set-up.

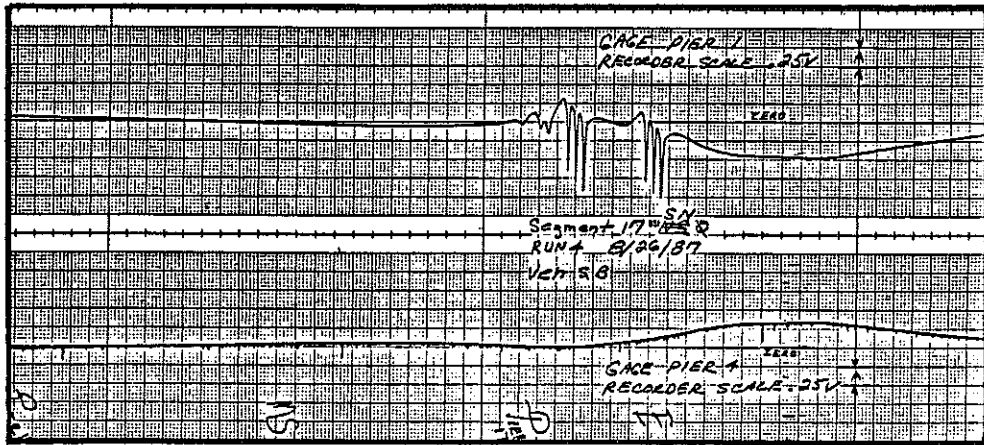

Strain gage recorder output.

Figure 6. Strain gage locations, electronic set-up, and a trace showing strain gage recorder output.



A strain gage consists of a very thin and precisely made metal foil that is placed on a plastic film. The gages used in this study were 4 in. long and 1/2 in. wide. Gages were bonded to the bridge at critical locations with special cements. Wires were soldered to the gages and waterproofing compounds were applied to protect the gages and connections. When the bridge deck concrete was stressed under the test load, the lengths of the strain gages changed and so did their electrical resistance. These small changes in resistance caused tiny changes in current that were amplified many times over, using electronic amplifiers, and finally displayed on a recorder (Fig. 6). The system was so sensitive that it could sense a change of one millionth of an inch in the 1-in. length of concrete under the strain gage.

3) Temperature: Bridge movement also can be caused by changes in temperature. Therefore, temperature sensors were used to monitor concrete temperature at various locations on the test spans of the bridge structure. Temperatures were measured using small devices called thermocouples, and were recorded on a chart recorder. For the duration of most of the testing periods, variation in bridge deck temperature was less than 4 degrees, thus the effect on the test results was minimal.

Analytical /Design Values - The analytical/design values of the deflections and stresses were obtained using modern engineering analysis methods and computer programs. These values were provided by the design engineers of HNTB using their in-house version of STRUDL, a structural analysis computer program. A comparison of measured and theoretical (computed) deflections and stresses of the five test spans is presented in Section 3, "Test Measurements and Theoretical Results."

#### Long-Term Performance Monitoring

Provisions to monitor long-term performance of the bridge are being finalized. This will include monitoring vertical deflections (bridge profile) of the bridge deck due to shrinkage and creep properties of the concrete. A reference data bank will be established before the bridge will be opened to traffic. For additional details, refer to Section 4, "Long-Term Bridge Monitoring Program."

## LOAD TEST PLAN

This section describes the test load, test measurements and procedures for deflections, stresses, temperatures, and concrete properties. The theoretical structural analysis procedure which is used to compute design values of deflections and stresses is briefly described.

### Test Load

As the Nootboom was being used to carry segments for on-going bridge construction activity, it was selected as the test load. The test load not only provided approximately 258 tons of weight, but the mobility of the load facilitated the testing program, and saved valuable time. The test load was weighed by the Motor Carrier Division of the Department of State Police. Refer to the Appendix for the Nootboom weighing report.

A comparison of the test load with the design load and the heaviest truck load on Michigan's highways is shown in Figure 7. The design of the superstructure (deck) of the bridge is based on 'HS-25 loading.' The Figure shows the HS-20 and HS-25 truck loadings, 82-ton maximum weight truck allowed on Michigan's interstate highways, and the Nootboom, for comparison.

The bridge was checked during the design phase to assure that it has the ultimate capacity to carry more than twice the design traffic load. The ultimate live load capacity of one typical span is more than three times that represented by the test load.

### Test Measurements and Procedures

The load tests for the selected five spans were completed during the summer of 1987. Each span was tested separately and, on the average, required about 1-1/2 days. The process of instrumenting the test span started a few days earlier. This included attaching strain gages to the segments near the mid-span and pier, wiring, connecting gages to power source, amplifiers, and recorders. The amplifiers and recorders were placed in a van on the bridge deck. Thermocouples were attached to a segment near the mid-span to measure concrete temperatures.

The test measurements included deflections, strains, temperatures, and concrete properties. The deflection and strains were recorded during the load tests. The temperature of the deck concrete and air were measured for a period of 24 hours. The temperature measurements were started before loading of the test span and continued a few hours after the span was unloaded. Concrete properties ( $f_c'$  and  $E_c$ ) were subsequently determined by removing cores from the instrumented segments and testing these cores in the M&T Laboratory. The strains were converted to stress by using the following relationship:  $\text{stress} = E_c \times \text{strain}$ .

Deflection - Deflections of a test span due to the test load were measured at intervals (approximately 1/8 span length) along the span. The following steps were used to measure deflections:

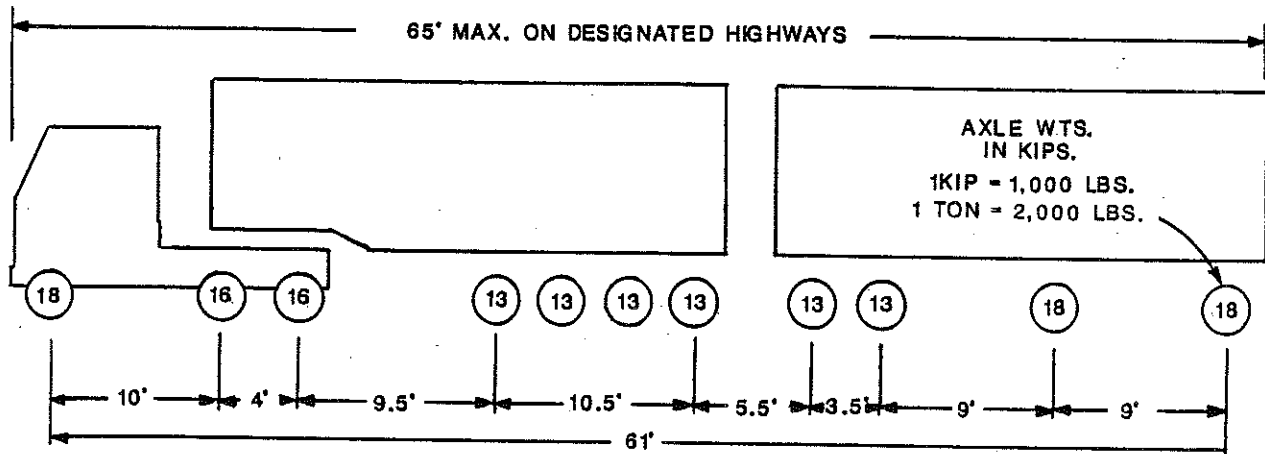
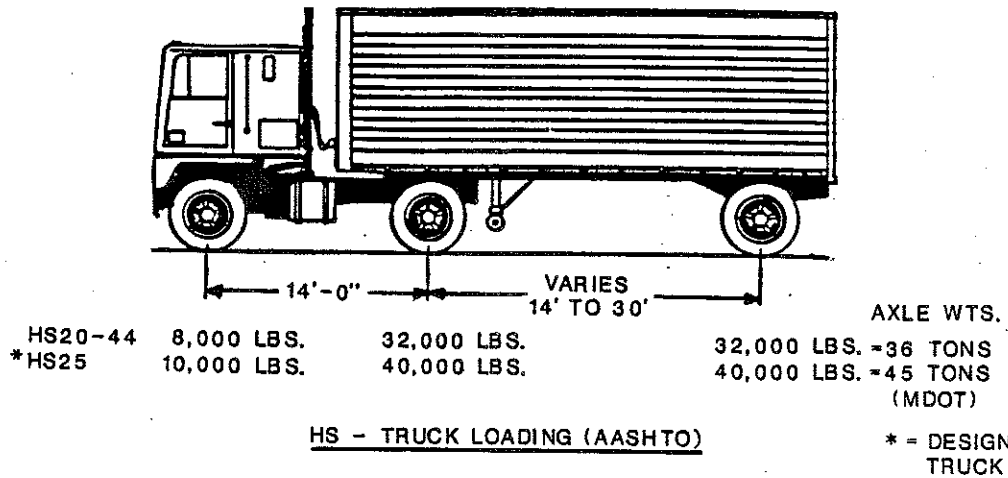

MICHIGAN 11 AXLE THREE UNIT MAX. 82 TONS

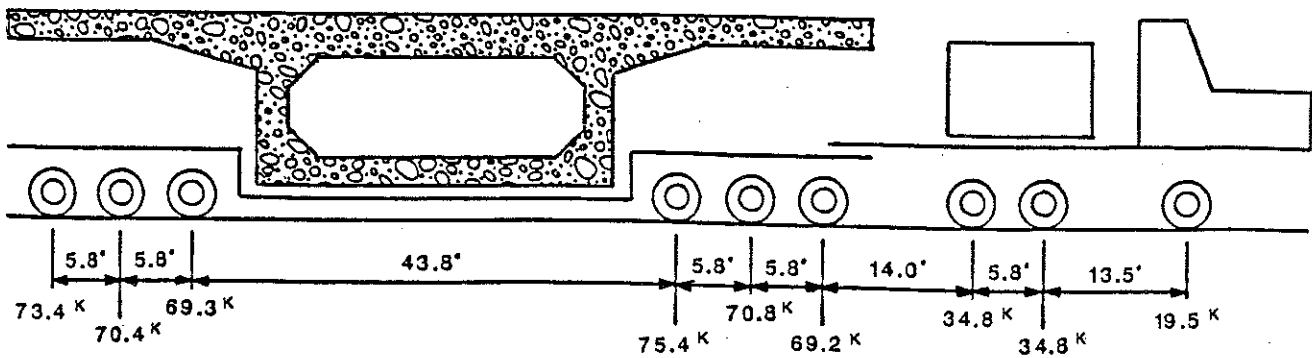

SCHEMATIC OF TEST LOAD (NOOTEBOOM)  
 TOTAL LOAD IS 258 TONS

Figure 7. Comparison of AASHTO 'HS' truck loading, an 11-axle, three-unit maximum allowable vehicle in Michigan, and the Nootboom test load.

- a) Using precision surveying instruments (level and rod) elevations of points on top of the deck slab were determined when the test load was off the bridge. The points were set at intervals in the slab (over the web) using stainless steel pins for accurate reference.

The deflection was computed as an average of deflections of points L and R (Fig. 8).

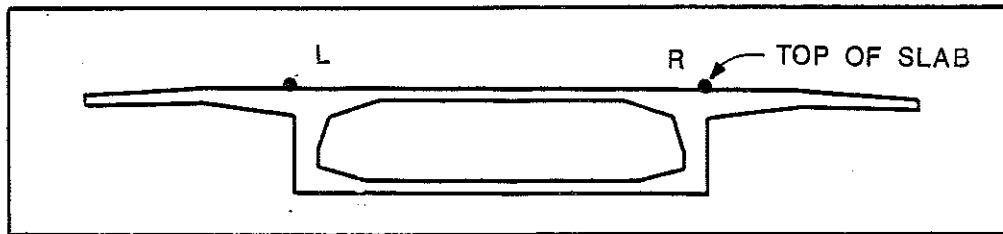

Figure 8. Points on deck for elevation measurements.

- b) The test load was then driven slowly to the mid-point of the test span and centered over it.
- c) The elevations of the above points were remeasured. (Steps a through c required about two hours.)
- d) Deflections of these points along the test span were computed as a difference between elevations determined in steps a and c.

The elevations of the span were recorded again after the test load was moved off the span. These elevations were used to determine rebound of the test span.

- e) The air and concrete temperatures were monitored every 15 minutes for a 24-hour period and elevations about every 3 hours for the test span (with no test load on the span) were recorded at regular intervals. These elevations were used to compute deflections due to concrete temperature variations.
- f) The deflections due to the test load were corrected for the effect of concrete temperature variation during the time required to complete steps a through c.
- g) A comparison of the measured deflections (Step f) and computed design deflections is presented in Section 3.

Stresses - The stresses (load intensity) in pounds per square inch (psi) in concrete segments were computed using:  $\text{Stress} = E_c \times \text{strain}$

where  $E_c$  = Modulus of elasticity of concrete in psi  
 strain = Concrete strain measured by the strain gages (in./in.)

Strain is defined as change in length divided by the original length as shown in Figure 9.

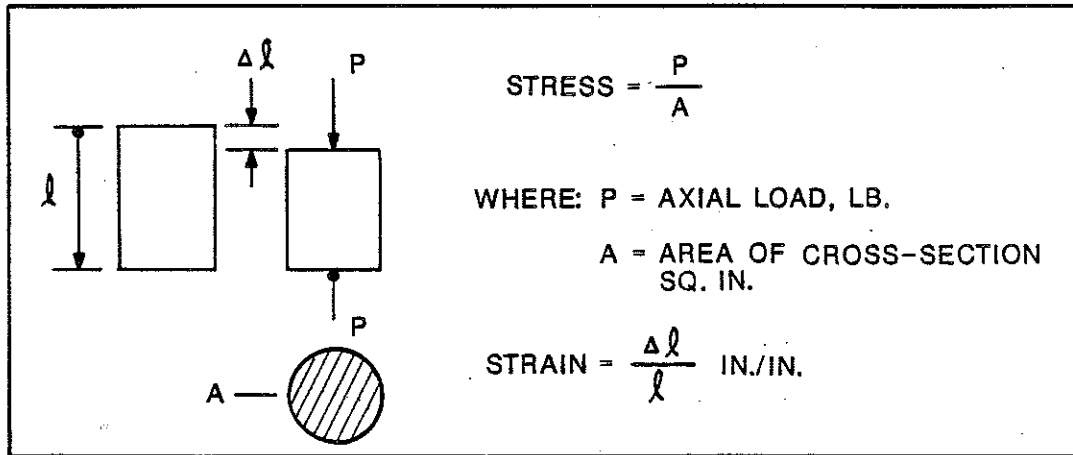

Figure 9. Strain and stress.

The modulus of elasticity can be computed using:

$$E_c = W_c^{1.5} \times 33 \sqrt{f_c'} \quad (\text{AASHTO 8.7})$$

where  $W_c$  = unit weight of the concrete in lb/cu ft  
 $f_c'$  = 28-day compressive strength of concrete in psi

Using normal-weight of concrete = 150 lb/cu ft

$$E_c = 60,625 \sqrt{f_c'}$$

$$= 4.7 \times 10^6 \text{ psi for } f_c' = 6,000 \text{ psi}$$

Strain gages were used to measure strains in the segments near the mid-span and pier locations. Figure 10 shows location of strain gages on the instrumented segment. Due to ease of access and no disturbance from on-going construction activity, the strain gages (1 through 6) were placed on the inside surfaces of all the segments. During load test of Span 18S the gages (7 through 11) were placed on top of deck slabs. The gages (7, 8, 10, 11) on the wings were placed to give information about stresses in the wings. After reviewing the data from this test, during subsequent load tests gages on the wings were not used. This helped to reduce the number of chart recorders needed during the load test. At least one gage on top of the bridge deck was used during subsequent load tests of the northbound bridge. Due to difficulty of accessing the bottom of the segment, no gages were placed. The bottom of the segments of the test spans is at least 100 ft above ground level.

Strain measurements were started before the test load reached the bridge and continued as it slowly travelled from one end of the span and was parked at the mid-span to measure deflections. The first strain measurements (static)

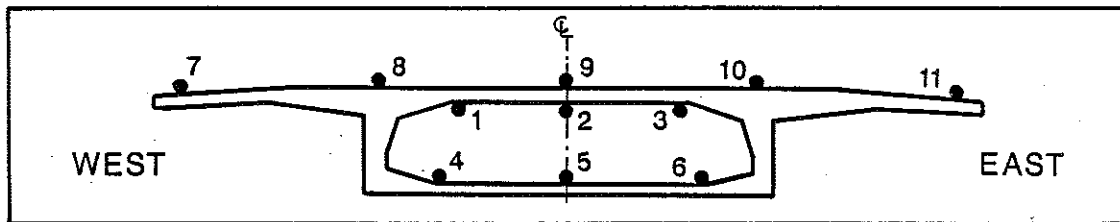

Figure 10. Location of strain gages on segment.

were completed. The test load was then moved off the span. The test load then made three passes across the test span and rolling strain measurements were repeated each time. The strains were continuously measured as the test load travelled slowly (3 mph) from one end of the test span to the other. Static strain values were used to compute stresses at the gage locations.

A comparison of stresses determined from measured strains and computed stresses in the instrumented segments of the test spans is presented in the next section.

Detailed descriptions of instrumentation, process of recording data, and converting strain data to stresses are given in Part II.

Temperature - The temperature of the concrete segment near the mid-span and of the air were recorded during the tests. Thermocouples were used to measure the temperature. The thermocouples were connected to a temperature digital recorder. The temperatures were recorded every 1/2 hour during the 24-hour test period. Figure 11 shows the location of thermocouples on a segment.

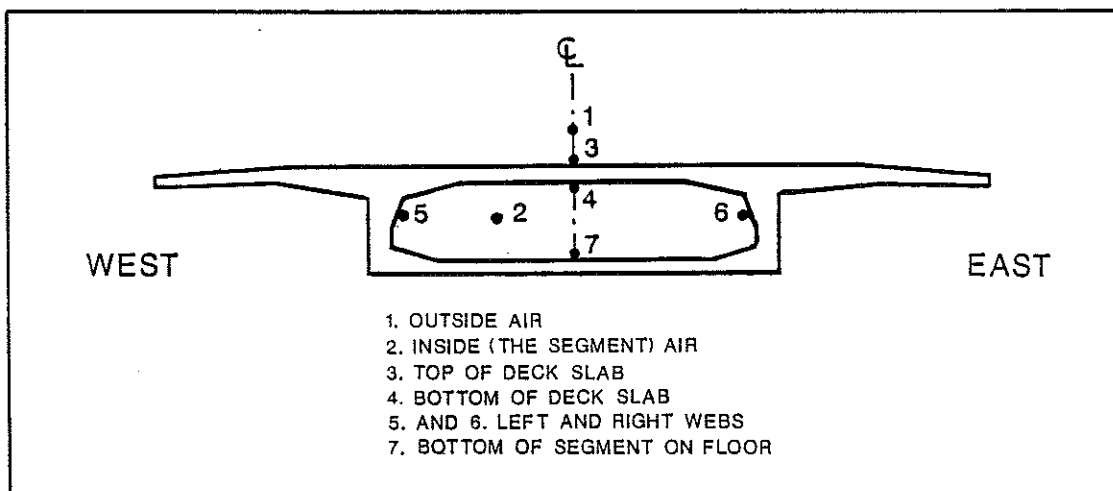

Figure 11. Location of thermocouples on segment.

Concrete Properties - Compressive strength ( $f_c'$ ) and modulus of elasticity ( $E_c$ ) of concrete were determined by testing the cores taken from the instrumented segments. These values are shown in Table 1.

TABLE 1  
CONCRETE CORE TEST RESULTS

Sample No. <sup>1</sup>	Location of Core Sample		Compressive Strength, psi	Modulus of Elasticity, psi
	Span	Segment		
1	8N	7NNB	6270	$4.6 \times 10^6$
2	8N	7NNQ	6750	$4.5 \times 10^6$
3	12N	12NSF	8070	$4.7 \times 10^6$
4	12N	12NST	8960	$5.0 \times 10^6$
5	14N	13NNG	8620	$5.2 \times 10^6$
6	14N	13NNT	8570	$5.5 \times 10^6$
7	18N	17NNB	7810	$5.0 \times 10^6$
8	18N	17NNQ	7470	$4.9 \times 10^6$
9	18S	17SNB	8290	$5.0 \times 10^6$
10	18S	17SNQ	7100	$4.7 \times 10^6$
		Average	7800	$4.9 \times 10^6$

<sup>1</sup>Typical core sample is 3.83-in. diameter and 8.0-in. length.

The compressive strength,  $f_c'$ , of the cores was determined following ASTM C-42 procedures. Similarly, modulus of elasticity,  $E_c$ , was determined by following ASTM C-469 procedures.

#### Theoretical Structural Analysis of Test Spans

Theoretical structural analysis of a structure (bridge) is performed to compute internal forces such as axial force (tension-compression), moment, and shear in the members of the structure as well as its deflection due to external loading. The physical make-up, geometry of the structure, as well as properties of materials used for the structure need to be taken into account for analysis. Recent advances in computerized methods of structural analysis provide a time-saving and accurate tool for bridge design engineers.

In performing the analysis, i.e., computing design values of deflections and stresses of the test span, the following procedure was used:

- a) A computerized structural analysis method was used. Each span was divided into a number of elements (equal to segments in the span). Data input included geometry, section properties based on plan dimensions of the segments, concrete properties, and loading. The program output included deflection and stresses of the span. See Ref. 1 for additional details.
- b) When analyzing the test span, several adjacent spans on each side were included to take into account effects of continuity of the bridge deck. The piers were not included in the analysis.
- c) Concrete properties used:  $f_c' = 6000$  psi 28-day compressive strength  
 $E_c = 4.7 \times 10^6$  psi
- d) External loads were due to wheel loads of the Nootboom carrying a segment and placed over the mid-span location. The computer analysis applied loads at the segment joints. The Nootboom wheel loads, which were not at the segment joints, were converted to a fixed-end force set applied at the segment joints.
- e) It was assumed that 1-1/2 in. latex concrete wearing surface and the barrier walls did not contribute toward bending strength and stiffness of the test span. This is a conservative approach, and is a typical assumption made in this type of design work. If the wearing surface and barrier walls are considered to be structurally active parts of the bridge, it will be stronger and stiffer than designed.
- f) The computer program provided stresses and deflections at the joints between segments. Computed stresses at the actual gage locations were determined by linear interpolation.



## TEST MEASUREMENTS AND THEORETICAL RESULTS

This section includes the load test measurements for the five test spans. The measurements include: deflections of the test spans, stresses in the segments near the mid-span and pier of the test spans, and concrete properties. The computed design values (theoretical results) of the deflections and stresses are also presented for comparison.

### Deflections

Deflections of the test spans, which are corrected for temperature variations, are shown in Figures 12 through 16.

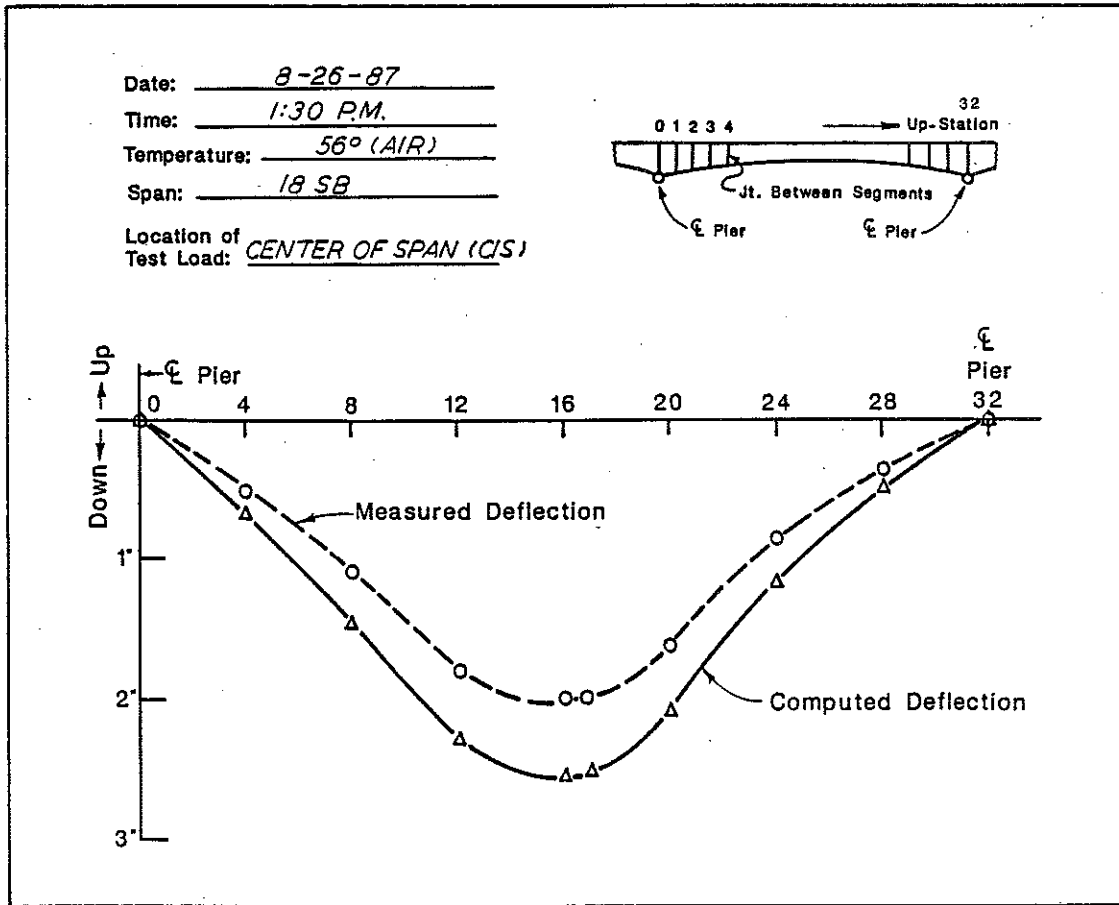

Figure 12. Deflections of Span 18S due to the Nooteboom.

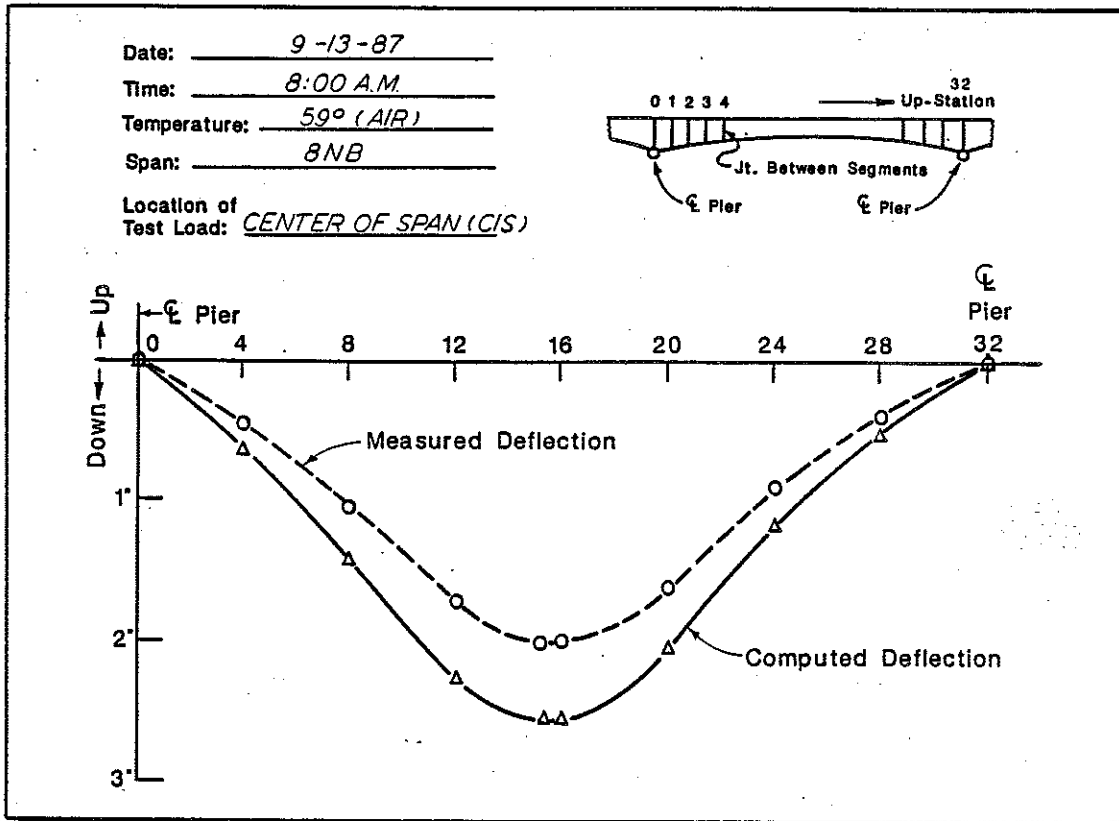

Figure 13. Deflections of Span 8N due to the Nootboom.

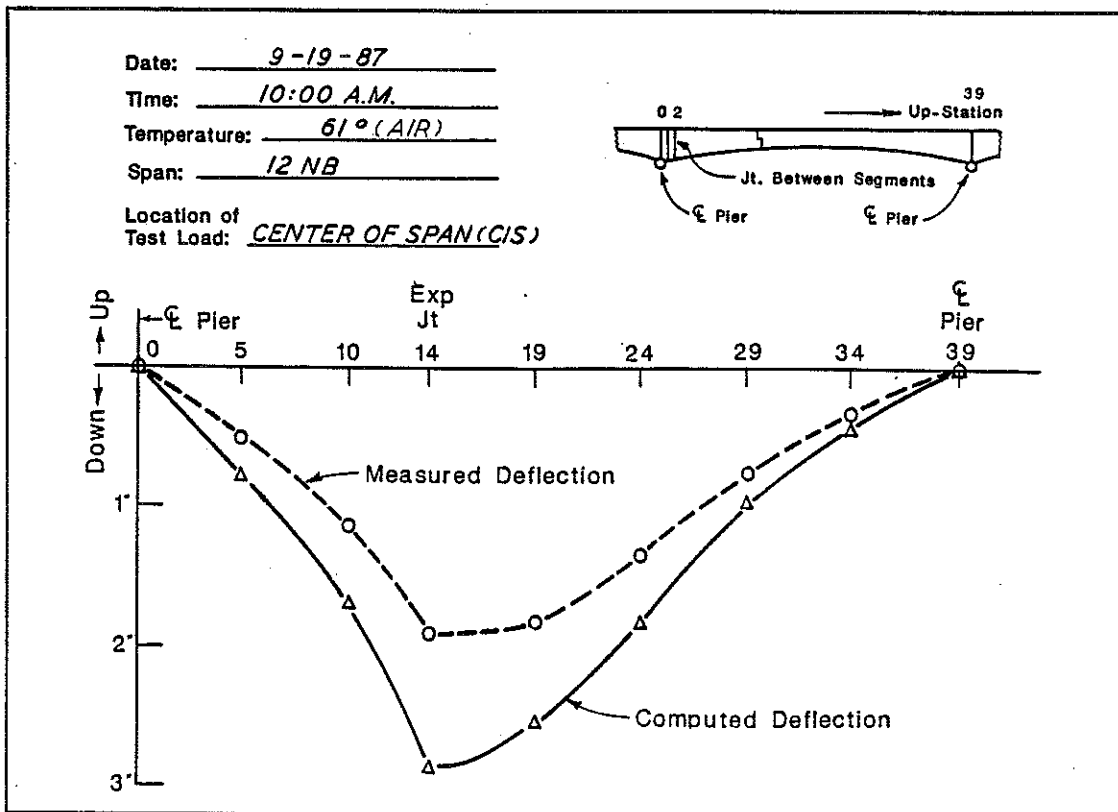

Figure 14. Deflections of Span 12N due to the Nootboom.

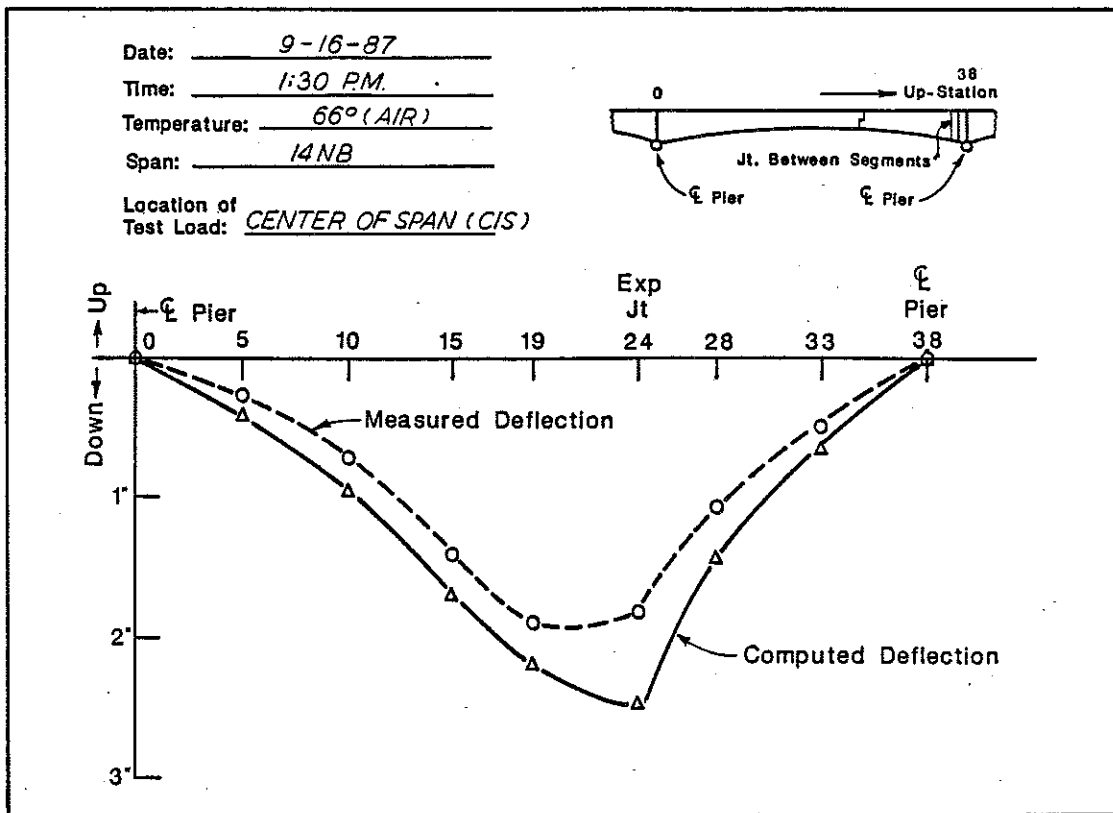

Figure 15. Deflections of Span 14N due to the Nootboom.

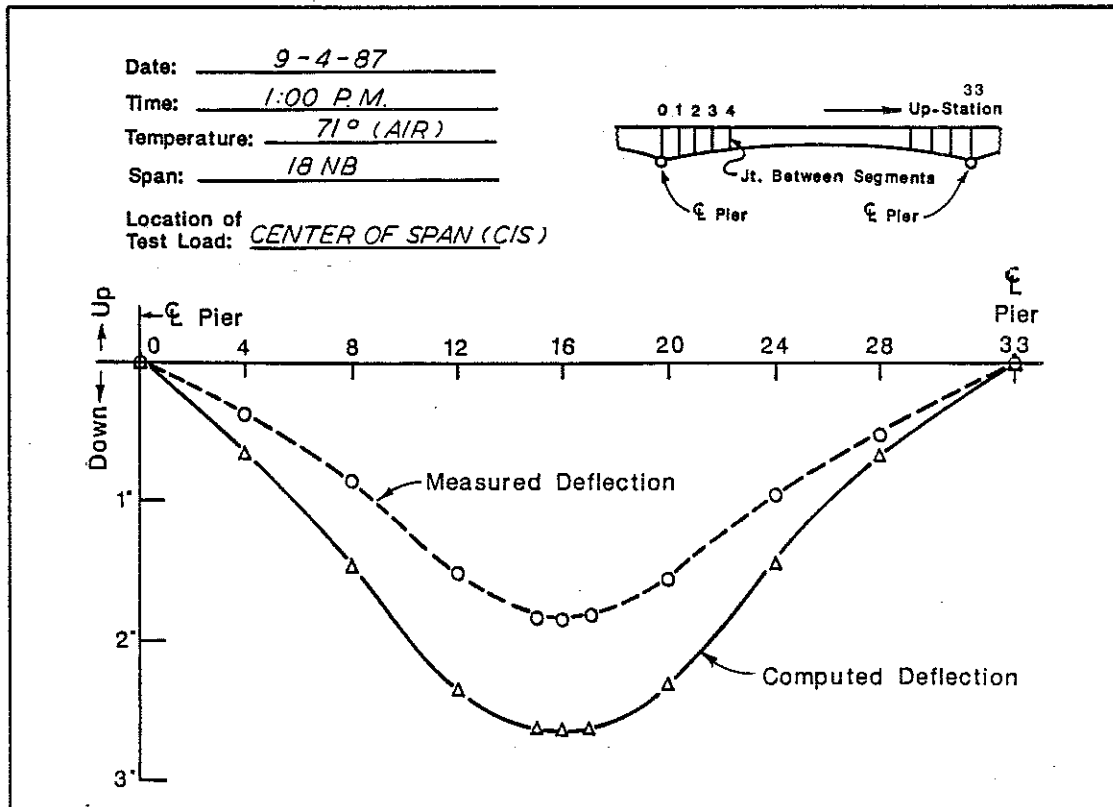

Figure 16. Deflections of Span 18N due to the Nootboom.

## Stresses

Stresses in the segments near the mid-span and pier of the test spans are shown in Figures 17 through 19. Figure 20 shows a graphic presentation of strain on Span 18 (southbound).

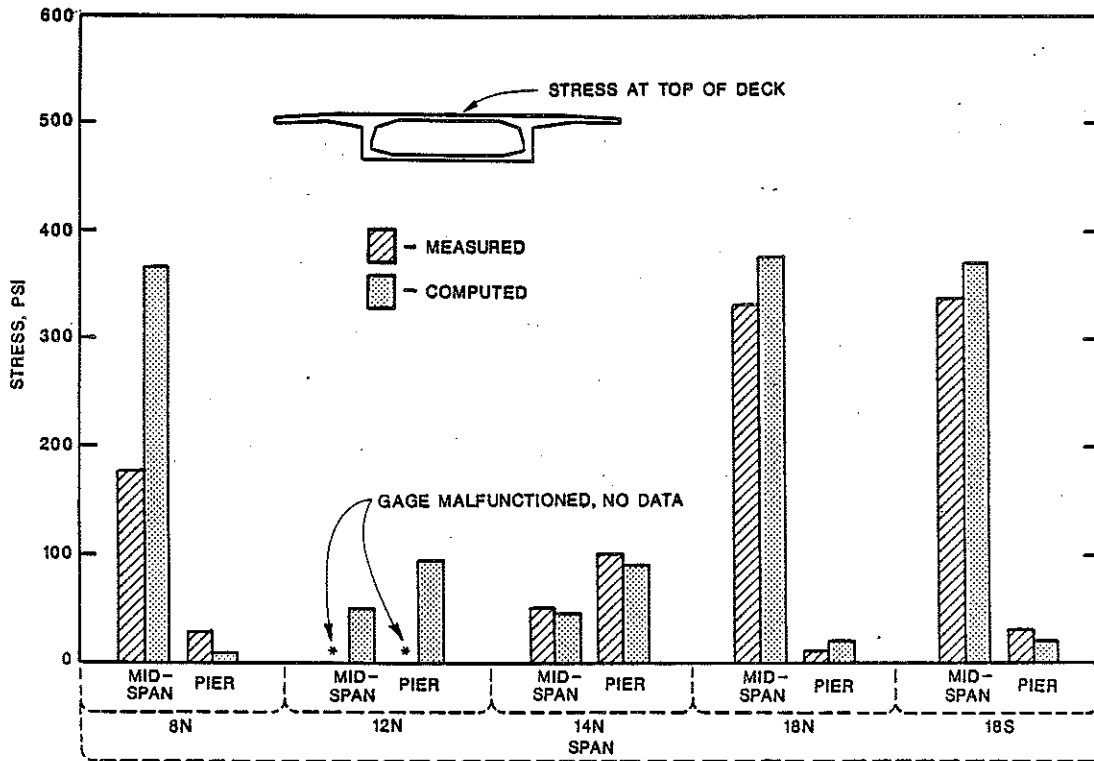

Figure 17. Comparison of stresses in segments with load at mid-span; stress at top of deck due to the Nooteboom.

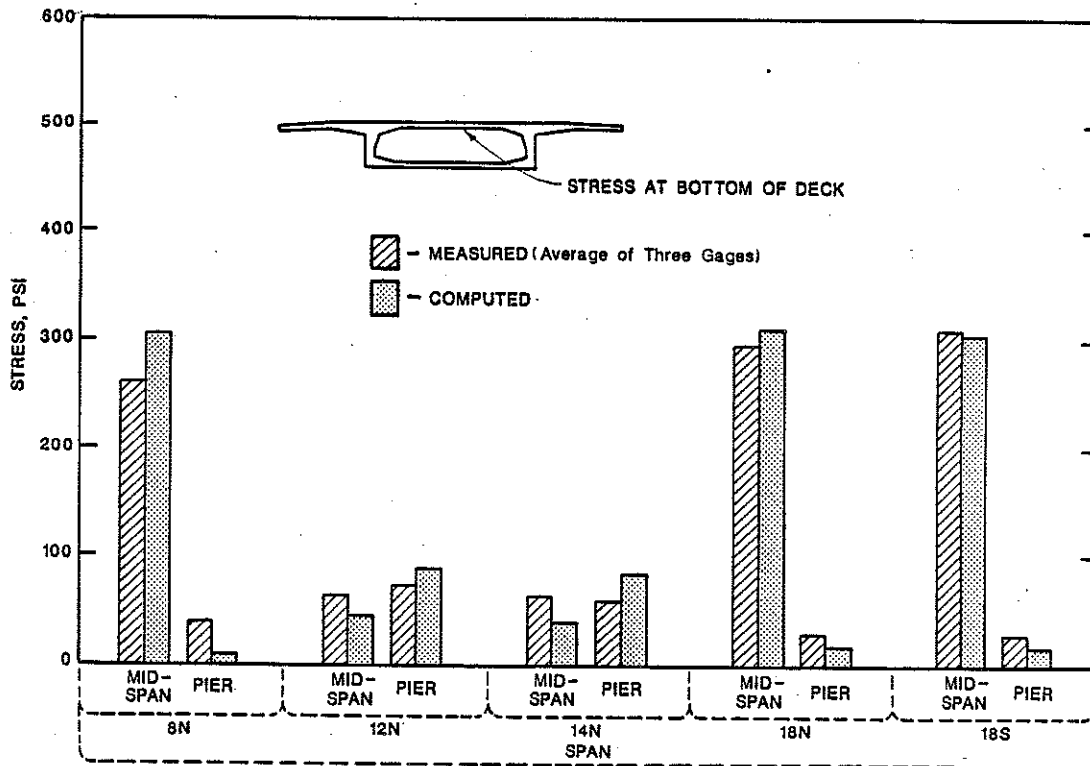

Figure 18. Comparison of stresses in segments with load at mid-span; stress at bottom of deck due to the Nootboom.

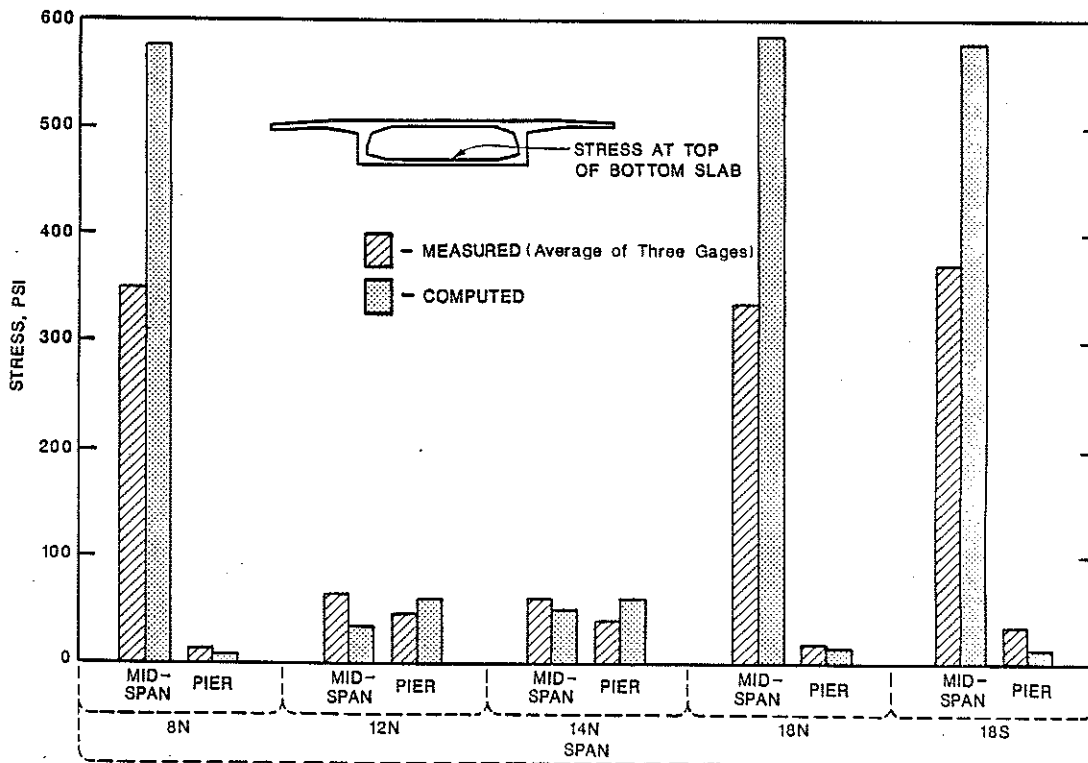

Figure 19. Comparison of stresses in segments with load at mid-span; stress at bottom of slab due to the Nootboom.

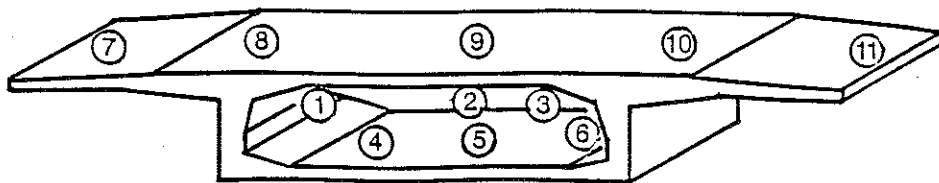
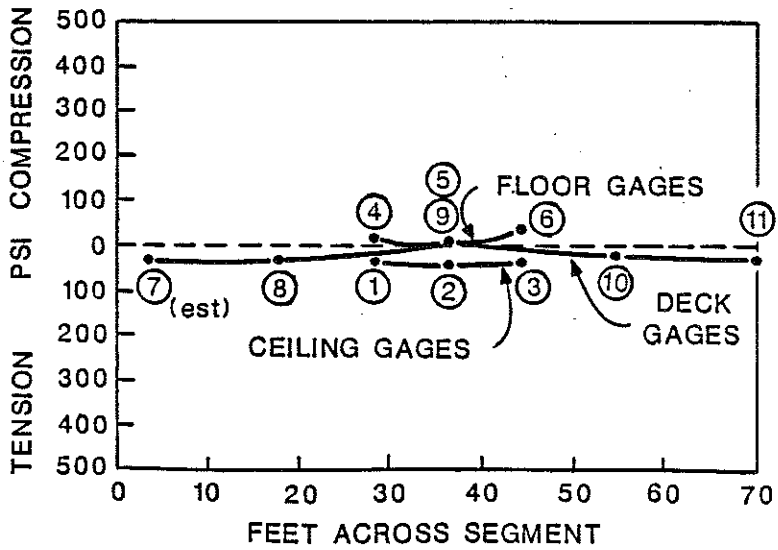
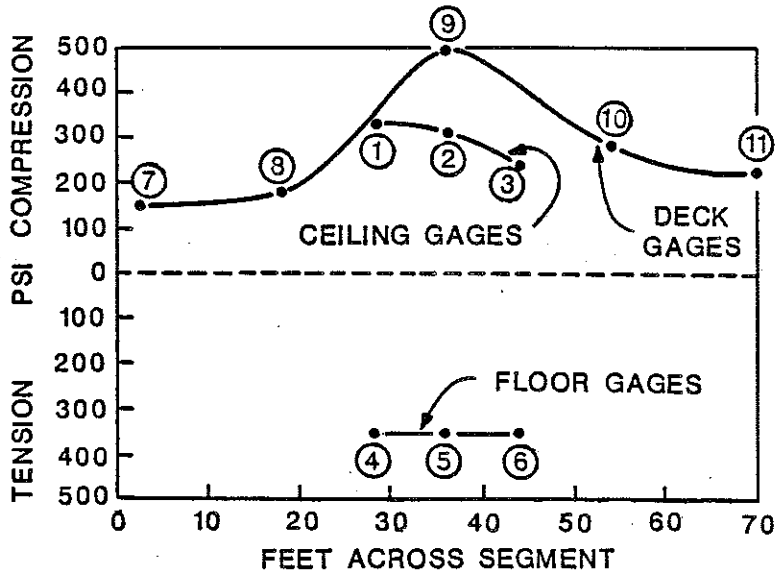

Figure 20. Graphic presentation of strain on Span 18S.

## Concrete Properties

Concrete properties were determined using core samples from the instrumented segments. Table 1 of the previous section gave the compressive strengths and modulus of elasticities of the core samples. Table 2 gives the average 28-day compressive strengths of the concrete cylinders from the test spans.

TABLE 2  
AVERAGE 28-DAY CONCRETE  
COMPRESSIVE STRENGTHS

Span	Average 28-Day Compressive Strength, psi
8N	6492 <sup>1</sup>
12N	7435
14N	7314
18N	7105
18S	6975
Average	7060 psi <sup>2</sup>

<sup>1</sup> Based on the tests of 3 concrete cylinders per segment. These are minimum 32 segments per span.

<sup>2</sup> Based on results of total 480 tests.

## Discussion of Results

Deflections - The measured deflections of the test spans were less than the computed deflections. At the mid-span the measured deflections (after correcting for temperature variations) were about 80 percent of the theoretical deflections (pages 17 through 19). The measured deflections were less due to the following:

- a) The design strength of concrete is 6000 psi. The actual concrete strength averaged 7800 psi at the time of the load test.
- b) On the northbound bridge, the latex modified concrete surfacing on the bridge is acting compositely with the concrete segments, thereby increasing bending stiffness.
- c) Similarly on the northbound bridge, the barrier railing is adding to the bending stiffness of the span.

The effects of concrete temperature variations on the deflections of the mid-spans due to the Nootboom were less than 3/32 of an inch.

The test spans rebounded completely after the Nootboom was moved off the span.

Stresses - The comparisons of measured and computed stress due to the Nootboom are presented in Figures 17 through 19 using bar charts. These indicate that:

- a) In general the measured stresses at the mid-span locations were less than the computed stresses.
- b) Near pier locations when the computed stresses were of small magnitude, i.e., less than 50 psi, the measured stresses were in reasonable agreement with computed stresses. Under field conditions the measurement of strains of such low level is very difficult, and may account for variations observed.
- c) The strain gages on the segment showed that the entire segment cross-section is acting to provide bending strength and stiffness.

Concrete Properties - Compressive strength ( $f_c'$ ) and modulus of elasticity ( $E_c$ ) of the concrete are presented in Table 1. Evaluation of the results indicate that the average compressive strength of concrete was 7800 psi, and the average value of  $E_c$  was  $4.9 \times 10^6$  psi.

In summary, the results of deflection and stresses were less than the analytical/design values and average concrete properties were higher than the analytical/design values.



## LONG-TERM BRIDGE MONITORING PROGRAM

### Regular Maintenance Inspections

MDOT has established a permanent Zilwaukee Bridge Maintenance Committee made up of engineers from the Design, Construction, Maintenance, and Materials and Technology Divisions, as well as District 6, Saginaw (Maintenance). This committee will be active in overseeing all inspection and maintenance activities on the bridge.

Inspections are planned on a biannual basis by a consulting firm knowledgeable in the design and maintenance of segmental concrete bridges. Inspections by MDOT engineers will take place on an annual basis.

### CMA Use and Latex Sampling

MDOT Bureau of Highways has decided to use CMA (calcium magnesium acetate) instead of calcium chloride as a deicing agent on the twin Zilwaukee bridges. Sodium chloride (NaCl), more commonly known as salt, is known to corrode steel, and since post-tensioned structures depend upon high strength steel cables for their structural integrity, the decision was made to use CMA, which is a non-corrosive salt substitute, for snow and ice control.

Salt use will stop at some distance (about one mile) away from the bridge. It is inevitable that some small amount of salt will be "tracked" onto the structures. In order to monitor the effect of this secondary salt, periodic samples of the latex concrete wearing surface will be taken and analyzed for salt content. If it is felt that an inappropriately high level of salt ions are present in the wearing surface, it can be replaced without disturbing the basic underlying structure.

### Elevation Monitoring

Post-tensioned concrete structures, such as the Zilwaukee Bridge, continue to deflect over their useful life. Most of this deflection takes place in the first few years after a structure is complete, and eventually reaches a point where changes in bridge profile are imperceptible (i.e., negligible).

As part of MDOT's Zilwaukee monitoring bridge program an "as built" profile of both bridges will be obtained when all latex concrete wearing surface and barriers have been completed. This will provide a baseline profile of the twin structures prior to placing them in service. Continued monitoring of the long-term deflections of the bridges is planned. Profile and responses of the bridges, determined in the subject experimental program, will be used as baseline information.

### Future Load Testing

As part of the current testing program, records have been made that measure the bridge response to a specific loading case. These responses, both

deflections and stresses, provide a benchmark of performance for this structure before being opened to traffic.

If, in the future, the bridge profile indicates more than expected changes, or if for any strongly justified engineering or administrative reason it is felt that the response of the bridge to loads should be re-established, it would be possible to repeat the same or equivalent testing that was completed in the summer of 1987. These new responses could be compared to the original values and judgements made as to any changes in condition of the structure.

## SUMMARY AND CONCLUSIONS

This report has presented the load testing program for the Zilwaukee pre-cast segmental concrete bridge. Five spans of southbound (18S) and northbound (8N, 12N, 14N, and 18N) roadways were selected for the testing. Span 12N was involved in the 1982 accident and span 8N was spalled during the winter of 85-86. The other three spans were typical comparable spans.

The Nooteboom truck and concrete bridge segment with a total weight of 258 tons were used as the test load. The test load was placed at mid-span. Field measured responses (deflections and strains) of the test span were compared to the calculated (analytical/design) values of these responses. This procedure was repeated for each of the five test spans.

Precision surveying instruments were used to measure deflections of the test spans. Strain gages and electronic instrumentation were used to measure strains in the concrete at the pier and mid-span locations. Core samples of the concrete of the instrumented segments were tested to determine compressive strength and modulus of elasticity of concrete. The analytical/design values of deflections and stresses in the test spans were obtained using a structural analysis computer program. Design values were provided by the consulting engineering firm of HNTB.

Based on the above load testing program, the following conclusions can be made:

- 1) The measured mid-span deflections due to the test load (Nooteboom) were about 20 percent less than the calculated (analytical/design) values. This indicated that the bridge performed better than the calculated values predicted.
- 2) The stresses determined from measured strains in concrete segments at the mid-span locations were less than the computed design values. Stresses in the concrete segments at the pier (support) locations were in reasonable agreement with the computed design values.
- 3) The entire cross-section of the segments acted to provide bending stiffness.
- 4) The design value of compressive strength of the concrete at 28-days was 6000 psi. The average 28-day compressive strength of concrete in the test spans was 7060 psi. The actual average compressive strength of concrete in the test spans at the time of the load test was 7800 psi. This indicates that concrete has gained considerable additional strength, since the 28-day tests were made. This increased strength of the concrete and associated increased stiffness have enhanced the performance of the test spans.

In summary, based on the load tests, the measured performance of the Zilwaukee Bridge was equal to, or superior to, the calculated performance.

A long-term bridge monitoring program is in the process of being implemented. The data gathered in the survey described in this report will serve as benchmark references for any further comparative measurements. Periodic condition surveys will be implemented.

## REFERENCES

1. "Structural Analysis Program (STRUDL)," Massachusetts Institute of Technology, Boston, MA.

"Static Load Tests of Two Detroit People Mover (DPM) Beams," CTL, Inc., Skokie, IL, 1986.

McClure, R. M., and West, H. H., "Full-Scale Testing of a Segmental Bridge," Proceedings of the National Bridge Conference, Pittsburgh, PA, pp. 212-223, 1983.

Kashima, S., and Breen, J. E., "Construction and Load Tests of a Segmental Precast Box Girder Bridge Model," Center for Highway Research, the University of Texas at Austin, 1975.

"Standard Specifications for Highway Bridges," American Society of State Highway and Transportation Officials, 1986.

"Standard Specifications for Transportation Materials and Method of Sampling and Testing," American Society of State Highway and Transportation Officials, 1986.

Zienkiewicz, O. C., "The Finite Element Method," McGraw-Hill, New York, 1971.

"Precast Segmental Box Girder Manual," Post-Tensioning Institute (PTI), Chicago, IL 1978.

## PART II

Part II of this report describes in detail the technical information about precision surveying, instrumentation, and concrete testing. Appendix B describes the sources of the equipment used.

### TECHNICAL INFORMATION

This section describes the precision surveying used to determine elevations of the test spans. The details of instrumentation used to measure strains in concrete segments of the test span are presented, followed by a brief description of methods used to test the concrete cores taken from the instrumented segments.

In testing the five spans, 60 strain gages were bonded to the interior of the bridge structure and 20 gages were bonded to the deck surface. Approximately 4000 ft of strain gage cable and 2500 ft of thermocouple wire were installed and subsequently removed for each span tested. About 80 man hours were required to instrument each test location. Equipment connections and recorder calibration required another 10 man hours.

#### Precision Surveying

The following equipment and procedures were used to determine elevations of the test spans during the load testing program:

##### Equipment Used:

- a) Zeiss Surveying Level with wedge reticle and parallel plate micrometer reading to 1/100 of the rod calibration
- b) Invar surveying rod set to read 1/2 cm  
(Combination reads to 1/200 cm (1/500 of an in.))
- c) Type T thermocouples recorded temperature readings

##### Procedure:

- a) Enter time started (to read against thermocouple tape)
- b) Enter weather conditions (e.g., sunny, wind 5-10 mph)
- c) Read Reference Point

All readings are done as follows:

- 1) Read left scale adjusting micrometer to read last two digits
- 2) Read right scale adjusting micrometer to read last two digits
- 3) Add 59250 to left reading and compare with right reading
- 4) If the comparison is not within 10 units repeat starting again with c(1)

- d) Read point of interest
- e) Take average of left and right readings and determine difference from Reference Point
- f) Convert distance to feet
- g) Depending upon the Reference Point used, the difference is added or subtracted from the Reference Point elevation to find the elevation of point of interest
- h) Example:

(c&d) Reference Point reading 91853; average of left and right reading is 94771

(e)  $91853 - 94771 = 2918$  difference (units are in 1/2 cm/100)

(f)  $0 - 2918/2$  (rod in 1/2 cm units) = -01459 (since units are now cm/100) = -14.59 cm

$-14.59 \text{ cm} / 100 \text{ cm/meter} = -.1459\text{M} = -0.479 \text{ ft}$   
 where  $1\text{M} = 3.2808 \text{ ft}$

(g) Elevation of point = Elevation of Ref. Pt. -0.479 ft

The form used for recording data was created by slightly modifying NOAA (National Oceanic and Atmospheric Administration ) Form 75-15 (below). A left rod reading is obtained and added to the factor of 59250. The right rod reading is taken and compared to the left total. The two readings must compare within 10 divisions to be considered an accurate reading, for example left reading of 08601, add to this 59250, equals 67851 and right reading of 67855.

NOAA FORM 75-15 (6-71)		U.S. DEPARTMENT OF COMMERCE NATIONAL OCEANIC AND ATMOSPHERIC ADMINISTRATION					FROM BM	TO BM			
SPIRIT LEVELING							WIND/SUN	TIME	DATE		
Point Number	ROD READING		Dif. from BM	Elev.		Point Number	ROD READING		Dif. from BM	Elev.	Live Load Dead Load Difference
	LEFT	RIGHT					LEFT	RIGHT			
	59250						59250				
	59250						59250				
	59250						59250				
	59250						59250				
	59250						59250				
	59250						59250				
	59250						59250				
	59250						59250				
	59250						59250				
	59250						59250				
	59250						59250				

## Bridge Instrumentation

In order to load test a bridge for its ability to carry predicted traffic loads and safety, it is necessary to apply a heavy load at the critical location in the structure and measure its deflection and strains. The Zilwaukee Bridge was tested by placing a loaded truck (258 tons) in the middle of a test span for approximately two hours. During this time the deflection of the span was measured as well as the movement of concrete (strain) in the segments at mid-span and at the pier. In addition, the truck was driven slowly at 3 mph across the test span four times in both directions to measure the dynamic strain in the concrete at the two critical locations which were at the mid-span and pier.

Strain is a measure of how much a material moves when it is compressed or when it is pulled (tension). Materials, such as steel and concrete, will return to their original shape if the force applied is not too large. These materials are said to be elastic. The relationship between the force applied to a material (lb/sq ft) and the amount of strain (in./in.) is  $\text{stress} = E_c \times \text{strain}$ , where  $E$  is referred to as the modulus of elasticity. The modulus of elasticity of concrete for each test span was determined by removing concrete cores from each instrumented segment.

Strain Measurement - Strain in bridge structural members is measured by bonding (firmly cementing) sensors to the concrete surface at locations where strains are the greatest. Each sensor, called a 'strain gage' consists of a continuous length of metal foil molded between thin insulating layers (Fig. 21). The gages used for testing the Zilwaukee Bridge were 4 in. long and about 1/2 in. wide. When bonded to concrete in accordance with the manufacturer's specifications, the gages will stretch or compress exactly the same as the concrete.

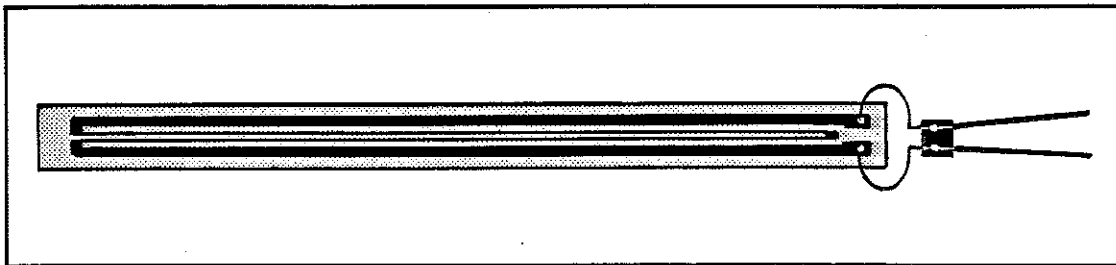

Figure 21. Strain gage (actual size).

The strain gage is connected to an electronic instrument called a strain gage conditioner and amplifier by a special shielded wire cable. When the gage stretches or compresses the electrical resistance of the gage wire foil increases or decreases respectively. This change in resistance can be measured through an electrical circuit called a "four-arm bridge." The four-arms of the bridge were completed at each strain-gage location by using precision resistors. This ensures that measured strains are not influenced by temperature changes in the long signal cables.



Electrical signals from this equipment are subsequently connected to chart recorders which display the change in bridge segment movement (strain) (Fig. 22).

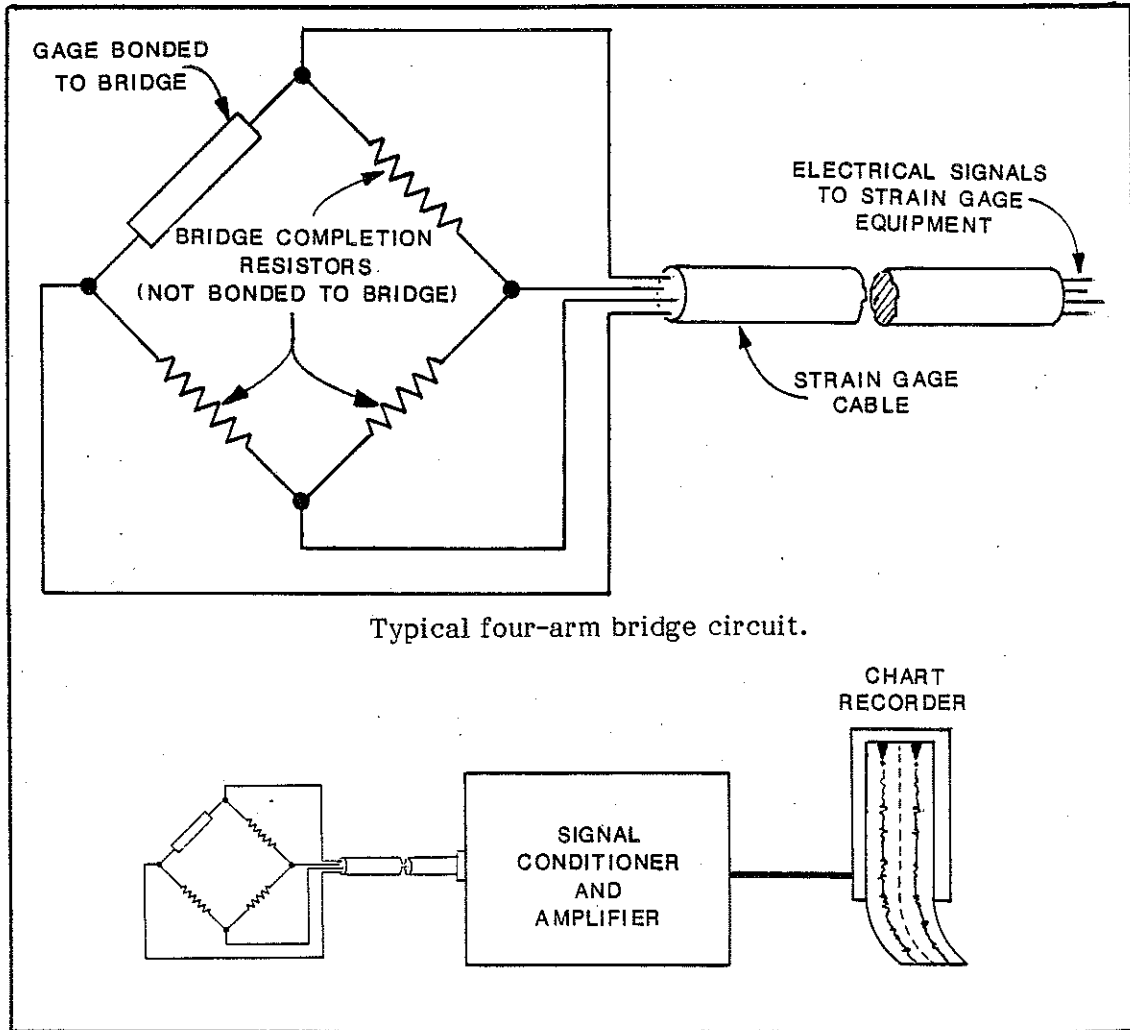

Figure 22. Electronic set-up used to obtain a permanent record of bridge strain at each measurement location.

Strain gages were installed inside the bridge structure at twelve locations for each span tested. Three gages were attached to the ceiling and three to the floor at the mid-span segment and similarly at one pier segment. Gages were also installed on the bridge deck top surface at mid-span and pier as shown in Figure 23.

The electronic instrumentation equipment and chart recorders were located in a van positioned on the bridge deck near the span being tested. Strain gage

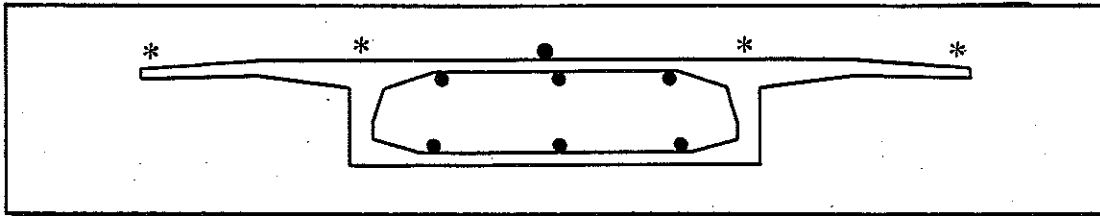

Figure 23. Location of strain gage sensors at mid-span and pier segments. Deck gage locations (\*) varied on spans tested; this configuration used on Span 18S.

cables from the instruments were routed through the expansion joint to the strain gages located about 150 feet away. Cables for the deck sensors were laid on the top surface and protected by boards placed transversely across the deck. Deck gages were protected by a 6-in. length of steel channel fastened over the gage.

Temperature Measurement - Temperature measurements were also obtained at several locations on the bridge structure. Temperature instrumentation consisted of installing Type T thermocouple wire between each measurement location and the instrument van.

The thermocouple wire is manufactured with two conductors. One conductor is copper and the other constantan. When these conductors are twisted together, a small electrical voltage is produced. The amount of voltage is proportional to the temperature of wire where the conductors are in contact. The thermocouple wire from each measurement location was attached to a temperature recorder. Sensor locations are shown in Figure 24. Temperatures were recorded every half hour for a period of 24 hours before the span was tested to six hours after the test was completed.

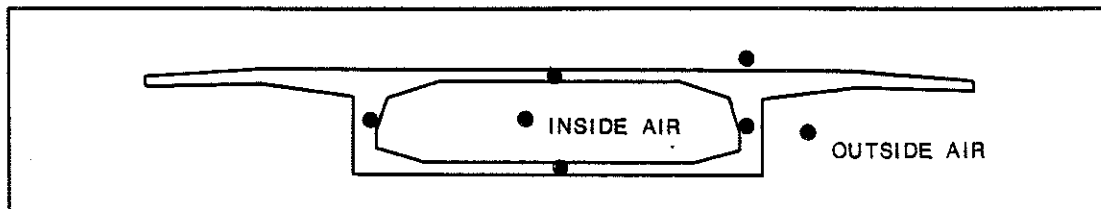

Figure 24. Location of temperature measurements at pier and mid-span segments.

#### Strain Measurement Procedure

Following is a description of the procedure used to measure strain in the bridge segments while the test load was placed at the mid-span of a test span.

Prior to the testing of each span, strain gages and thermocouple temperature sensors were installed as described in "Bridge Instrumentation." This work required approximately 64 man hours per span to complete.

Approximately one hour before the test was to begin, the equipment was turned on and allowed to reach operating temperature. Each four-arm bridge at each sensor location was balanced and the amplifier gain adjusted to the correct value. After adjustment, each bridge circuit was offset using a calibration resistor which simulates a known value of strain. The resultant offset voltage was recorded on the appropriate chart recorder. After calibration, each signal channel was returned to the normal balanced condition.

After all equipment was properly adjusted and calibrated the load vehicle was allowed to travel on the bridge and move to the center of the span being tested. The vehicle was stopped with its center of load over the center of the span. Strain measurements from all sensors were recorded while span deflection measurements were made. Subsequently, the truck was slowly guided across the span and continued across the bridge until it was several spans away and all sensors returned to a balanced condition.

The tractor was then disconnected from the load and repositioned at the opposite end for the pull back across the span. This process was repeated until the load vehicle had made a minimum of three additional passes over the span being tested. This process required approximately two hours to complete.

After completion of the dynamic testing (test load traveling at 3 mph), the load vehicle was again stopped at the center of the span and additional deflection measurements were obtained. After this final measurement, the truck moved off the bridge. Strain sensors were monitored to determine if they all returned to a zero no-load condition. This process was repeated for each span tested.

Calibration Procedure for Strain Measurements - The following procedure was used to calibrate the strain measurement equipment.

All strain gages used on the project were purchased from the same company. All gages were produced from the same production run and, therefore, are as identical to each other as is possible with current technology. Therefore, the physical and electrical properties of each gage are virtually identical. Figure 21 shows the type of gage used for calibration and measurement on the Zilwaukee Bridge.

Two strain gages were positioned longitudinally on opposite sides of a 6-in. diameter by 12-in. long concrete cylinder and bonded in accordance with the manufacturer's specifications. The cylinder was obtained from concrete used in the construction of the bridge segments.

Each gage was then connected into a four-arm bridge electrical circuit as previously described. The core was then placed in a load frame. A known load or force was applied to the core in increments of 1,000 to 28,000 lb. The resulting strain was recorded on a chart recorder. Subsequently, the modulus of elasticity of this cylinder was measured and found to be  $4.7 \times 10$  .

Care was taken to ensure that the same strain was measured from each gage as the load was applied. The recorded chart data provided the relationship between the force applied in pounds per square inch (psi) and the electrical voltage produced by the strain gage equipment.

Each time a span was to be tested this same value of voltage was recorded on each chart recorder using a calibration resistor. This procedure is the most accurate method of calibration and electrical circuits are provided in strain gage equipment to easily perform this function.

Subsequent to this procedure, the modulus of elasticity of the concrete core was determined. Cores taken from each segment instrumented were also tested to determine the modulus of elasticity ( $E_c$ ).

Accuracy of Strain Measurements - The accuracy of strain measurements is a function of calibration procedure and instrument precision. Full scale calibration was based upon expected strain values in bridge segments. The concrete cylinder used for calibration was loaded to 1500 psi. This results in a deflection of 50 mm on the chart recorder or 30 psi/mm. It is possible to visually interpolate the strain within one-half of the smallest division which results in a resolution of 15 psi.

Instrument accuracy is stated to be 0.1 percent by the manufacturer. This results in a precision of  $\pm 1.5$  psi. Therefore, the resultant precision of the strain measurement system is 18 psi.

#### Concrete Coring and Testing

Concrete cores, one per instrumented segment, were removed. The M&T Laboratory tested the cores to determine compressive strength and modulus of elasticity using ASTM C-42 and C-469 test procedures, respectively.

APPENDIX A  
Nooteboom Weighing Report

STATE OF MICHIGAN



JAMES J. BLANCHARD, GOVERNOR  
DEPARTMENT OF STATE POLICE

COL. R. T. DAVIS, DIRECTOR

Sept. 3, 1987

Mr. Bard Lower  
Assistant Supervising Engineer  
Structural Research Unit  
Michigan Department of Transportation  
Lansing, MI 48909

Dear Mr. Lower;

I trust the attached report will meet your needs as to the weights Nooteboom and segment for your tests of the Zilwaukee Bridge. My three Probationary Officers and I enjoyed the experience and the tour of the bridge.

I am looking forward to seeing the completion of that project and I anticipate being in one of the first vehicles to cross.

Sincerely,

A handwritten signature in cursive script that reads "Bill Story".

Lt. Bill Story  
Third District Supervisor  
Motor Carrier Division

**ORIGINAL  
INCIDENT REPORT**

ORIGINAL DATE 8/26/87	INCIDENT NO. 37-4642-87
TIME RECEIVED	FILE CLASS 9900-8
WORK UNIT Post 37 - Bridgeport	COUNTY Saginaw

COMPLAINANT Bard LOWER - Mich. Dept. of Transportation		TELEPHONE NO.	
ADDRESS: STREET & NO.	CITY	STATE	ZIP CODE

INCIDENT STATUS

<input checked="" type="checkbox"/> 5	0 OPEN	1 LEIN VALIDATION	2 UNFOUNDED	3 EXCEPTIONAL CLEARANCE
	4 INACTIVE	5 CLOSED	6 OPEN PENDING RELEASE OF PROPERTY	7 TOT OTHER POLICE DEPT.

NATURE OF INCIDENT Assist Dept. Of Transportation/Weigh Test Vehicle

INFORMATION:

Our Division was contacted by the Dept. of Transportation, with a request to weigh a vehicle. For test purposes, they wanted to know the weight of a vehicle combination being used in the construction of the new Zilwaukee Bridge. Lt. STORY, Officers ZARA, TURNER, and I went to the construction site and weighed the vehicles using portable scales.

TIME-DATE-VENUE:

The detail began at 9:00am, and finished at 1:00pm, on Wednesday, 8/26/87, at the new bridge construction site, Zilwaukee Twp, Saginaw County.

VEHICLES AND CONFIGURATION:

The combination consisted of a three axle power unit and a six axle full trailer. The power unit had a single steer axle, with two tires, and two drive axles with four tires on each axle. The trailer's six axles were in two groups of three axles each, and each axle had four tires. Each tire was weighed individually.

WEIGHTS:

Axle	Left	Tire Weights From to		Right	Total for this Axle
1		9,650		9,800	19,450
2	7,100	9,500	10,000	8,200	34,800
3	7,000	9,200	12,000	6,550	34,750
*****					
4	16,000	16,850	17,400	18,900	69,150
5	17,800	17,600	18,000	17,400	70,800
6	18,500	19,600	18,150	19,100	75,350
7	16,300	18,600	17,000	17,400	69,300
8	17,050	16,950	18,300	18,100	70,400
9	18,000	19,900	17,950	17,500	73,350

(TOTAL GROSS WEIGHT: 517,350 lbs)

STATUS:

Closed.

INVESTIGATED BY Lt. W. STORY & Ofc's ZARA, TURNER, JURKOWSKI	REPORTED BY <i>[Signature]</i> Ofc V. Jurkowski	REVIEWED BY
--	---	-------------

Incident No. 37-4642-87

File Class 9900-8

## APPENDIX B

### Measuring Equipment

#### Description of instruments for strain and temperature measurements:

Strain Gage:	Measurements Group, Inc. Raleigh, North Carolina Catalog No. EA-06-40 CYB-120 Gage length 4 inches
Strain Gage Equipment:	Measurements Group, Inc. Multichannel gage conditioner and amplifier system with power supply and digital read-out Model #2100
Chart Recorders:	Gould/Brush, Inc. Instruments Division Cleveland, Ohio 2 channel high performance direct writing recorder Model #2200
Temperature Recorder:	Kaye Instruments, Inc. Bedford, Massachusetts 16 channel Digistrip II

#### Precision surveying instruments:

Level:	Ziess Model Ni12 Automatic with Micrometer
Rod:	Of Invar material, metric