

3/16" Dia. holes in angle for 6 adhesive anchor 3/4" dia. stainless steel bolts spa @ 7 1/2" (Typ.)

**DETAIL OF CONNECTION**

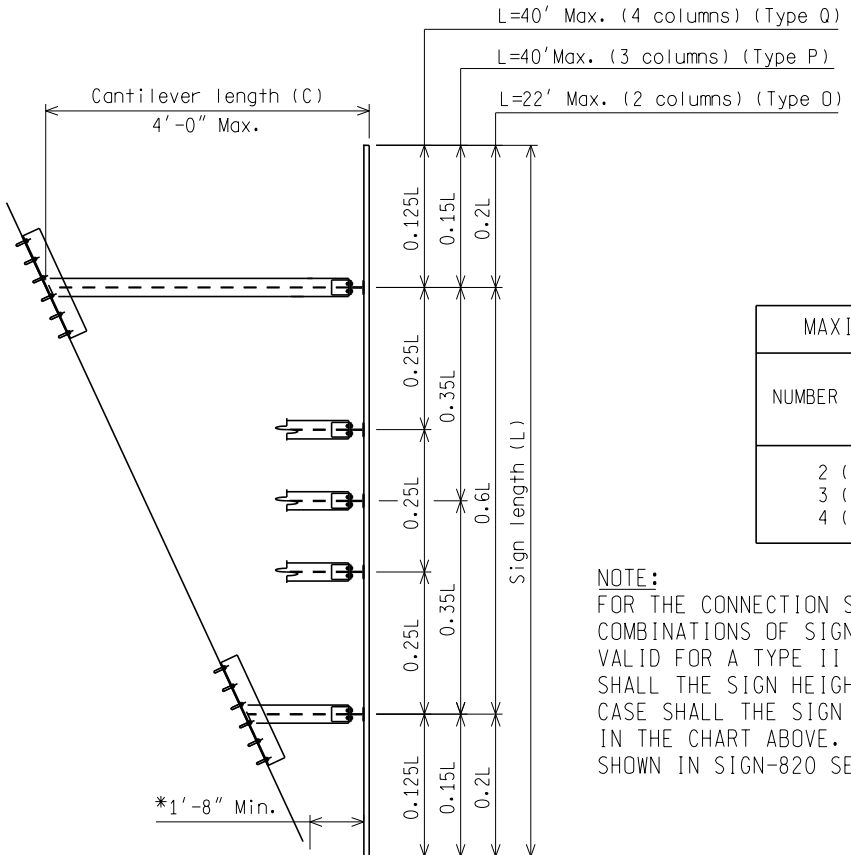

MAXIMUM SIGN AREA	
NUMBER OF COLUMNS	SIGN AREA (SFT)
2 (TYPE Q)	200
3 (TYPE P)	300
4 (TYPE Q)	380

**NOTE:**  
 FOR THE CONNECTION SHOWN IN THIS TYPICAL, ALL COMBINATIONS OF SIGN HEIGHT AND SIGN LENGTH ARE VALID FOR A TYPE II COLUMN. IN NO CASE, HOWEVER, SHALL THE SIGN HEIGHT EXCEED 10 FEET AND IN NO CASE SHALL THE SIGN AREA EXCEED THE VALUES GIVEN IN THE CHART ABOVE. THE COLUMN SELECTION CHART SHOWN IN SIGN-820 SERIES SHALL BE IGNORED.

NOT TO SCALE

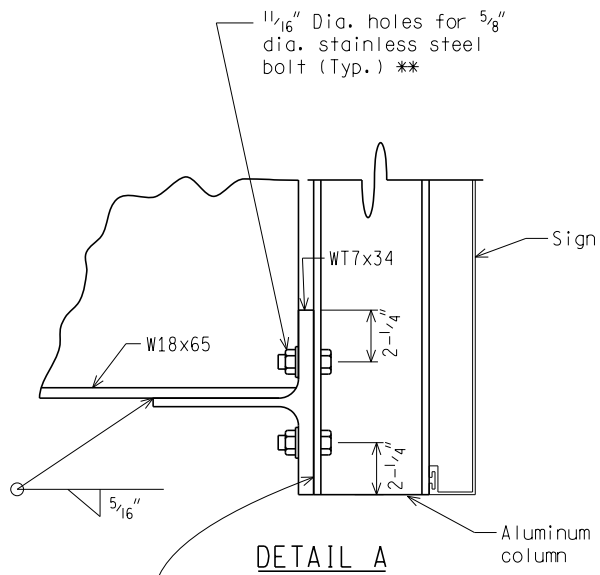

Place 1/8" elastomeric (or equivalent) pad to cover entire surface area between steel and aluminum sections.

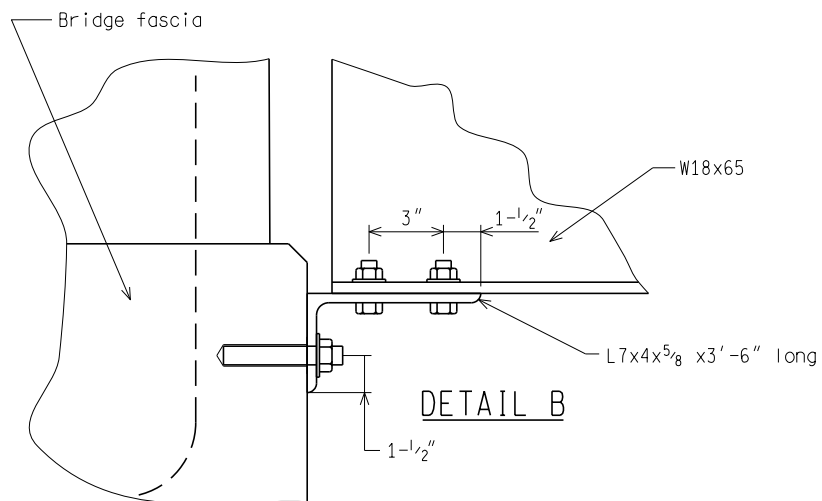

NOT TO SCALE

MICHIGAN DEPARTMENT OF TRANSPORTATION

(SPECIAL DETAIL)  
F.H.W.A. APPROVAL

02/27/26  
PLAN DATE

SIGN-870-C

SHEET  
3 OF 5

**NOTES:**

1. Field verify bridge dimensions prior to fabrication.
2. Welding shall be in accordance with the Standard Specifications for Construction.
3. All structural steel members shall be hot-dip galvanized in accordance with the Standard Specifications for Construction.
4. All aluminum members shall be ASTM B 308 Aluminum Alloy 6061-T6 and shall conform to ASTM B 221.
5. Structural steel members shall conform to AASHTO to M 270 Grade 36 or Grade 50S.
6. All high-strength bolts, nuts and washers shall be in accordance with Subsection 906.07 and installed according to Subsection 707.03.E.6 of the Standard Specifications for Construction except for stainless steel bolts, nuts and washers.
7. Stainless steel bolts and washers shall conform to ASTM A 320, Class 1, Grade B8. Nuts shall be self-locking nylon insert type and must conform to ASTM A 320, Grade 8F. Stainless steel nuts and washers shall always accompany stainless steel bolts. Stainless steel bolts, nuts and washers shall be used at connections with aluminum members. All other connections shall utilize galvanized high strength bolts, nuts and washers unless otherwise specified.
8.  $\theta$  = Angle between sign and bridge fascia. Angle is a function of permissible cantilever length (C) and sign length.
9. All concrete anchors shall be chosen from the qualified product list in the MDOT Materials Source Guide. All concrete anchors shall be installed according to the manufacturers recommendations and subject to the requirements of Section 712.03.J of the Standard Specifications. Field testing up to 90 percent of the bolts yield strength is waived. Extreme caution shall be exercised when drilling holes for concrete anchors. Existing bridge plans shall be reviewed to determine reinforcing steel locations and to evaluate the risk of damaging reinforcement associated with installing concrete anchors.
10. The bottom edge of the sign shall be horizontal when erected.
11. If replacing an existing sign support, existing holes in concrete shall not be reused and shall be filled with a non-shrink grout in accordance with section 1005.02.B of the Standard Specifications for Construction.
12. Inspection of proposed locations shall be performed to determine viability of connection to existing bridge.
13. See Subsection 810.03.P of the Standard Specifications for bolt replacement in retained bridge mounted sign connections.
14. Removal of existing bridge sign connections shall be according to Subsection 810.03.U of the Standard Specifications.
15. See Section 810 of the Standard Specifications for bridge sign connections to existing bridges.
16. The design of this sign connection is based on the assumption that the concrete has a Minimum Compressive Strength of 4000 psi. If it is suspected that the concrete is of lesser strength or is in poor condition, this sign connection shall not be used.
17. See Sign-810 Series and Sign-820 Series for other details.
18. Surface rustication (texturing) at connections to railing shall be eliminated behind signs.
19. Sign panel connections to aluminum columns shall have the same bolt arrangement as shown for sign panel connections to aluminum columns for cantilever and trusses (see typical plan Sign-700 Series).

NOT TO SCALE

MICHIGAN DEPARTMENT OF TRANSPORTATION

(SPECIAL DETAIL)  
F.H.W.A. APPROVAL

02/27/26  
PLAN DATE

SIGN-870-C

SHEET  
4 OF 5

NOTES (CONTINUED):

- 20. All members are steel except aluminum columns.
- 21. The design of this bridge sign connection is according to the AASHTO LRFD Specifications for Structural Supports for Highway Signs, Luminaires and Traffic Signals, 1st Edition, with interim revisions through 2022. The design is also based on the assumption that the barrier reinforcement is embedded in the fascia beam.
- 22. This typical shall only be used with new bridge railing of the following types: Bridge Barrier Railing, Type 4; Bridge Barrier Railing, Type 5; Bridge Barrier Railing, Type 6; Bridge Barrier Railing, Type 7; or Bridge Railing, Aesthetic Parapet Tube.
- 23. This typical is to be used only for MI-1800 and Wisconsin beam bridges.

NOT TO SCALE

MICHIGAN DEPARTMENT OF TRANSPORTATION	(SPECIAL DETAIL ) F.H.W.A. APPROVAL	02/27/26 PLAN DATE	SIGN-870-C	SHEET 5 OF 5
---------------------------------------	--	-----------------------	------------	-----------------