

LEFT TURN STORAGE LANE(S) MARKING DETAILS

FOR STOP CONTROLLED OR SIGNALIZED INTERSECTIONS

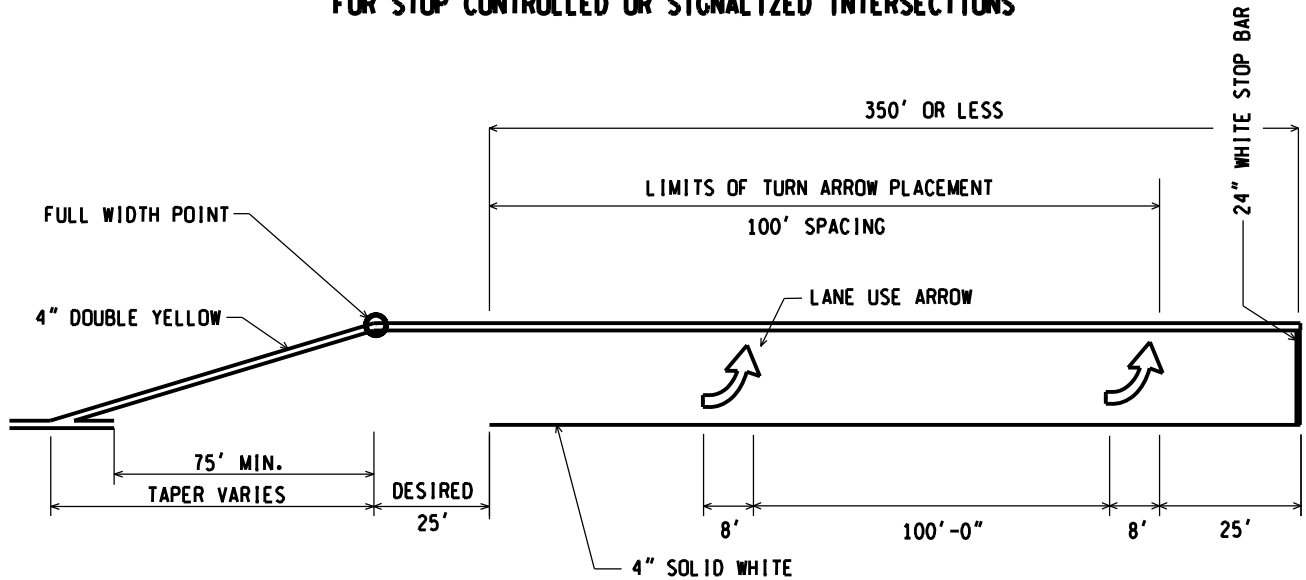

LEFT TURN ARROW PLACEMENT FOR STORAGE LENGTHS 350 FT OR LESS

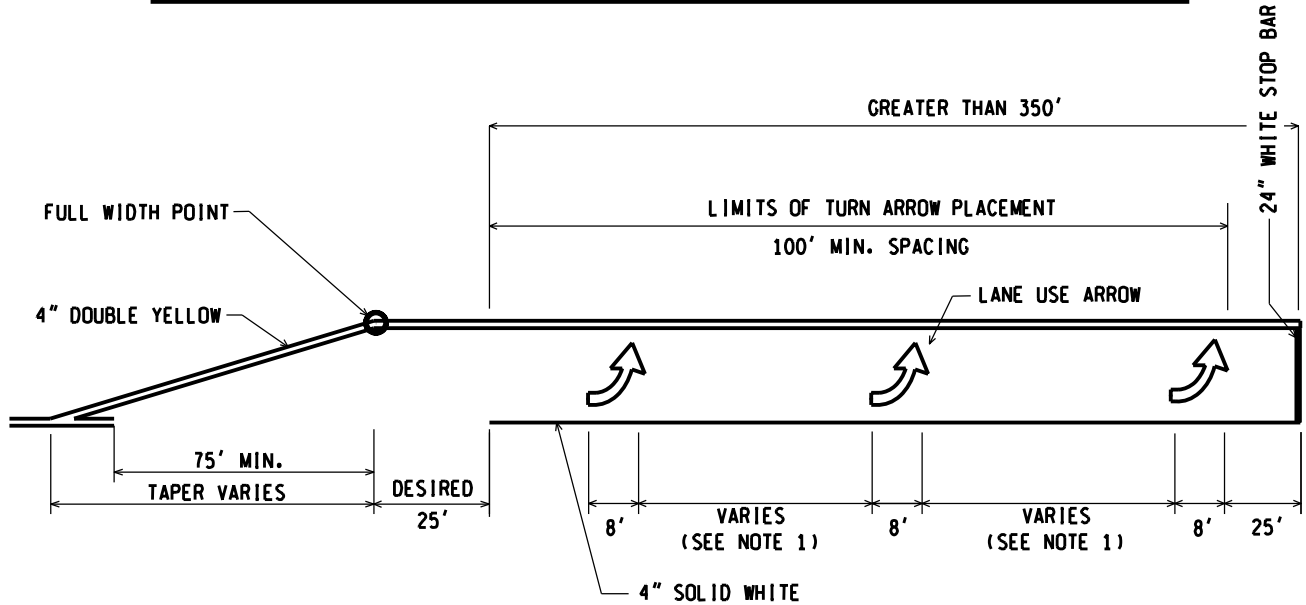

LEFT TURN ARROW PLACEMENT FOR STORAGE LENGTHS GREATER THAN 350 FT

NOTES:

1. Where the storage length is greater than 350 ft, use a minimum of three arrows. Place additional arrows as directed by the Engineer. Arrows should be evenly spaced throughout the available length with a minimum spacing of 100 ft.
2. Arrows shall be used in exclusive turn lanes at signalized intersections. When used, they shall be located as shown.
3. A 4 inch yellow left turn edge line may be used adjacent to raised curbs or medians in a left turn lane.

 PREPARED BY TSMO DIVISION DRAWN BY: <u>MKB</u> CHECKED BY: <u>CMW</u>	DEPARTMENT DIRECTOR Paul C. Ajegba Gregg Brunner, P.E. Gregg Brunner Nov 2 2020 12:09 PM APPROVED BY: _____ DIRECTOR, BUREAU OF FIELD SERVICES	MICHIGAN DEPARTMENT OF TRANSPORTATION BUREAU OF DEVELOPMENT STANDARD PLAN FOR <h2 style="margin: 0;">LEFT TURN LANE MARKINGS</h2>		
	Bradley C. Wiefelrich Bradley C. Wiefelrich Nov 5 2020 5:49 AM APPROVED BY: _____ DIRECTOR, BUREAU OF DEVELOPMENT	09/21/20 F.H.W.A. APPROVAL	03/25/20 PLAN DATE	PAVE-935-E

DOUBLE LEFT TURN STORAGE LANES MARKING DETAILS

FOR STOP CONTROLLED OR SIGNALIZED INTERSECTIONS

FOR "D" VALUES SEE
PAVE-900 SHEET 8

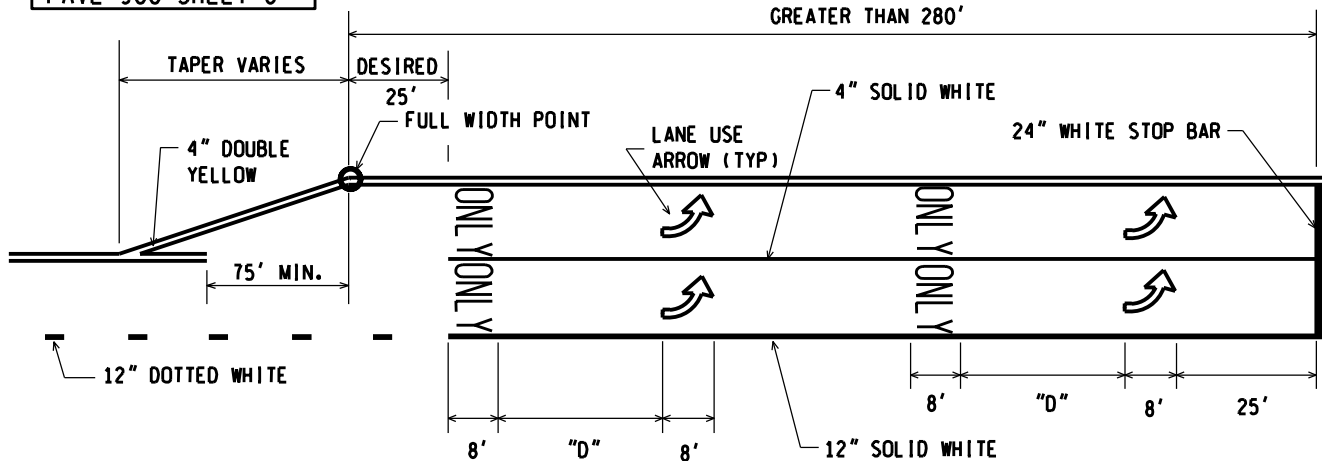

THROUGH LANE BECOMES EXCLUSIVE LEFT TURN LANE

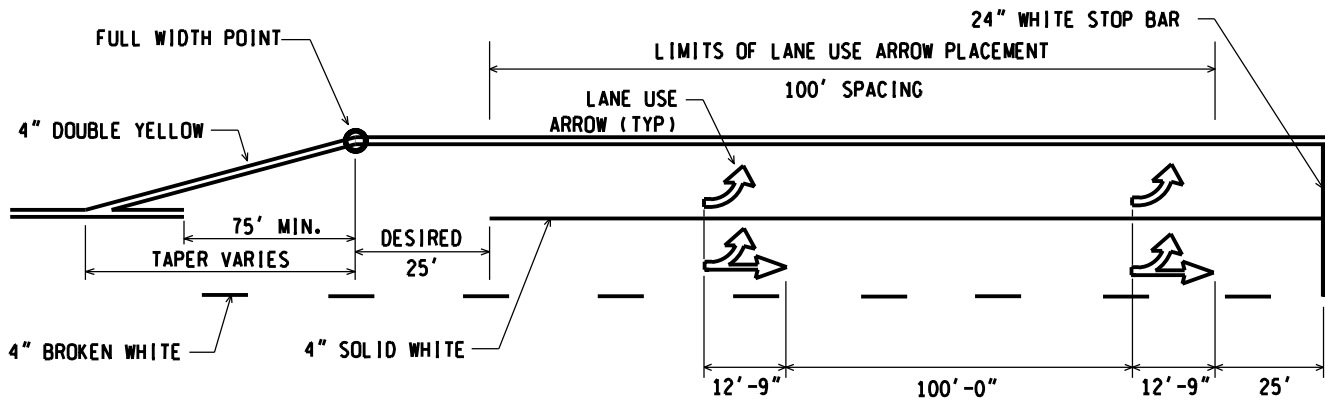

THROUGH LANE BECOMES OPTIONAL LEFT TURN LANE

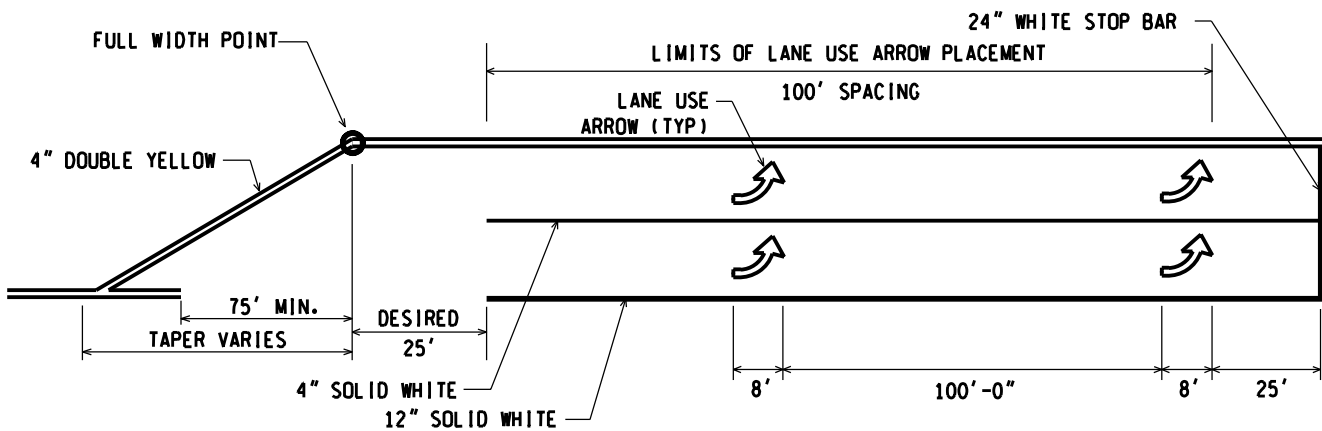

DUAL DEVELOPED LEFT TURN LANES

NOTES:

1. Where at least one through lane becomes an exclusive turn lane, arrow and legend markings shall be used. Otherwise, omit the legend markings.
2. For double left turn lanes 280 ft or less, omit the second set of arrow-legend pairs and/or combination arrows in each lane.
3. When two or more arrow/legend sets are used and spacing between sets is less than "D", the Engineer may choose to reduce the distance between the arrow and legend.
4. Include a dotted turning guideline for all double turn movements.

NOT TO SCALE

MICHIGAN DEPARTMENT OF TRANSPORTATION
BUREAU OF DEVELOPMENT STANDARD PLAN

09/21/20
F.H.W.A. APPROVAL

03/25/20
PLAN DATE

PAVE-935-E

SHEET
2 OF 6

LIMITED LENGTH LEFT TURN LANES FOR SIGNALIZED INTERSECTIONS

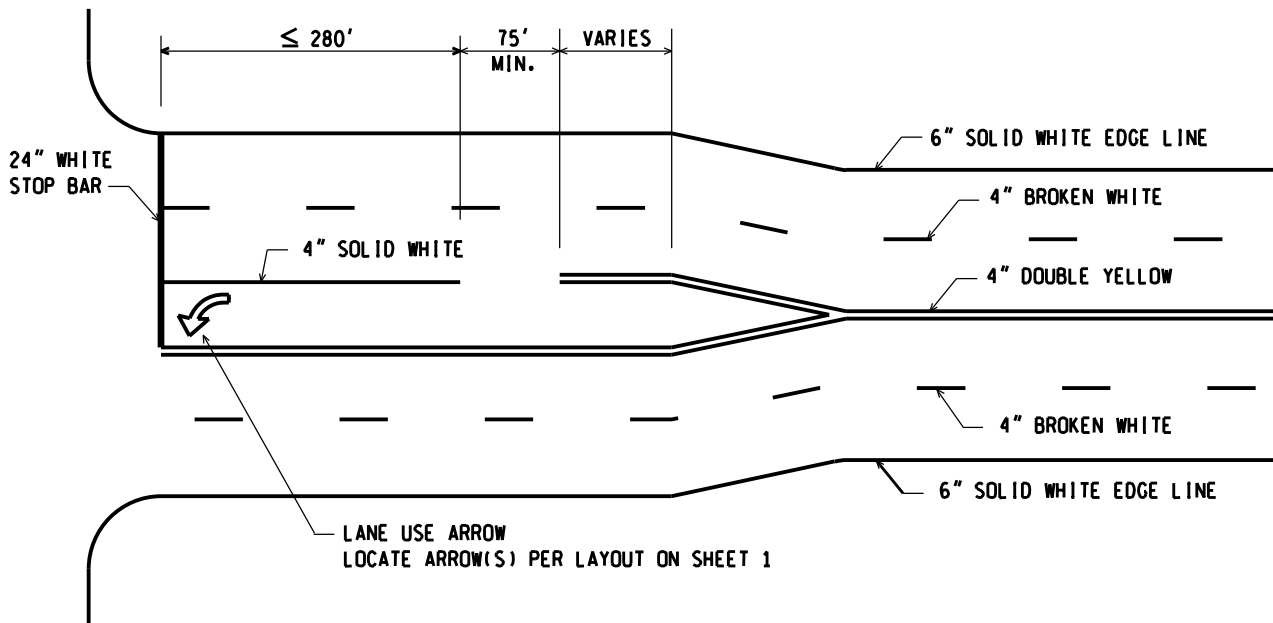

355 FT OR LESS OF FULL WIDTH CENTER LANE FOR LEFT TURNS

* REMAINDER OF 5 LANE SECTION TO BE MARKED AS A BI-DIRECTIONAL LEFT TURN LANE (SEE SHEET 5)

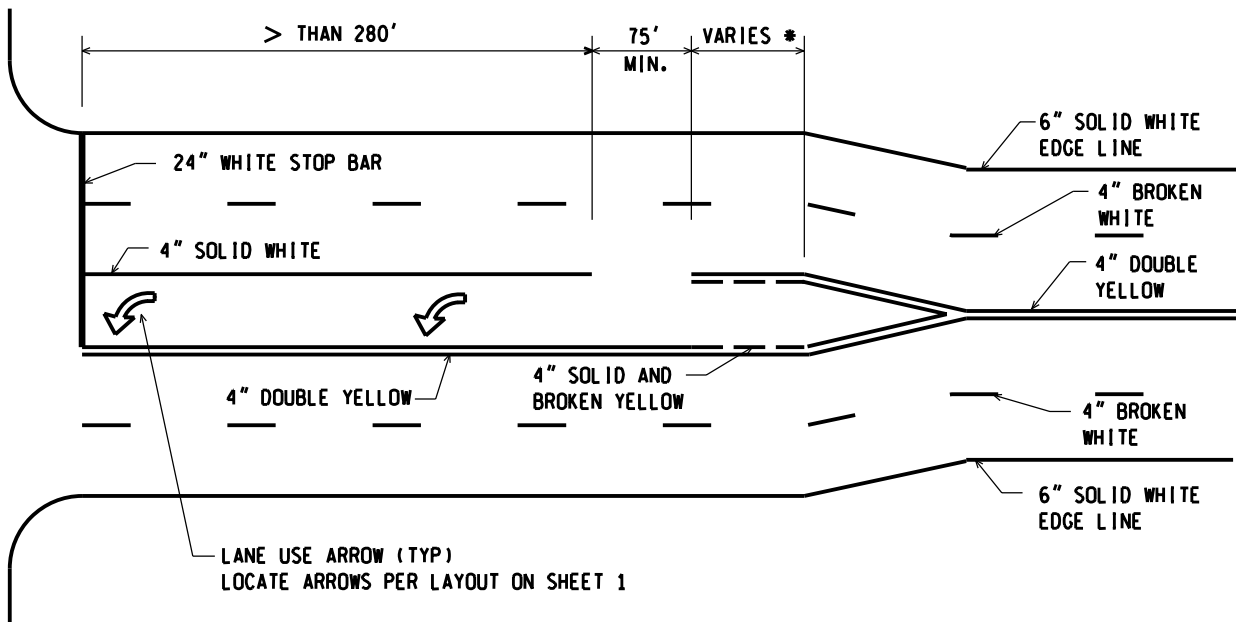

FOR FULL WIDTH CENTER LEFT TURN LANES GREATER THAN 355 FT

NOT TO SCALE

MICHIGAN DEPARTMENT OF TRANSPORTATION
BUREAU OF DEVELOPMENT STANDARD PLAN

09/21/20
F.H.W.A. APPROVAL

03/25/20
PLAN DATE

PAVE-935-E

SHEET
3 OF 6

NOTE: THE ORIGINAL SIGNED COPY IS KEPT ON FILE AT THE MICHIGAN DEPARTMENT OF TRANSPORTATION.

LEFT TURN LANE TREATMENTS BETWEEN URBAN SIGNALIZED INTERSECTIONS

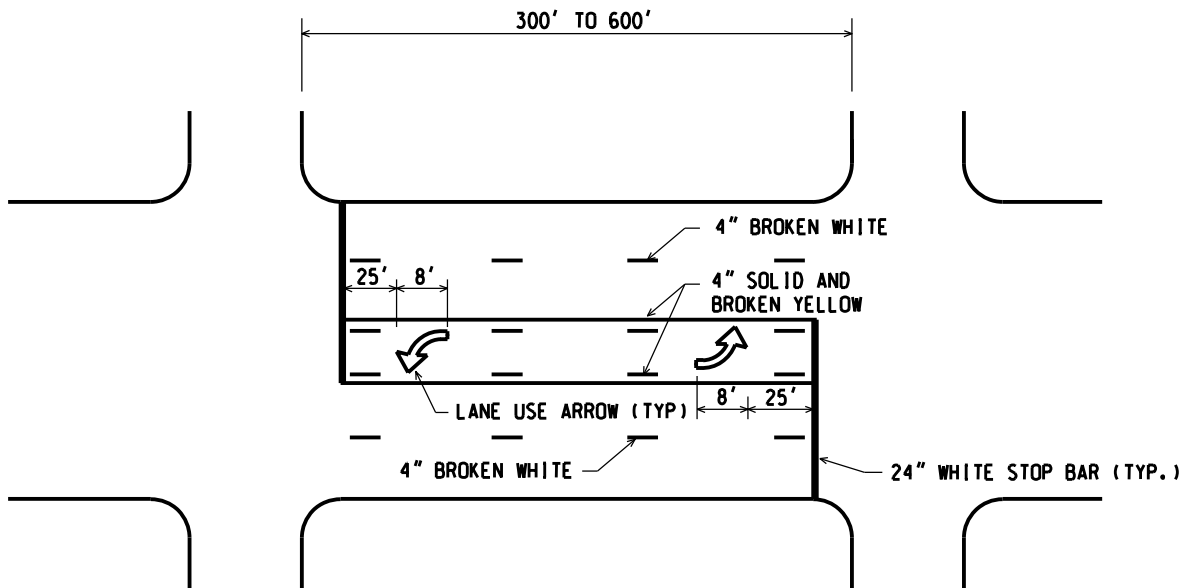

WHERE DISTANCE BETWEEN ADJACENT INTERSECTIONS IS 600 FT OR LESS

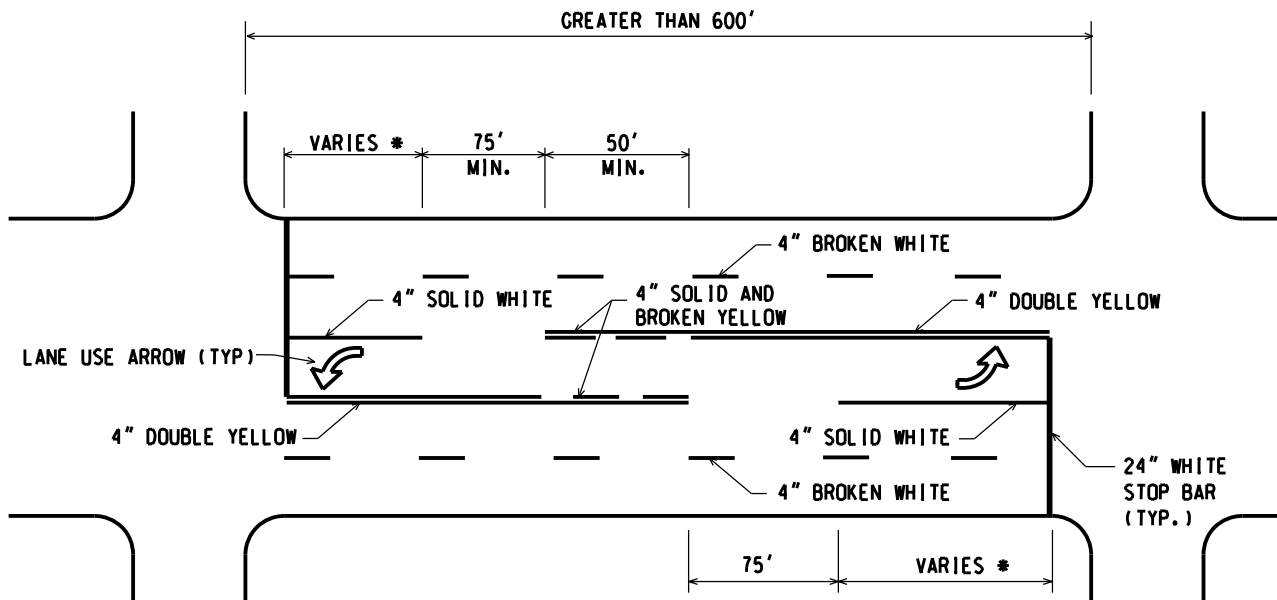

WHERE DISTANCE BETWEEN ADJACENT INTERSECTIONS IS GREATER THAN 600 FT

* LENGTH DETERMINED BY TRAFFIC COUNT ANALYSIS

NOT TO SCALE

MICHIGAN DEPARTMENT OF TRANSPORTATION
BUREAU OF DEVELOPMENT STANDARD PLAN

09/21/20
F.H.W.A. APPROVAL

03/25/20
PLAN DATE

PAVE-935-E

SHEET
4 OF 6

NOTE: THE ORIGINAL SIGNED COPY IS KEPT ON FILE AT THE MICHIGAN DEPARTMENT OF TRANSPORTATION.

TWO-WAY LEFT-TURN LANE MARKINGS

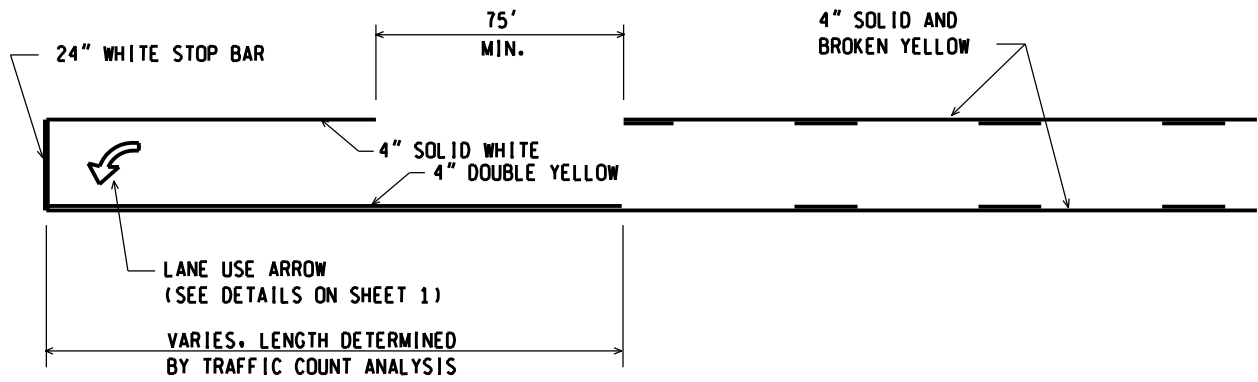

SINGLE-DIRECTION LEFT TURN CHANNELIZATION

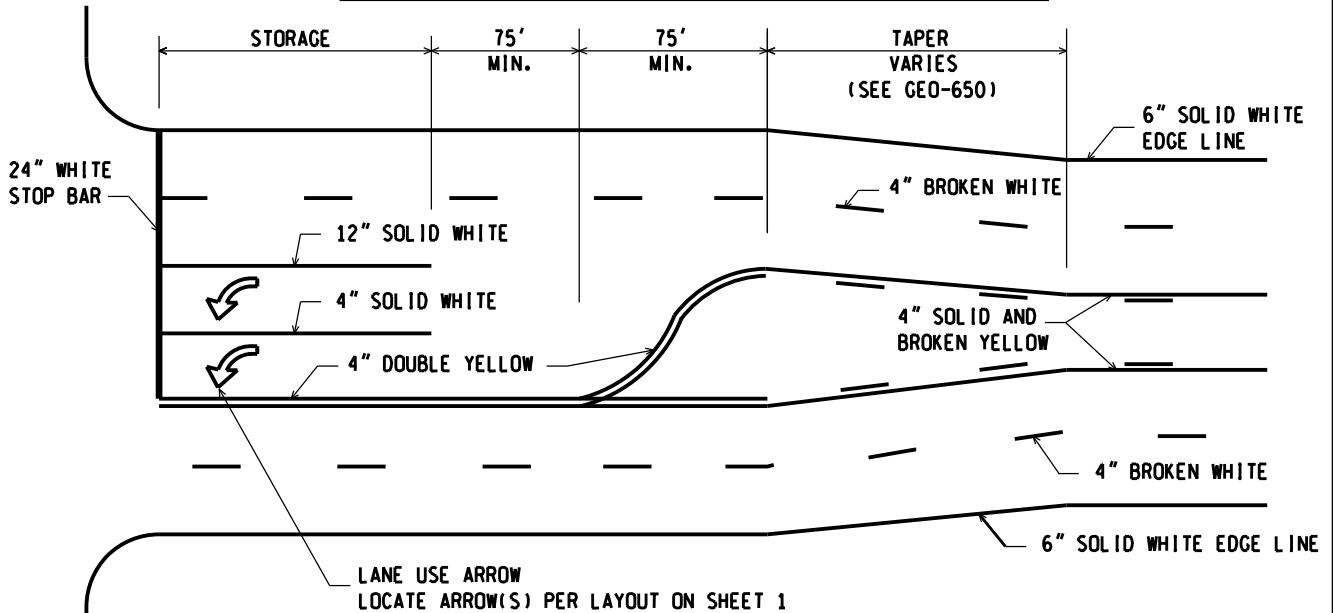

SINGLE-DIRECTION LEFT TURN CHANNELIZATION FOR DUAL TURNS (PAVEMENT WIDENING ON BOTH SIDES)

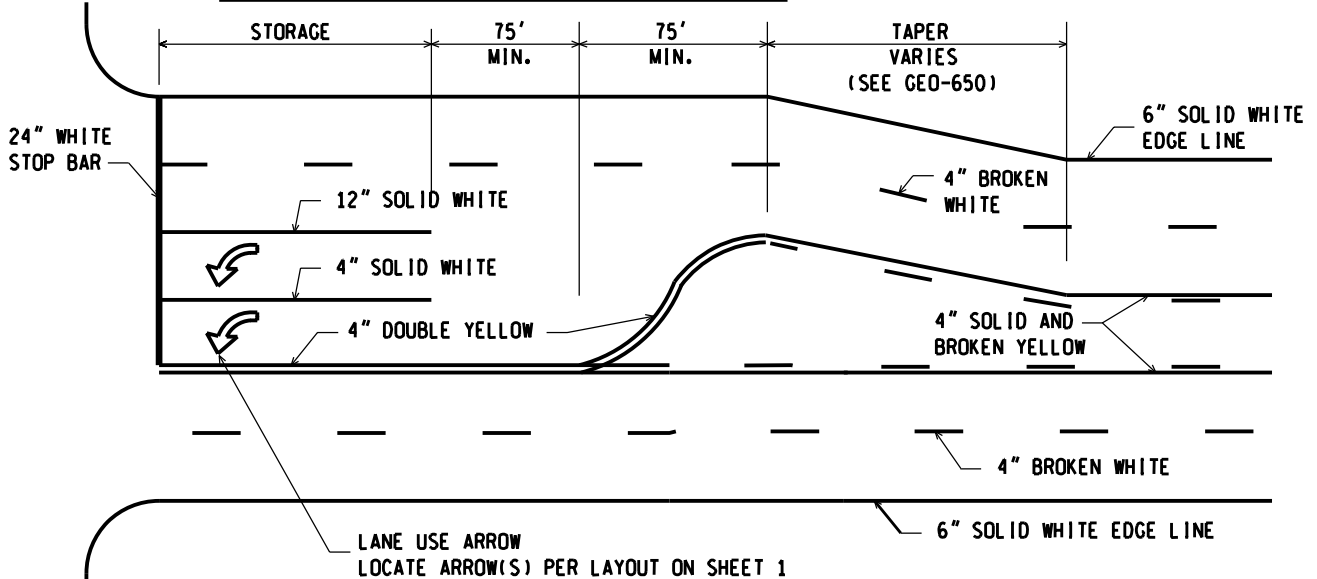

SINGLE-DIRECTION LEFT TURN CHANNELIZATION FOR DUAL TURNS (PAVEMENT WIDENING ON ONE SIDE)

NOT TO SCALE

TWO-WAY LEFT-TURN LANE MARKINGS

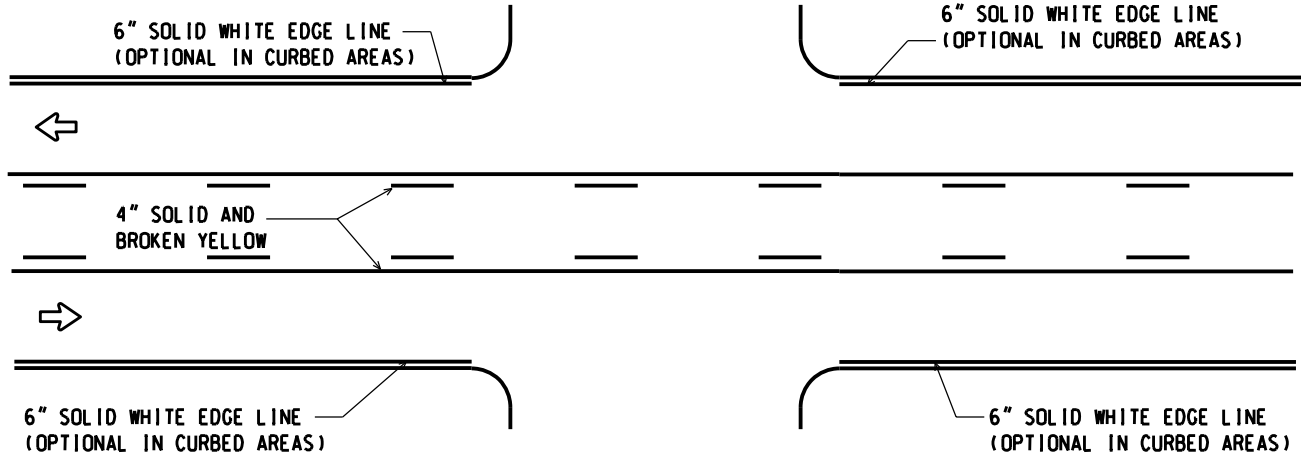

CONVENTIONAL MARKINGS AT STOP CONTROLLED INTERSECTIONS

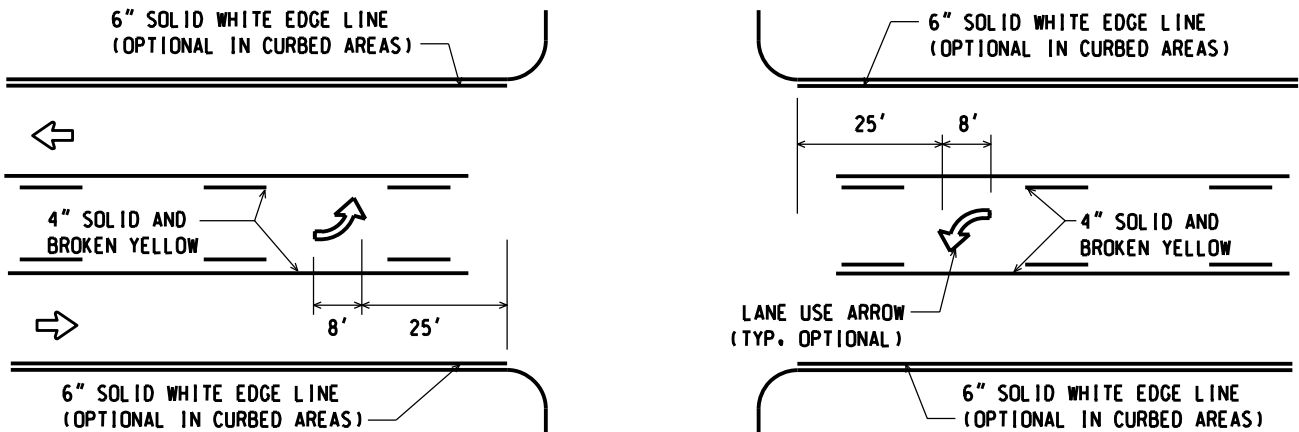

ALTERNATE MARKINGS AT STOP CONTROLLED INTERSECTIONS

NOT TO SCALE

MICHIGAN DEPARTMENT OF TRANSPORTATION
BUREAU OF DEVELOPMENT STANDARD PLAN

09/21/20
F.H.W.A. APPROVAL

03/25/20
PLAN DATE

PAVE-935-E

SHEET
6 OF 6

NOTE: THE ORIGINAL SIGNED COPY IS KEPT ON FILE AT THE MICHIGAN DEPARTMENT OF TRANSPORTATION.