

Timing Issues for Traffic Signals Interconnected with Highway-Railroad Grade Crossings

Final Report

ORBP Reference Number: OR10-031



Authors:

Tapan K. Datta, Ph.D., P.E.

Timothy J. Gates, Ph.D., P.E., P.T.O.E.

Peter Savolainen, Ph.D., P.E.

Ahmad Fawaz

Amna Chaudhry

Wayne State University
Transportation Research Group
5050 Anthony Wayne Drive
Detroit, MI 48202

Prepared for:

Michigan Department of Transportation
Office of Research and Best Practices
425 West Ottawa
Lansing, MI 48933

February 19, 2013

Final Report

TIMING ISSUES FOR TRAFFIC SIGNALS INTERCONNECTED WITH HIGHWAY- RAILROAD GRADE CROSSINGS

ORBP Reference Number: OR10-31

Prepared for:

Michigan Department of Transportation
Office of Research and Best Practices
425 West Ottawa
Lansing, MI 48933

Prepared by:

Wayne State University
Transportation Research Group
5050 Anthony Wayne Drive
Detroit, MI 48202

Authors:

Tapan K. Datta, Ph.D., P.E.
Timothy J. Gates, Ph.D., P.E., P.T.O.E.
Peter T. Savolainen, Ph.D., P.E.
Ahmad Fawaz
Amna Chaudhry

February 19, 2013

Technical Report Documentation Page

1. Report No. RC-1578	2. Government Accession No. N/A	3. MDOT Project Manager Kris Foondle	
4. Title and Subtitle Timing Issues for Traffic Signals Interconnected with Highway-Railroad Grade Crossings		5. Report Date 2/19/2013	
		6. Performing Organization Code N/A	
7. Author(s) Tapan K. Datta, Timothy J. Gates, Peter T. Savolainen, Ahmad Fawaz, and Amna Chaudhry		8. Performing Org. Report No. N/A	
9. Performing Organization Name and Address Wayne State University Transportation Research Group 5050 Anthony Wayne Drive Detroit, Michigan 48202		10. Work Unit No. (TRAIS) N/A	
		11. Contract No. 2010-0298	
		11(a). Authorization No. Z2	
12. Sponsoring Agency Name and Address Michigan Department of Transportation Research Administration 425 West Ottawa Street Lansing MI 48933		13. Type of Report & Period Covered Final Report 8/1/2011 to 3/1/2013	
		14. Sponsoring Agency Code N/A	
15. Supplementary Notes			
16. Abstract <p>The coordination of highway-railroad grade crossing warning signals with nearby traffic signals is of vital importance due to potential safety consequences. Interconnections between traffic signals in close proximity to railroad crossings provide an important safety function by allowing the railroad warning system to preempt the normal traffic signal operation and provide special phasing to clear vehicles queued over the railroad tracks, prohibit others from joining the queue, and maintaining traffic flow for non-conflicting traffic movements. In Michigan, there are approximately 200 interconnected highway-railroad grade crossings that are all under regulatory control of the Michigan Department of Transportation. The MUTCD provides guidance concerning the use of preemption where the signalized intersection is within 200 feet of a railroad crossing. There is however, minimal guidance for locations where intersections are more than 200 feet beyond the railroad crossings. Some of these locations experience queuing problems due to high traffic volumes. The purpose of this research was to compile and review literature and current practices related to interconnected traffic signals and preemption in order to determine solutions for providing safe and efficient timings for the traffic signals and nearby highway-railroad grade crossing warning signals.</p> <p>A series of highway-railroad intersection configuration templates was developed as a part of this research. A set of guidelines was also developed with accompanying software to provide additional assistance for identification of possible interconnection locations that could utilize preemption concepts. The guidelines also assist in the determination of signal timing parameters for the phasing and timing design required as a part of the concept.</p>			
17. Key Words Railroad Crossing, Preemption, Interconnect, Warning Time, Template		18. Distribution Statement No restrictions. This document is available to the public through the Michigan Department of Transportation.	
19. Security Classification - report Unclassified	20. Security Classification - page Unclassified	21. No. of Pages 89	22. Price N/A

The opinions, findings, and conclusions expressed in this publication are those of the authors and not necessarily those of the Michigan State Transportation Commission, the Michigan Department of Transportation, or the Federal Highway Administration.

TABLE OF CONTENTS

	PAGE
I. INTRODUCTION AND BACKGROUND.....	1
Problem Statement.....	5
Research Objectives.....	5
II. SUMMARY OF STATE-OF-THE-ART AND PRACTICE.....	7
Federal Preemption Guidance.....	7
Identifying Locations for Preemption.....	8
Train Detection Systems and Interconnection Basics.....	8
Preemption Phasing	10
Pre-Signals	14
Current State-of-the-Practice	15
III. PROPOSED PREEMPTION DESIGN GUIDELINE.....	21
Entry into Preemption Mode.....	21
Right-of-Way Transfer Time	21
Clear Track Intervals.....	27
Dwell Phase	33
Exit Phase.....	34
IV. PROPOSED GUIDELINES FOR DETERMINING CLEARANCE DISTANCE.....	35
Gate and Pre-Signal Present.....	35
Gated Railroad Crossings Without Pre-Signal	40
Railroad Crossing in the Vicinity of a Boulevard.....	45
Diagonal Railroad Crossings	46
Railroad Crossings in the Middle of the Intersection	48
V. GUIDELINE FOR CALCULATING MINIMUM WARNING TIME.....	50
Examples.....	51
Determination of Queue Length	51
VI. ASSESSMENT OF EXISTING SIGNALIZED INTERSECTIONS WITH RAILROAD PREEMPTION.....	56
Preemption Design Templates	57

TABLE OF CONTENTS (Continued)

	PAGE
VII. USING THE RAILROAD PREEMPTION ASSESSMENT TOOL.....	58
Introduction.....	58
Running the Program	58
Entering Inputs.....	58
95 th Percentile Queue Calculation.....	61
VIII. CONCLUSION AND RECOMMENDATIONS.....	63
IX. IMPLEMENTATION STRATEGY.....	65
X. REFERENCES.....	66
APPENDIX A. EXISTING STATE DOT PREEMPTION SIGNAL TIMING TEMPLATES	A-1
APPENDIX B. LOCATION SUMMARY DATA FOR INTERCONNECTED RAIL- ROAD CROSSINGS/SIGNALIZED ROADWAY INTERSECTIONS IN MICHIGAN.....	B-1
APPENDIX C. TEMPLATES FOR TRAFFIC SIGNAL TIMING AND PHASING PLAN DESIGN	C-1

LIST OF FIGURES

	PAGE
Figure 1. Detection of Train Arrival Using Track-Circuitry (4).....	9
Figure 2. Example Basic Template for Signal Preemption Sequence (20).....	11
Figure 3. Example Signal Preemption Timeline (2)	13
Figure 4. Example of a Pre-Track Traffic Signal Installation (2).....	14
Figure 5. Warning Sign for Abbreviated Walk Time (used by IDOT).....	18
Figure 6. Measuring Intersection Width	27
Figure 7. Example 1 for Determining Track Clearance Green Time (One Truck in the Queue)	32
Figure 8. Example 2 for Determining Track Clearance Green Time (Two Trucks in the Queue).....	33
Figure 9. Changeable Message Sign and Head Signals to Restrict Turning Movements.....	34
Figure 10. Clearance Distance on a Two-Lane Roadway When Queue is Not Extending Beyond the Tracks (Gate and Pre-Signal Present).....	36
Figure 11. Clearance Distance on a Two-Lane Roadway When Queue is Extending Beyond the Tracks (Gate and Pre-Signal Present)	37
Figure 12. Clearance Distance on a Four-Lane Roadway When Queue is Not Extending Beyond the Tracks (Gate and Pre-Signal Present).....	38
Figure 13. Clearance Distance on a Four-Lane Roadway When Queue is Extending Beyond the Tracks (Gate and Pre-Signal Present)	38
Figure 14. Clearance Distance on a Roadway with an Exclusive Left-Turn Lane When Queue is Not Extending Beyond the Tracks (Gate and Pre-Signal Present)	39
Figure 15. Clearance Distance on a Roadway with an Exclusive Left-Turn Lane When Queue is Extending Beyond the Tracks (Gate and Pre-Signal Present)	40
Figure 16. Clearance Distance on a Two-Lane Roadway When Queue is Not Extending Beyond the Tracks (Gate Present Without a Pre-Signal).....	41
Figure 17. Clearance Distance on a Two-Lane Roadway When Queue is Extending Beyond the Tracks (Gate Present Without a Pre-Signal)	42

LIST OF FIGURES (CONTINUED)

	PAGE
Figure 18. Clearance Distance on a Four-Lane Roadway When Queue is Not Extending Beyond the Tracks (Gate Present Without a Pre-Signal).....	43
Figure 19. Clearance Distance on a Four-Lane Roadway When Queue is Extending Beyond the Tracks (Gate Present Without a Pre-Signal)	43
Figure 20. Clearance Distance on a Roadway with Exclusive Left-Turn Lane When Queue is Not Extending Beyond the Tracks (Gate Present without a Pre-Signal)	44
Figure 21. Clearance Distance on a Roadway with an Exclusive Left-Turn Lane When Queue is Extending Beyond the Tracks.....	45
Figure 22. Clearance Distance When Railroad Crossing is Located near a Signalized Boulevard Intersection	46
Figure 23. Skewed Railroad Crossing Two Approaches Near a Signalized Intersection.....	47
Figure 24. Advance Preemption Chart.....	48
Figure 25. Railroad Crossing Through the Middle of a Normal Signalized Intersection.....	49
Figure 26. Minimum Track Clearance Distance (13)	50
Figure 27. Cycle Capacity Probability Design Curves (40)	55

LIST OF TABLES

Table 1. Track Clearance Green Time for a Clearance Distance ‘L’ (Passenger Cars Only)	29
Table 2. Track Clearance Green Time for a Clearance Distance ‘L’ (Passenger Cars + One Truck)	29
Table 3. Track Clearance Green Time for a Clearance Distance ‘L’ (Passenger Cars + Two Trucks)	30
Table 4. Vehicle Length Adjustment Factors Based on Truck Percentages.....	62

I. INTRODUCTION AND BACKGROUND

Highway-railroad crossings pose a unique set of safety challenges that require regulatory agencies and railroads to work together to alleviate safety and operational issues. Highway-railroad at grade crossings may be controlled by various traffic control devices including signs, pavement markings, flashing red light signals, gates and other directional separators. The criteria for installation of most of these devices are standardized. Crossing gates and other active devices are used where the potential for vehicle-train crashes is elevated due to the increased frequency of trains and vehicular traffic, as well as sight constraints and roadway configuration issues. Additional safety challenges arise at highway-railroad grade crossings in close proximity to signalized traffic intersections.

Shortly after the tragic collision of a commuter train with a school bus in Fox River Grove, a suburb of Chicago, Illinois, that resulted in seven deaths on October 25, 1995, former U.S. Secretary of Transportation Federico Peña asked Michael Huerta, the Associate Deputy U.S. Secretary of Transportation to lead a task force to investigate the issues related to highway-railroad grade crossing safety. The objective of this task force was to review the decision making process for designing, constructing, maintaining, and operating highway-railroad grade crossings (*1*). This report looked at the highway-railroad grade crossing-related issues and provided a comprehensive report to then Secretary of Transportation Rodney E. Slater in June of 1997.

The report (*1*) included a statement that “It has been a long-standing and desirable engineering practice to preempt highway intersection traffic signals in close proximity to highway-railroad grade crossings that have active warning devices. The purpose of the preemption is to allow sufficient time for any motor vehicle inadvertently stopped on a highway-railroad grade crossing to proceed off the track prior to the arrival of a train.” (*1*) As a response to this report, all states actively pursued interconnection of traffic signals located in close proximity to highway-railroad crossings. They also started reviewing at grade crossings that were known to have a crash history and/or anecdotal evidence of numerous traffic control device violations.

Traffic crashes at highway-railroad grade-crossings account for a significant loss of property and life in Michigan. A review of available federal and state statistics (FRA car-train crash reports and State Police UD-10 files) reveals a current five-year average of approximately

50 crashes per year. These car-train crashes resulted in an average of 5 fatalities (10%) and 19 (38%) injuries per year. In comparison, the severity of train-involved crashes at highway-railroad grade crossings is significantly higher when compared to crash severity generally encountered at roadway intersections. Crashes at all highway/roadway intersections experienced 0.27% of fatalities and 24.3% of injuries. These statistics clearly demonstrate that car-train crash events are significantly more likely to result in fatalities and injuries than other highway intersection crashes.

One of the most challenging traffic control issues associated with highway-railroad grade crossings involves the close proximity of signalized intersections. Safety concerns occur when a train arrives and traffic from the signalized intersection has queued back onto the tracks. Similarly, traffic flow issues arise when traffic queued for a train arrival spills back onto the intersection. To alleviate both safety and operational issues associated with signalized intersections that are in close proximity to a highway-railroad grade crossing, it is necessary to coordinate or “interconnect” railroad signals with traffic signals at nearby intersections. This coordination is often performed using a special signal “preemption” strategy which transfers the traffic signal from the normal operational mode to a special control mode upon detection of an arriving train (2).

The need for preemption arises due to the differences in the right-of-way assignment principles between roadway and railroad signals (i.e., approaching trains ALWAYS have the right-of-way, while roadway signals alternately assign right-of-way based on time or actuation). Due to these differences, adjacent roadway traffic signals MUST be preempted by an arriving train, to give it priority over all other movements. The objective of a preempt is to take control of the nearby traffic signal to provide for the safe passage of a train, no matter what the status of the normal traffic signal operation at the time the preemption occurs (3). Successful traffic signal preemption provides two functions: 1) initially clears the tracks of any queued vehicles and 2) does not allow any movements that would intersect the tracks, as traffic may spill back into the intersection.

Issues associated with railroad-traffic signal preemption were brought to the national forefront in the aftermath of the previously referenced 1995 fatal train-bus crash in Illinois (4). This collision occurred because the rear of the bus protruded onto the tracks while stopped for a traffic signal on the adjacent roadway. The crash resulted in seven fatalities. Shortly after the

collision, state and federal transportation and railroad agencies began thorough investigations of their own policies and/or procedures to determine ways to minimize the occurrence of a similar situation within their jurisdiction. A national taskforce (assembled as a result of the collision) found two widespread issues associated with the interconnections between the railroad crossing and nearby traffic signals (2):

- No specific guidelines existed as to when to provide interconnection of highway-railroad grade crossings with nearby traffic signals at intersections, relative to the vehicle storage space between the intersection and the railroad crossing.
- Lack of effective communication between the multiple parties that are responsible for highway-railroad grade crossings.

The current MUTCD provides guidance as to when signal preemption should be provided (5). Section 8C.09 states that preemption should be provided if the intersection is located within 200 feet of a highway-railroad at grade crossing, although intersections farther than 200 feet may be considered for preemption (5). Research has suggested that the need for preemption should be based on a detailed queuing analysis at each individual location, rather than a pre-specified distance (6). A nationwide survey found that many states desired additional guidance as to when to provide preemption, as it was often deemed necessary well beyond the 200 foot rule (4). Factors that were suggested for consideration when determining the need for preemption included traffic volumes, number of lanes, traffic signal timing, saturation flow rates, vehicular arrival characteristics and vehicle type. The MUTCD in Section 4D.27.08 disallows the shortening and/or omission of the yellow and all-red intervals when a preemption call is placed, but does allow for the shortening or omission of pedestrian “walk” and flashing “don’t walk” intervals (7).

Methods for inputting preemption routines depend on the traffic signal controller. Most modern traffic signal controllers allow for several default and user-programmable preemption routines including those for railroad crossings (4).

Federal law requires that a minimum of 20 seconds of warning time to roadway users must be provided by the railroad crossing signal prior to a train arriving at the crossing (8). The use of preemption at an intersection may require detecting the train much sooner than 20 seconds to adequately clear vehicles off the tracks. The train detection system must extend far enough

along the tracks, to detect the fastest allowable train, to provide 20 seconds of warning time (or more, if preemption is needed). Calculation of the maximum amount of preemption time needed for the traffic signals depends on several factors, such as the time needed for right-of-way transfer time, queue clearance time, and additional separation time between the queue clearance and train arrival.

In order for preemption to work effectively, a high level of motorist compliance is necessary both at the crossing and nearby intersection. Violations, such as crossing the tracks when the railroad signals are flashing or driving around gates, will increase the risk of crash occurrence regardless of the signal preemption strategies. In addition, violations at nearby signalized intersections that include red-light-running or jaywalking by pedestrians will also have a negative impact on the ability to effectively clear the tracks of any queued vehicles.

The literature has suggested that the greatest challenges associated with safe and efficient preemption timing are connected with 1) terminating the current phase when preemption is called, particularly if a pedestrian clearance phase is required, and 2) determining adequate track clearance time. While allowable by the MUTCD, it is not desirable to prematurely terminate the pedestrian clearance phase. However in some instances terminating the pedestrian clearance phase may be necessary to assure adequate track clearance time. Strategies have been suggested to help alleviate issues associated with prematurely terminating pedestrian clearance intervals due to train preemption, and include special train-activated signing for pedestrians (4), and auxiliary detection systems strictly for pedestrian clearance protection (9-11). Various strategies have been offered for determination of the track clearance green interval, some of which are based on real-time presence data for the queue storage area (12). The most important considerations for timing of the track-clearance green interval are start-up delay and repositioning time (13), which are largely dependent on vehicle type/length. For example, queues that include only short passenger vehicles cause the longest start-up delays, whereas the same queue distance composed of heavy trucks only will have the longest repositioning time. Strategies for providing the optimal preemption timing plan to minimize the impacts on a dense network of signals have also been utilized (14).

Pre-track signals (or pre-signals) are often used in Michigan and other states as a means by which to ensure that the tracks remain clear. Pre-signals are positioned prior to the railroad grade crossing and the intersection for traffic heading towards the intersection. Pre-signals are

coordinated with the intersection traffic signals in a similar manner to the paired signals at a divided roadway intersection, in that the pre-signal changes to red several seconds prior to the signal at the intersection (i.e., the downstream signal), thereby allowing all vehicles ample time to clear the tracks. Pre-signals provide the advantage of keeping the tracks clear during every cycle regardless of whether a train is arriving or not.

Problem Statement

The coordination of highway-railroad grade crossing signals with nearby traffic signals is an important issue within Michigan and nationwide. Proper coordination of railroad grade crossing signals with nearby traffic signals will allow vehicles to clear the tracks prior to train arrival, greatly reducing the risk of a vehicle becoming trapped on the tracks. Approximately 200 highway-railroad grade crossings with active warning devices that are interconnected with nearby roadway traffic signals exist in Michigan.

However, further benefits may be realized with improvements to systems and coordination efforts. A review of the UD-10 forms for the crashes that occurred at signal-controlled railroad crossings in Michigan between 2004 and 2009, revealed one track-queuing-related crash which occurred in Rockwood, Michigan in 2008. Although records show only one queue-related crash at a highway-railroad crossing interconnected with an adjacent signalized intersection, anecdotal evidence from field workers suggests a number of close calls have occurred in the past. As all public crossings are within MDOT's regulatory jurisdiction, this is an important issue for MDOT to address. Traffic signal interconnections at grade crossings often require an assessment of traffic queuing characteristics, traffic arrival patterns and intersection characteristics.

Research Objectives

The purpose of this research was to compile and review existing interconnection and preemption literature and practices to determine solutions to provide safe and efficient interconnection timings between nearby traffic signals and highway-railroad grade-crossing signals. It was desired to develop a series of templates that may be applied to any highway-railroad intersection configuration, with accompanying software to provide guidance for identifying possible candidate preemption locations. The research objectives were as follows:

- Identify all possible interconnected intersection and highway-railroad grade crossing configurations.
- Identify existing templates for developing preemption timing at interconnected highway-railroad grade crossings.
- Develop and/or compile criteria for addressing possible scenarios at an interconnected crossing requiring preemption.
- Develop a guidance document for use as an interconnect/preemption reference tool for highway and railroad engineers with companion software to assist in determining if a location is a candidate for preemption.

II. SUMMARY OF STATE-OF-THE-ART AND PRACTICE

Federal Preemption Guidance

At the time of the Fox River Grove crash and subsequent task force investigation, the Federal Manual on Uniform Traffic Control Devices (MUTCD) (1988 version) provided only limited guidance on the use of preemption, stating the following in Section 8C-6:

“When highway intersection traffic control signals are within 200 feet of a grade crossing, control of the traffic flow should be designed to provide the vehicle operators using the crossing a measure of safety at least equal to that which existing prior to the installation of such signals.”

The 1988 MUTCD also provided guidance against the use of preemption for railroad crossings beyond 200 feet, stating later on in Section 8C-6:

“Except under unusual circumstances, preemption should be limited to the highway intersection traffic signals within 200 feet of the grade crossing.”

The 2000 “Millennium” Edition of the MUTCD was the first MUTCD revision to occur after the comprehensive report produced by the task force. The 2000 MUTCD included newly revised language providing additional direction regarding railroad preemption, most significantly, the consideration for providing coordination between railroad and traffic signals at crossings located beyond 200 feet from the intersection. The specific language regarding railroad preemption exists in Section 8D.07 and is provided as follows:

“When a highway-rail grade crossing is equipped with a flashing-light signal system and is located within 60 m (200 ft) of an intersection or mid-block location controlled by a traffic control signal, the traffic control signal should be provided with preemption in accordance with Section 4D.13.

Coordination with the flashing-light signal system should be considered for traffic control signals located farther than 60 m (200 ft) from the highway-rail grade crossing. Factors

to be considered should include traffic volumes, vehicle mix, vehicle and train approach speeds, frequency of trains, and queue lengths.”

The preemption guidance that exists in the current (2009) MUTCD remains unchanged from the 2000 MUTCD language.

Identifying Locations for Preemption

Although the MUTCD provides relatively clear guidance on the use of preemption for signalized intersections within 200 feet of a roadway-highway grade crossings with signals, a nationwide survey found that many states desired additional guidance as to when to provide preemption, when they were beyond the 200 foot rule (4). Research has suggested that the need for preemption should be based on a detailed queuing analysis at each individual location, rather than a pre-specified distance, such as 200 feet (6). Researchers have recommended that the need for railroad preemption control should be determined based on the 95th percentile queue length determined either by using simulation or other analytical methods, as suggested by the MUTCD (15, 16). Prior research (6, 17-19) has suggested that the queue lengths from a traffic signal are primarily dependent on the 1) approach lane volumes, 2) cycle length, 3) effective green time, 4) turning movement type, 5) left turn signalization, and 6) arrival patterns.

Train Detection Systems and Interconnection Basics

Activation of the railroad warning devices is based on detection of an oncoming train most commonly generated using track circuitry. Two primary track circuitry based warning systems are utilized: (1) fixed distance and (2) constant warning time. An example of train detection using track-circuitry is shown in Figure 1.

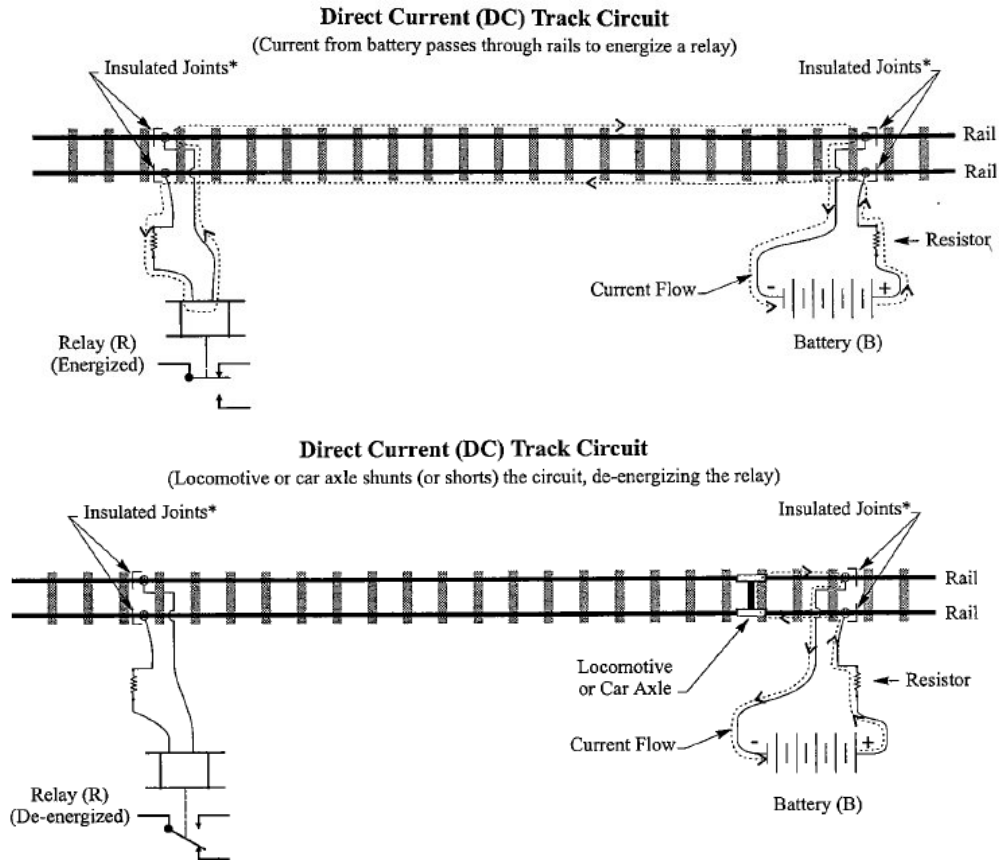

Figure 1. Detection of Train Arrival Using Track-Circuitry (4)

Fixed Distance System

In a fixed distance system, trains are detected upon reaching a specific location along the tracks. The limits of the track circuit are placed and established by the use of insulated joints in the rail that isolate the particular section of rail. Because a minimum warning time is required for all train arrivals, the track circuit must extend to a distance that enables the fastest approaching train to be detected. The distance from the crossing location that the detection circuitry must extend, is given by the following equation:

$$d_f = r_f \times MWT$$

where: d_f = approach circuit distance for the fastest train operating on the track

r_f = fastest allowable train speed for the track in question

MWT = minimum warning time provided to crossing users

Placement of detection circuitry according to the previous equation will conservatively trigger railroad warning devices when the train reaches the insulated joints in the rail. As these joints were located based on the fastest possible approaching train, the primary drawback to fixed distance detection is that excessive warning time is provided for slow moving trains. The actual amount of warning time provided by fixed distance detection systems can be determined based on the following equation:

$$t_a = d_a / r_a$$

where: t_a = warning time provided to motorists (sec)

d_a = approach circuit distance (ft)

r_a = speed of approaching train (ft/sec)

Therefore, if the circuitry was designed to provide 20 seconds of warning time for a maximum train approach speed of 40 mph, a train approaching at 10 mph will provide 80 seconds of warning time to motorists prior to arrival of the train at the crossing.

Constant Warning Time System

Constant warning time systems also utilize the track circuitry, but reduce excessive warning times caused by a slow moving train by predicting the train arrival time based on position and speed calculations. The grade-crossing warning devices are only activated when the train is located at the preselected minimum warning time away from the crossing. A late-1990's nationwide survey found that constant warning time arrival detection was one of the most common types of track circuits used (4).

Advanced Detection Technology

To help improve the reliability of train detection systems, advanced train detection technology is being developed and utilized in Michigan and elsewhere. These systems which do not utilize the standard track circuitry, are often based on GPS tracking from within the train itself, and have been developed to provide enhanced reliability of train arrival time prediction on high-speed rail corridors and improved cost-effectiveness with respect to installation and maintenance (4, 10, 11).

Preemption Phasing

Methods for inputting preemption routines depend on the traffic signal controller. Most modern traffic signal controllers allow for several default and user-programmable preemption routines

including those for railroad crossings (4). For the traffic signal controller to call a train preemption mode, data on the train arrival must be received from the interconnection circuit that runs from the railroad equipment to the appropriate interface (i.e., plug in location) on the traffic signal controller. Issues may arise with determining the appropriate interface location on the traffic signal controller as they are oftentimes labeled inconsistently or not at all (4). All modern traffic signal controller units provide the same basic train preemption sequence, which is depicted for a simple two-phase traffic signal and adjacent railroad crossing template as shown in Figure 2 (20). The basic preemption sequence includes (4):

- Entry into preemption mode,
- Termination of the current interval in operation,
- Initiation of “clear track” intervals,
- Initiation of preemption hold interval, and
- Return to normal operations.

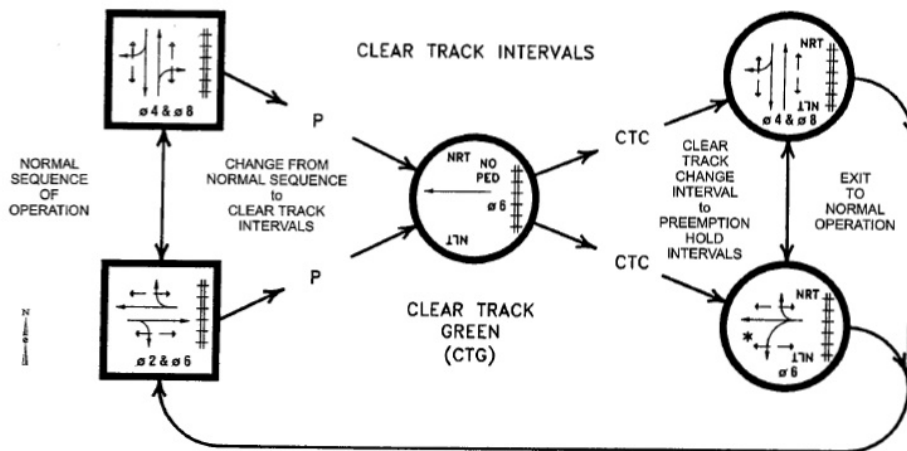

Figure 2. Example Basic Template for Signal Preemption Sequence (20)

Termination of Current Phase (Right-of-Way Transfer)

Ending the current phase consists of providing minimum green time, yellow change time and red clearance time. The minimum green time for the phase depends on agency practice, but may be omitted entirely. The MUTCD in Section 4D.27.08 does not allow the shortening and/or omission of the yellow and all-red intervals when a preemption call is placed. It does, however, allow for the shortening or omission of pedestrian “walk” and flashing “don’t walk” intervals (7). Literature has suggested that the greatest challenges associated with safe and efficient

preemption timing are related to 1) terminating the current phase when preemption is called, particularly if a pedestrian clearance phase is required, and 2) determining adequate track clearance time. Agencies commonly truncate or omit the pedestrian walk time (21). It is not desirable to terminate the pedestrian clearance phase, thus trapping pedestrians in the intersection. Premature termination of pedestrian clearance should only be used where it is required for track clearance as discussed earlier (page 4) in the report. A Texas study (21) suggested that standard preemption resulted in truncation of the pedestrian clearance phase for 40 percent of railroad preemption calls. Strategies have been suggested to help alleviate the issues associated with prematurely terminating pedestrian clearance intervals due to train preemption, and include special train-activated signing for pedestrians (4) and auxiliary detection systems strictly for pedestrian clearance protection (9-11). Improved transition preemption strategies eliminate pedestrian clearance phase truncation if warning times of at least 90 seconds are utilized (21).

Track Clearance Green Time

Various strategies have been used for the determination of track clearance green interval and some are based on real-time presence data for the queue storage area (12). Considerations for timing of the track-clearance green interval are, start-up delay and repositioning time (13), which are largely dependent on vehicle type/length. For example, queues that include only short passenger vehicles cause the longest start-up delay, whereas the same queue distance composed of heavy trucks will have the longest repositioning time. Strategies have also been developed for providing the optimal preemption timing plan to minimize impacts on a dense network of signals (14).

Railroad crossings which use preemption may experience “Preempt Trap”. This is when the track clearance phase ends before the gates and warning devices are activated (22). The Texas Transportation Institute recommended that the track clearance green duration should be equal to the expected preemption time plus 15 seconds (22).

Minimum Warning Time

Federal law requires that a minimum of 20 seconds of warning time to roadway users must be provided by railroad crossing signals prior to a train arriving at the crossing (8). The use of

preemption at an intersection may require detecting the train sooner than 20 seconds prior to arrival, in order to adequately clear vehicles off the tracks. The train detection system must extend far enough along the tracks to detect the fastest allowable train in order to provide 20 seconds of warning time (more, if preemption is needed). Calculation of the maximum amount of preemption time needed for the traffic signals depends on the time needed to transfer right-of-way, queue clearance time, and additional separation time between the queue clearance and train arrival. Marshall and Berg (15) recommended that the minimum warning time at a location with preemption should be based on the amount of time necessary to terminate the current phase, plus time necessary to clear any vehicle that may be stopped on the track, with an additional safety interval of 4 to 8 seconds. A recommended minimum green time of 10 to 12 seconds for right-of-way transfer is proposed while the time necessary to clear the tracks should be based on predicted queue length and types of vehicles in the queue. The preemption timeline and railroad crossing timeline are detailed in a generalized schematic in Figure 3 (2).

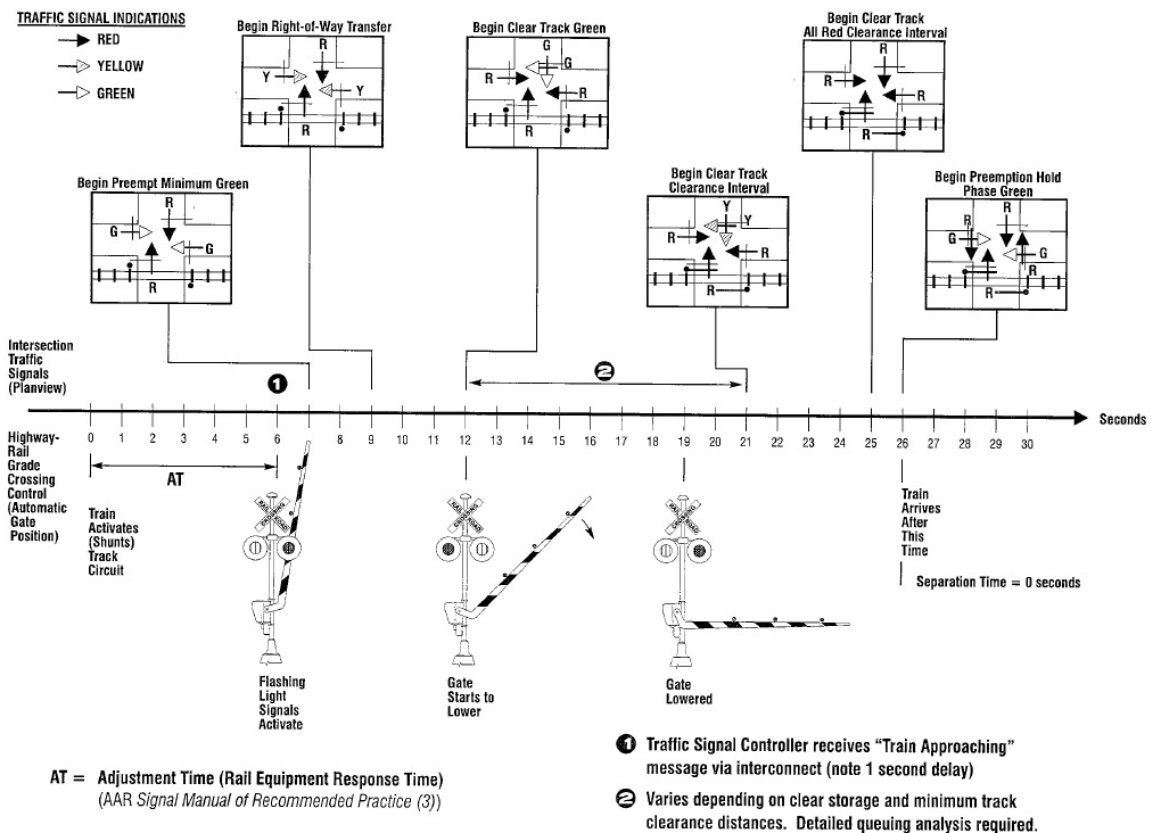

Figure 3. Example Signal Preemption Timeline (2)

Pre-Signals

Pre-signals are often used in Michigan and other states to ensure that the tracks remain clear of queued vehicles. Section 8C.09 of the federal MUTCD suggests that a pre-signal should be considered in advance of any highway-railroad grade crossing located within 50 feet (or within 75 feet at locations where multi-unit vehicles regularly use the roadway) of a signalized intersection (5). Pre-signals are positioned prior to the railroad crossing and intersection for traffic heading towards the intersection. They are coordinated with the intersection traffic signals in a similar manner to the paired signals at divided roadway intersections, in that the pre-signal changes to red, several seconds prior to the signal at the intersection (i.e., the downstream signal), thus allowing vehicles time to clear the tracks. Pre-signals provide the advantage of keeping the tracks clear during every cycle regardless of whether a train is arriving or not. An example of a pre-signal schematic is shown in Figure 4 (2).

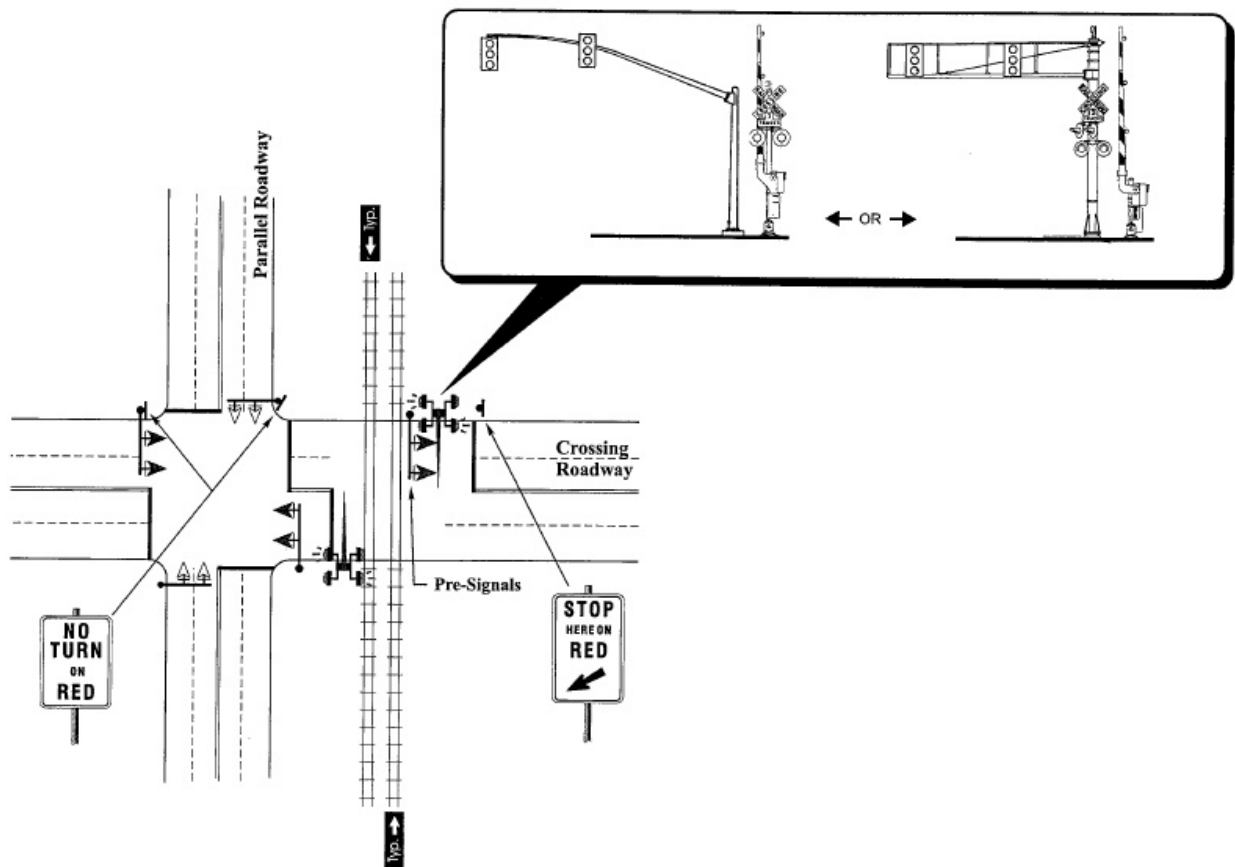

Figure 4. Example of a Pre-Track Traffic Signal Installation (2)

Current State-of-the-Practice

The policies and practices of state transportation agencies, published guidelines, state MUTCDs, and other available documents/manuals providing information on traffic signal preemption near highway-railroad grade crossings and intersections in close proximity were reviewed. Templates utilized by various states for railroad preemption signal timing are provided in Appendix A. The review focused on the following:

1. Signal Preemption Criteria
2. Pre-signal Criteria
3. Vehicular and Pedestrian Clearance Intervals
4. Queue Length Determination
5. Queue Clearance Time
6. Guidelines for Preemption Mode

Signal Preemption Criteria

A review of state DOT practices found that a variety of procedures exist to determine locations where railroad preemption should be applied. Most base their decision on the distance between the traffic signal and the railroad crossing – generally 200 feet per the MUTCD. However, some states consider other factors for signal preemption, such as queue length.

Consideration of Intersection Proximity

The MUTCD (5) considers intersection proximity as a critical factor for the interconnection of signals at a highway-railroad grade crossing intersections. It states that the interconnection of signals at the highway-railroad grade crossing occur if it is within 200 feet of a signalized intersection or midblock location. A review of the MUTCD supplements the available online data that found at least 22 states follow the 200 feet recommendation. For the others, preemption guidance is provided for intersections located at distances greater than 200 feet from the railroad grade crossing. Florida (23) suggests preempting the signals at intersections if a railroad grade crossing with active railroad warning devices is located 200 feet to 500 feet upstream. South Carolina provides similar guidance (24), recommending that the preemption be provided for intersections up to 500 feet away from the tracks.

Consideration of Other Factors

In instances where intersections are located more than 200 feet from the railroad crossing, MUTCD (5) provides several factors to be considered for signal preemption. These factors include traffic volumes, vehicle mix, queue lengths, vehicle and train approach speeds and frequency of trains. At least 18 states follow the guidance of the federal MUTCD when determining if interconnection is needed for signalized intersections located beyond 200 feet from the crossing. Some states provide additional guidance for locations beyond 200 feet, including more factors to be considered.

Tennessee (25) recommends providing signal preemption if queues routinely back up over the crossing during a portion of the day. Georgia (26) suggests giving additional consideration to duration of trains, frequency of vehicular queues, the complexity of existing signal system/phasing and whether opportunities exist to serve certain movements effectively during the period when trains are using the crossing. The New York MUTCD (27) states that when a signalized intersection is within 20 to 200 feet of a railroad crossing, factors that should be considered for interconnecting the signals include the geometric relationship between the crossing and intersection, crossing type (mainline/siding), vehicular volumes and speeds at the intersection and crossing, crash history, queue length, vehicle mix and other factors. The current Texas MUTCD recommends preemption for intersections within 200 feet of a railroad crossing. However, a report prepared by researchers at the Texas Transportation Institute (28) claimed the following: “A draft of the upcoming new release of the MUTCD suggests the queuing study should be performed when highway-rail intersections are located within 1000 feet of a signalized intersection.” The South Carolina DOT (24) in its Traffic Signal Design Guidelines (Chapter 6) addresses railroad preemption design. The factors and issues they described for consideration for interconnection of signals other than intersection proximity include:

1. Regular queuing during normal peak traffic times within track clearance distance
2. Signal timing adjustments do not resolve regularity of queuing
3. Presence of active railroad warning devices
4. Trains at the crossing have speeds higher than 20mph.

The Washington State DOT (29) signal design manual recommends considering/evaluating those railroad crossings for signal preemption that are within 500 feet of a signalized intersection.

Their guidelines provide several factors be considered for interconnection of such as 1) intersection proximity 200 feet or less (distance measured from the stop bar to far gate), 2) 95% maximum queue length (determined through queuing study or traffic simulation) reaching the tracks from stop bar, or 3) queue lengths affecting the upstream traffic signal.

Criteria for Pre-Signals

The MUTCD (5) suggests the use of pre-signals to control traffic approaching the crossing if it is located within 50 feet of a signalized intersection. In instances that a highway is regularly used by multi-unit vehicles, a distance of 75 feet should be considered. The pre-signals should be sequenced such that the area between the track and intersection is remained clear. The supplements developed by 16 states follow the same criteria for pre-signals consideration as provided in the MUTCD.

The Washington State DOT design manual (29) recommends pre-signals when the distance from the stop bar to the nearest rail is less than 88 feet (accommodating the longest design vehicle of 75 feet permitted by state statute and extra clearing storage). If there are no gates at the railroad crossing this distance should be considered up to 120 feet. The South Carolina DOT Traffic Signal Design Guidelines (24) recommend providing pre-signals, if no gates are present and the geometric design of the intersection allows vehicles to store within the clear storage distance (between the intersection and the at-grade crossing). If advanced preemption is provided, consideration is provided to the pre-signals to control traffic since the warning devices will not be activated until after the preemption clear sequence has started. If timed overlap is used, pre-signals are needed regardless of whether gates are present or not. If advanced preemption (not simultaneous preemption) is provided, the use of pre-signals is sufficient to control traffic since warning devices will not be activated until after the preemption clear sequence has begun.

Vehicular and Pedestrian Clearance Intervals

The MUTCD (7) guideline supplement of many states, including Michigan (30), has provided strategies for clearance intervals and pedestrian clearance intervals during the transition into preemption mode. They are:

- “The yellow change interval and red clearance interval shall not be shortened or omitted.”
- “The shortening or omission of any pedestrian walk interval and/or pedestrian change interval shall be permitted.”
- “The return to the previous steady green signal indication shall be permitted following a steady yellow signal indication in the same signal face, omitting the red clearance interval, if any.”

Guidelines for during preemption control and during the transition out of preemption control are as follows.

- “The shortening or omission of any yellow change interval and of any red clearance interval shall not be permitted.”
- “A signal indication sequence from a steady yellow signal indication to a steady green signal indication shall not be permitted.”

Shortening the pedestrian interval involves immediately terminating the WALK interval and implementing the abbreviated or no flashing DON’T WALK interval. A survey of state’s practices conducted as a part of NCHRP Synthesis 271 (4) indicated that the Illinois DOT installs a sign to warn the pedestrians about this shortened time (shown in Figure 5) at such locations. This is an uncommon practice elsewhere.

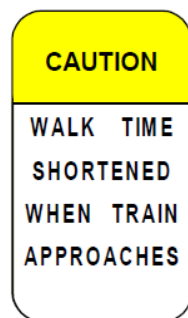

Figure 5. Warning Sign for Abbreviated Walk Time (Used by IDOT)

The Oregon Department of Transportation does not allow pedestrian clearance intervals to be truncated or terminated. Consequently, ODOT’s *Traffic Signal Guidelines (31)* require that the advance detection or warning system on the highway-railroad grade crossing be able to

provide complete pedestrian clearance interval. Their guidelines also allow “flashing yellow” indication when proper pedestrian clearance cannot be assured with green clearance. They suggest displaying a “PROCEED ON FLASHING YELLOW” sign during the flashing yellow track clearance phase.

Queue Length Determination

The Federal Highway Administration’s *Railroad Highway Grade Crossing Handbook* (32) provides procedures to determine queue length. It gives the following formulas for queue length determination.

$$L = 2qr (1+p) 25; v/c < 0.9$$

$$L = 2qr (1+\Delta x) (1+p) 25; 0.9 \leq v/c \leq 0.9$$

Where:

L= length of queue (ft)

q=vehicle flow rate (veh/lane/sec)

r=effective red time (red +yellow)

p=proportion of heavy vehicles in traffic flow (as a decimal)

25 represents the effective length of a passenger car, in feet

2 is an adjustment factor to account for random arrivals.

If the v/c ratio exceeds 1.0, or the intersection is over saturated, it is recommended to use the Highway Capacity Manual analysis or traffic simulation models (e.g., SimTraffic) to determine the 95th percentile queue length. Another alternative is direct observation at the location and then determining the 95th percentile queue length for a number of signal cycles during the peak hour.

Queue Clearance Time (Track Clearance Time)

There are a few states which provide recommendation regarding the queue clearance time (track clearance time) for the railroad preemption. The Texas Transportation Institute (TTI) “*Guide for Traffic Signal Preemption near Railroad Grade Crossing*” (28) used two empirical models

developed by Long, et al. in Florida (33) to determine time that is required by the design vehicle to start moving (start-up time) and the time required to accelerate and travel the clearance distance.

The Minnesota Department of Transportation (MnDOT) provides guidelines in its “*Guide for Determining Time Requirements for Traffic Signal Preemption at Highway-Rail Grade Crossings*” (34) to determine the time requirement for the track clearance green phase. The procedure they provide includes the time required for the design vehicle to start moving, as well as the time necessary for the vehicle to accelerate and travel the clearance distance. The time required for the vehicle to start moving is equal to 2 seconds, plus the queue start up distance, divided by the speed of the clearing shockwave of 20 feet per second. The acceleration and travel time varies based on type of vehicle and grade of the terrain.

Guidelines for Preemption Mode

Two states, Texas and Minnesota, have preemption design guidelines for all components of preemption, including right-of-way transfer time, clearance time (yellow and all red interval), and pedestrian clearance interval. MnDOT’s guidelines (34) for right-of-way transfer time calculation includes the preempt verification and response time and the worst-case conflicting vehicle time. The transition from normal operation to preemption mode requires a few seconds depending on the type of controller, and the type and length of track circuits used. Ending the current phase consists of providing minimum green time, yellow change time and red clearance time. The guide did not recommend an amount for the minimum green time, and instead refers to local policies. In case of the presence of a pedestrian phase, a comparison should be made between the pedestrian clearance time (Flashing Don’t Walk) and the sum of the minimum green time and yellow change time. The higher time value from the comparison governs the time necessary to end the current phase. Standard MnDOT practice is omitting the walk time and maintaining the required pedestrian clearance time. The Texas guidelines (28) define right of way transfer time as the maximum amount of time needed for the worst case condition, prior to display of the clear track green interval. It recommends considering the minimum green time and clearance times with the pedestrian clearance times during the right-of-way transfer from the normal to preemption operation.

III. PROPOSED PREEMPTION DESIGN GUIDELINE

Preemption is defined by the MUTCD as “*the transfer of normal operation of a traffic control signal to a special control mode of operation*”. It also states that the traffic signal preemption mode should be provided when a railroad crossing is within 200 feet of a signalized intersection, which would mean that the traffic signal controller and the highway-railroad grade crossing warning control shall be interconnected. In addition, pre-signals should be considered when a railroad crossing is located within 50 feet of an intersection, or 75 feet where multi-unit vehicles regularly use the road.

Preemption should be considered for signalized intersection approaches where it is predicted that a 95th percentile queue will spill back onto the crossing. In order to estimate 95th percentile queue lengths and provide guidance on preemption need in the vicinity of a crossing, a detailed queue study/analysis should be conducted. The queue analysis requires data for the critical approach(es) including traffic volumes, number of lanes, turn lane designation, signal phasing and timing, percentage of heavy vehicles, pedestrian traffic, and others. If the predicted 95th percentile queue reaches the railroad tracks and preemption is desired, the traffic signal must be interconnected to the active warning/flashing light system to allow implementation of safe clearance for traffic before arrival of a train.

The proposed guideline developed as a part of this research project provides steps necessary to determine each of the preemption signal phasing components needed to attain a safe and efficient operation. The proposed guideline is based on a combination of Michigan practice, practices of other states, and published research.

Entry into Preemption Mode

Generally, the traffic signal controller receives a signal from the railroad detection system that a train is approaching the crossing. The signal for entering into preemption mode is generated when the electric circuit is shunted or de-energized.

Right-of-Way Transfer Time

Right-of-way transfer time (RTT) is defined in the USDOT Railroad-Highway Grade Crossing handbook as “*The maximum amount of time needed for the worst-case condition, prior to*

display of the track clearance green interval. This includes any railroad or highway traffic signal control equipment time to react to a preemption call and any traffic control signal green, pedestrian walk and clearance, yellow change, and red clearance intervals for conflicting traffic” (32).

A preemption call can be initiated during any traffic signal phase. However, a transition phase is required to transfer the right-of-way from the normal operation mode to the approach where the railroad crossing is located. The phasing transition is a function of the minimum green intervals and the clearance intervals (yellow interval and red clearance interval). If an intersection has high pedestrian movement, the pedestrian clearance interval should also be considered when calculating the right-of-way transfer time.

Minimum Green Time

Most traffic signal controllers have the capability to be programmed to provide minimum green time when a preemption call is initiated. Drivers queued at traffic signals expect to have enough green time to cross the intersection. Suddenly aborting the green interval (i.e., after few seconds) on a preemption call could confuse drivers and result in rear end crashes. Therefore it is necessary to have a minimum green time to avoid traffic disturbance and assurance of the queue being cleared before the active phase is interrupted. Previous research studies recommend adopting minimum green intervals (pertaining to the normal operation mode) for the right-of-way transfer. It was noted from a review of some existing pre-signal timing charts that the value of 5 seconds was used more often than the others like 7 and 10 seconds.

The Michigan Signal Optimization Guidelines (6th Edition) (35) defines three types of minimum green time for traffic signals depending on the functional classification of highways and type of control for left turning movements, as presented below:

“Minimum green (minimum initial) intervals should be determined for each signal phase for the purposes of calculating a minimum split, as well as for any actuated or semi-actuated signals. Minimum green intervals should be applied as follows:

- **10.0 seconds** should be used for all major streets thru movements, including:
 - State trunk lines
 - Major arterial roadways
- **7.0 seconds** should be used for the following:
 - Minor cross-street movements (i.e., subdivision entrances, driveways, secondary roadways)
 - All left-turn phasing with the exception of actuated permitted-protected left-turn phasing (At locations with low turning volumes, the minimum green for left turn phases may be reduced to 5.0 seconds with approval of the MDOT project manager).
- **5.0 seconds** should be used for actuated permitted-protected left-turn phasing. A minimum vehicle recall will always be set for actuated permitted-protected left-turn phasing where a flashing red is used. Locations with a 5 section (doghouse) or the flashing yellow left-turn operation do not require the minimum vehicle recall for permitted-protected left-turn phasing.”

The main function of the preemption mode is to clear a vehicle trapped on the tracks. So, right-of-way transfer time should be reduced as much as possible and accordingly, it is recommended to use 5 seconds as the minimum green time.

Pedestrian Clearance Time

The MUTCD in Section 4D.27 (7) states that “*The shortening or omission of any pedestrian walk interval and/or pedestrian change interval shall be permitted*” during the transition into preemption mode. The ITE recommended practice for Preemption of Traffic Signals Near Railroad Crossings (36) indicates concern about the feasibility of reducing or eliminating the pedestrian clearance because vehicles in the front tend to yield for pedestrians which prevent vehicles behind from clearing the tracks. Therefore, it is recommended to maintain the pedestrian clearance interval (during transition into preemption) particularly for the locations where there is high pedestrian activity, such as at urban intersections.

Advance preemption is a better option than the simultaneous preemption when a pedestrian clearance interval is required. The traffic signal controller receives the advance preemption call and initiates the termination of the normal operation active phase, while the warning devices at the railroad crossing are not active. This leads to having most of the warning time diverted for clearing the tracks and also facilitates meeting the Michigan Railroad Code of 1993 (37) which requires the arrival of the train between 20 to 60 seconds from the activation of the railroad warning devices.

Based on the Michigan Signal Optimization Guidelines (6th Edition) (35), the “Flash Don’t Walk” (FDW) interval should be calculated as follows:

$$FDW^* = \frac{\text{Distance from curb to curb (feet)}}{3.5 \text{ (feet per second)**}}$$

* Round FDW up to next whole number

** Assumed walking speed

The review of the signal timing plans for the 42 interconnected state trunkline intersections found that the pedestrian clearance interval calculated for those intersections ranges from 13 to 29 seconds. The MUTCD in Section 8C.04 (5) allows the gate arm to start its downward motion after 3 seconds from activation of flashing light signals, but it shall reach the horizontal position at least 5 seconds before the arrival of the train. There is the possibility that the gate being half way to the horizontal position before the track clearance phase starts, can create a situation where the vehicle is partially or fully under the gate arm. This justifies the selection of the advance preemption mode when the pedestrian clearance interval is required.

Yellow Clearance Interval

The MUTCD in Section 4D.27 (7) states that “*The yellow change interval, and any red clearance interval that follows, shall not be shortened or omitted.*” The initiation of the preemption mode can take place during any phase in the normal operation mode. Therefore, the yellow clearance interval during the transition to preemption mode should account for the worst-case scenario which can be met by selecting the maximum yellow clearance interval pertaining to all the approaches.

Michigan Signal Optimization Guidelines (6th Edition) (35) present the method for calculation of the yellow clearance interval as shown below:

“Calculation of yellow clearance intervals (after both through and left-turn phases) shall adhere to the following methodology:

- *The range of the yellow interval shall be 3.5 to 5.0 seconds. Calculated intervals less than 3.5 seconds shall be increased to 3.5 seconds.*
- *Yellow intervals shall be rounded to the nearest 1/10th of a second.*
- *The following formula shall be used to calculate the yellow interval:*

$$Y = t + \frac{V}{2a \pm 64.4g}$$

Where: Y = yellow change interval (seconds)

t = Perception-reaction time (second)

V = Approach speed (feet/second)

a = Deceleration rate (feet/sec²)

g = grade of approach, in percent divided by 100 (downhill is negative)

- *Use the following predetermined values in the above formula when calculating the yellow interval:*

t = 1.0 second;

a = 10 feet/sec²

V = speed limit; for driveways/malls, freeway ramps and crossovers use 25 mph”

Red Clearance Interval

Similar to the yellow clearance interval, it is recommended selecting the maximum red clearance interval pertaining to all approaches during the transition into preemption mode. Michigan Signal Optimization Guidelines (6th Edition) (35) presents the method for the calculation of the red clearance interval as shown below:

“Calculation of all-red clearance intervals (after both through and left-turn phases) shall adhere to the following methodology:

- The all-red interval cannot be less than 1 second or greater than 2.5 seconds. In certain circumstances, such as at a SPUI intersection, 2.5 seconds of all-red time may not be enough time for a vehicle to clear the intersection and additional all-red time must be provided to ensure safe operations. Exceeding the all-red clearance interval maximum requires the approval of the MDOT project manager.*
- The following formula shall be used to calculate the all-red clearance interval:*

$$AR = \frac{W + L}{V}$$

Where:

w = Width of intersection, measured from the near-side stop bar to the far edge of the conflicting extended travel lane along the actual vehicle path of a through vehicle (feet). The measurement should include any right-turn lanes as conflicting lanes of traffic. At “T” intersections, “w” is measured from the near-side stop bar to the opposing curb in the path a through vehicle would travel. Figure 6 illustrates how “w” is measured for both a standard 4-leg intersection and a “T” intersection. The intersection width should be rounded up to the nearest 5-foot increment.

L = Length of vehicle (feet)

V = Approach speed (feet/second)

- Use the following predetermined values in the above formula when calculating the all-red interval:*

L = 20 feet

V = speed limit; for driveways/malls, freeway ramps and crossovers use 25 mph”

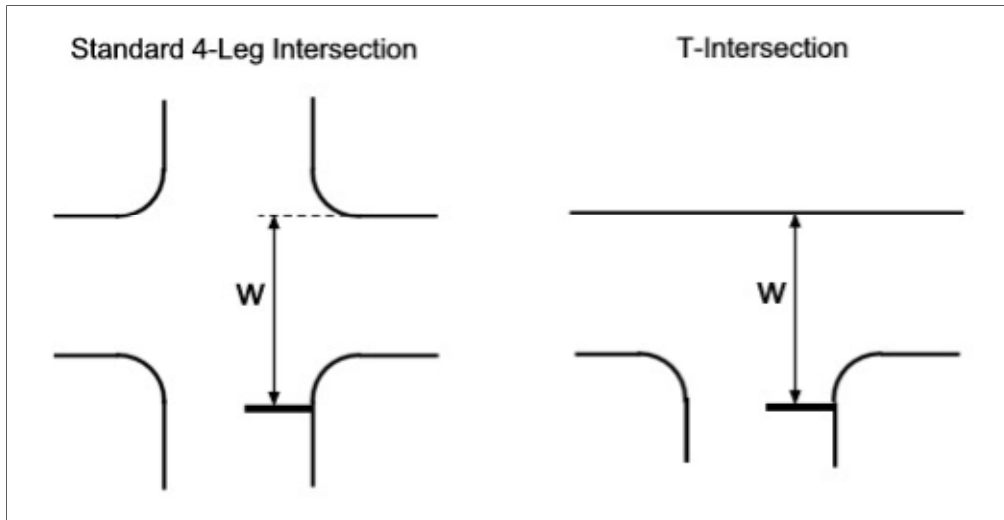

Figure 6. Measuring Intersection Width

Clear Track Intervals

Both EPIC/EF-140 and EPAC controllers, utilized in Michigan, have four intervals included in the track clearance phase. Those intervals are: the track green time, the track pedestrian clearance, the yellow clearance interval and the red clearance interval.

The track pedestrian clearance is generally not used because it is expected in most cases that the track green time is the dominant factor. Only one of the 42 reviewed signal timing plans had a track pedestrian clearance. This may be due to the track green time for that intersection being higher than the pedestrian clearance interval.

Track green time (or queue clearance time) is defined in the USDOT Railroad-Highway Grade Crossing handbook (32) as *“The time required for the design vehicle of maximum length stopped just inside the minimum track clearance distance to start up, move through, and clear the entire minimum track clearance distance. If pre-signals are present, this time shall be long enough to allow the vehicle to move through the intersection or to clear the tracks if there is sufficient clear storage distance. If a four-quadrant gate system is present, this time shall be long enough to permit the exit gate arm to lower after the design vehicle is clear of the minimum track clearance distance.”* The track clearance phase includes the following four intervals:

1. Minimum track clearance green time
2. Track pedestrian clearance interval
3. Yellow clearance interval
4. All red clearance interval

Minimum Track Clearance Green Time

The minimum track clearance green time is determined based on time necessary for a vehicle stopped on the tracks to safely enter the intersection. It is equal to the sum of (1) the start-up delay for a vehicle positioned on the tracks and (2) the subsequent travel time for the vehicle to enter the intersection, which is determined as follows:

1. Start-up delay time. This is equal to the time for the vehicle positioned on the tracks to start moving after the start of the green indication. It is influenced by both the type and number of vehicles in the queue.
2. Travel time for the vehicle to enter the intersection. This is a function of the clearance distance, approach grade, and vehicle type after the initial start-up delay.

This procedure is based on the methodology described in references (33) and (38). Tables 1, 2 and 3 present the total track clearance green time required to clear a standing queue of length 'L', which represents the distance from the near edge of the intersection **across the tracks to the far side gate or flashers**. Vehicle lengths of 25 feet and 61 feet are assumed for each passenger vehicle and WB-50 (50 feet total wheelbase) tractor trailer truck, respectively, are utilized to determine the start-up delay and travel time to enter the intersection. Table 1 specifically presents the track clearance time considering only passenger cars in the queue. Tables 2 and 3 calculate the queue clearance time considering passenger cars with one and two WB-50 trucks positioned at the end of the queue. Flat grades are assumed for both. Yellow and all-red clearance intervals must also be utilized, per MDOT standard clearance interval calculation procedures.

Table 1. Track Clearance Green Time for a Clearance Distance ‘L’ (Passenger Cars Only)

NUMBER OF PASSENGER CARS IN QUEUE*	L = CLEARANCE DISTANCE (FT)	START UP DELAY TIME (S)	TRAVEL TIME TO ENTER INTERSECTION AFTER INITIAL START UP DELAY (S)	TOTAL TRACK CLEARANCE GREEN TIME (S)	TRACK CLEARANCE GREEN TIME ROUNDED VALUES (S)
1	25	2.2	3.0	5.2	10.0
2	50	3.4	4.3	7.7	10.0
3	75	4.6	5.3	9.9	10.0
4	100	5.7	6.3	12.0	12.0
5	125	6.9	7.1	14.0	14.0
6	150	8.1	7.9	16.0	16.0
7	175	9.3	8.5	17.8	18.0
8	200	10.5	9.3	19.8	20.0
9	225	11.7	10.0	21.7	22.0
10	250	12.8	10.6	23.4	24.0
11	275	14.0	11.4	25.4	26.0
12	300	15.2	11.8	27.0	27.0
13	325	16.4	12.4	28.8	29.0
14	350	17.6	13.0	30.6	31.0
15	375	18.8	13.6	32.4	33.0
16	400	20.0	14.1	34.1	35.0

*Each car is assumed as 25 feet, which includes nominal buffer spacing.

Table 2. Track Clearance Green Time for a Clearance Distance ‘L’ (Passenger Cars + One Truck)

NUMBER AND TYPE OF VEHICLES IN QUEUE*	L = CLEARANCE DISTANCE (FT)	START UP DELAY TIME (S)	TRAVEL TIME TO ENTER INTERSECTION AFTER INITIAL START UP DELAY (S)	TOTAL TRACK CLEARANCE GREEN TIME (S)	TRACK CLEARANCE GREEN TIME ROUNDED VALUES (S)
1 truck	61	4.0	10.5	14.5	15.0
1 car + 1 truck	86	5.2	12.5	17.7	18.0
2 cars + 1 truck	111	6.4	14.3	20.7	21.0
3 cars + 1 truck	136	7.5	15.9	23.4	24.0
4 cars + 1 truck	161	8.7	17.3	26.0	26.0
5 cars + 1 truck	186	9.9	18.7	28.6	29.0
6 cars + 1 truck	211	11.1	20.0	31.1	32.0
7 cars + 1 truck	236	12.3	21.3	33.6	34.0
8 cars + 1 truck	261	13.5	22.5	36.0	36.0
9 cars + 1 truck	286	14.6	23.6	38.2	39.0
10 cars + 1 truck	311	15.8	24.7	40.5	41.0
11 cars + 1 truck	336	17.0	25.7	42.7	43.0
12 cars + 1 truck	361	18.2	26.7	44.9	45.0
13 cars + 1 truck	386	19.4	27.7	47.1	48.0
14 cars + 1 truck	411	20.6	28.7	49.3	50.0

*Each car is assumed as 25 feet, while each truck is assumed as 61 feet, representing a WB-50 tractor trailer. The vehicle lengths also include nominal buffer spacing. The truck is assumed to be positioned at the end of the queue.

Table 3. Track Clearance Green Time for a Clearance Distance ‘L’ (Passenger Cars + Two Trucks)

NUMBER AND TYPE OF VEHICLES IN QUEUE*	L = CLEARANCE DISTANCE (FT)	START UP DELAY TIME (S)	TRAVEL TIME TO ENTER INTERSECTION AFTER INITIAL START UP DELAY (S)	TOTAL TRACK CLEARANCE GREEN TIME (S)	TRACK CLEARANCE GREEN TIME ROUNDED VALUES (S)
2 trucks	122	7.0	16.0	23.0	23.0
1 car + 2 trucks	147	8.2	17.6	25.8	26.0
2 cars + 2 trucks	172	9.4	19.0	28.4	29.0
3 cars + 2 trucks	197	10.6	20.3	30.9	31.0
4 cars + 2 trucks	222	11.8	21.6	33.4	34.0
5 cars + 2 trucks	247	13.0	22.8	35.8	36.0
6 cars + 2 trucks	272	14.2	24.0	38.2	39.0
7 cars + 2 trucks	297	15.4	25.1	40.5	41.0
8 cars + 2 trucks	322	16.6	26.2	42.8	43.0
9 cars + 2 trucks	347	17.8	27.2	45.0	45.0
10 cars + 2 trucks	372	19.0	28.2	47.2	48.0
11 cars + 2 trucks	397	20.2	29.2	49.4	50.0

*Each car is assumed as 25 feet, while each truck is assumed as 61 feet, representing a WB-50 tractor trailer. The vehicle lengths also include nominal buffer spacing. The truck is assumed to be positioned at the end of the queue.

Queue clearance time is a function of many factors such as the queue length, type of vehicle, driver behavior, the acceleration of vehicles, and weather conditions. It is divided into two parts: 1) time required for the vehicle to start moving and 2) travel time of the vehicle to cross the intersection.

Start-up Time

For track clearance interval, the control vehicle is the last vehicle in the queue. The driver has to wait for the preceding vehicles before he is able to start moving. This start up time is influenced by the type and the number of vehicles in the queue. The Florida study (38) suggested using the simple linear model shown below for determining the time required for the nth vehicle to start moving:

$$d_n = \tau + n * T$$

Where

- d_n = Start up delay for the nth vehicle in a queue (sec)
 - τ = Excess startup time of the lead vehicle in a queue (sec)
 - n = Position of a specific vehicle in a queue ($n=1, 2, 3, \dots$) and
 - T = Uniform startup response time of each driver in a queue (sec)
- (Assumption: vehicle length = 25 feet)

T and τ values adopted by Texas Transportation Institute in “*Guide for Traffic Signal Preemption near Railroad Grade Crossing*” are used in this study project to determine the start-up time for passenger cars and WB 50 Trucks. The values are as follows.

Passenger car: $T = 1.2\text{s}$, $\tau = 1.0\text{ s}$

Truck WB 50: $T=1.0\text{s}$, $\tau = 3.0\text{ s}$

Vehicle Travel Time

It is the time necessary for the last vehicle in the queue to accelerate from the stopped condition and cross the intersection. The Florida study (33) develops a model to predict the travel distance of the vehicle as a function of the travel time and the grade of the roads:

$$d = \left(\frac{\alpha + Gg}{\beta}\right)t - \frac{\left(\frac{\alpha + Gg}{\beta} - v_0\right)(1 - e^{-\beta t})}{\beta}$$

d = Clearance distance in feet (includes rear bumper traveling length of the vehicle and the clearing distance)

t = Vehicle travel time (sec) from a stopped position to the distance ‘ d ’.

v_0 = Initial speed, set to 0 for starting from rest (fps)

G = Average road surface grade over repositioning distance, set to 0 for flat grade (ft /ft)

g = Gravitational constant (32.174 fps² near sea-level)

α = Initial vehicle acceleration from rest (fps²), and

β = rate of reduction in acceleration with increasing speed (sec⁻¹)

The values for α and β derived from the traffic observations in the study conducted by Gary Long (2000) are as follows.

Passenger car; $\alpha = 6.6$, $\beta = 0.12$

Truck WB 50; $\alpha = 1.2$, $\beta = 0.02$

Examples for Determining Track Clearance Green Time

Example 1: Figure 7 shows the queue consisting of one truck and multiple cars. Table 2 (page 29) shows that within 236 feet, it can fit one truck and seven cars assuming that one vehicle will be stopped on the tracks and the second on the pedestrian crosswalks. From the table, it can be concluded that the start-up time is 12.3 seconds and the travel time is 21.3 seconds, which results in a track clearance green time of 34.0 seconds.

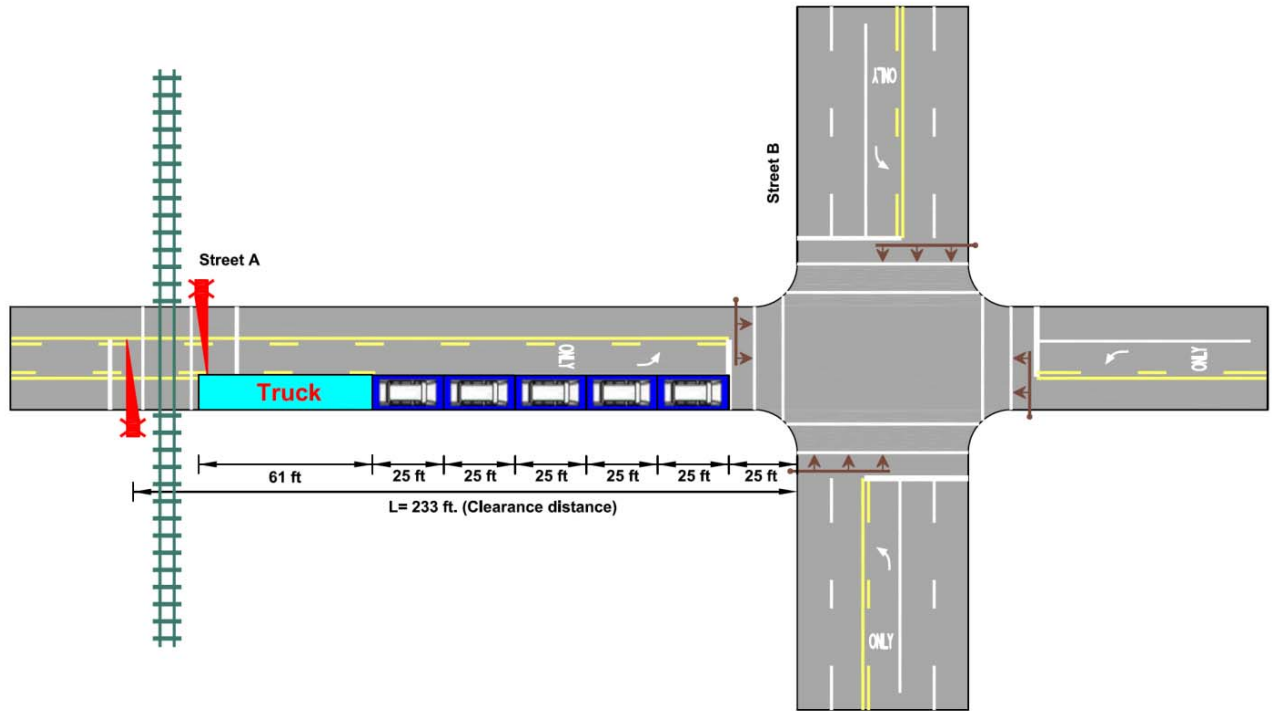

Figure 7. Example 1 for Determining Track Clearance Green Time (One Truck in the Queue)

Example 2: Figure 8 shows a queue consisting of two trucks and multiple cars. The clearance distance is 233 feet which is not shown in Table 3 (page 30). Therefore, a higher clearance distance of 247 feet from the table is selected. Accordingly the track clearance green time is 36.0 seconds.

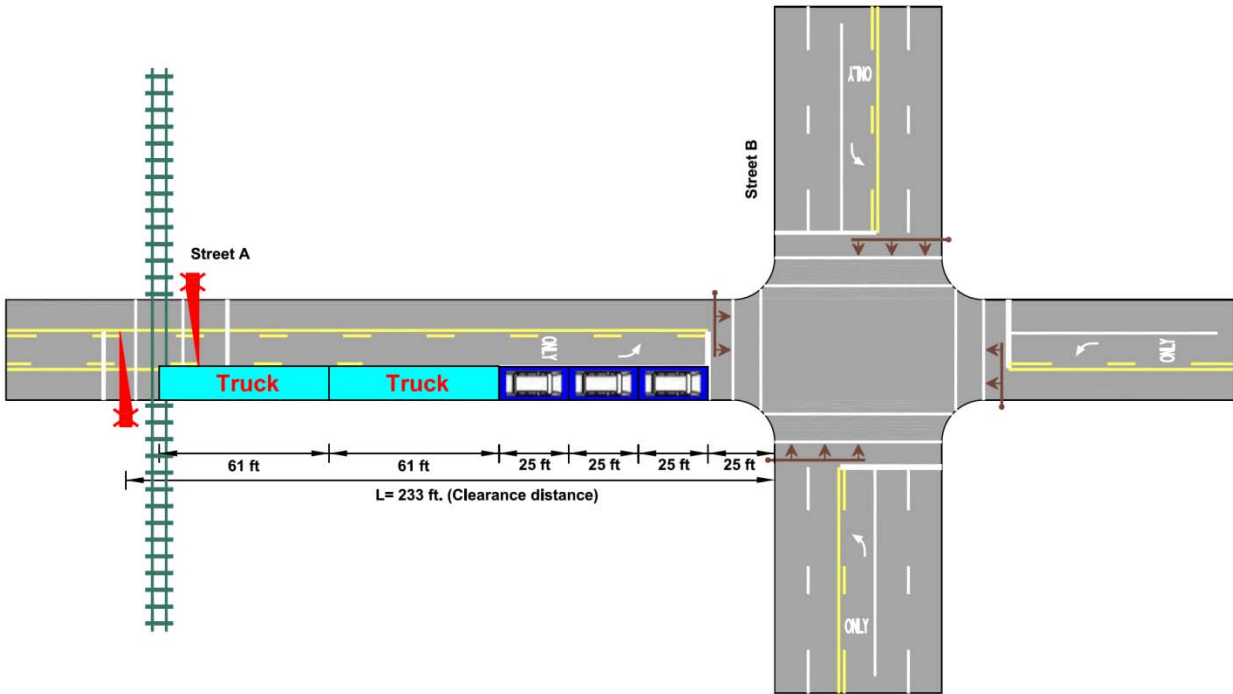

Figure 8. Example 2 for Determining Track Clearance Green Time (Two Trucks in the Queue)

Track Pedestrian Clearance Interval

The pedestrian clearance interval is usually set to zero.

Yellow and All Red Clearance Intervals

Yellow and all red clearance intervals follow the track clearance green interval. The existing values for clearance intervals along the track clearance direction should be used during this phase.

Dwell Phase

Dwell/holding phase consists of only that phase/phases of the normal operation mode which can be allowed during the period when the railroad preemption warning devices are active. During this phase, the traffic signal indications should be such that it will prevent vehicles from entering or turning towards the tracks. To restrict turning movements towards the tracks, changeable message indications (shown in Figure 9) for 'No Right/Left Turn towards the Tracks' or left and right turn signal heads can be used.

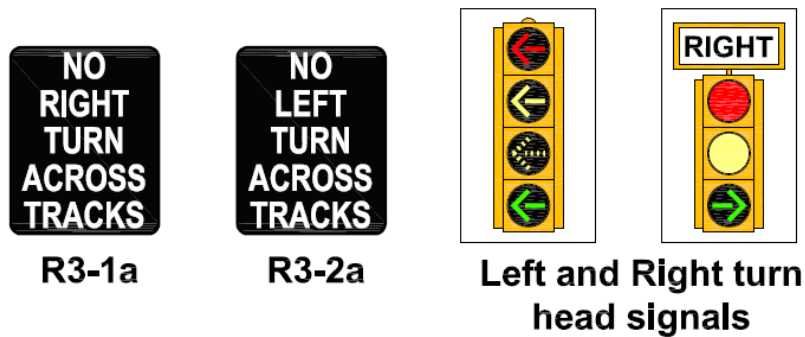

Figure 9. Changeable Message Sign and Head Signals to Restrict Turning Movements

The guidelines provided below should be followed during the dwell phase:

- Where railroad tracks are located at the middle of an intersection, all red should be indicated for all directions.
- Flashing yellow and flashing red should be substituted by green for the allowable movements during the preemption mode.
- A minimum green time of 10 seconds should be provided.
- During this and returning to the normal operation mode, any yellow and red clearance interval that follows should not be shortened or omitted as per MUTCD (5).
- If during this phase the street parallel to tracks is operational, yellow and all red along that direction should be used when returning back to the normal operation.
- If there are multiple phases, the maximum clearance interval (yellow and all red) among all allowable movements/phases should be used before returning back to the normal operation.

Exit Phase

The return to normal operations starts after the railroad preemption warning devices are deactivated. The common practice is to return the green phase to the approach crossing the tracks, but it is recommended to give priority to approaches that are expected to have longer queues.

IV. PROPOSED GUIDELINES FOR DETERMINING CLEARANCE DISTANCE

The clearance distance is utilized in the calculation of the track clearance green time. It represents the length of the critical queue that is expected to occur at any moment of the day along the railroad crossing approach. Accordingly, the critical queue can be along the exclusive left-turn lane, the through lane or the shared movement lanes. The clearance distance is a function of many factors related to the geometry of the railroad crossing approach and the type of traffic control devices. Determining the clearance distance focuses more on the safety of the automobile traffic because train-vehicle crashes are severe. Templates were developed to cover the different configurations of highway-railroad grade crossings on which the clearance distance was identified by considering the worst case scenario. The main factors used in generating the templates are:

- Presence/absence of a gate
- Existence of pre-signals
- Lane configurations
- Type of left-turn phase (permissive only, permissive – protected, protected only) where present
- Type of railroad crossing (simple, diagonal or middle of the intersection)

Gate and Pre-Signal Present

When gates and pre-signals are present, it is expected that there will not be any queue after the pre-signal; however, driver behavior cannot be predicted, so the worst scenario is when a driver runs the red light of the pre-signal and stops on or near the tracks. There is also the possibility that the preemption call is initiated while the left turning traffic is yielding to opposing traffic. Those concerns were clarified by developing three types of the templates based on the expected geometry of the railroad crossing approach.

- Case 1: Two-Lane Road
- Case 2: Four-Lane Road (left turn is shared with through movement)
- Case 3: Roads with an Exclusive Left-Turn Lane

Case 1: Two-Lane Road

This is where the railroad crossing exists and there is one lane in each direction, which means that the through, left and right movements are shared (no storage lane are provided for left or right movements at the intersection) and have permissible turning movements. In this case if the preemption is called and the first vehicle in the queue is turning left, then it has to yield to the opposing traffic, which results in blocking the entire movement. This may not cause a safety problem if the queue does not extend into the tracks (Figure 10) but can cause a safety concern if the queue extends to the tracks (Figure 11). In order to avoid this, a doghouse signal (i.e., signal head with ball and arrow) display should be installed for the approach crossing the tracks, so that the left turning traffic will have protected movement during the track clearance phase.

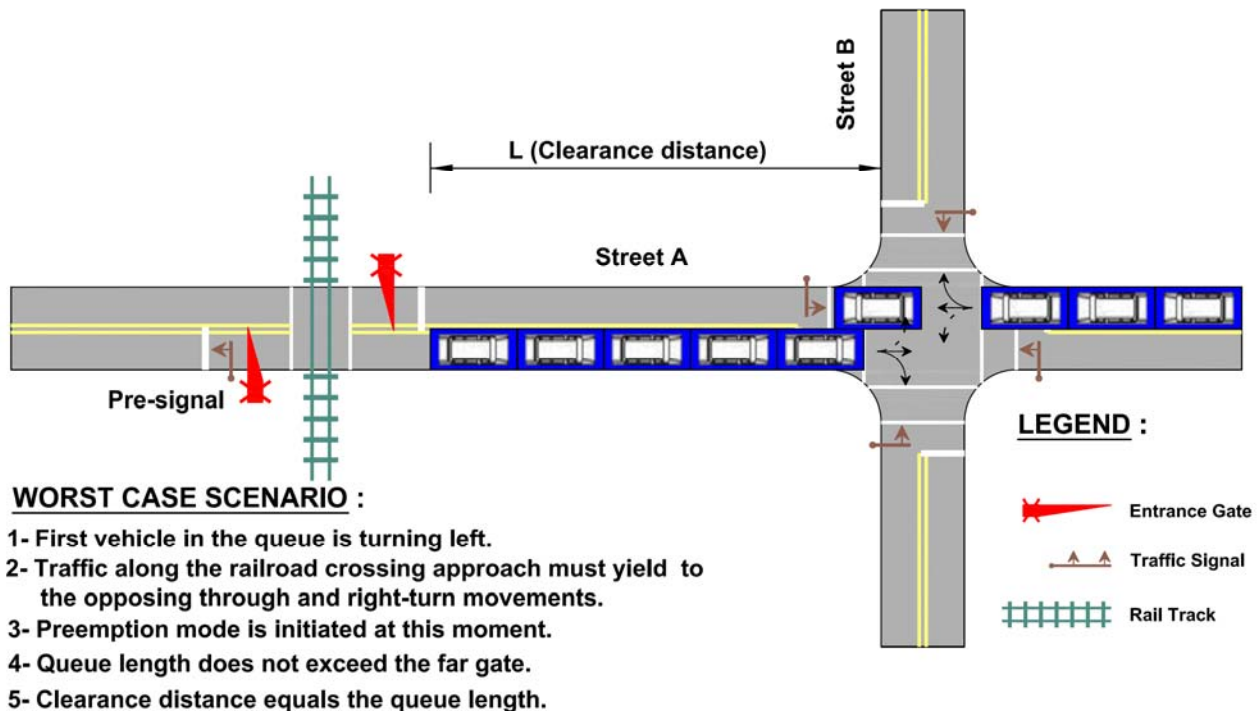
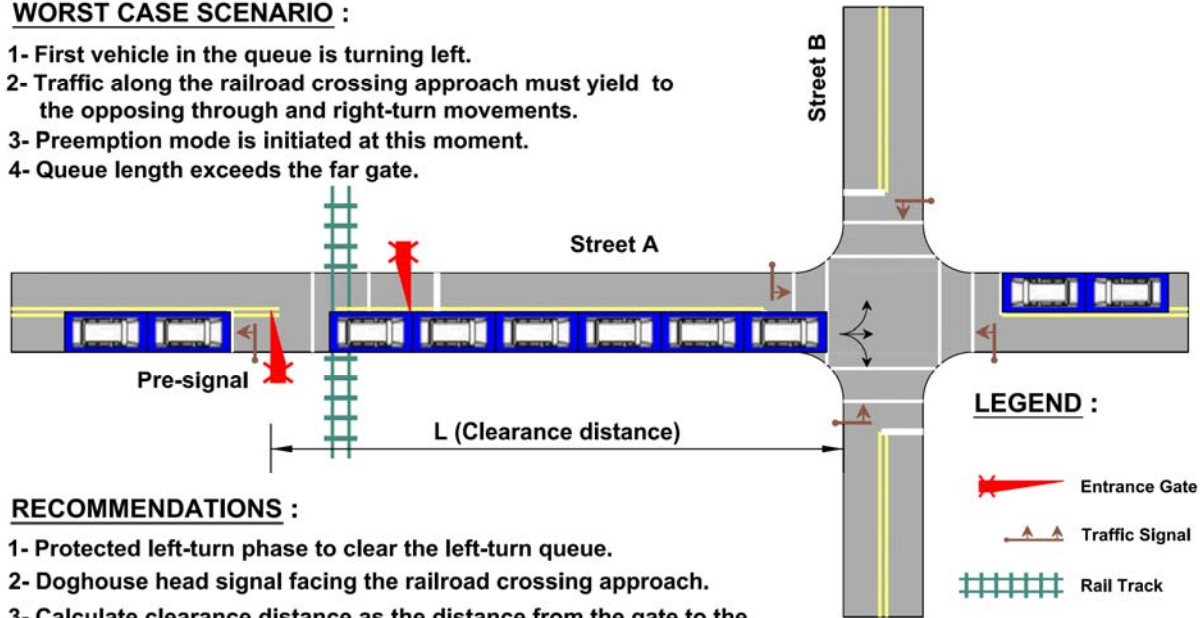

Figure 10. Clearance Distance on a Two-Lane Roadway When Queue is Not Extending Beyond the Tracks (Gate and Pre-Signal Present)

WORST CASE SCENARIO :

- 1- First vehicle in the queue is turning left.
- 2- Traffic along the railroad crossing approach must yield to the opposing through and right-turn movements.
- 3- Preemption mode is initiated at this moment.
- 4- Queue length exceeds the far gate.



RECOMMENDATIONS :

- 1- Protected left-turn phase to clear the left-turn queue.
- 2- Doghouse head signal facing the railroad crossing approach.
- 3- Calculate clearance distance as the distance from the gate to the edge of the pavement.

Figure 11. Clearance Distance on a Two-Lane Roadway When Queue is Extending Beyond the Tracks (Gate and Pre-Signal Present)

In the first case, when the queue does not reach the tracks (Figure 10), the queue length should be utilized for determining track clearance time. In the second case where the queue extends beyond the pre-signal (Figure 11), clearance distance should be the distance between the **far gate and the edge of the road**.

Case 2: Four-Lane Road (Left turn is shared with through movement)

Another configuration is where railroad tracks are crossing a four-lane road (two in each direction), the right and left turning movements are shared with through lanes and the traffic signal has a permissive left-turn phasing design as shown in Figure 12. The critical lane is the shared through and left turning lane because if the first vehicle in the queue is turning left, then it has to yield to opposing traffic which results in the formation of a queue. The queue length in the 'left turn shared lane' should be utilized for determining the track clearance time. If the queue length extends beyond the tracks, the clearance distance should be considered from **the far gate to the edge** of the road (Figure 13). A doghouse or a left-turn signal head should be installed to provide a protected phase for the left turning movement during the track clearance phase.

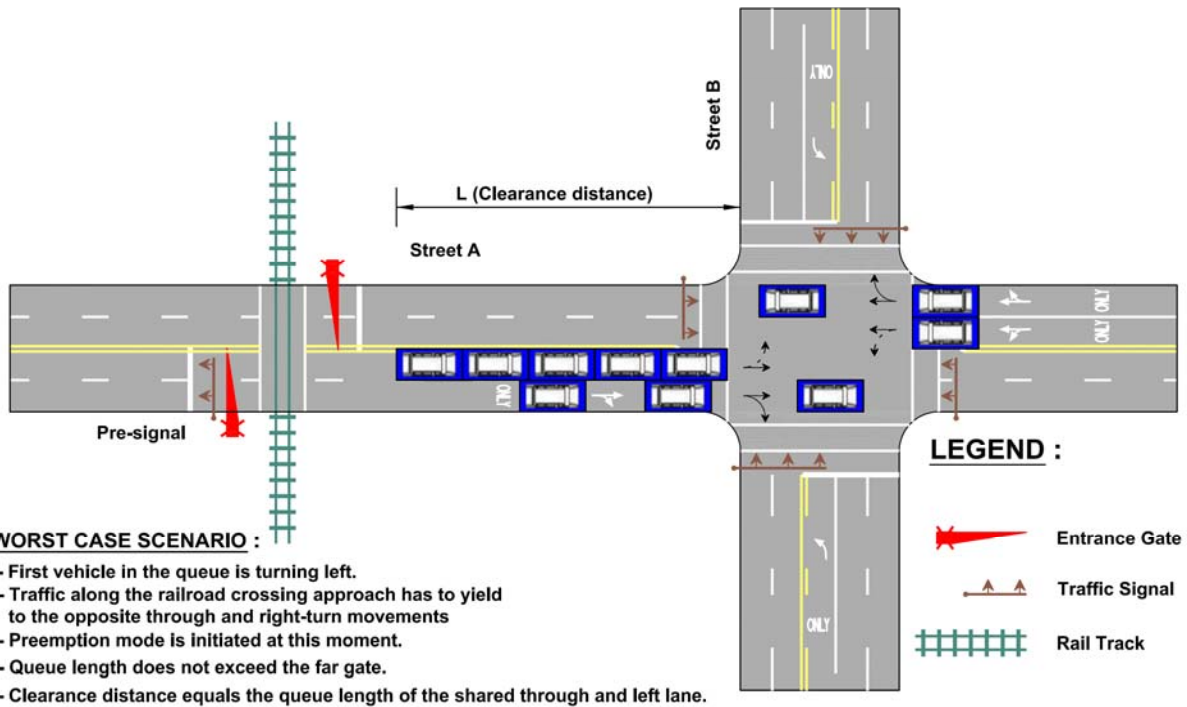

Figure 12. Clearance Distance on a Four-Lane Roadway When Queue is Not Extending Beyond the Tracks (Gate and Pre-Signal Present)

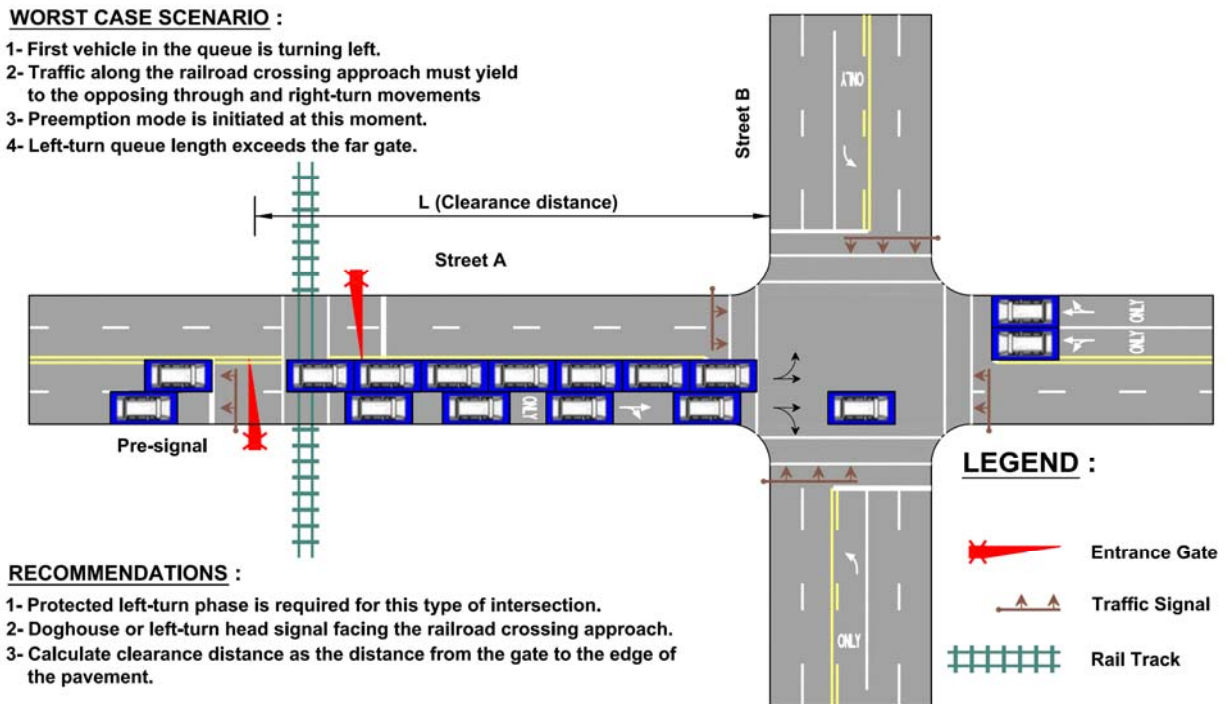

Figure 13. Clearance Distance on a Four-Lane Roadway When Queue is Extending Beyond the Tracks (Gate and Pre-Signal Present)

Case 3: Roads with Exclusive Left-Turn Lane

This is similar to the four-lane road where the critical queue is expected along the left-turning lane. Two cases should be considered for this since the roadway geometry depends on the magnitude of the left turning queue and available clear storage distance (measured from the stop bar to 6 feet from the nearest track edge to the intersection):

- If the clear storage distance is more than the left turning queue length (Figure 14), then there is no need for a protected left-turn phase during the track clearance phase.
- If the clear storage distance is less than the left turning queue length (Figure 15), then a protected left-turn phase should be provided during the track clearance phase by installing a left-turn signal head facing the left lane.

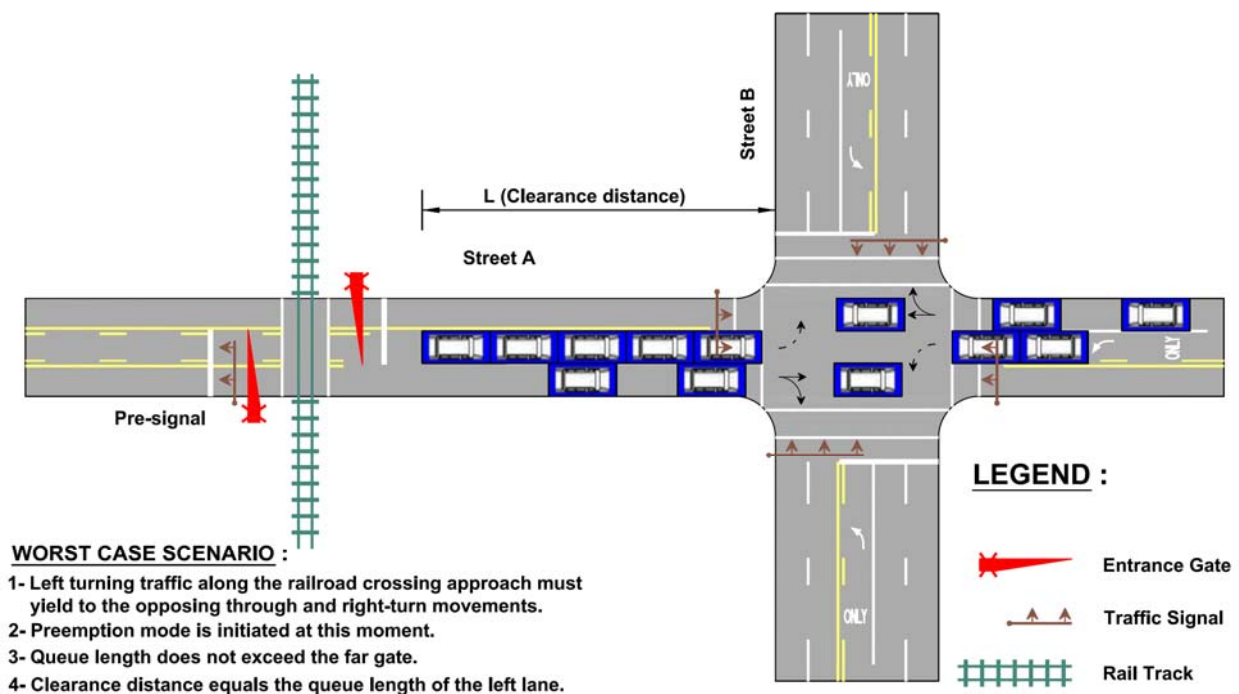
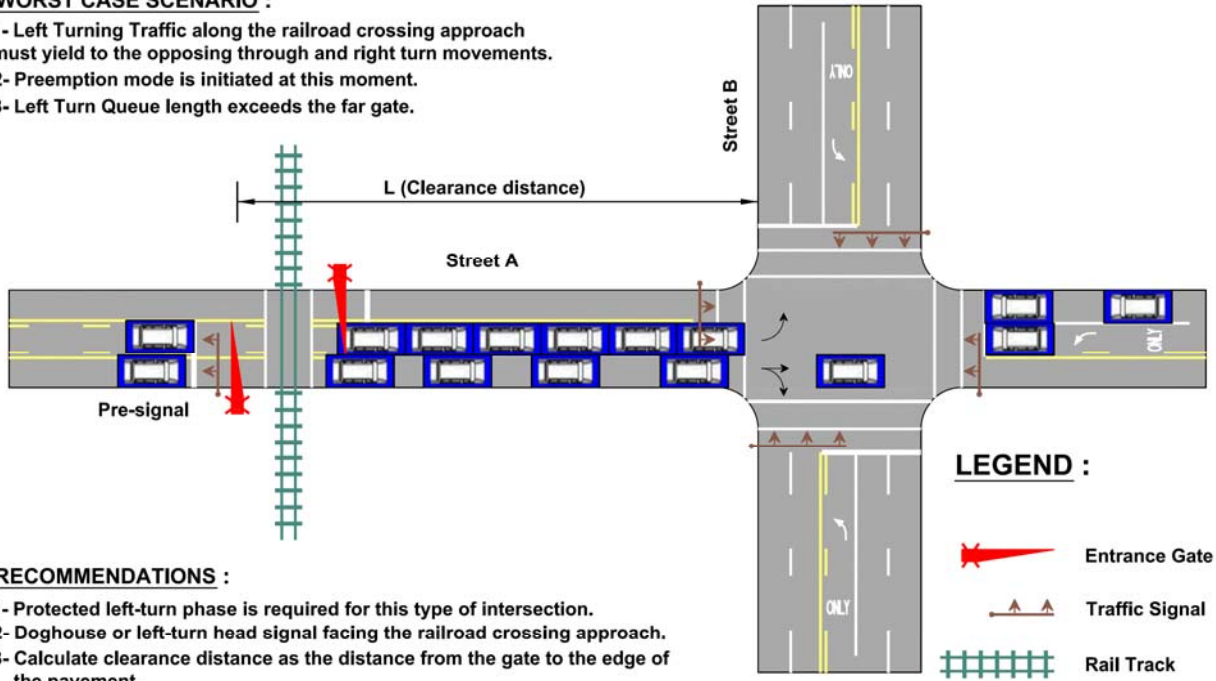

Figure 14. Clearance Distance on a Roadway with an Exclusive Left-Turn Lane When Queue is Not Extending Beyond the Tracks (Gate and Pre-Signal Present)

WORST CASE SCENARIO :

- 1- Left Turning Traffic along the railroad crossing approach must yield to the opposing through and right turn movements.
- 2- Preemption mode is initiated at this moment.
- 3- Left Turn Queue length exceeds the far gate.



RECOMMENDATIONS :

- 1- Protected left-turn phase is required for this type of intersection.
- 2- Doghouse or left-turn head signal facing the railroad crossing approach.
- 3- Calculate clearance distance as the distance from the gate to the edge of the pavement.

Figure 15. Clearance Distance on a Roadway with an Exclusive Left-Turn Lane When Queue is Extending Beyond the Tracks (Gate and Pre-Signal Present)

Gated Railroad Crossings Without Pre-Signal

If a gate is present without a pre-signal, the distance that should be considered to determine the track clearance time is minimum of:

- Clearance distance
- Maximum 95th percentile queue length (among all the lanes)

Possible worst case scenarios that can occur are as follows.

Case 1: Two-Lane Road

If it is a two by two lane intersection with a two phase signal design with no pre-signal, the two phase signal does not cause any problems during preemption mode, if the 95th percentile queue length does not exceed the available clear distance from the tracks. However, if the queue

extends beyond the tracks, the queue may not dissipate during the track clearance interval if the first vehicle in the queue turning left, as the turning vehicle yields to opposing traffic.

In order to ensure that the queue is cleared with one lane in each direction where the through, left and right movements are shared (no exclusive turn lane are provided for left or right movements at the intersection) may cause queue build-up. This may not cause a safety problem if the queue does not extend into the tracks (Figure 16), however can cause a serious safety issue if the queue extends to or beyond the tracks (Figure 17). In order to avoid this, a doghouse signal head (i.e., signal head with ball and arrow) should be installed for the approach crossing the tracks so that the left turning traffic may not block the queue behind.

When the queue does not reach the tracks (Figure 16), the queue length should be utilized for determining track clearance time. Where the queue extends to the tracks (Figure 17), clearance distance should be the distance from the far gate to the edge of the road.

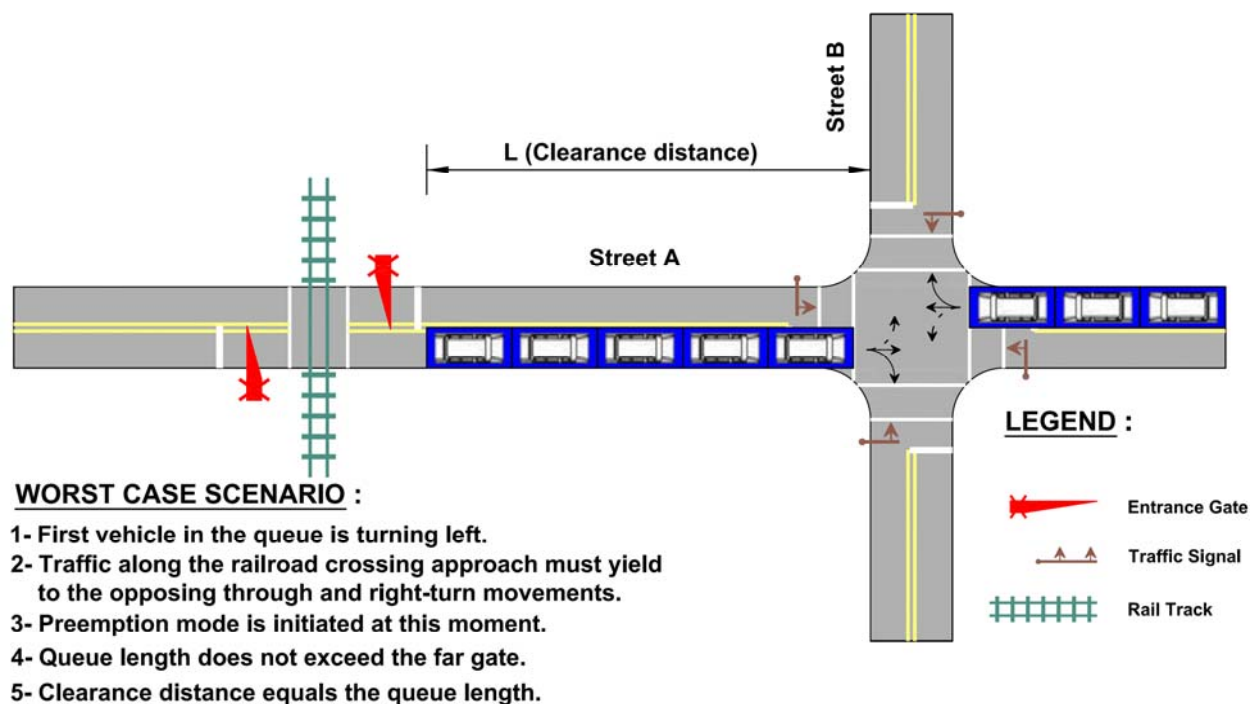

Figure 16. Clearance Distance on a Two-Lane Roadway When Queue is Not Extending Beyond the Tracks (Gate Present with a Pre-Signal)

WORST CASE SCENARIO :

- 1- First vehicle in the queue is turning left.
- 2- Traffic along the railroad crossing approach must yield to the opposing through and right-turn movements.
- 3- Preemption mode is initiated at this moment.
- 4- Queue length exceeds the far gate.

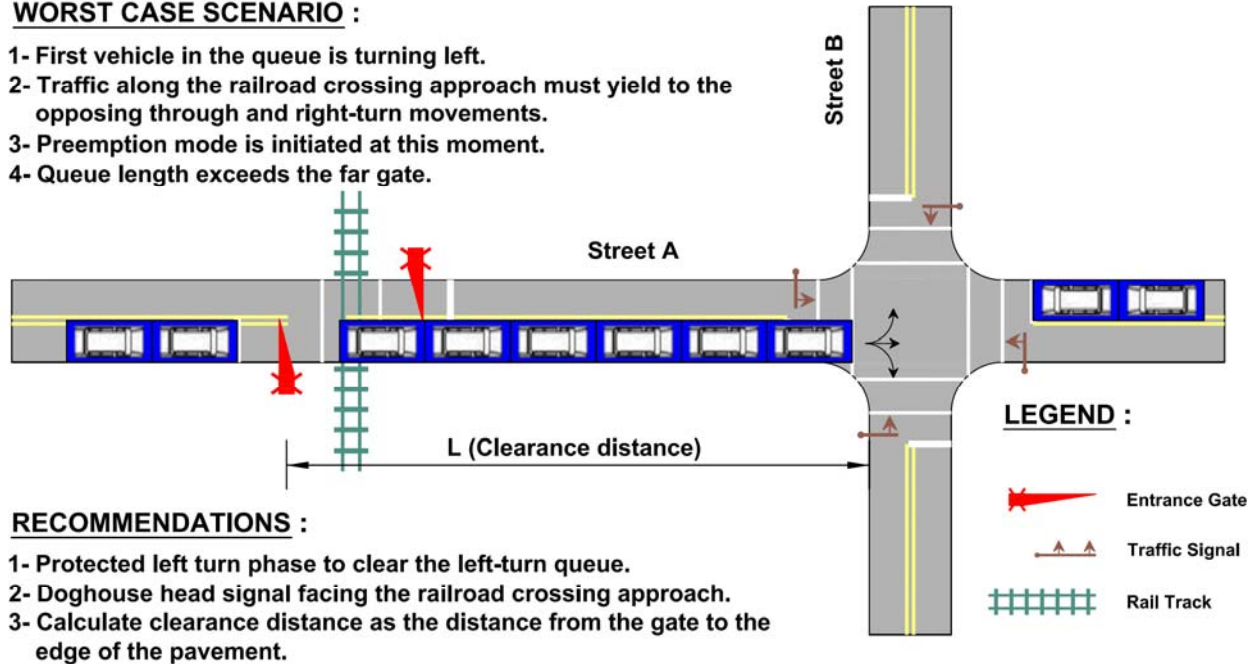

Figure 17. Clearance Distance on a Two-Lane Roadway When Queue is Extending Beyond the Tracks (Gate Present Without a Pre-Signal)

Case 2: Four-Lane Road

There are two scenarios for a four-lane road where the vehicles are queued within the clear storage zone, or they encroach on the train safety envelope. Shown in Figure 18, it is necessary to clear the 95th percentile queue during the track clearance phase in order to avoid having vehicles stuck between the railroad crossing and the intersection during the holding phase. Figure 19, all the vehicles queued between the far gate and the intersection have to be cleared during the track clearance phase. A protected left-turn phase is required to ensure clearing the vehicles turning left. A doghouse signal head should be installed facing the railroad crossing approach.

WORST CASE SCENARIO :

- 1- Preemption mode is initiated when the traffic along Street B has green light.
- 2- Left-turn queue can not be cleared with permissive left turn phase because yielding to the opposing traffic is required.
- 3- Drivers turning left can not recognize having the priority for clearing the track without the presence of left-turn green arrow.

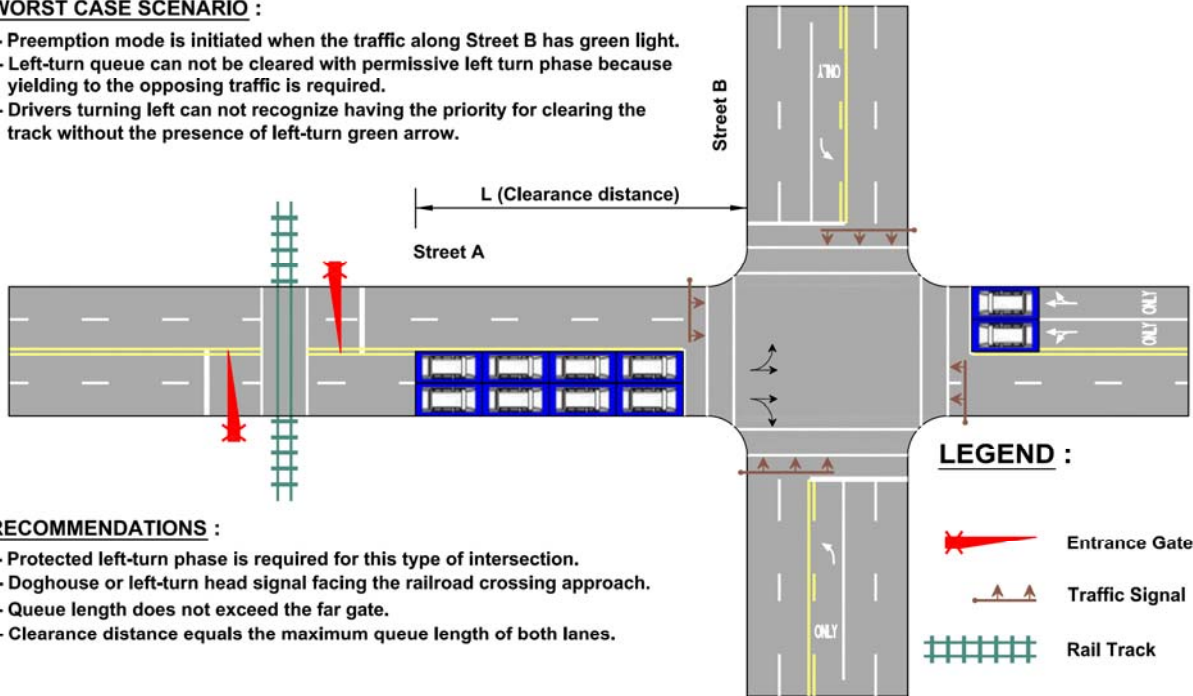

RECOMMENDATIONS :

- 1- Protected left-turn phase is required for this type of intersection.
- 2- Doghouse or left-turn head signal facing the railroad crossing approach.
- 3- Queue length does not exceed the far gate.
- 4- Clearance distance equals the maximum queue length of both lanes.

Figure 18. Clearance Distance on a Four-Lane Roadway When Queue is Not Extending Beyond the Tracks (Gate Present Without a Pre-Signal)

WORST CASE SCENARIO :

- 1- Preemption mode is initiated when the traffic along Street B has green light.
- 2- Left-turn queue can not be cleared with permissive left turn phase because yielding to the opposing traffic is required.
- 3- Drivers turning left can not recognize having the priority for clearing the track without the presence of left turn green arrow.

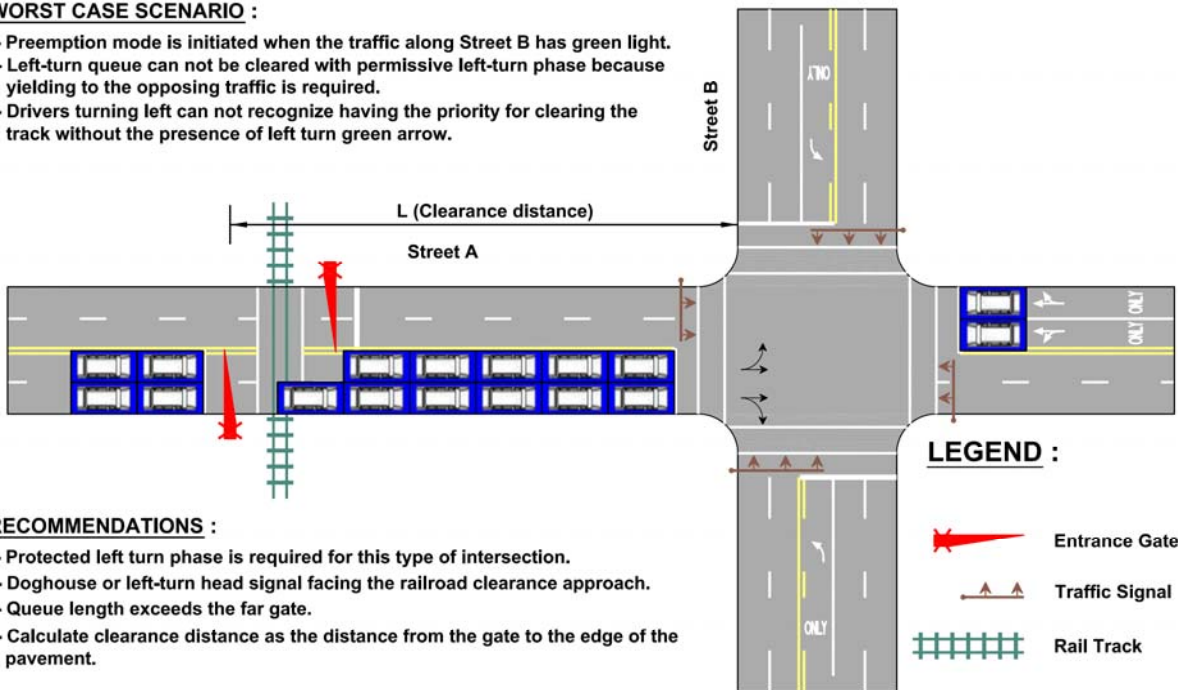

RECOMMENDATIONS :

- 1- Protected left turn phase is required for this type of intersection.
- 2- Doghouse or left-turn head signal facing the railroad clearance approach.
- 3- Queue length exceeds the far gate.
- 4- Calculate clearance distance as the distance from the gate to the edge of the pavement.

Figure 19. Clearance Distance on a Four-Lane Roadway When Queue is Extending Beyond the Tracks (Gate Present Without a Pre-Signal)

Case 3: Roadway with an Exclusive Left-Turn Lane

The queue length may or may not extend beyond the gate as shown in Figures 20 and 21. When the queue length is within the clear storage zone, it is necessary to clear the 95th percentile queue pertaining to the critical lane. A protected left-turn phase is necessary when the estimated left-turn queue exceeds the available storage space.

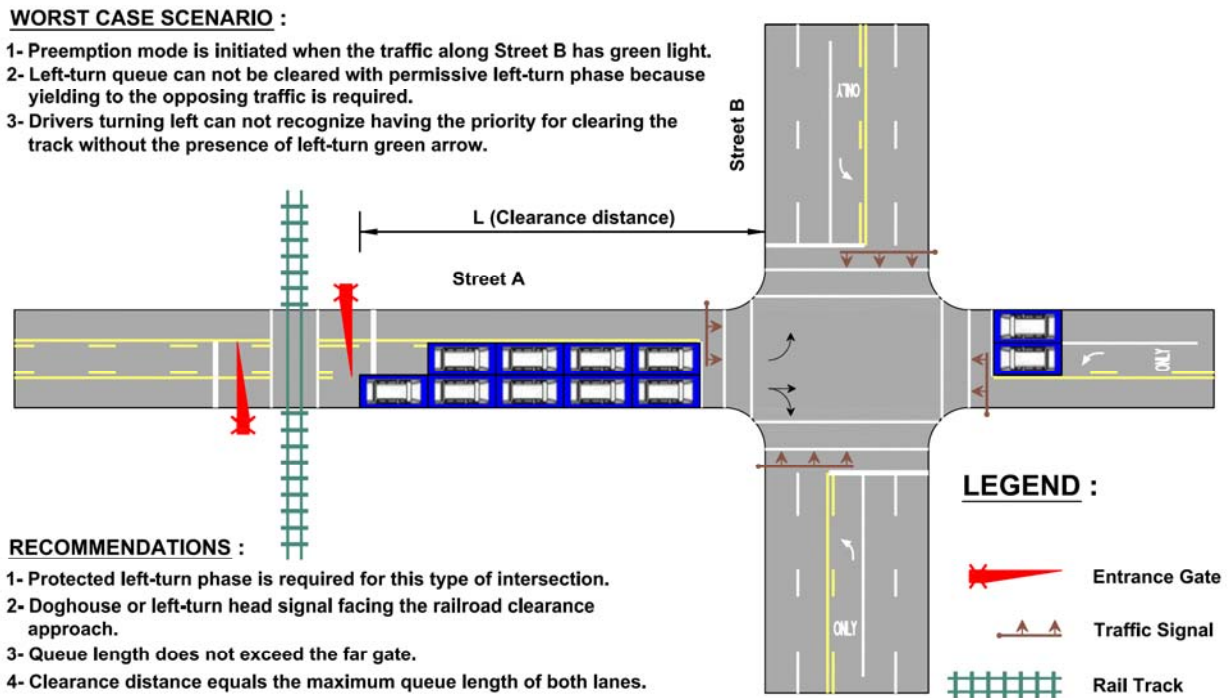
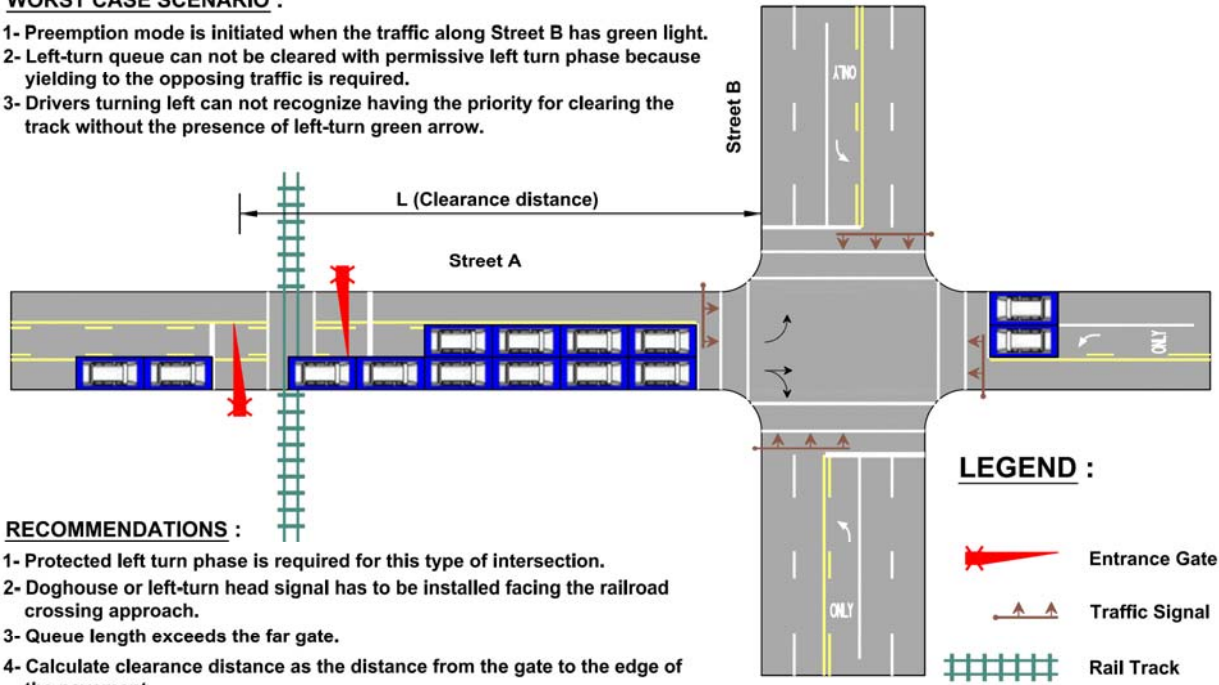

Figure 20. Clearance Distance on a Roadway with an Exclusive Left-Turn Lane When Queue is Not Extending Beyond the Tracks (Gate Present Without a Pre-Signal)

WORST CASE SCENARIO :

- 1- Preemption mode is initiated when the traffic along Street B has green light.
- 2- Left-turn queue can not be cleared with permissive left turn phase because yielding to the opposing traffic is required.
- 3- Drivers turning left can not recognize having the priority for clearing the track without the presence of left-turn green arrow.



RECOMMENDATIONS :

- 1- Protected left turn phase is required for this type of intersection.
- 2- Doghouse or left-turn head signal has to be installed facing the railroad crossing approach.
- 3- Queue length exceeds the far gate.
- 4- Calculate clearance distance as the distance from the gate to the edge of the pavement.

Figure 21. Clearance Distance on a Roadway with an Exclusive Left-Turn Lane When Queue is Extending Beyond the Tracks

Railroad Crossing in the Vicinity of a Boulevard

For boulevards where only through lanes are present with no left-turn lane (Figure 22), the worst case scenario is considered to be the one when the traffic along the parallel approach to the tracks is moving. In this case if the preemption is called, there should be no vehicle queue on the other side. However, to assure safety, a 10-15 second track clearance time should be provided, if a vehicle runs the red light and gets stuck on the tracks, and needs to be cleared before the train arrives.

If there is no pre-signal, the clearance distance will be minimum of (a) 95th percentile queue length among all the lanes (b) the distance between the far side gate and the edge of the near side pavement.

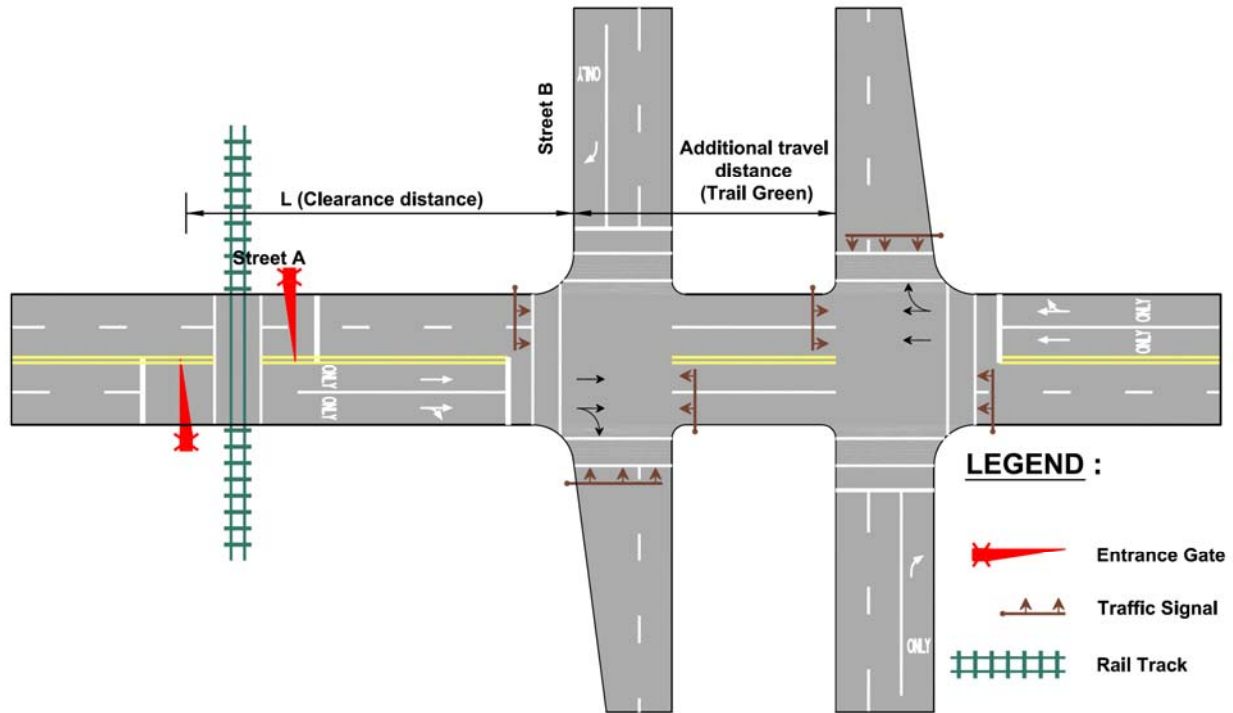

Figure 22. Clearance Distance When a Railroad Crossing is Located Near a Signalized Boulevard Intersection

Diagonal Railroad Crossings

At some railroad crossing locations, the railroad tracks may cross two approaches of an intersection which creates a critical situation regarding track clearance requirements, especially when the distance from the crossing to both lefts of the intersection are within 200 feet (Figure 23). Two track clearance intervals are required in order to ensure that no vehicles are trapped on the tracks prior to the arrival of the train. Lowering the gates closest to the tracks which control the vehicles leaving the intersection, should be delayed to clear all vehicles turning toward the railroad crossings during the track clearance intervals. As a consequence, the calculation of the minimum warning time is controlled by the time necessary for the last vehicle to clear the first railroad crossing approach, to turn to the intersection toward the second railroad crossing, and then clear it. It is expected that the minimum warning time may exceed 60 seconds which conflicts with Michigan Law (RAILROAD CODE OF 1993 (EXCERPT) Act 354 of 1993). Solving this can be achieved by:

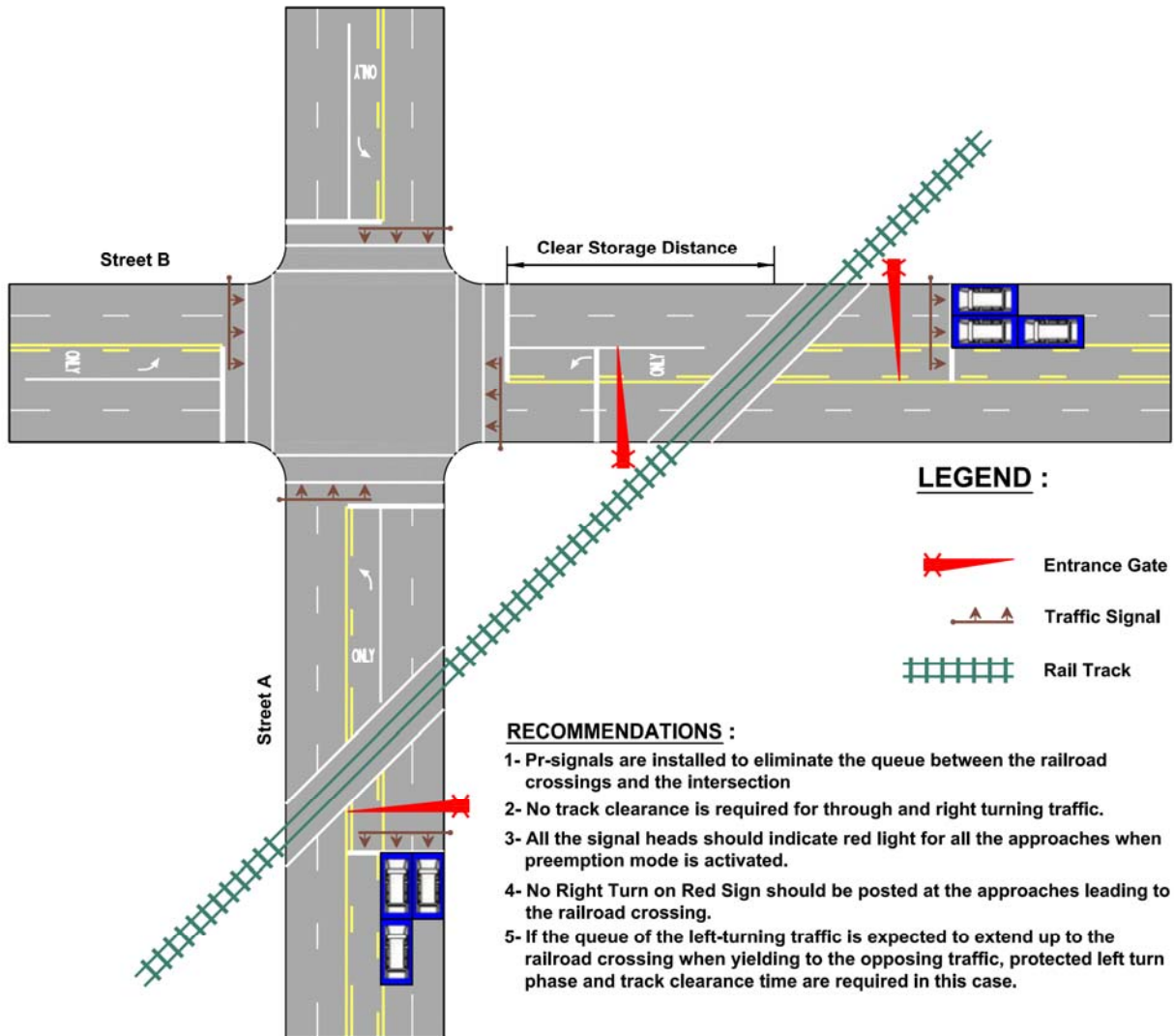

Figure 23. Skewed Railroad Crossing Two Approaches Near a Signalized Intersection

- Utilizing queue prevention strategies such as pre-signals or queue cutter signals in order to ensure that there will not be any queued vehicles between the crossing and the intersection. According to ITE recommendations (36) and after an engineering study is completed, pre-signals can be installed at railroad crossing approaches to have a clear storage distance less than 120 feet. When the clear storage is greater than 120 feet, the pre-signal should be considered as “queue-cutter” signal. This has an adverse effect on the delay during normal operation mode because during each cycle, two trail green periods are required to clear the queue between the pre-signal and the intersection. When

preemption mode is initiated, there is no need for track clearance phases after termination of the current phase due to the absence of vehicles queued between the pre-signal and the intersection. The engineer, however, may provide a minimum track clearance green of 15 seconds to clear the vehicles that may have violated the red light. If the left-turn traffic volumes generate a queue length extending beyond the railroad crossing, when yielding to the opposing through and right turning movements, a protected left-turn phase and track clearance green time will be necessary.

- Advance preemption time can be utilized to terminate the active phase and enter into track clearance for one of the railroad crossings before the railroad warning devices are turned on. After that, the warning time is used to cover the remaining track clearance of the vehicles as well as provide a separation time before the arrival of the train. This alternative is presented in Figure 24.

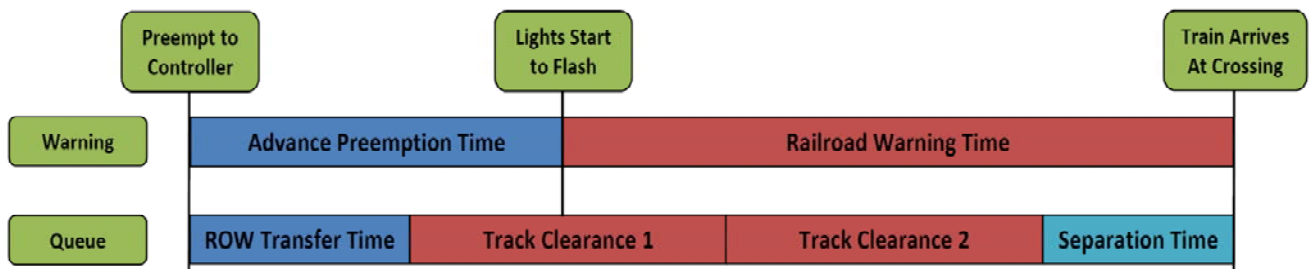

Figure 24. Advance Preemption Chart

- In case the queue study for a diagonal crossing concludes that during normal operation mode only one of the railroad crossing has a queue length exceeding the clear storage distance (the second approach has enough clear storage distance to fit the queue without encroaching on the tracks), track clearance green time is required for this approach only.

Railroad Crossings in the Middle of the Intersection

At some locations where the rail tracks cross in the middle of an intersection, as shown in Figure 25, no track clearance interval is required. The traffic signal shall indicate red for all approaches.

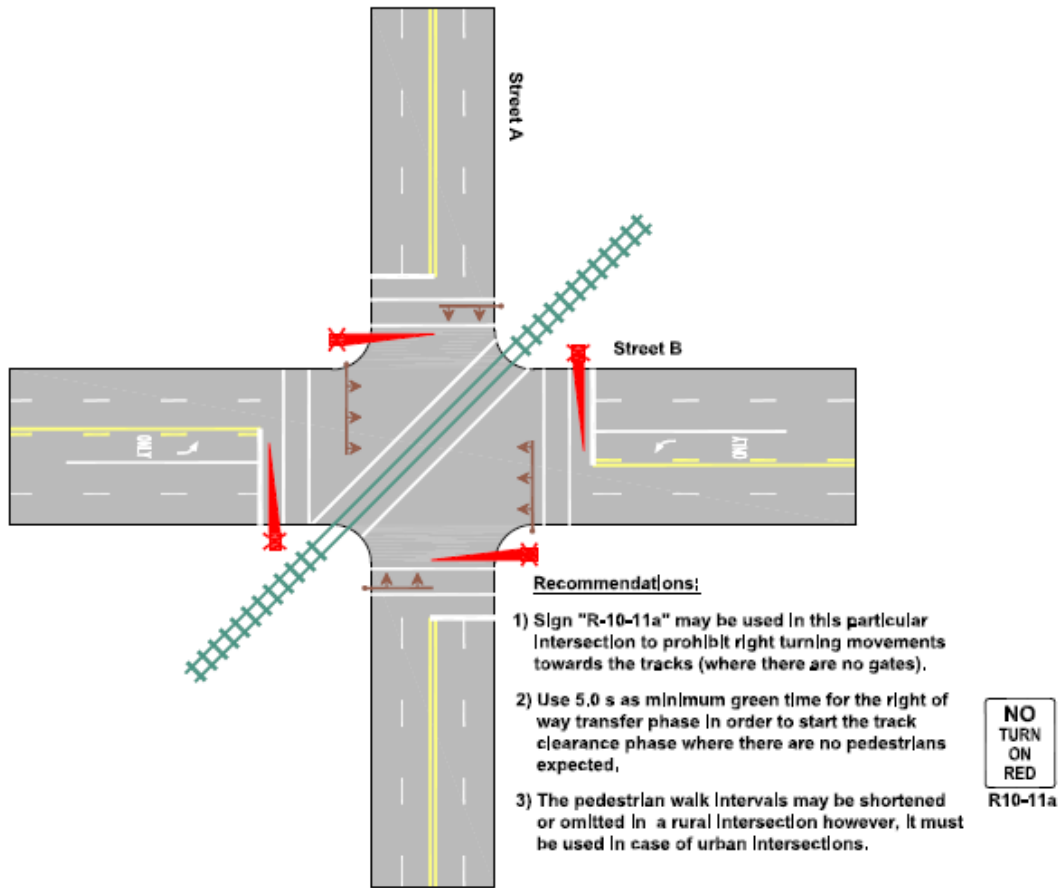

Figure 25. Railroad Crossing Through the Middle of a Normal Signalized Intersection

V. GUIDELINE FOR CALCULATING MINIMUM WARNING TIME

Many states use a minimum warning time of 20 seconds before the train arrives. However, the minimum required warning time should be determined on the basis of all the pedestrian and vehicular clearance interval requirements. The minimum required warning time should include the following

- Minimum right-of-way transfer time =Max[(Flashing Don't Walk Interval + All Red), (Min Green +yellow +All Red)]
- Minimum Track Clearance Time (clearing the minimum track clearance distance)
- Additional safety interval 4-8 seconds [*Marshall and Berg, (15)*]

Minimum track clearance distance, as defined in MUTCD, is measured from the gate/warning device/railroad stop line or 12 feet perpendicular to the centerline of the tracks, to 6 feet beyond the tracks measured perpendicular to the far track, either along the center or edge line of the road to get the longer distance (Figure 26). (*MUTCD Section 8A.01*)

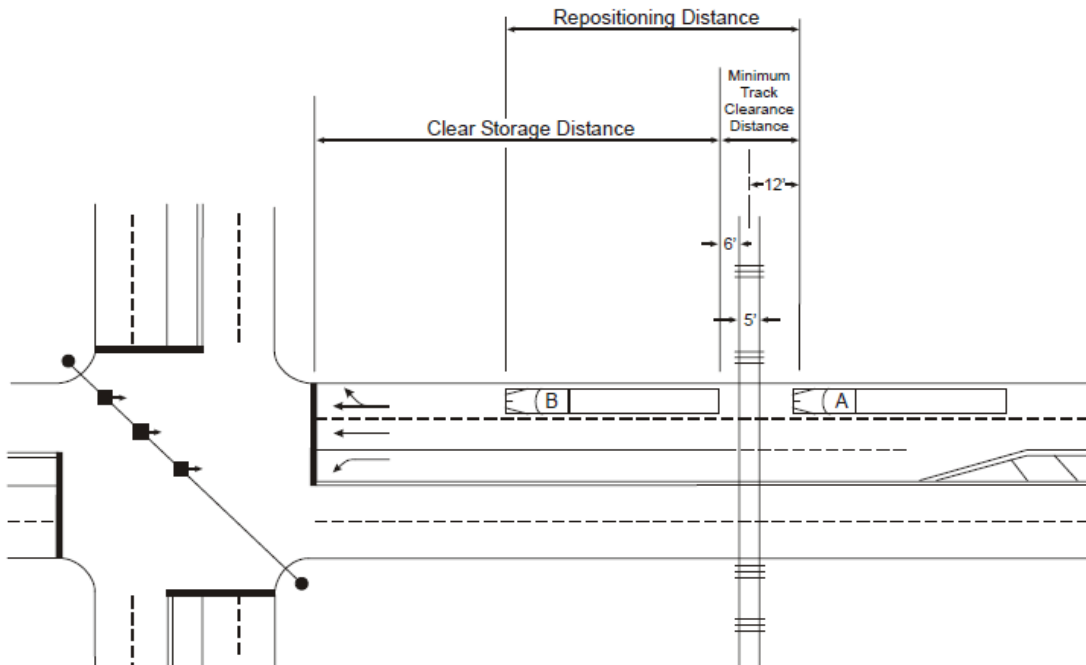

Figure 26. Minimum Track Clearance Distance (13)

A few examples are as follows:

Examples

1. Right-of-Way Transfer Intervals:
 - Minimum Green Time: 5.0 seconds
 - Pedestrian Clearance: 17.0 seconds
 - Yellow Interval: 3.6 seconds
 - Red Interval: 2.5 seconds
2. Track Clearance Intervals:
 - Minimum track clearance distance: 26 feet
 - Considering a WB-50 truck standing/trapped on the tracks (worst case)
 - Startup time for a WB-50 is 4 seconds
 - Travel time for a WB-50 to clear 50 feet is 9.5 seconds
3. Safety Interval of 4 to 8 seconds is recommended. An interval of 6 seconds is adopted.

Required warning time based on pedestrian clearance interval = Ped CI + Red Interval + Startup time + Travel Time + Safety Interval
Warning time = $17.0 + 2.5 + 4.0 + 9.5 + 6.0 = 39.0$ seconds

Required warning time without taking into consideration pedestrian clearance interval = Green Time + Yellow Interval + Red Interval + Startup time + Travel Time + Safety Interval =
 $5.0 + 3.6 + 2.5 + 4.0 + 9.5 + 6.0 = 30.6 \approx 31.0$ seconds

Therefore, use a warning time of 39 seconds.

Determination of Queue Length

Queue length can be determined by utilizing:

- ITE Guidelines
- Highway Capacity Manual
- Traffic Simulation using Synchro SimTraffic Software
- Direct Observation
- Using Nomograph

ITE Guidelines

The FHWA highway-railroad grade crossing handbook provides guidelines to determine queue lengths. It gives the following formulas for the queue length determination.

$$L = 2qr (1+p) 25; \text{ if } v/c < 0.9$$

Where;

L= length of queue (ft)

q=vehicle flow rate (veh/lane/sec)

r=effective red time (red +yellow) (sec)

p=proportion of heavy vehicles in traffic flow (as a decimal)

A parameter of 25 has been used in the formula to account for the effective length (i.e., actual length + headway b/w the cars) of a passenger car. The factor of 2 is used to account for random arrivals of traffic.

Effective time the crossing would be blocked by a train can be determined by the following formula:

$$r = 35 + (L/1.45S), \text{ where } L = \text{train length (ft)} \ \& \ S = \text{train speed (mph)}$$

In cases where the v/c ratio is between 0.90 and 1.0, the following equation applies:

$$L = 2qr (1+\Delta x) (1+p) (25)$$

If the v/c ratio exceeds 1.0 or the intersection is over saturated the guide recommends using Highway Capacity Manual analysis or traffic simulation models (e.g., SimTraffic) to determine the 95th percentile queue lengths (queues that will not be exceeded 95% of the time).

Highway Capacity Manual Procedure

The Highway Capacity Manual gives the average back-of-queue as the basic measure to calculate the 'percentile' back of queue. In order to determine the back-of-queue at signalized intersections, the manual gives the following basic equation:

$$Q = Q_1 + Q_2$$

Q= maximum distance in vehicles over which queue extends from stop line on average signal cycle (veh),

Q₁= first-term queued vehicles (veh), and

Q₂= second-term queued vehicles (veh)

The first term, Q₁ is the average back of queue, determined first by assuming a uniform arrival pattern and then adjusting for the effects of progression for a given lane group. The first term is calculated using the following equation:

$$Q_1 = PF_2 \frac{\left(\frac{V_L C}{3600}\right)\left(1-\frac{g}{C}\right)}{1-\left[\frac{\min(1.0, X_L)g}{C}\right]} \dots\dots\dots \text{(Highway Capacity Manual 2000)}$$

Where

Q₁= first-term queued vehicles (veh),

PF₂= adjustment factor for effects of progression,

V_L = lane group flow rate per lane (veh/hr.)

C = cycle length (s)

g = effective green time (s), and

X_L= ratio of flow rate to capacity (V_L/C_L ratio)

Q₁ represents the number of vehicles that arrive during the red phases and during the green phase until the queue has dissipated. The adjustment factor for the effects of progression is calculated by the following equation:

$$PF_2 = \frac{\left(1-\frac{R_p g}{C}\right)\left(1-\frac{V_L}{S_L}\right)}{\left(1-\frac{g}{C}\right)\left[1-R_p\left(\frac{V_L}{S_L}\right)\right]} \dots\dots\dots \text{(Highway Capacity Manual 2000)}$$

Where,

PF₂= adjustment factor for effects of progression

V_L = lane group flow rate per lane (veh/h)

S_L = lane group saturation flow rate per lane (veh/h)

g= effective green time (s)

C = cycle length (s), and

R_p = platoon ratio [P(C/g)]

The second term, Q_2 , is an incremental term associated with randomness of flow and overflow queues that may result because of temporary failures, which can occur even when demand is below capacity. This value can be an approximate cycle overflow queue when there is no initial queue at the start of the analysis period. Initial queue at the start of the analysis period is also accounted for in the second term, Q_2 . The equation shown below is used to compute the second term of the average back of queue.

$$Q_2 = 0.25 C_L T [(X_L - 1) + \sqrt{(X_L - 1)^2 + \frac{8k_B X_L}{C_L T} + \frac{16k_B Q_{bL}}{(C_L T)^2}}] \dots\dots\dots (39)$$

The second-term adjustment factor related to early arrivals is calculated using the following equation:

$$K_B = 0.12 l (S_L \frac{g}{3600})^{0.7} \dots\dots\dots \text{(pretimed signals)}$$

$$K_B = 0.101 l (S_L \frac{g}{3600})^{0.6} \dots\dots\dots \text{(actuated signals)}$$

Where

K_B = second-term adjustment factor related to early arrivals,

S_L = lane group saturation flow rate per lane (veh/h)

g = effective green time (s), and

l = upstream filtering factor for platoon arrivals

Traffic Simulation Procedure

The 95th percentile queue can be determined through traffic simulation using software such as SimTraffic. The inputs are the traffic volumes for the movements, the intersection geometry and the traffic signal timing and phasing. The software assumes by default that the percentage of heavy vehicles is 2.0 %. If this value is not correct, it can be revised. For the high volume roadways, the peak hour volume was assumed as 10% of the AADT.

Direct Observation

A more reliable and realistic approach is observing the queue lengths at the location during critical hours. Video cameras can be installed at the approaches of the intersection to record the traffic flow. The data can be extracted to determine the 95th percentile queue length.

Using Nomograph

The nomograph presented in the ITE Journal (40) can be utilized to estimate the 95th percentile queue for isolated intersections, assuming a random arrival of vehicles (Figure 27).

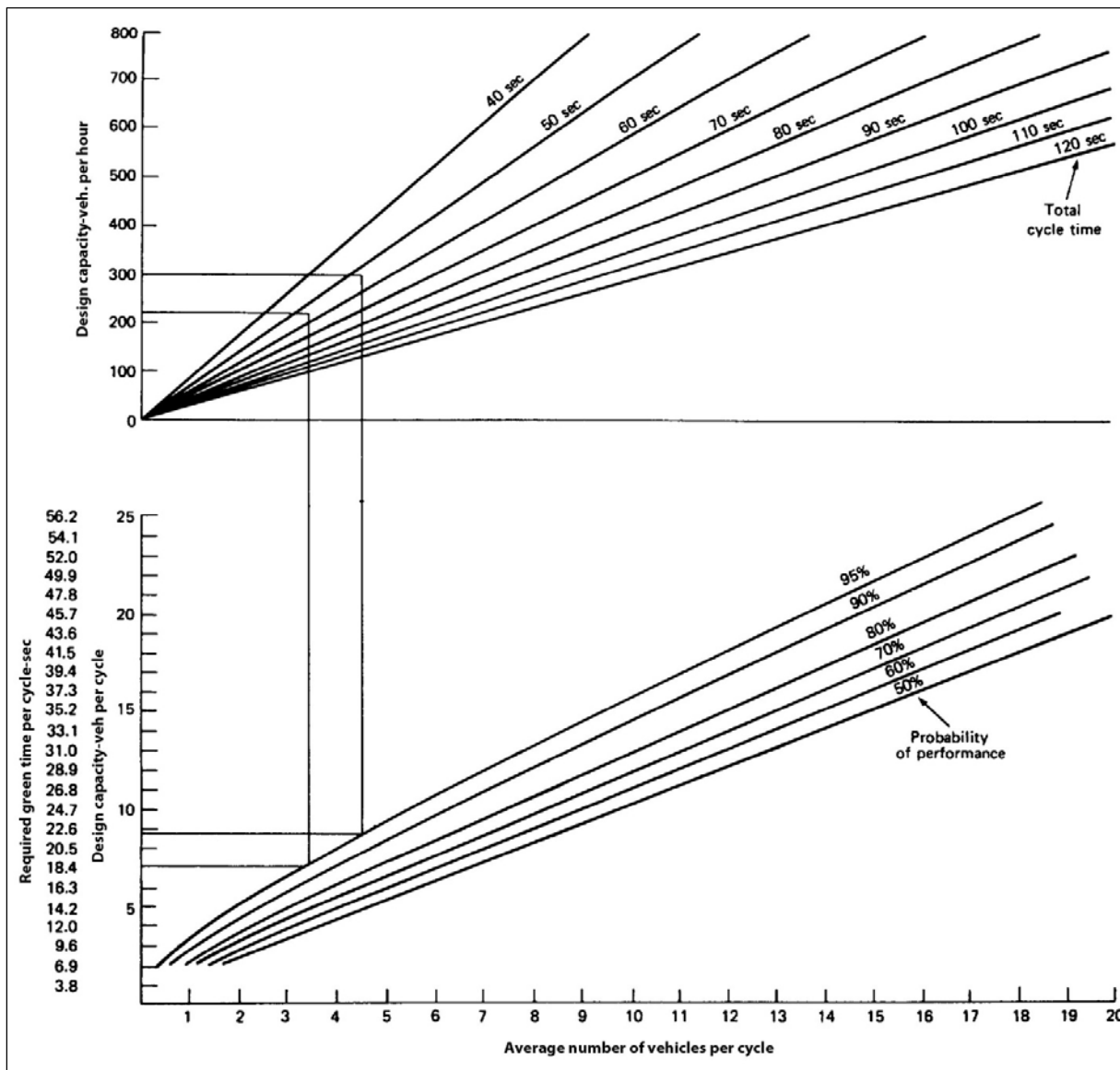

Figure 27. Cycle Capacity Probability Design Curves (40)

VI. ASSESSMENT OF EXISTING SIGNALIZED INTERSECTIONS WITH RAILROAD PREEMPTION

There are currently 178 railroad-roadway grade crossings that are interconnected with a nearby traffic signal in Michigan. Summarized site information for the 178 interconnected signalized intersections/railroad crossings are in Appendix B. An engineering study should be performed for the interconnected traffic signals to assess preemption signal timing plans based on the guidelines provided in this report. The engineering study should include the following steps:

- **Existing condition data for the critical approach** should be collected from various sources. The data consists of:
 - Critical approach ADT,
 - Traffic signal timing permit,
 - Number of lanes on critical approach,
 - Distance from the signalized intersection to 6-ft prior to the tracks on the critical approach (clear storage distance),
 - Distance from the signalized intersection to the far gate on the critical approach,
 - Whether a pre-signal exists, and
 - Whether pedestrian facilities exist at the signalized intersection
- The **right-of-way transfer time** should be calculated based on the following:
 - Minimum green time
 - Whether or not pedestrian clearance is required
 - Yellow and all-red clearance interval timings
- The estimated length of **queue for use in the track clearance green** calculation should include the determination of:
 - The 95th percentile queue length and vehicle composition (cars vs. trucks)
 - When the 95th percentile queue exceeded the clear storage distance, the design queue length was considered as equal to the distance from the intersection to the far gate.
 - If the 95th percentile queue is less than the clear storage distance, then the queue length is equal to the 95th percentile queue length.

- The **track clearance green time** should be determined based on the following:
 - Design queue length to be cleared
 - Acceleration characteristics of vehicles within the queue
 - Yellow and all-red clearance interval timings
- The **dwelling phase and return phase** lengths should be calculated for the following:
 - Allowable movements for dwell phase
 - Minimum dwell green
 - Return yellow and all-red clearance interval timings
 - Return phase
- The **minimum warning time** for the railroad crossing should be determined based on the greater of:
 - 20 second minimum allowable warning time or
 - Summation of the right-of-way transfer phase and the portion of the time necessary to clear the train envelope
- Additional improvements may be used as appropriate that include
 - Installation of illuminated “No Turn Across Tracks” signs
 - Installation of new traffic signals for certain left and right turn approaches
 - Adjustments/additions to turn phases

Preemption Design Templates

A set of templates were developed to assist with designing the preemption operation mode for interconnected signalized intersections. Seven templates were developed, each of which represented common geometric and railroad crossing configuration. These templates are in Appendix C. They include the following intersection/railroad crossing configurations:

- Template 1: Railroad crossing through the middle of a normal signalized intersection
- Template 2: Railroad crossing through the middle of a skewed signalized intersection
- Template 3: Railroad crossing near a signalized boulevard intersection
- Template 4: Skewed railroad crossing two approaches near a signalized intersection
- Template 5: Railroad crossing on a two-lane roadway near a signalized intersection
- Template 6: Railroad crossing near a signalized intersection with an exclusive left-turn lane on the critical approach
- Template 7: Railroad crossing on a four-lane roadway near a signalized intersection

VII. USING THE RAILROAD PREEMPTION ASSESSMENT TOOL

Introduction

The Wayne State University – Transportation Research Group as a part of this project has developed a “Railroad Preemption Assessment Tool” to help evaluate the need for preemption at a signalized intersection that is near railroad tracks. The program utilizes a series of site-specific data to determine:

- 1) the 95th percentile queue for the traffic signal located in the close proximity of a railroad crossing,
 - 2) whether or not a preemption is needed,
- and, 3) the minimum track clearance green time if preemption is needed.

The software can be accessed through the web link <https://docs.wayne.edu/5012e76769d85/>

It provides a brief instruction on how to run the “Railroad Preemption Assessment Tool”, and includes opening the file, properly filling in the forms, viewing and interpreting the results.

Running the Program

1. When the document is initially opened, the user will immediately be prompted to “Enable Content” by Excel. **Select “Enable,”** allowing the file to run the program properly.
 - a. **Note:** If the user does not enable the content, the program cannot be run and the user will have to close the file and re-launch it to enable the content when the document opens.
2. The program will automatically appear (pop up) when the user enables the content.
3. If the user closes the program at any point in time and would like to reopen it, this can be achieved by selecting the appropriate button in the excel document and it will re-launch the program.

Entering Inputs

All input fields must be filled in for the program to yield results. Missing data will result in an error message when the “Click to view results” button is pressed. The input fields are described as follows.

Average Daily Traffic (ADT): The actual/estimated ADT for the roadway should be entered. This value may represent either one directional or two directional traffic. If a peak hour traffic volume is available for the critical approach direction, simply multiply the value by a factor of 10 to estimate the ADT in the critical direction. Please note: depending on the signal timing, excessively large traffic volumes may cause the physical capacity of the traffic signal to be exceeded, resulting in unreliable estimation of the 95th percentile queue length. Although the estimated 95th percentile queue is provided to the user, a cautionary note is displayed under such circumstances.

Commercial Motor Vehicle (CMV) Percentage: From the drop down list, the approximate truck percentage along a particular roadway needs to be selected. The CMV percentage must be rounded to the nearest integer, as necessary. Choose “2” for truck percentages that are less than 2%; choose “15” for truck percentages that are greater than 15%. It is assumed that there will be no situation where the percent CMV will be less than 2% or greater than 15%.

One- or Two-Directional Volume: This is for one or two directions of traffic entered. It is set to “two-directional volume” by default. One directional volume will typically only be used for one-way streets, major median divided roadways, or instances where the ADT is estimated based on the peak hourly volume for the critical approach or short count at the critical approach.

Number of Traffic Lanes Approaching the Intersection: The number of lanes in the direction that first cross the railroad tracks must be selected, and then when it arrives at the intersection (also referred to as the “critical direction”). DO NOT include turn lanes unless any of the following conditions exist for the critical approach: 1) No through lanes are present (e.g., a T-intersection), 2) Multiple turn lanes exist for a particular turning movement (e.g., dual left-turn lanes, dual right-turn lanes), or 3) Turning volumes are approximately equal to or exceed the through volumes.

Existing Signal Cycle Length: The user should select the total cycle length of the intersection that is being considered – between 60 and 120 seconds. If the cycle length is not available from the drop-down list, round to the nearest value in the list. The user is advised not to use the tool if the signal cycle length greatly exceeds 120 seconds (uncommon in Michigan).

Existing Green Time: The user should enter the actual green time for the critical approach in seconds. This value must range between 5 seconds and the cycle length minus 10 seconds. Values outside of this range will result in an error message.

Distance from the Intersection to 6 feet prior to the Railroad Tracks: The user must enter the distance (estimated) in feet from the intersection stop line to 6 feet prior to the tracks for critical approach. This represents the maximum available queue storage distance for traffic waiting on the critical approach at the signalized intersection.

Viewing Results

When the view button is clicked, if any field is empty or has not been properly filled in, an error message will appear and identify the fields that need to be corrected. Once the inputs are all acceptable, clicking the button will provide the following information:

1. Estimation of the 95th percentile queue length from the intersection to the tracks on the critical approach. It is important to note that queue estimation during oversaturated (entered/estimated traffic volume is greater than capacity) conditions is unreliable. The 95th percentile queue is estimated based on the procedure described in the following subsection.
2. Calculation of the additional distance from the end of the estimated 95th percentile queue to the tracks. If the 95th percentile queue extends past the tracks, the program will state that there is no additional space and will provide the distance beyond the tracks that the queue is predicted to extend.
3. Whether preemption is necessary and why. Preemption is deemed necessary under either of the following: 1) if the distance from the intersection to 6 feet prior to the tracks on the critical approach is less than 200 feet or 2) the estimated 95th percentile queue exceeds the available storage distance, measured from the intersection to 6 feet prior to the tracks.
4. Estimation of the minimum green time required to clear the queue from the tracks to the intersection (for locations where preemption is deemed necessary, up to approximately 80 seconds of track clearance green). This is determined based on the procedures included in the guidelines presented in this report. A separate analysis should be performed for determining track clearance time for cases where greater than 80 seconds of track clearance green is necessary, which occurs for cases where the queue extends to tracks that are at least 800 feet upstream of the intersection.

95th Percentile Queue Calculation

This procedure follows the procedure utilized in Synchro Version 7, as described in the Synchro 7 User Guide (41).

Step 1: Estimate the peak hour lane volume on the critical approach.

$$v_{\text{crit}} = .1 \left(\frac{\text{ADT}}{N_{\text{dir}} N_{\text{lanes}}} \right)$$

Where:

v_{crit} = estimated peak hour lane volume on the critical approach (vehicles per hour per lane)

ADT = Average Daily Traffic [User Input]

N_{dir} = Number of traffic directions (1 or 2) [User Input]

N_{lanes} = Number of traffic lanes approaching the intersection [User Input]

Step 2: Calculate the 95th percentile lane volume on the critical approach.

$$v_{\text{crit95}} = v_{\text{crit}} \left(1 + 1.64 \left(\frac{\sqrt{v_{\text{crit}} * C / 3600}}{v_{\text{crit}} * C / 3600} \right) \right)$$

Where:

v_{crit95} = estimated 95th percentile peak hour lane volume on the critical approach (vehicles per hour per lane)

C = cycle length (seconds) [User Input]

Step 3: Determine if the 95th percentile approach volume represents oversaturated traffic conditions.

Assume oversaturated traffic conditions if

$$v_{\text{crit95}} \geq \left(\frac{g}{C} \right) 1800, \text{ where } g = \text{green time on the critical approach (sec)}$$

Assume undersaturated traffic conditions if

$$v_{\text{crit95}} < \left(\frac{g}{C} \right) 1800, \text{ where } g = \text{green time on the critical approach (sec)}$$

Step 4: Calculate the length of the 95th percentile queue on the critical approach.

For undersaturated traffic conditions:

$$Q_{95} = \frac{v_{\text{crit95}}}{3600} (C - g - 3) \left(1 + \frac{1}{\frac{1800}{v_{\text{crit95}}} - 1} \right) * 25 * \text{Length Adj.}$$

Where:

Q_{95} = estimated 95th percentile peak hour queue length on the critical approach (ft)

C = cycle length (seconds) [User Input]

25 = assumed vehicle storage length in queue (ft)

Length Adj. = Vehicle length adjustment factor to account for trucks (see Table 4)

For oversaturated traffic conditions:

$$Q_{95} = 2 \left(\frac{v_{crit95} * C}{3600} - \frac{1800 * g^2}{C * 3600} \right) * 25 * \text{Length Adj.}$$

Table 4. Vehicle Length Adjustment Factors Based on Truck Percentages

% TRUCKS	AVERAGE VEHICLE LENGTH	LENGTH ADJUSTMENT FACTOR
2	25.65	1.026
3	25.975	1.039
4	26.3	1.052
5	26.625	1.065
6	26.95	1.078
7	27.275	1.091
8	27.6	1.104
9	27.925	1.117
10	28.25	1.13
11	28.575	1.143
12	28.9	1.156
13	29.225	1.169
14	29.55	1.182
15	29.875	1.195

Assumptions: Standard veh. space = 25 ft
 Single unit truck space = 40 ft
 Semi trailer truck space = 75 ft
 50/50 split between single units and semis
 Avg. length is weighted average considering all units

On-line version of the preemption assessment tool is available at

<https://docs.wayne.edu/5012e76769d85/>

VIII. CONCLUSION AND RECOMMENDATIONS

The study of “Timing Issues for Traffic Signal Interconnected with Highway-Railroad Grade Crossings” revealed that there are several phasing and timing related issues that are critical to safety and operations at interconnected traffic signals located in close proximity to railroad crossings. These issues need to be resolved in order to minimize the risk of future crashes and address operational inefficiencies. Crashes involving automobiles and trains are rare events. However, such crashes are generally severe and often have far reaching impact in the community at large. This research study included:

- A review of the state-of-the-art and state-of-the-practice related to timing issues for traffic signals interconnected with highway-railroad grade crossings.
- Development of a series of templates for interconnected signal timing and phasing design as appropriate for specific site characteristics.
- Development of “The Railroad Preemption Assessment Tool”, which can be used by practitioners to help evaluate the need for preemption at a signalized intersection that is near railroad tracks.

The outcome of this research satisfied the study objectives included in the proposal. A brief summary of the conclusions are as follows:

1. The traffic signal timing and phasing design of signalized intersections located near a railroad crossing is critical to minimizing potential train-motor vehicle crashes.
2. Most states follow the 200 feet rule for available clear storage distance as provided in the MUTCD for identifying candidate intersections for preemption.
3. There are a few states, as identified earlier in the report, that consider queue build-up characteristics at signalized intersections that encroach onto the railroad track in spite of being located beyond the 200 feet envelope.
4. There are some templates available that provide guidance as to the design of traffic signal timing and phasing of interconnected intersections located in close proximity to railroad crossings.
5. Several templates for design consideration of interconnected traffic signal timing and phasing have been developed as a part of this project. These templates will provide

guidance for the design and evaluation of interconnected traffic signals located near railroad crossings.

6. Queue formation and dissipation characteristics have been investigated as to how they influence signal timing design, as well as in assessing the need for interconnection and preemption. A software tool has been developed to facilitate future design and decision of determining preemption needs.
7. The templates have been prepared for the most conservative scenarios to minimize the chances of queue encroachment onto the railroad tracks.

This report and the accompanying templates and software tool should facilitate future decision-making involving the selection of candidates for signal preemption, the design of traffic signal phasing and timing, and the selection of other traffic control sign and signal infrastructure based on the roadway geometry and existing traffic control characteristics.

IX. IMPLEMENTATION STRATEGY

The study findings, software tool and templates developed as a part of the project titled, “Timing Issues for Traffic Signal Interconnected with Highway-Railroad Grade Crossings” are available for use and implementation immediately. Safety and operational improvements may be realized as consideration for design modifications are evaluated and implemented in the field.

Implementation initiatives should be consistent with available resources, as noted above, and phased in over time. Utilization of the study recommendations can be done gradually and these recommendations have been designed to:

- Minimize safety risk
- Improve operational efficiency
- Simplify the design and decision-making processes for users.
- Improve motorists’ compliance which traffic control at and near railroad crossing locations

The following provides a summary of implementation strategies for the results of this project:

1. Conduct short workshops/presentations with various groups within MDOT. This will assist in facilitating internal buy-in by the MDOT constituent personnel.
2. Provide such training to county personnel, city/township officials and other professionals regarding the availability of the software tool and templates. The number of intersections in close proximity to railroad crossings that are owned by other agencies is probably three to four times the number owned by MDOT. While enforcement authority for all such locations lies with the state, changes in traffic signals in close proximity to railroad crossings may require the local road agency administration’s and technical personnel’s approval.
3. Prepare targeted awareness campaign materials and a short training program for local agencies in Michigan.
4. The optional proposed timing and phasing recommendations, as well as sign and signal infrastructure modification should be considered for implementation to enhance future safety and efficiency.

X. REFERENCES

1. U.S. Department of Transportation. *Implementation Report of the USDOT Grade Crossing Safety Task Force*, Report to Secretary Rodney E. Slater, June 1, 1997.
2. USDOT Technical Working Group. *Implementation Report of the USDOT Grade Crossing Safety Task Force*, U.S. Department of Transportation, Washington D.C., June 1997.
3. Marshall, P. S. (1997). "An Investigation of Railroad Pre-emption at Signalized Intersections." *Department of Civil Engineering, University of Wisconsin, Madison, May, 1989*.
4. Korve, H. W. (1999). "NCHRP Synthesis of Highway Practice 271: Traffic Signal Operations Near Highway-Rail Grade Crossings." *TRB, National Research Council, Washington, D.C.*
5. FHWA,. (2009). *Manual on Uniform Traffic Control Devices for Streets and Highways, Part 8, Traffic Control for Railroad and Light Rail Transit Grade Crossings*.
6. Oppenlander, J. C., and Oppenlander, J. E. (1996). "Storage Requirements for Signalized Intersection Approaches." *Institute of Transportation Engineers Journal*, P. 27-30.
7. FHWA,. (2009). *Manual on Uniform Traffic Control Devices for Streets and Highways, Part 4, Highway Traffic Signals*.
8. Code of Federal Regulations. Title 49, Part 234.225. *Activation of Warning Systems*.
9. Cho, H., and Rilett, L. R. (2007). "Improved Transition Preemption Strategy for Signalized Intersections near At-Grade Railway Grade Crossing." *Journal of Transportation Engineering-ASCE*, 133(8), P. 443-454.
10. Ruback, L. G., Balke, K., and Engelbrecht, R. (2007). "Non-Vital Advance Rail Preemption of Signalized Intersections near Highway-Rail Grade Crossings." *Texas Transportation Institute. The Texas A&M University System*.
11. Sun, X., Urbanik, T., Skehan, S., and Ablett, M. (2008). "Improved Highway-Railway Interface for the Preempt Trap." *Transportation Research Record: Journal of the Transportation Research Board*(2080), P. 1-7.
12. Brennan Jr, T., Day, C., Sturdevant, J., and Bullock, D. (2010). "Railroad Preempted Intersection Track Clearance Performance Measures." *Transportation Research Board 89th Annual Meeting*.
13. Long, G. (2003). "Easy-to-Apply Solution to a Persistent Safety Problem: Clearance Time for Railroad-Preempted Traffic Signals." *Transportation Research Record: Journal of the Transportation Research Board*(1856), P. 239-247.
14. Zhang, L., Hobeika, A., and Ghaman, R. (2002). "Optimizing Traffic Network Signals Around Railroad Crossings: Model Validations." *Transportation Research Record: Journal of the Transportation Research Board*(1811), P. 139-147.

15. Marshall, P. S., and Berg, W. D. (1997). "Design Guidelines for Railroad Preemption at Signalized Intersections." *Institute of Transportation Engineers*, 67(2), P. 20-25.
16. Wooldridge, M. D., Fambro, D. B., Brewer, M. A., Engelbrecht, R. J., Harry, S. R., and Cho, H. (2000). "Design Guidelines For At-Grade Intersections Near Highway-Railroad Grade Crossings." Texas Transportation Institute, The Texas A&M University System.
17. Oppenlander, J. C., and Oppenlander, J. E. (1994). "Storage Lengths for Left-Turn Lanes with Separate Phase Control." *Institute of Transportation Engineers Journal*, P. 22-26.
18. Oppenlander, J. C., and Oppenlander, J. E. (1999). "Storage Requirements for Signalized Intersection Approaches-Uniform Arrivals." *Institute of Transportation Engineers Journal*, P. 84-88.
19. Oppenlander, J. C., and Oppenlander, J. E. (2002). "Simulation of Left Turn Storage Lengths without Separate Signal Phase." *Institute of Transportation Engineers Journal*, P. 34-38.
20. ITE Traffic Engineering Council Committee, Recommended Practice. *Pre-emption of Traffic Signals At or Near Railroad Grade Crossings with Active Warning Devices*, Institute of Transportation Engineers, Washington D.C., 1997.
21. Cho, H., and Rilett, L. (2009). "Analysis of Performance of Transitional Preemption Strategy for Traffic Signal near At-Grade Railway Grade Crossing." *Transportation Research Board 88th Annual Meeting*.
22. Engelbrecht, R., Sunkari, S., Urbanik, T., Venglar, S., and Balke, K. "The Preempt Trap: How to Make Sure You Do Not Have One." Texas Transportation Institute, Texas A&M University, 2002.
23. Long, G. (2002). "Clearance Time Requirements at Railroad-Preempted Traffic Signals." *Final Report, Department of Civil and Coastal Engineering, University of Florida, Gainesville, FL*.
24. SCDOT. *Traffic Signal Design Guidelines 2009 Edition*, South Carolina Department of Transportation.
25. TDOT. (March 2011). *Traffic Design Manual*, Design Division, Tennessee Department of Transportation.
26. GDOT. (February 2011). *Signal Design Guidelines*, Georgia Department of Transportation.
27. NYDOT. (Effective March 16, 2011). *New York State Supplement to the Manual on Uniform Traffic Control Devices for Streets and Highways (2009 Edition)*, New York State Department of Transportation.
28. Venglar, S. P., Jacobson, M. S., Sunkari, S. R., Engelbrecht, R. J., and Urbanik II, T. (September 2000). "Guide for Traffic Signal Preemption Near Railroad Grade Crossing, FHWA/TX-01/1439-9."

29. WSDOT. (July 2010). *Design Manual, Division 13 Intersections and Interchanges*, Washington State Department of Transportation.
30. MDOT. (2011). *Michigan Manual of Uniform Traffic Control Devices*, Michigan Department of Transportation.
31. ODOT. (October 19, 2005). *Traffic Signal Guidelines, Traffic Management Section*, Oregon Department of Transportation.
32. Ogden, B. D. (2007). "Railroad-Highway Grade Crossing handbook-Revised Second Edition 2007." Technical Report FHWA-SA-07-010, Office of Safety Design Federal Highway Administration.
33. Long, G. (2000). "Acceleration characteristics of starting vehicles." *Transportation Research Record: Journal of the Transportation Research Board*, 1737, P. 58-70.
34. MnDOT. (2006). *Guide for Determining Time Requirements for Traffic Signal Preemption at Highway-Rail Grade Crossings*, Minnesota Department of Transportation.
35. MDOT. (2010). *Michigan Signal Optimization Guidelines (6th Edition)*, Michigan Department of Transportation, Department of Traffic and Safety.
36. Institute of Transportation Engineers, 2006. *Preemption of Traffic Signals Near Railroad Crossings: An ITE Recommended Practice.*, Prepared by Traffic Engineering Council Committee TENC-99-06. Washington, DC.
37. Michigan Legislature. Railroad Code of 1993 (Excerpt), Act 354 of 1993. Section 462.391. *Obstruction of vehicular traffic; offenses as separate violations; penalty; allocation of fines.*
38. Long, G. (2005). "Start-up delays of queued vehicles." *Transportation Research Record: Journal of the Transportation Research Board*, 1934, P.125-131.
39. HCM. (2000). *Highway Capacity Manual*, Transportation Research Board, Washington, DC.
40. Davidson, B. M. "Traffic Signal Timing Utilizing Probability Curves." *Traffic Engineering, Institute of Traffic Engineers*, Vol. 32, No. 2, November, 1961.
41. Husch, D., and Albeck, J. (2006). "Synchro Studio 7 user guide." *Trafficware, Sugar Land, TX.*

**APPENDIX A. EXISTING STATE DOT PREEMPTION SIGNAL TIMING
TEMPLATES**

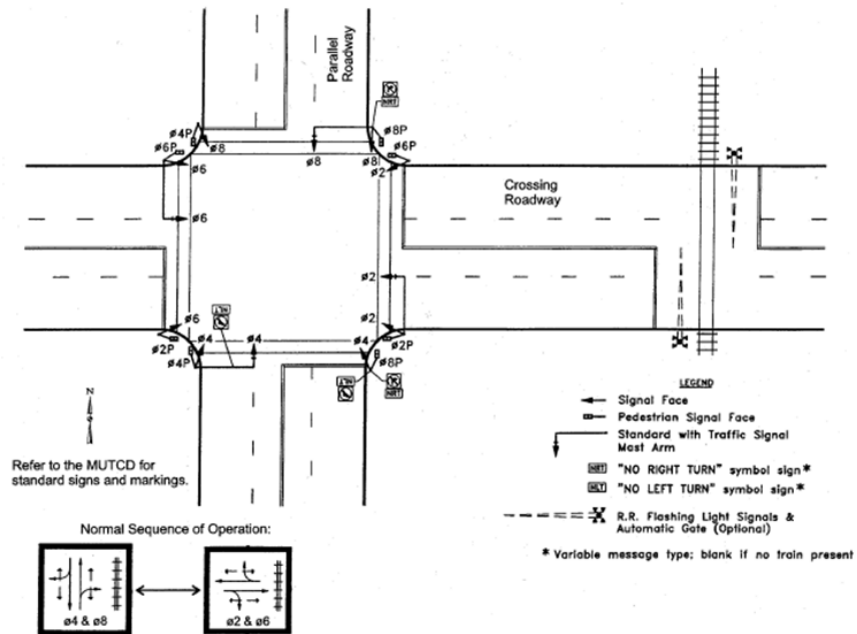

FIGURE 11 Two-phase traffic signal near a highway-rail grade crossing (from (5)).

Figure A-1. ITE Recommended Practice, Preemption of Traffic Signal near or at Highway Railroad Grade Crossing with Active Warning Devices

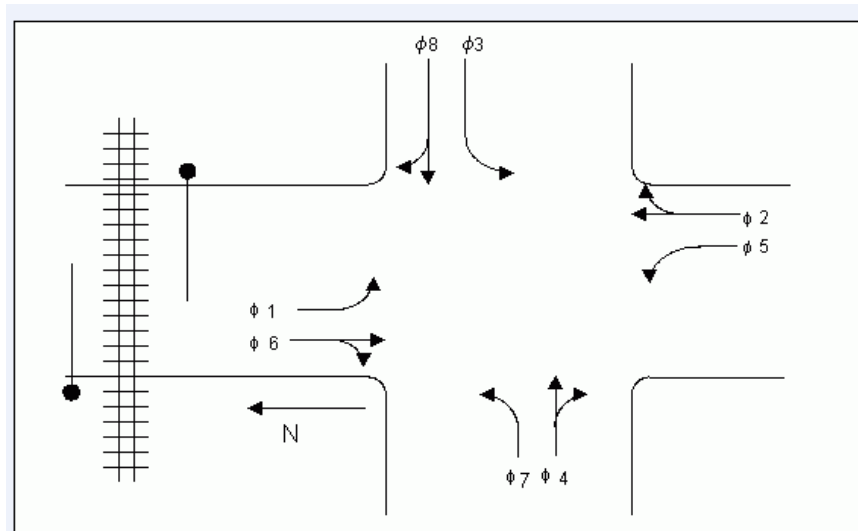

Figure A-2. Missouri (Phasing and Timing the Signal- Engineering Policy Guide)

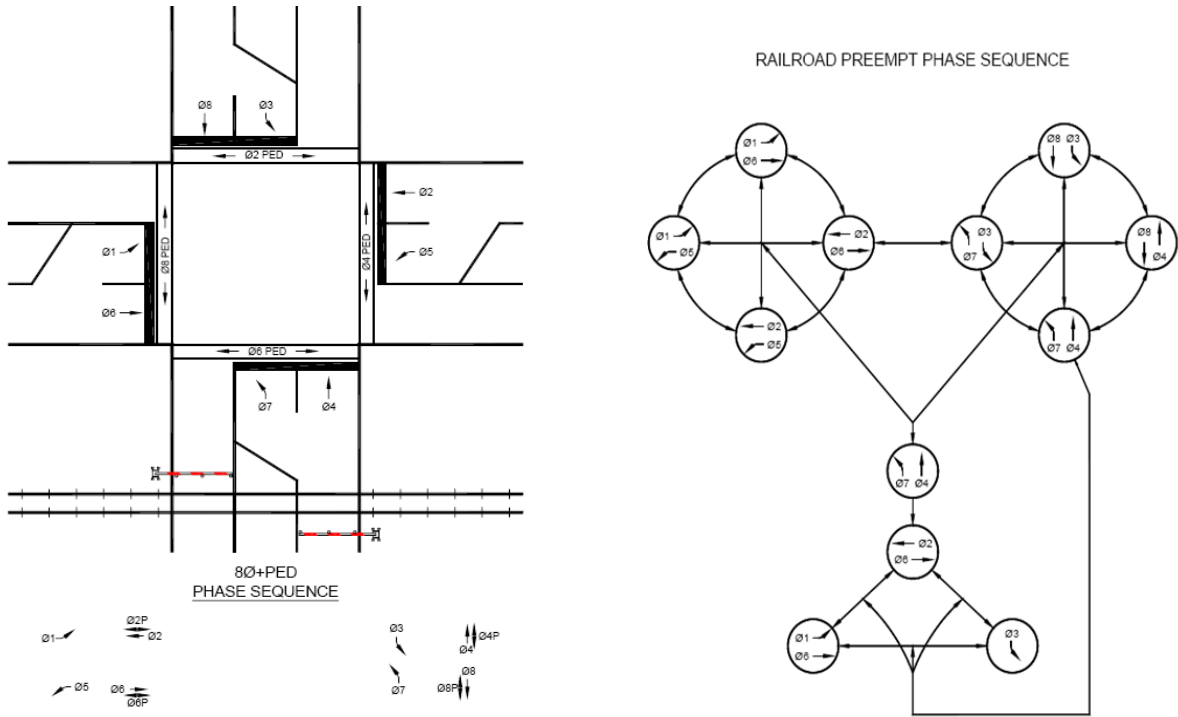

Figure A-3. Minnesota DOT (Guide for Determining the Time Requirements for Traffic Signal Preemption at Highway-Rail Grade Crossings)

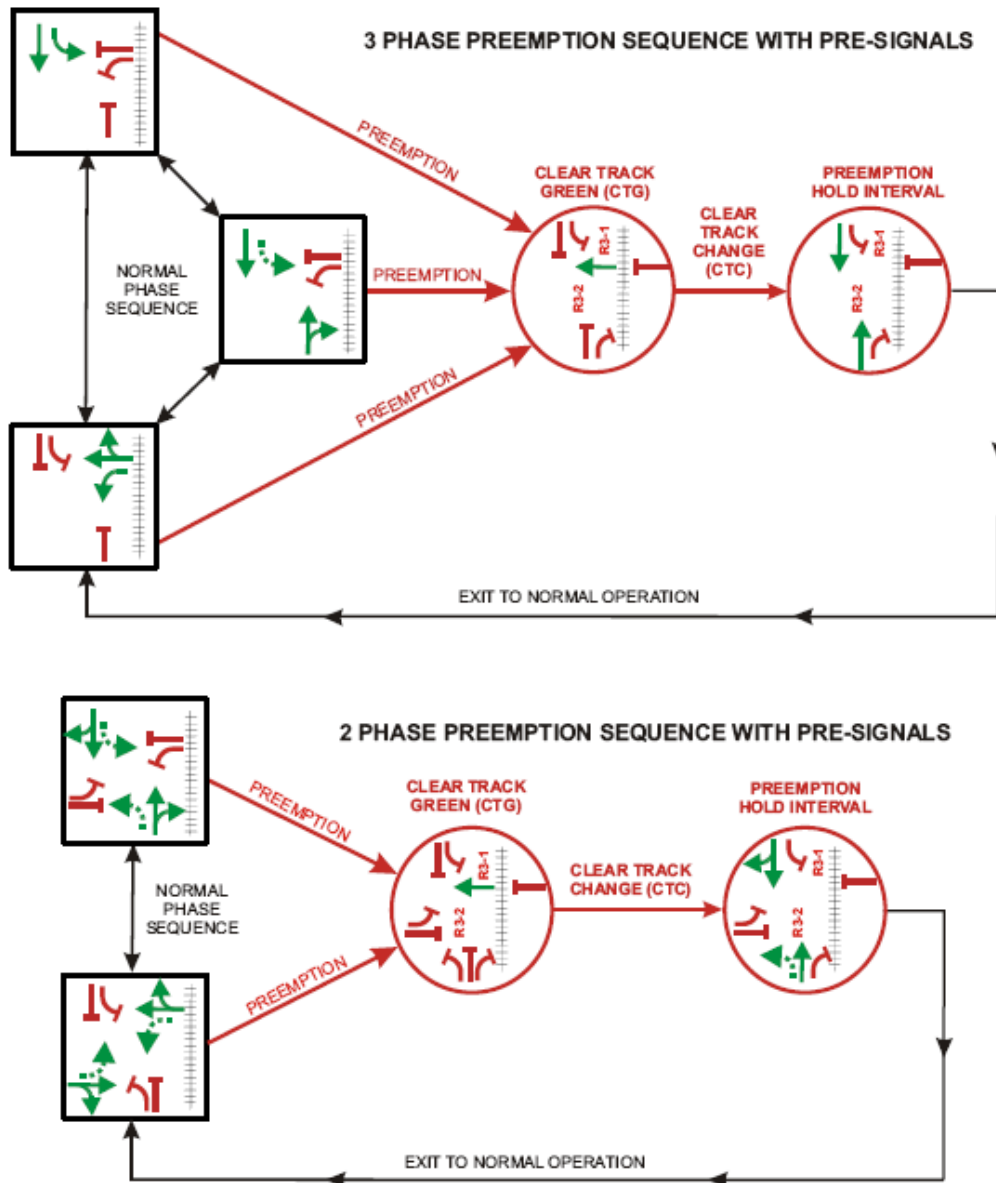

Figure A-4. Tennessee DOT Traffic Design Manual

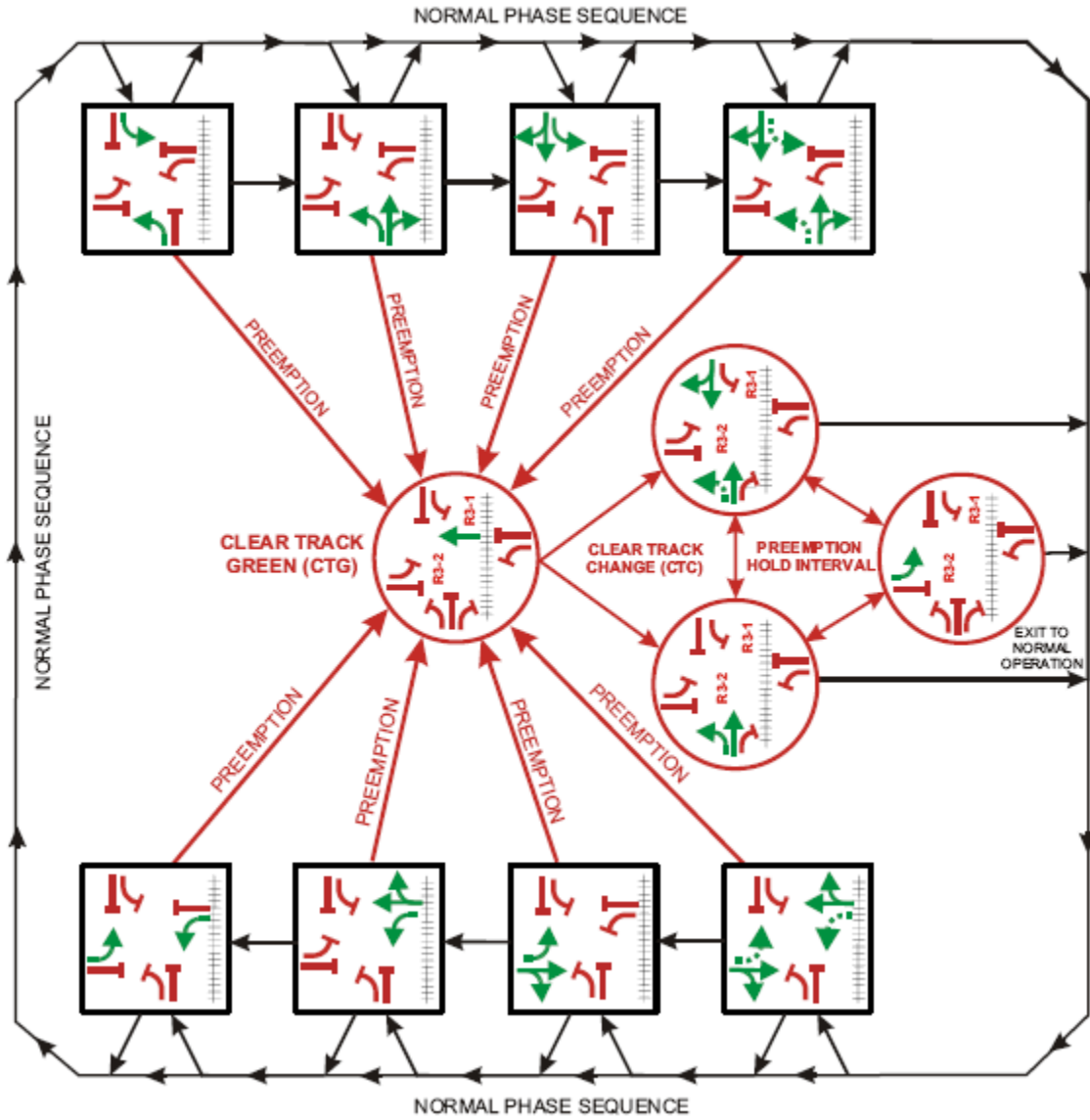
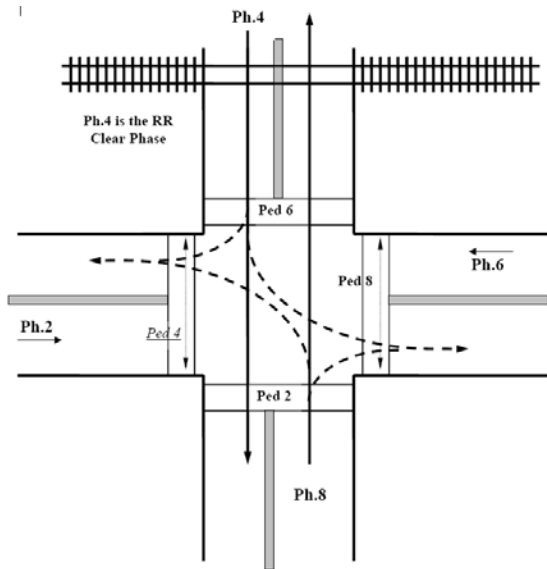
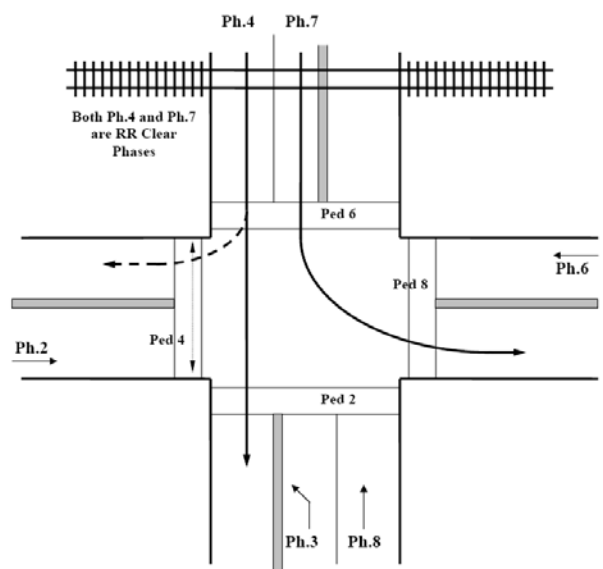

Figure A-5. Eight Phase Operation with Pre-Signal (Tennessee)



Concurrent Phasing without Left Turn



Concurrent Phasing with Left Turn Protection

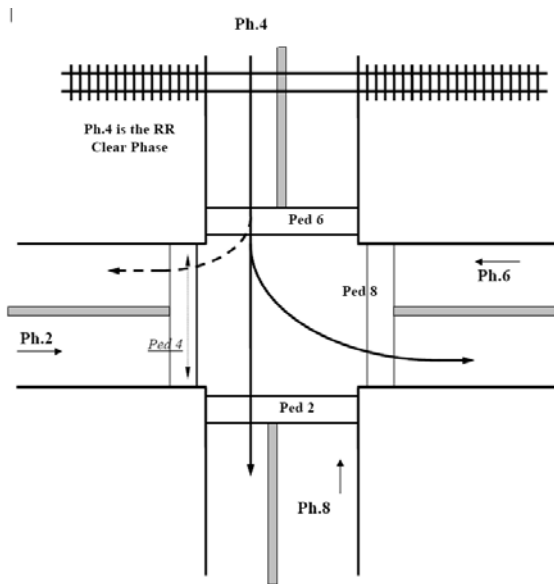

Split (Non-Concurrent) Phasing

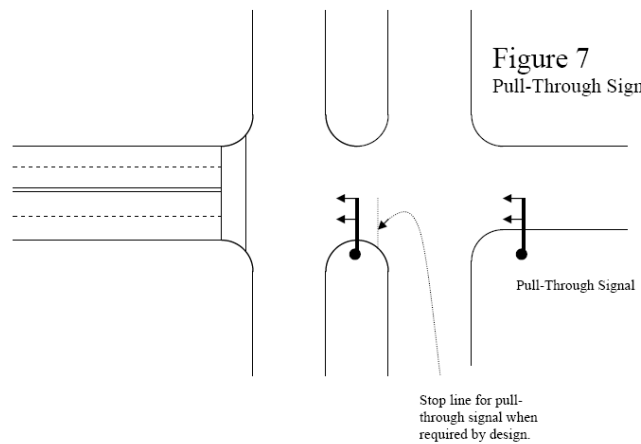

Pull-through Signal

Figure 7
Pull-Through Signal

Figure A-6. Oregon DOT Railroad Preemption Design and Operation

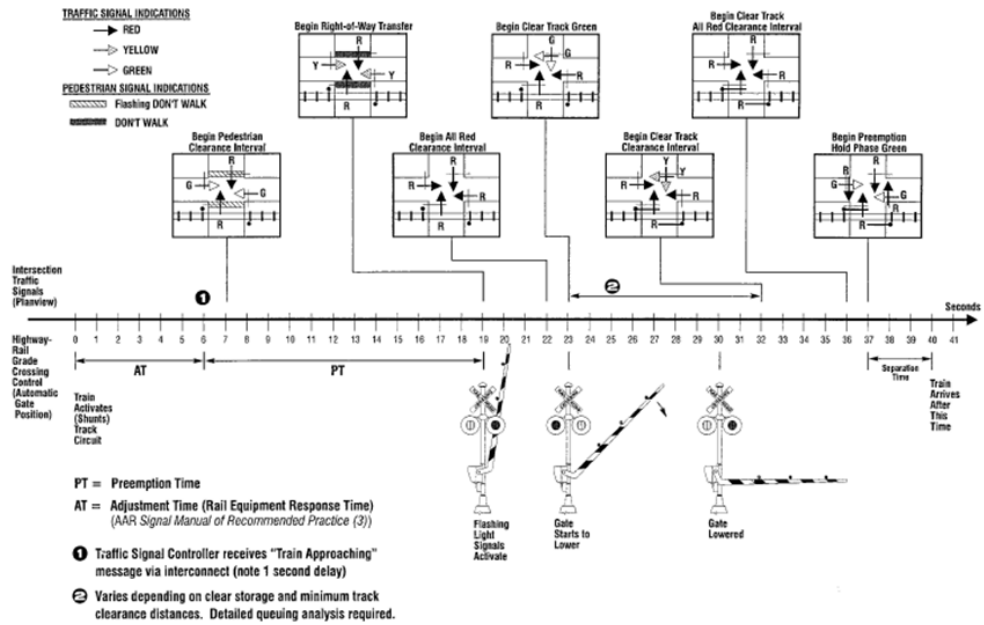

FIGURE 15 Sample advance preemption time line.

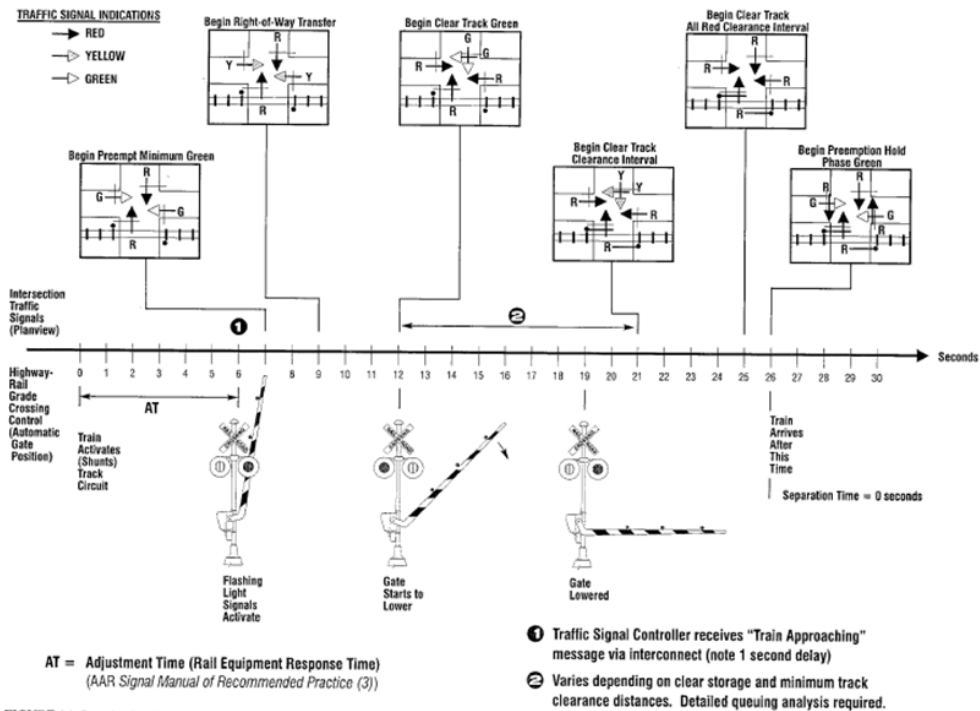

FIGURE 14 Sample simultaneous preemption time line (from (2)).

Figure A-7. Texas Guide for Signal Preemption at Highway Railroad Grade Crossing

**APPENDIX B. LOCATION SUMMARY DATA FOR INTERCONNECTED RAILROAD
CROSSINGS/SIGNALIZED ROADWAY INTERSECTIONS IN MICHIGAN**

MDOT RR#	Intersecting Road Name	ADT	% Truck	RR Owner	MDOT Signal?	City/Township	County	RR Speed	Pedestrian Facilities?	Gates?	Long.	Lat.
03025	Beecher/M-34	9,400	5	ADBF	Yes	Adrian	Lenaawce	10	No	No	-84.058	41.889
02154	Superior Street/M-99	6,300	2	NS	Yes	Albion	Calhoun	40	Yes	Yes	-84.753	42.246
04221	West Superior Street	8,382	7	MDOT	Yes	Alma	Gratiot	20	No	No	-84.667	43.379
03901	Kendall Street	3,300	6	GTW	Yes	Battle Creek	Calhoun	30	Yes	Yes	-85.200	42.320
04661	CR 633/Silver Lake Road	8,156	6	MDOT	Yes	Blair	Grand Traverse	10	No	No	-85.690	44.665
04006	M-52/Main Street	17,900	4	NS	Yes	Chelsea	Washtenaw	79	No	Yes	-84.021	42.319
00691	Mount Hope Road	7,287	6	GTW	Yes	Delta	Eaton	65	No	Yes	-84.610	42.712
03113	M-102 (Eight Mile)	64,000	3	GTW	Yes	Detroit	Wayne	45	Yes	Yes	-83.036	42.426
03286	Newman Street	11,000	5	LSRC	Yes	East Tawas	Iosco	10	No	Yes	-83.490	44.280
05292	Elkhart Street	3,349	7	GTW	Yes	Edwardsburg	Cass	60	Yes	Yes	-86.082	41.795
07128	Luna Pier Road/US-24	2,400	8	CSX	Yes	Eric	Monroe	45	No	Yes	-83.499	41.809
07151	35th Street	4,500	6	NS	Yes	Galesburg	Kalamazoo	79	No	Yes	-85.429	42.289
05079	Cottonwood Drive	18,208	6	CSX	Yes	Georgetown	Ottawa	30	No	Yes	-85.792	42.904
03331	12th Avenue	9,019	7	CSX	Yes	Georgetown	Ottawa	30	No	Yes	-85.812	42.896
01809	Port Sheldon Street	17,504	7	CSX	Yes	Georgetown	Ottawa	65	No	Yes	-85.834	42.886
08917	South Hill Road	3,000	5	WC	Yes	Gladstone	Delta	20	No	No	-87.040	45.836
04430	Lake Michigan Drive	1,695	n/a	CSX	Yes	Grand Haven	Ottawa	40	No	No	-86.183	42.972
10295	Ferris Street	3,852	5	CSX	Yes	Grand Haven	Ottawa	40	No	No	-86.206	43.008
03214	Fulton Street/M-45	11,500	2	CSX	Yes	Grand Rapids	Kent	10	Yes	No	-85.682	42.963
02770	Main Street	1,800	6	LSRC	Yes	Harrisville	Alcona	10	No	No	-83.295	44.657
03388	32nd Avenue	12,495	7	CSX	Yes	Hudsonville	Ottawa	40	No	Yes	-85.861	42.871
03724	36th Street	5,251	5	CSX	Yes	Hudsonville	Ottawa	35	No	Yes	-85.871	42.865
01467	Henry Ruff Road	3,800	6	NS	Yes	Inkster	Wayne	70	No	Yes	-83.339	42.286
02335	West Michigan Avenue	6,319	7	ATK	Yes	Kalamazoo	Kalamazoo	45	No	Yes	-85.601	42.288
02186	Oliver Street	10,200	5	ATK	Yes	Kalamazoo	Kalamazoo	60	No	Yes	-85.606	42.284
02809	Howard Street	27,392	9	ATK	Yes	Kalamazoo	Kalamazoo	79	No	Yes	-85.615	42.276
02810	Kalamazoo Street/I-94BL	10,500	6	GDLC	Yes	Kalamazoo	Kalamazoo	15	No	Yes	-85.579	42.295
03740	Waverly Road	19,900	40	GTW	Yes	Lansing	Ingham	40	No	Yes	-84.603	42.717
13380	Grand River Ave @ MLK Dr	15,200	2	NS	Yes	Lansing	Ingham	15	No	No	-84.567	42.760
05040	South Hudson Street	17,203	11	MMRR	Yes	Lowell	Kent	10	Yes	Yes	-85.342	42.933
07912	State Street	3,150	20	MDOT	Yes	Mancelona	Antrim	25	Yes	No	-85.060	44.902
01762	I94BL(Gratiot)	9,800	4	CSX	Yes	Marysville	St. Clair	10	Yes	No	-82.799	42.732
08818	Albain Road	4,240	5	CSX	Yes	Monroe	Monroe	45	No	Yes	-83.436	41.886
07617	18th Avenue	9,884	5	CSX	Yes	N/A	Ottawa	60	No	No	-83.112	42.446
07558	Getty Street	4,608	7	CSX	Yes	Norton Shores	Muskegon	25	No	No	-86.225	43.186

MDOT RR#	Intersecting Road Name	ADT	%Truck	RR Owner	MDOT Signal?	City/Township	County	RR Speed	Pedestrian Facilities?	Gates?	Long-	Lat.
10556	Port Sheldon Street	4,896	7	CSX	Yes	Olive	Ottawa	40	No	No	-86.124	42.885
01885	Woodward/M-1	29,700	2	GTW	Yes	Pontiac	Oakland	45	No	Yes	-83.282	42.623
04394	M-18/Lake Street	5,000	2	MDOT	Yes	Roscommon	Roscommon	10	No	Yes	-84.592	44.499
07344	South Washington Ave/M-13	11,500	5	HESR	Yes	Saginaw	Saginaw	10	No	No	-83.942	43.426
10294	Hayes Street	2,579	5	CSX	Yes	Spring Lake	Ottawa	40	No	No	-86.219	43.030
10283	M-55/Hemlock Street	4,800	4	LSRC	Yes	Tawas City	Iosco	10	No	No	-83.510	44.274
04698	Broadway Street	4,430	6	GDLK	Yes	Three Rivers	St. Joseph	25	Yes	Yes	-85.627	41.933
04258	Michigan Avenue (M-60)	6,200	8	GDLK	Yes	Three Rivers	St. Joseph	30	Yes	Yes	-85.627	41.931
02028	Watkins Lake Road	4,068	6	GTW	Yes	Waterford	Oakland	60	No	Yes	-83.357	42.676
05096	South State Street	20,000	9	AA	No	Ann Arbor	Washtenaw	10	No	No	-83.740	42.260
02971	West Liberty Street	8,000	7	AA	No	Ann Arbor	Washtenaw	10	Yes	No	-83.751	42.279
04045	Barton Street	7,500	5	AA	No	Ann Arbor	Washtenaw	10	Yes	No	-83.731	42.296
10827	22nd Street	12,831	6	SBS	No	Bangor	Bay	10	No	Yes	-83.867	43.580
05992	Elm Street	4,500	6	GTW	No	Battle Creek	Calhoun	30	Yes	Yes	-85.172	42.312
04380	Sterns Road	3,090	7	CSX	No	Bedford	Monroe	45	No	Yes	-83.532	41.750
02388	Robinson Road	10,667	15	NS	No	Blackman	Jackson	79	No	Yes	-84.462	42.254
07937	North Lane Street	1,800	6	ADBF	No	Blissfield	Lenawee	10	No	No	-83.862	41.833
07936	North Monroe Street	1,800	7	ADBF	No	Blissfield	Lenawee	10	No	No	-83.869	41.835
00441	Opydke Road	16,486	7	GTW	No	Bloomfield	Oakland	60	No	Yes	-83.248	42.598
03316	King Road	2,526	11	SBS	No	Bridgeport	Saginaw	50	No	No	-83.891	43.379
04052	Center Road	18,225	9	GTW	No	Burton	Genesee	10	No	No	-83.635	43.026
04191	10 Mile Road	22,204	6	CRSH	No	Center Line	Macomb	15	No	Yes	-83.038	42.477
02658	11 Mile Road	16,803	6	CRSH	No	Center Line	Macomb	30	No	Yes	-83.038	42.491
03016	23 Mile Road	27,601	8	GTW	No	Chesterfield	Macomb	49	No	Yes	-82.839	42.675
07727	Chesterfield Road	3,790	16	GTW	No	Chesterfield	Macomb	49	No	Yes	-82.838	42.676
03718	Metropolitan Parkway	38,637	10	GTW	No	Clinton	Macomb	49	No	Yes	-82.915	42.569
04143	26th Street	4,930	6	NS	No	Comstock	Kalamazoo	79	No	Yes	-85.511	42.289
02358	Schaefer Road	11,200	14	CRSH	No	Dearborn	Wayne	15	No	No	-83.175	42.303
13419	Miller Road	7,381	30	FMCZ	No	Dearborn	Wayne	5	No	Yes	-83.149	42.299
05980	Mason Street	5,610	5	NS	No	Dearborn	Wayne	70	No	Yes	-83.245	42.304
08665	Central Avenue	11,884	10	CRSH	No	Detroit	Wayne	60	No	Yes	N/A	N/A
02135	Central Ave	11,884	10	CRSH	No	Detroit	Wayne	10	No	Yes	-83.131	42.322
02644	Oakwood	11,735	4	CRSH	No	Detroit	Wayne	15	No	Yes	-83.160	42.286
02136	Lonyo Road	8,898	7	CRSH	No	Detroit	Wayne	60	No	Yes	-83.138	42.321
05037	Menichols	6,708	2	CRSH	No	Detroit	Wayne	10	No	No	-83.038	42.419
04950	St Jean Street	4,946	3	CRSH	No	Detroit	Wayne	10	No	No	-82.986	42.391
08637	Shoemaker Street	7,946	4	CRSH	No	Detroit	Wayne	10	No	Yes	-82.985	42.391

MDOT RR#	Intersecting Road Name	ADT	%Truck	RR Owner	MDOT Signal?	City/Township	County	RR Speed	Pedestrian Facilities?	Gates?	Long.	Lat.
02037	Mound & Davison	18,799	4	CRSH	No	Detroit	Wayne	10	No	No	-83.043	42.422
00372	West Chicago Boulevard	9,783	3	CSX	No	Detroit	Wayne	45	No	Yes	-83.217	42.365
04850	Plymouth Road/M-14	4,578	7	CSX	No	Detroit	Wayne	10	No	No	-83.158	42.374
04851	Wyoming Avenue	10,521	7	CSX	No	Detroit	Wayne	10	No	No	-83.159	42.374
02361	Schaefer Road	16,464	5	CSX	No	Detroit	Wayne	10	No	Yes	-83.178	42.380
04771	Hubbell Avenue	6,386	5	CSX	No	Detroit	Wayne	10	No	Yes	-83.188	42.380
03268	Oakland Avenue	2,117	3	GTW	No	Detroit	Wayne	45	Yes	Yes	-83.095	42.424
03268	Nevada Avenue	1,547	5	GTW	No	Detroit	Wayne	45	Yes	Yes	-83.095	42.425
09612	Three Mile Road	20,735	7	MDOT	No	East Bay	Grand Traverse	20	No	No	-85.561	44.746
02390	Harrison Road	14,274	7	CSX	No	East Lansing	Ingham	40	Yes	Yes	-84.494	42.718
02391	Harrison Road	17,851	7	GTW	No	East Lansing	Ingham	65	No	Yes	-84.494	42.719
13465	Tawas Beach Road	4,209	10	LSRC	No	East Tawas	Iosco	10	No	No	N/A	N/A
01480	Main Street/US-12	5,600	21	GTW	No	Edwardsburg	Cass	60	No	Yes	-86.078	41.800
03271	Leroy Street	6,327	9	GTW	No	Fenton	Genesee	60	No	Yes	-83.705	42.798
03080	Atherton Road	14,137	5	CSX	No	Flint	Genesee	35	No	Yes	-83.649	42.989
02400	Western Road	7,941	6	CSX	No	Flint	Genesee	35	No	Yes	-83.656	43.043
02400	Leith Street	3,104	6	CSX	No	Flint	Genesee	35	No	Yes	-83.656	43.043
01683	Averill Avenue	4,822	6	GTW	No	Flint	Genesee	10	No	No	-83.645	43.026
04964	Van Slyke Road	17,526	7	GTW	No	Flint	Genesee	65	No	Yes	-83.713	42.990
10117	Brimley Road	7,562	10	MDOT	No	Garfield	Grand Traverse	10	No	No	-85.616	44.708
06615	Genesee Road	12,430	5	HRR	No	Genesee	Genesee	15	No	Yes	-83.617	43.110
07840	Fort Road	5,618	7	CRSH	No	Gibraltar	Wayne	50	No	Yes	-83.225	42.096
07587	Gibraltar Road	14,443	7	CRSH	No	Gibraltar	Wayne	50	No	Yes	-83.226	42.095
08155	7th Street	4,166	1	CSX	No	Grand Haven	Ottawa	10	No	No	-86.223	43.061
08155	Washington Road	5,205	n/a	CSX	No	Grand Haven	Ottawa	10	No	No	N/A	N/A
01419	Hall Street	11,869	7	CSX	No	Grand Rapids	Kent	25	No	Yes	-85.672	42.942
04873	Market Street	7,142	7	CSX	No	Grand Rapids	Kent	10	Yes	Yes	-85.679	42.957
03050	Lake Michigan Drive	15,472	7	CSX	No	Grand Rapids	Kent	10	Yes	Yes	-85.681	42.966
06493	Bridge Street	12,276	7	CSX	No	Grand Rapids	Kent	10	No	No	-85.682	42.971
02592	Plainfield Avenue	11,842	9	GR	No	Grand Rapids	Kent	25	Yes	No	-85.667	42.985
02592	Leonard Street	27,635	9	GR	No	Grand Rapids	Kent	25	Yes	No	-85.667	42.985
04820	Ivanrest Avenue	3,742	5	CSX	No	Grandville	Kent	30	No	Yes	-85.744	42.919
04826	Wilson Avenue	23,094	7	CSX	No	Grandville	Kent	30	Yes	Yes	-85.763	42.910
01298	120th Avenue	15,689	5	CSX	No	Holland	Ottawa	35	No	Yes	-86.078	42.804
11532	Lincoln Avenue	2,928	7	CSX	No	Holland	Ottawa	35	No	No	-86.097	42.790
12376	9th Street	10,000	5	CSX	No	Holland	Ottawa	35	No	No	-86.098	42.789
06994	Roost Avenue	2,200	5	CSX	No	Holland	Ottawa	10	No	Yes	-86.098	42.805

MDOT RR#	Intersecting Road Name	ADT	% Truck	RR Owner	MDOT Signal?	City/Township	County	RR Speed	Pedestrian Facilities?	Gates?	Long.	Lat.
12399	North Mechanic Street	3,037	6	NS	No	Jackson	Jackson	30	Yes	No	-84.406	42.249
09062	Laurence Avenue	9,990	7	NS	No	Jackson	Jackson	79	No	Yes	-84.448	42.252
03458	Cooper Street/M-106	27,000	12	NS	No	Jackson	Jackson	45	No	Yes	-84.401	42.248
02141	East Michigan Avenue/1-94bl	20,000	10	NS	No	Jackson	Jackson	79	Yes	Yes	-84.401	42.248
02513	North Frances Street	4,693	10	NS	No	Jackson	Jackson	45	No	Yes	-84.403	42.249
02068	Main Street	20,252	7	CSX	No	Jenison	Ottawa	60	No	Yes	-85.786	42.905
02203	Westmege Street/US-131	8,091	11	ATK	No	Kalamazoo	Kalamazoo	45	No	Yes	-85.590	42.295
05978	Drake Road	28,346	11	ATK	No	Kalamazoo	Kalamazoo	79	No	Yes	-85.648	42.277
10587	Vine Street	4,914	7	GDLC	No	Kalamazoo	Kalamazoo	25	No	No	-85.574	42.284
12171	Portage Street	14,909	9	GDLC	No	Kalamazoo	Kalamazoo	25	No	Yes	-85.574	42.284
03304	East Vine Street	5,000	7	GDLC	No	Kalamazoo	Kalamazoo	10	No	No	-85.566	42.284
03303	South Mill Street	7,004	7	GDLC	No	Kalamazoo	Kalamazoo	10	No	No	-85.567	42.284
05997	Breton Avenue	19,129	7	CSX	No	Kentwood	Kent	40	No	Yes	-85.608	42.910
02048	Tittabawassee Road	13,708	15	SBS	No	Kochville	Saginaw	25	No	Yes	-84.034	43.481
04517	Saint Joseph Street	5,125	7	NS	No	Lansing	Ingham	10	No	No	-84.582	42.727
01664	Main Street	2,375	7	NS	No	Lansing	Ingham	10	No	No	-84.582	42.726
05626	Morris Road	4,830	3	GTW	No	Lapeer	Lapeer	79	No	Yes	-83.285	43.046
02722	Champaigne Street	7,670	6	CRSH	No	Lincoln Park	Wayne	25	No	Yes	-83.192	42.247
04413	Levan Road	14,289	6	CSX	No	Livonia	Wayne	45	No	Yes	-83.402	42.376
06784	Morse Lake Road	781	12	CSX	No	Lowell	Kent	40	No	No	-85.410	42.863
04530	Segwun Avenue	16,170	20	GR	No	Lowell	Kent	20	No	Yes	-85.343	42.924
06621	North Street	2,100	5	NS	No	Mason	Ingham	10	No	No	-84.449	42.584
05740	East Elm Avenue	3,200	7	GTW	No	Monroe	Monroe	25	No	Yes	-83.380	41.913
05740	East Elm Avenue	3,200	7	NS	No	Monroe	Monroe	40	No	Yes	-83.380	41.913
13369	Western Avenue	3,927	5	CSX	No	Muskegon	Muskegon	10	No	No	-86.261	43.230
13372	7th Street	650	5	CSX	No	Muskegon	Muskegon	10	No	No	-86.259	43.233
13371	4th Street	85	5	CSX	No	Muskegon	Muskegon	10	No	No	-86.256	43.236
13370	Terrace Point Dr/Third St	324	5	CSX	No	Muskegon	Muskegon	10	No	No	-86.255	43.237
13443	Terrace Avenue	n/a	n/a	CSX	No	Muskegon	Muskegon	10	No	Yes	N/A	N/A
01772	Broadway Street	8,327	7	CSX	No	Muskegon Heights	Muskegon	10	No	No	-86.246	43.201
04736	Red Arrow Highway	7,481	n/a	COOK	No	N/A	Berrien	10	No	No	-86.543	41.977
03045	8th Street/US-31BL	8,349	5	CSX	No	N/A	Ottawa	35	No	No	-86.097	42.790
07132	New Haven Road	9,231	7	GTW	No	New Haven	Macomb	49	No	Yes	-82.801	42.729
00271	Seven Mile Road	16,446	7	CSX	No	Northville	Wayne	50	No	Yes	-83.473	42.424
01943	Joslyn Road	25,925	3	GTW	No	Orion	Oakland	25	No	No	-83.285	42.708
04899	11th Street	5,618	5	ATK	No	Oshkemo	Kalamazoo	79	No	Yes	-85.658	42.278
05202	Corunna Avenue/M-71	11,708	6	GLCR	No	Owosso	Shiawassee	20	No	No	-84.157	42.990

MDOT RR#	Intersecting Road Name	ADT	% Truck	RR Owner	MDOT Signal?	City/Township	County	RR Speed	Pedestrian Facilities?	Gates?	Long.	Lat.
05275	Washington Street	9,609	6	HSR	No	Owosso	Shiawassee	20	No	No	-84.171	42.993
04882	West River Road	17,020	7	CSX	No	Plainfield	Kent	25	No	Yes	-85.668	43.032
06989	Beck Road	29,343	7	CSX	No	Plymouth	Wayne	50	No	Yes	-83.510	42.386
03884	West Melody Lane	3,565	5	GDLK	No	Portage	Kalamazoo	40	No	No	-85.597	42.193
02132	West Centre Avenue	22,788	7	GDLK	No	Portage	Kalamazoo	40	No	No	-85.591	42.201
04366	Westmeige Street	7,585	9	GDLK	No	Portage	Kalamazoo	30	No	No	-85.590	42.203
02010	North Huron River Drive	14,158	7	NS	No	Rockwood	Wayne	50	No	Yes	-83.250	42.069
05372	Michigan Avenue	10,125	9	HSR	No	Saginaw	Saginaw	10	No	No	-83.976	43.408
04488	Fraser Street	4,600	7	HSR	No	Saginaw	Saginaw	10	No	No	-83.976	43.408
03108	West Genesee Street	14,475	8	HSR	No	Saginaw	Saginaw	25	No	No	-83.948	43.435
02293	Lawndale Road	3,867	9	SBS	No	Saginaw	Saginaw	25	No	Yes	-84.034	43.481
03475	Lake Street	12,819	7	CSX	No	South Lyon	Oakland	50	No	Yes	-83.646	42.461
04222	South Huron River Drive	10,000	7	NS	No	South Rockwood	Monroe	50	No	Yes	-83.256	42.062
03885	Northline Road	63,169	9	CRSH	No	Southgate	Wayne	50	No	Yes	-83.229	42.213
10287	Hiltop Road	8,591	7	CSX	No	St. Joseph	Berrien	65	No	Yes	-86.496	42.080
04169	Garfield Avenue	26,858	7	MDOT	No	Traverse City	Grand Traverse	20	No	No	-85.595	44.755
04126	Dobry Drive	14,301	0	CRSH	No	Utica	Macomb	0	No	No	-83.042	42.625
04127	Auburn Road	5,936	0	CRSH	No	Utica	Macomb	0	No	Yes	-83.042	42.626
03140	Hatchery Road	8,847	7	GTW	No	Waterford	Oakland	60	No	Yes	-83.372	42.679
04633	Williams Lake Road	21,409	9	GTW	No	Waterford	Oakland	60	No	Yes	-83.397	42.689
07373	Burkley Road	244	10	CSX	No	Williamston	Ingham	40	No	Yes	-84.342	42.688
00501	Wixom Road	24,752	10	CSX	No	Wixom	Oakland	40	No	No	-83.536	42.524
03402	Oak Street	7,370	6	CRSH	No	Wyandotte	Wayne	40	No	No	-83.161	42.204
03402	Oak Street	7,370	6	GTW	No	Wyandotte	Wayne	20	No	Yes	-83.160	42.204
03402	Oak Street	7,739	6	GTW	No	Wyandotte	Wayne	40	No	Yes	-83.162	42.204
02701	54th Street	41,661	7	GDLK	No	Wyoming	Kent	40	Yes	Yes	-85.674	42.866
00734	44th Street	29,314	9	GDLK	No	Wyoming	Kent	25	Yes	Yes	-85.675	42.884
03925	36th Street	29,769	7	GDLK	No	Wyoming	Kent	25	Yes	Yes	-85.675	42.899
04840	River Street	3,068	7	NS	No	Ypsilanti	Washtenaw	79	No	Yes	-83.609	42.246
04840	Cross Street	10,246	7	NS	No	Ypsilanti	Washtenaw	79	No	Yes	-83.609	42.246
04972	Leforge Street	9,494	5	NS	No	Ypsilanti	Washtenaw	79	No	Yes	-83.622	42.255
07230	Fairview Street	10,601	5	CSX	No	Zeeland	Ottawa	65	No	Yes	-86.000	42.818

**APPENDIX C. TEMPLATES FOR TRAFFIC SIGNAL TIMING AND
PHASING PLAN DESIGN**

Normal Operation:

The normal operation for this particular intersection may have any possible phasing design (e.g. permissive, protected/permissive, protected or split phasing etc.). A sample of phasing design during the Normal Operation is presented below.

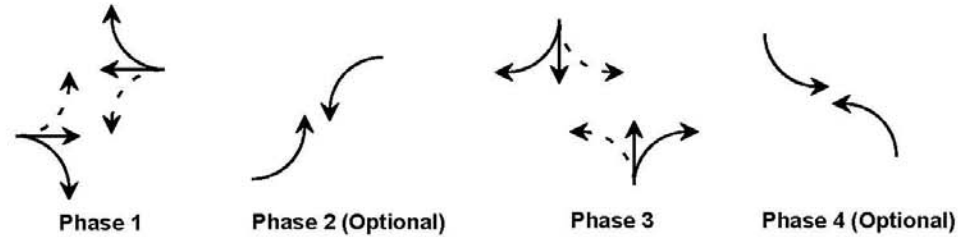

Preemption Design of Traffic Signal:

The preemption operation for such configuration (shown in the figure) consists of the following four steps irrespective of the normal operation phasing design.

i) Step 1, Right of Way Transfer:

Right of Way transfer function is initiated when the presence of an approaching train is detected.

Min Right of Way Transfer Time (RTT)= Max {(Flashing Don't Walk Interval+All Red), (Min Green (5.0 s) +Yellow+All Red)}

Flashing Don't Walk time is calculated as per MUTCD.

ii) Step 2, Track Clearance:

When the tracks cross in the middle of the intersection, no track clearance is required. The traffic signal has to indicate red for all the approaches. All movements are prohibited where RR crossing gates are present.

iii) Step 3, Holding Phase:

Holding phase consists of only those phases of the normal operation mode which can be allowed during the period when the railroad preemption warning devices are active. All Red should be indicated for all approaches in this particular case.

iv) Step 4, Return to Normal Operation:

Back to Normal Operation starts after the railroad preemption warning devices are deactivated. The priority should be given to the approaches where major traffic is located.

v) Recommendations:

- 1) Sign "R-10-11a" may be used in this particular intersection to prohibit right turning movements towards the tracks (where there are no gates).
- 2) Use 5.0 s as minimum green time for the right of way transfer phase in order to start the track clearance phase where there are no pedestrians expected.
- 3) The pedestrian walk intervals may be shortened or omitted in a rural intersection however, it must be used in case of urban intersections.

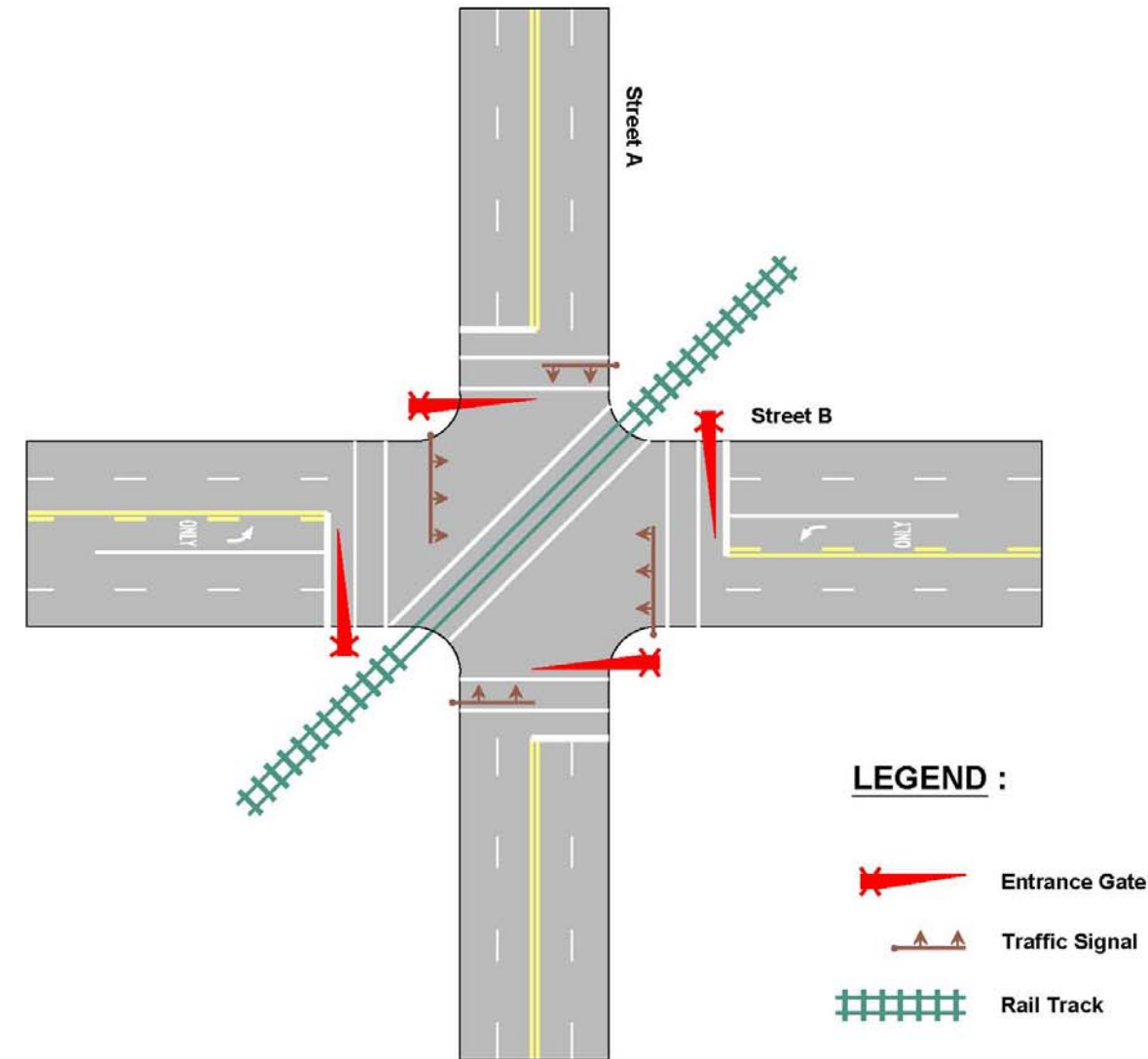

RAILROAD CROSSING THROUGH THE MIDDLE OF A NORMAL SIGNALIZED INTERSECTION

Timing Issues for Traffic Signals Interconnected with Highway-Railroad Grade Crossings

SCALE	DRAWN BY	REVIEWED BY	DATE	REVISION DATE	SHEET
NTS	AF/BR	TKD	04/04/12		Template-001

Normal Operation:

The normal operation for this particular intersection may have any possible phasing design (e.g. permissive, protected/permissive, protected or split phasing etc.). A sample of phasing design during the Normal Operation is presented below.

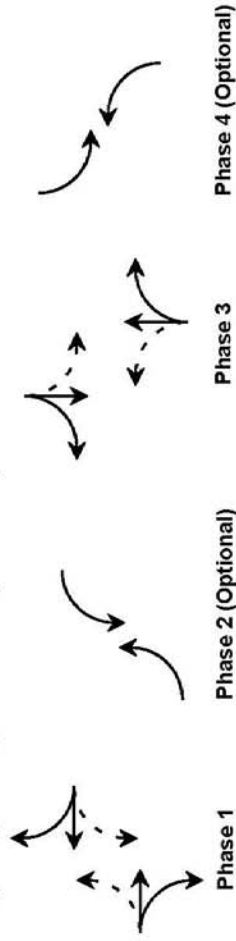

Preemption Design of Traffic Signal:

The preemption operation for such configuration (shown in the figure) consists of the following four steps irrespective of the normal operation phasing design.

- i) **Step 1, Right of Way Transfer:**
Right of Way transfer function is initiated when the presence of an approaching train is detected.
Min Right of Way Transfer Time (RTT)= Max {(Flashing Don't Walk Interval+All Red), (Min Green (5.0 s) +Yellow+All Red)}
Flashing Don't Walk time is calculated as per MUTCD.
- ii) **Step 2, Track Clearance:**
When the tracks cross in the middle of the intersection, no track clearance is required. The traffic signal has to indicate red for all the approaches. All movements are prohibited where RR crossing gates are present.
- iii) **Step 3, Holding Phase:**
Holding phase consists of only those phases of the normal operation mode which can be allowed during the period when the railroad preemption warning devices are active. All Red should be indicated for all approaches in this particular case.
Right and Left Turning movements from Street A and Street B can be allowed during Holding Phase as long as they do not encroach on the Train safety envelope.
- iv) **Step 4, Return to Normal Operation:**
Back to Normal Operation starts after the railroad preemption warning devices are deactivated. The priority should be given to the approaches where major traffic is located.

Recommendations:

- 1) Sign "R-10-11a" may be used in this particular intersection to prohibit right turning movements towards the tracks (where there are no gates).
- 2) Use 5.0 s as minimum green time for the right of way transfer phase in order to start the track clearance phase where there are no pedestrians expected.
- 3) The pedestrian walk intervals may be shortened or omitted in a rural intersection however, it must be used in case of urban intersections.

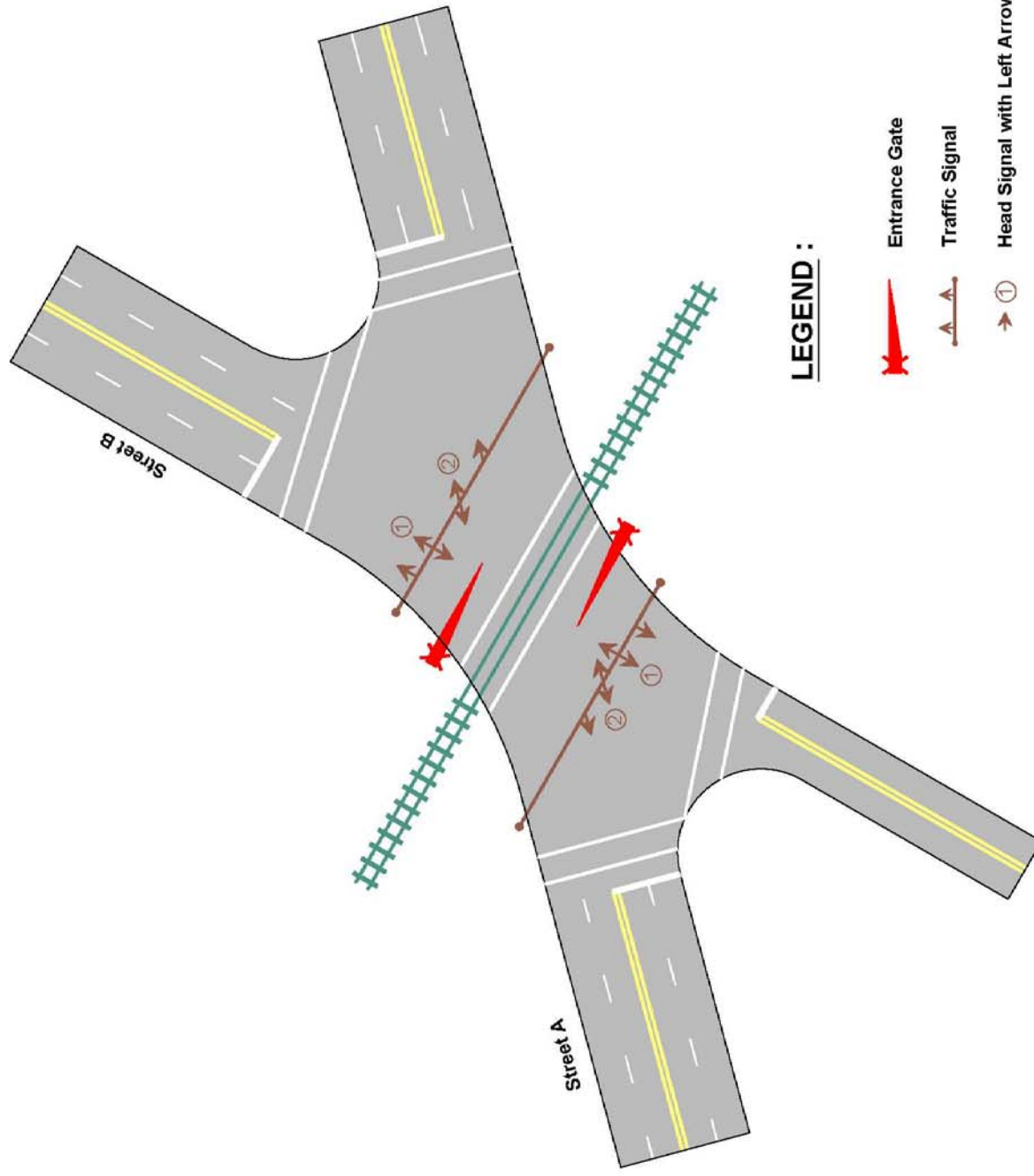

LEGEND :

- Entrance Gate
- Traffic Signal
- Head Signal with Left Arrow
- Head Signal with Right Arrow
- Rail Track

		Timing Issues for Traffic Signals Interconnected with Highway-Railroad Grade Crossings			
		SCALE	DRAWN BY	REVIEWED BY	DATE
		NTS	AF/BR	TKD	04/04/12
					REVISION DATE
					SHEET
					Template-002

Normal Operation

The most commonly used phasing design for this particular configuration (shown in the figure- direct left turn prohibited) consists of the following two phases with no left turning movements.

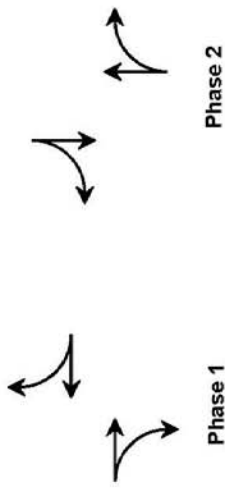

Preemption Design of Traffic Signal:

i) Step 1, Right of Way Transfer:

Right of Way transfer function is initiated when the presence of an approaching train is detected.

Min Right of Way Transfer Time (RTT) = Max {(Flashing Don't Walk Interval + All Red), (Min Green (5.0 s) + Yellow + All Red)}

Flashing Don't Walk time is calculated as per MUTCD.

ii) Step 2, Track Clearance:

Track Clearance phase consists of a split phase and the green time provided for this phase depends on the queue length. Table 1 shows the minimum green time values.

Table 1: Track Clearance Green Time (sec)

Clearance Distance L (ft)	Passenger & Heavy Vehicles	
	Passenger Vehicles	Heavy vehicles up to 10% Heavy vehicles > 10%
50	10.0	15.0
75	10.0	15.0
100	12.0	20.0
125	14.0	22.5
150	16.0	24.5
175	18.0	27.0
200	20.0	29.5
225	22.0	32.0
250	23.5	34.5
275	25.5	37.0
300	27.0	39.5
325	29.0	42.0
350	31.0	44.5
375	32.5	47.0
400	34.5	49.0
		50.0

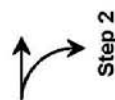

Step 2
 Green Time = Refer to Table 1
 Yellow Time = $t + V / (2a + 64.4g)$
 All Red Time = $(W + L) / V$

Track Clearance distance (L) is the space between the nearest edge of the cross street to the far side gate or the flasher location.

iii) Step 3, Holding Phase:

Holding phase for this particular intersection includes the following directions/phases of the normal operation and is continued until the railroad preemption warning is deactivated.

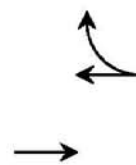

Step 3

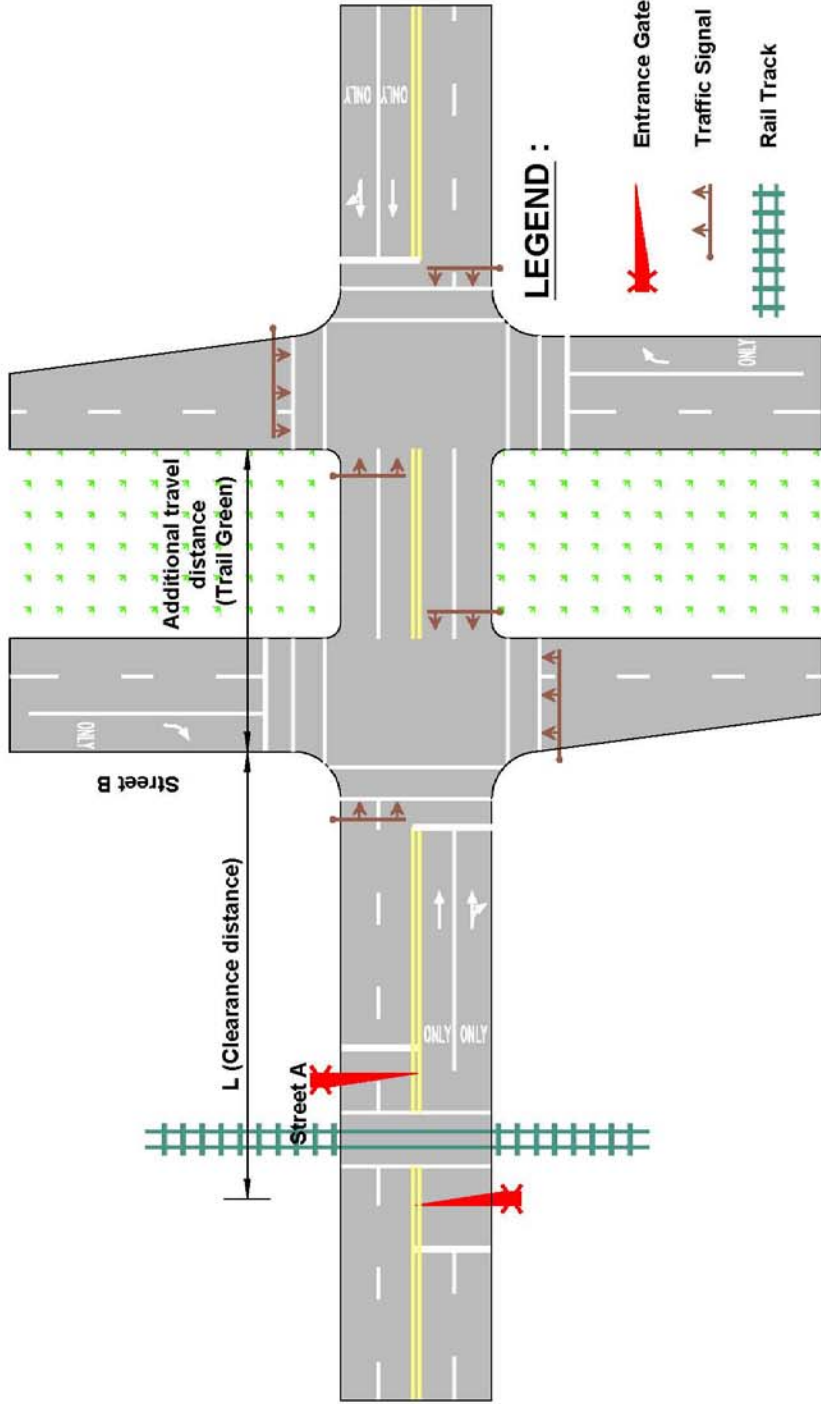

iv) Step 4, Return to Normal Operation:

Back to Normal Operation starts after the railroad preemption warning is discontinued. The priority should be given to the approach where the railroad crossing is located.

v) Recommendations:

- 1) In order to prohibit the right and left turning movements towards the tracks during preemption, a blank-out or changeable message sign (sign R3-1a or R3-2a) may be used for this particular type of intersection.
- 2) Minimum green time for the right of way transfer phase is recommended as 5.0 s where there are no pedestrians expected.
- 3) The pedestrian walk intervals may be shortened or omitted in a rural intersection however, it must be used in case of urban intersections.



R3-1a



R3-2a



**RAILROAD CROSSING
 NEAR A SIGNALIZED BOULEVARD
 INTERSECTION**

Timing Issues for Traffic Signals Interconnected with Highway-Railroad Grade Crossings

SCALE	DRAWN BY	REVIEWED BY	DATE	REVISION DATE	SHEET
NTS	AF/BR	TKD	04/04/12		Template-003

Normal Operation:

The normal operation for this particular intersection may have any possible phasing design (e.g. permissive, protected/permissive, split phasing etc.). A sample of phasing design during the Normal Operation is presented below.

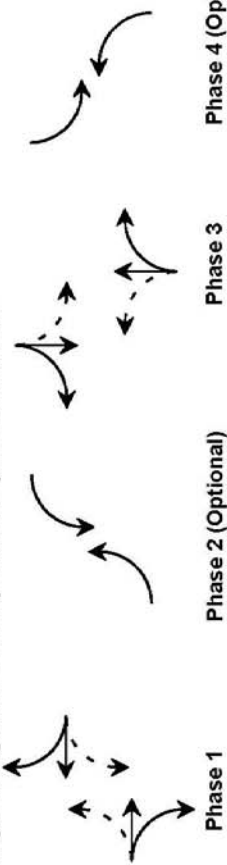

Preemption Design of Traffic Signal:

The recommended preemption operation for this particular type of intersection consists of the following four steps irrespective of the phasing design during normal operation.

- i) **Step 1, Right of Way Transfer:**
Right of Way transfer function is initiated when the presence of an approaching train is detected.
Min Right of Way Transfer Time (RTT) = Max {(Flashing Don't Walk Interval+All Red), (Min Green (5.0 s) +Yellow+All Red)}
Flashing Don't Walk time is calculated as per MUTCD.
- ii) **Step 2 and 3, Track Clearance:**
Track Clearance phase consists of two split phases shown as step 2 & 3 below. The priority should be given to that direction which is expected to have longer queue. The required track clearance green time can be determined using Table 1.



Step 2

Green Time = Refer to Table 1
Yellow Time = $t + v / (2a + 64.4g)$
All Red Time = $(W + L) / V$

Track Clearance distance (L) is the space between the nearest edge of the cross street to the far side gate or the flasher location.

- iii) **Step 4, Holding Phase:**
Holding phase should allow these two traffic movements shown as step 4 which can continue as long as the railroad preemption warning devices are active.

Step 4

Table 1: Track Clearance Green Time (sec)

Clearance Distance L (ft)	Passenger & Heavy Vehicles	
	Passenger Vehicles	Heavy vehicles up to 10% Heavy vehicles > 10%
50	10.0	15.0
75	10.0	15.0
100	12.0	20.0
125	14.0	22.5
150	16.0	24.5
175	18.0	27.0
200	20.0	29.5
225	22.0	32.0
250	23.5	34.5
275	25.5	37.0
300	27.0	39.5
325	29.0	42.0
350	31.0	44.5
375	32.5	47.0
400	34.5	49.0
		50.0

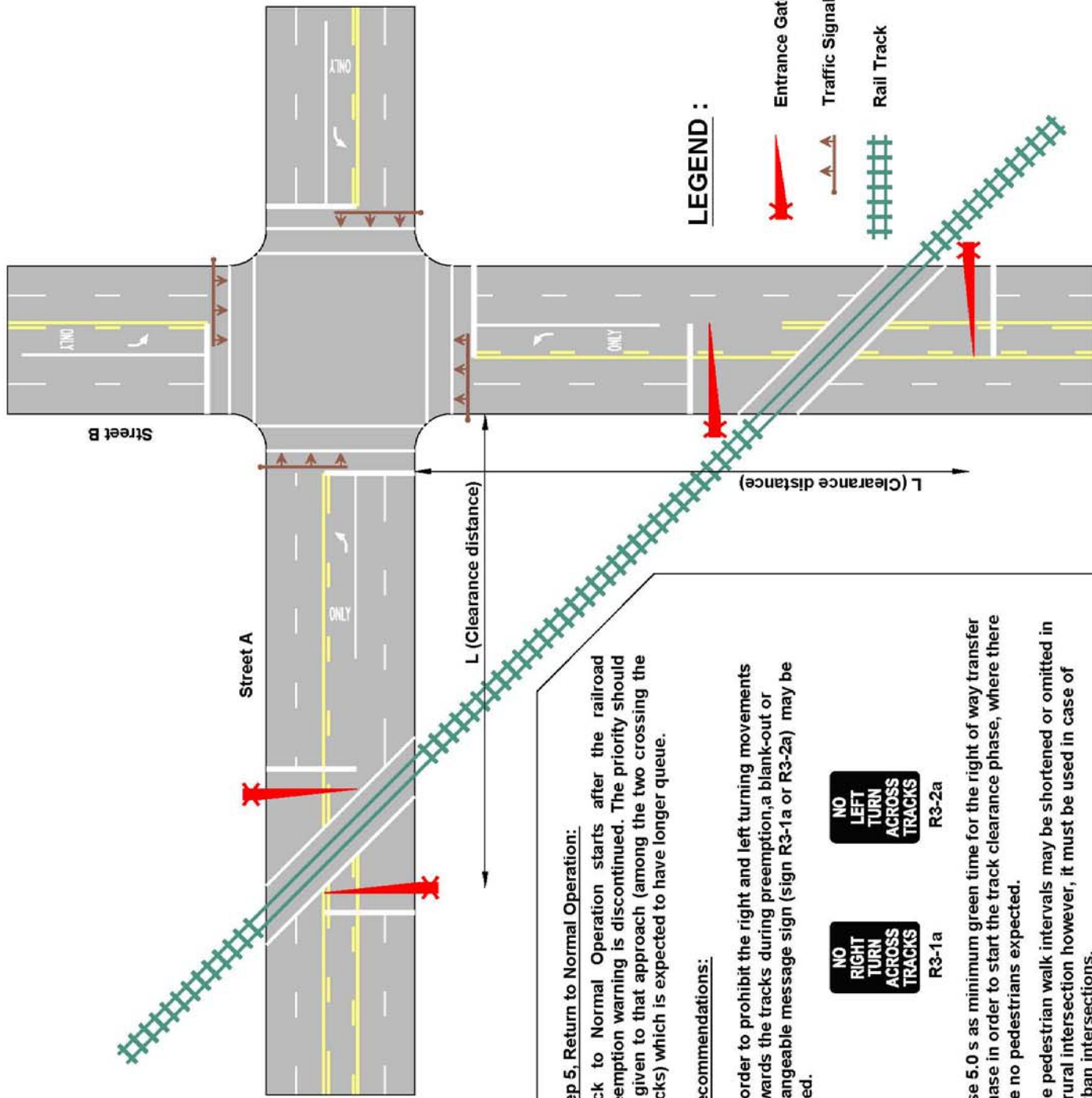

iv) Step 5, Return to Normal Operation:

Back to Normal Operation starts after the railroad preemption warning is discontinued. The priority should be given to that approach (among the two crossing the tracks) which is expected to have longer queue.

v) Recommendations:

- 1) In order to prohibit the right and left turning movements towards the tracks during preemption, a blank-out or changeable message sign (sign R3-1a or R3-2a) may be used.
 - NO RIGHT TURN ACROSS TRACKS R3-1a**
 - NO LEFT TURN ACROSS TRACKS R3-2a**
- 2) Use 5.0 s as minimum green time for the right of way transfer phase in order to start the track clearance phase, where there are no pedestrians expected.
- 3) The pedestrian walk intervals may be shortened or omitted in a rural intersection however, it must be used in case of urban intersections.



SKewed RAILROAD CROSSING TWO APPROACHES NEAR A SIGNALIZED INTERSECTION

Timing Issues for Traffic Signals Interconnected with Highway-Railroad Grade Crossings

SCALE	DRAWN BY	REVIEWED BY	DATE	REVISION DATE	SHEET
N/T/S	AF/BR	TKD	04/04/12		Template-004

Normal Operation:

The most commonly used phasing design during the normal operation of this particular intersection consists of the following two phases as shown below.

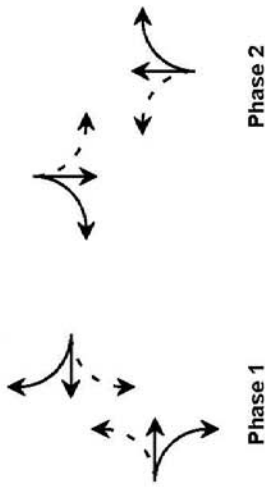

Preemption Design of Traffic Signal:

i) **Step 1, Right of Way Transfer:**

Right of Way transfer function is initiated when the presence of an approaching train is detected.

Min Right of Way Transfer Time (RTT) = Max {(Flashing Don't Walk Interval + All Red), (Min Green (5.0 s) + Yellow + All Red)}

Flashing Don't Walk time is calculated as per MUTCD.

ii) **Step 2, Track Clearance:**

Track Clearance phase consists of a split phase shown in the phasing diagram below. The minimum track clearance green time depends on the queue length and can be determined using the values provided in Table 1.



Step 2
Green Time = Refer to Table 1
Yellow Time = $t + V / (2a + 64.4g)$
All Red Time = $(W + L) / V$

Track Clearance distance (L) is the space between the nearest edge of the cross street to the far side gate or the flasher location.

iii) **Step 3, Holding Phase:**

Holding phase should allow the following traffic movements which can continue as long as the railroad preemption warning devices are active.

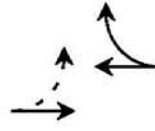

Step 3

Table 1: Track Clearance Green Time (sec)

Clearance Distance L (ft)	Passenger & Heavy Vehicles	
	Passenger Vehicles	Heavy vehicles up to 10% Heavy vehicles > 10%
50	10.0	15.0
75	10.0	15.0
100	12.0	20.0
125	14.0	22.5
150	16.0	24.5
175	18.0	27.0
200	20.0	29.5
225	22.0	32.0
250	23.5	34.5
275	25.5	37.0
300	27.0	39.5
325	29.0	42.0
350	31.0	44.5
375	32.5	47.0
400	34.5	49.0
		50.0

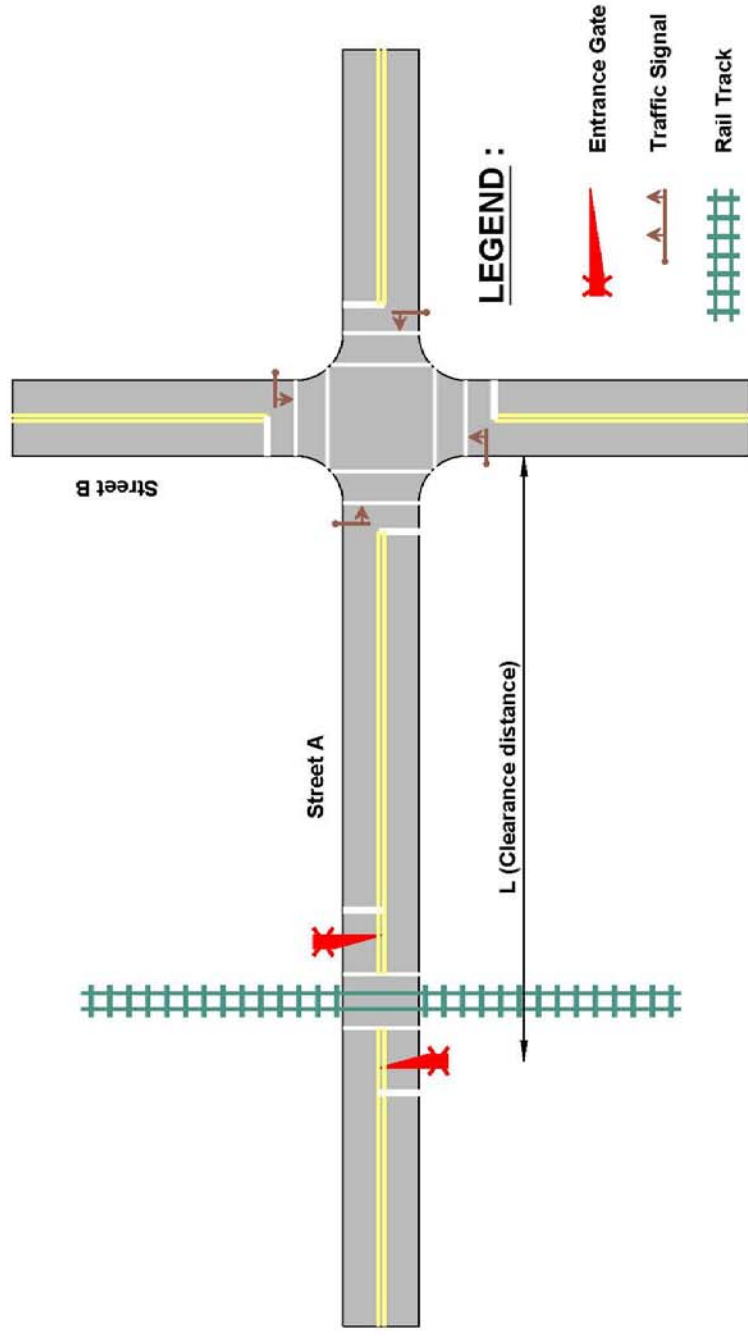

iv) **Step 4, Return to Normal Operation:**

Back to Normal Operation starts after the railroad preemption warning devices are deactivated. The priority should be given to the approach where the railroad crossing is located.

iv) **Recommendations:**

1) In order to prohibit the right and left turning movements towards the tracks during preemption, a blank-out or changeable message sign (sign R3-1a or R3-2a) may be used.



2) Use 5.0 s as minimum green time for the right of way transfer in order to start the track clearance phase, where there are no pedestrians expected.

3) The pedestrian walk intervals may be shortened or omitted in a rural intersection however, it must be used in case of urban intersections.

Note:

The same template is applicable if the rail tracks are located on any leg of this particular type of intersection.



RAILROAD CROSSING ON A TWO LANE ROADWAY NEAR A SIGNALIZED INTERSECTION

Timing Issues for Traffic Signals Interconnected with Highway-Railroad Grade Crossings

SCALE	DRAWN BY	REVIEWED BY	DATE	REVISION DATE	SHEET
NTS	AF/BR	TKD	04/04/12		Template-005

Normal Operation:

The normal operation for this particular intersection may have any possible phasing design (e.g. permissive, protected/permissive, protected or split phasing). A sample of phasing design during the Normal Operation is presented below.

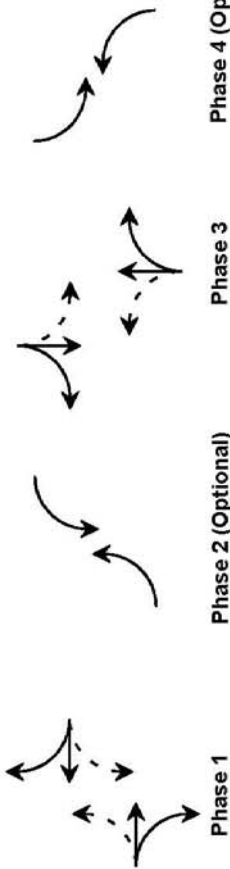

Preemption Design of Traffic Signal:

The preemption operation for this particular intersection consists of the following four steps irrespective of the phasing design during normal operation.

i) Step 1, Right of Way Transfer:

Right of Way transfer function is initiated when the presence of an approaching train is detected.

Min Right of Way Transfer Time (RTT) = Max {(Flashing Don't Walk Interval + All Red), (Min Green (5.0 s) + Yellow + All Red)}

Flashing Don't Walk time is calculated as per MUTCD.

ii) Step 2, Track Clearance:

Track Clearance phase consists of a split phase shown as step 2 below. The minimum track clearance green time depends on the queue length and can be determined using the values provided in Table 1.



Step 2

Green Time = Refer to Table 1
 Yellow Time = $t + \sqrt{(2a + 64.4g)}$
 All Red Time = $(W + L) / V$

Track Clearance distance (L) is the space between the nearest edge of the cross street to the far side gate or the flasher location.

iii) Step 3, Holding Phase:

Holding phase should allow the following traffic movements which can continue as long as the railroad preemption warning devices are active.



Step 3

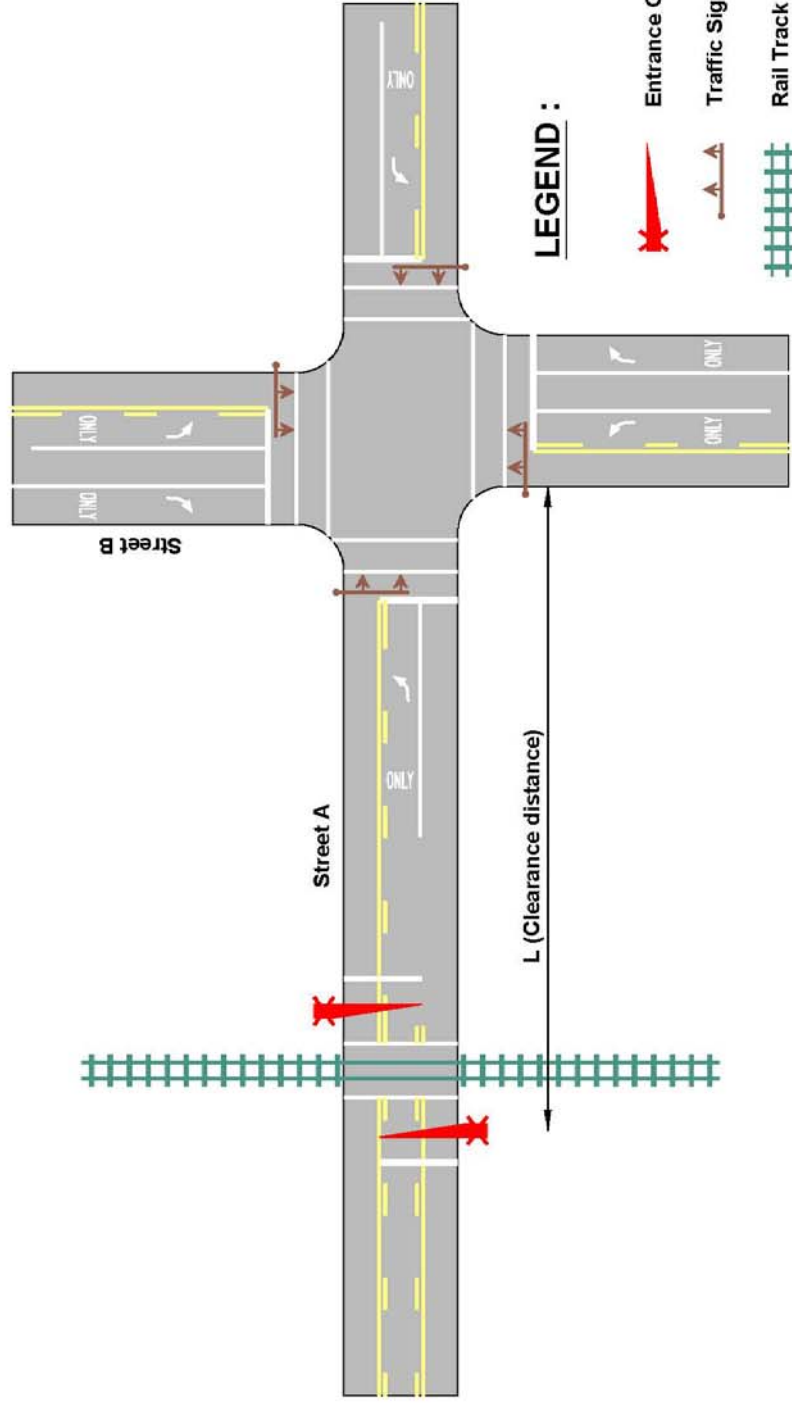

LEGEND :

- Entrance Gate
- Traffic Signal
- Rail Track

iv) Step 4, Return to Normal Operation:

Back to Normal Operation starts after the railroad warning devices are deactivated. The priority should be given to the approach where the railroad crossing is located.

v) Recommendations:

1) In order to prohibit the right and left turning movements towards the tracks during preemption, a blank-out or changeable message sign (sign R3-1a or R3-2a) or left and right turn arrow head signals may be used for this particular type of intersection.

2) Use 5.0 s as minimum green time for the right of way transfer phase in order to start the track clearance phase where there are no pedestrians expected.

3) The pedestrian walk intervals may be shortened or omitted in a rural intersection however, it must be used in case of urban intersections.



Note:

The same template can be used in case the rail tracks are located on the other street of the shown intersection which has exclusive right turn lane. However, in that case right turn arrow head signal can not be used to prohibit the right turning movements towards the tracks.

Table 1: Track Clearance Green Time (sec)

Clearance Distance L (ft)	Passenger & Heavy Vehicles	
	Passenger Vehicles	Heavy Vehicles up to 10% > 10%
50	10.0	15.0
75	10.0	15.0
100	12.0	20.0
125	14.0	22.5
150	16.0	24.5
175	18.0	27.0
200	20.0	29.5
225	22.0	32.0
250	23.5	34.5
275	25.5	37.0
300	27.0	39.5
325	29.0	42.0
350	31.0	44.5
375	32.5	47.0
400	34.5	49.0
		50.0



RAILROAD CROSSING NEAR A SIGNALIZED INTERSECTION WITH AN EXCLUSIVE LEFT TURN LANE ON THE CRITICAL APPROACH

Timing Issues for Traffic Signals Interconnected with Highway-Railroad Grade Crossings

SCALE	DRAWN BY	REVIEWED BY	DATE	REVISION DATE	SHEET
NTS	AF/BR	TKD	04/04/12		Template-006

Normal Operation:

A sample of phasing design during the normal operation of this particular intersection is presented below.

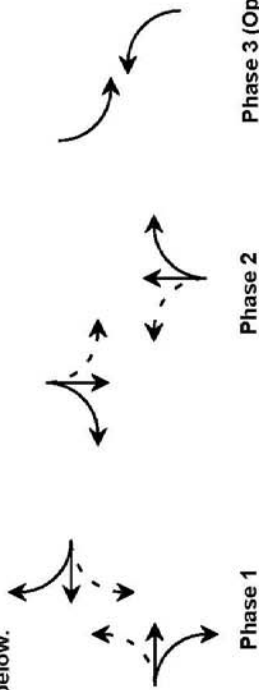

Preemption Design of Traffic Signal:

The recommended preemption operation for this particular intersection consists of the following four steps irrespective of the phasing design during normal operation.

- i) **Step 1, Right of Way Transfer:**
Right of Way transfer function is initiated when the presence of an approaching train is detected.
Min Right of Way Transfer Time (RTT) = Max {(Flashing Don't Walk Interval + All Red), (Min Green (5.0 s) + Yellow + All Red)}
Flashing Don't Walk time is calculated as per MUTCD.
- ii) **Step 2, Track Clearance:**
Track Clearance phase consists of a split phase shown as step 2 below. The minimum track clearance green time depends on the queue length and can be determined using the values provided in Table 1.

Step 1
Green Time = Refer to Table 1
Yellow Time = $t + v / (2a + 64.4g)$
All Red Time = $(W + L) / V$

Step 2
Track Clearance distance (L) is the space between the nearest edge of the cross street to the far side gate or the flasher location.

Step 3, Holding Phase:
Holding phase for this particular intersection should allow the following traffic movements which can continue as long as the railroad preemption warning devices are active.

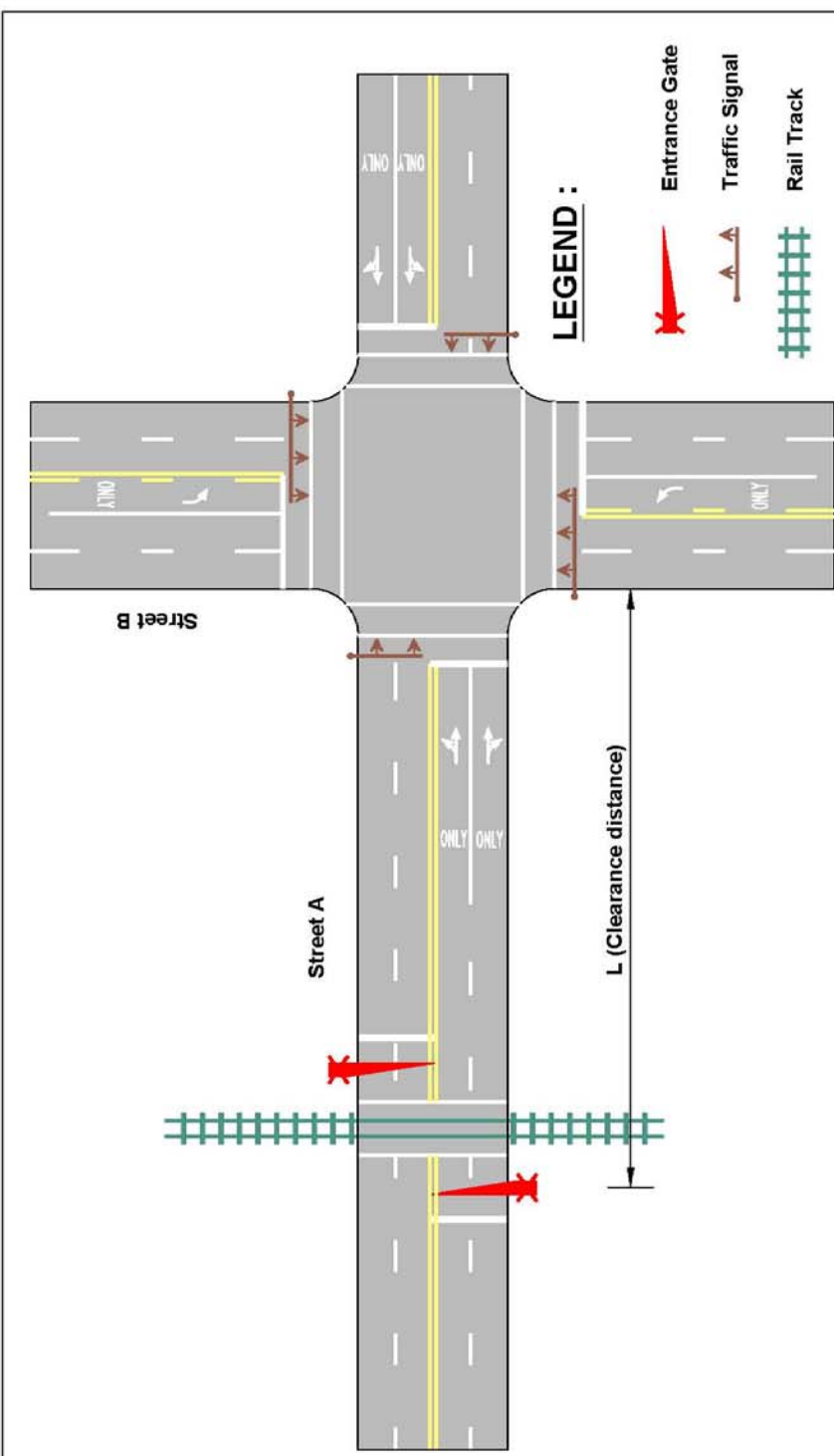
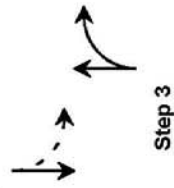

iv) Step 4, Return to Normal Operation:

Back to Normal Operation starts after the railroad preemption warning devices are deactivated. The priority should be given to the approach where the railroad crossing is located.

v) Recommendations:

- 1) In order to prohibit the right and left turning movements towards the tracks during preemption, a blank-out or changeable message sign (sign R3-1a or R3-2a) may be used. Left turn signal head may also be used for this particular type of intersection to prohibit left turning movements towards the tracks.
- 2) Use 5.0 s as minimum green time for the right of way transfer phase in order to start the track clearance phase where there are no pedestrians expected.
- 3) The pedestrian walk intervals may be shortened or omitted in a rural intersection however, it must be used in case of urban intersections.

Note:

In case the tracks are located on the other street of the shown intersection, left turn head signal can not be used to prohibit left turning movements towards the tracks.



Table 1: Track Clearance Green Time (sec)

Clearance Distance L (ft)	Passenger Vehicles	Passenger & Heavy Vehicles	
		Heavy vehicles up to 10%	Heavy vehicles > 10%
50	10.0	15.0	15.0
75	10.0	15.0	15.0
100	12.0	20.0	20.0
125	14.0	22.5	24.5
150	16.0	24.5	26.5
175	18.0	27.0	29.0
200	20.0	29.5	31.5
225	22.0	32.0	34.0
250	23.5	34.5	36.0
275	25.5	37.0	38.5
300	27.0	39.5	41.0
325	29.0	42.0	43.0
350	31.0	44.5	45.5
375	32.5	47.0	48.0
400	34.5	49.0	50.0



RAILROAD CROSSING ON A FOUR LANE ROADWAY NEAR A SIGNALIZED INTERSECTION

Timing Issues for Traffic Signals Interconnected with Highway-Railroad Grade Crossings

SCALE	DRAWN BY	REVIEWED BY	DATE	REVISION DATE	SHEET
NTS	AF/BR	TKD	04/04/12		Template-007