

**NOTE:**

CENTER SIGN VERTICALLY ON CANTILEVER ARMS

**NOTES:**

1. THE DESIGN OF THIS STRUCTURE IS BASED ON THE AASHTO LRFD SPECIFICATIONS FOR STRUCTURAL SUPPORTS FOR HIGHWAY SIGNS, LUMINAIRES AND TRAFFIC SIGNALS, 1ST EDITION, WITH INTERIM REVISIONS THROUGH 2022.
2. WELDING MUST BE IN ACCORDANCE WITH AWS D1.1 AS SPECIFIED IN 20SP-707A, STRUCTURAL STEEL AND ALUMINUM CONSTRUCTION.
3. MAXIMUM SIGN AREA IS 240 SQUARE FEET FOR ONE SIGN. MINIMUM SIGN HEIGHT WITH ALUMINUM BEAM IS 6.5 FEET.
4. GALVANIZING OF BOLT ASSEMBLIES SHALL BE IN ACCORDANCE WITH SUBSECTIONS 919.07.1 AND 906.07 OF THE MDOT STANDARD SPECIFICATIONS FOR CONSTRUCTION.
5. PROVIDE 1 1/16" Ø HOLES FOR 1" Ø HIGH STRENGTH (HS) BOLTS FOR ALL CONNECTIONS UNLESS OTHERWISE STATED. PROVIDE HIGH STRENGTH BOLTS, NUTS, AND WASHERS IN ACCORDANCE WITH SUBSECTION 906.07 OF THE MDOT STANDARD SPECIFICATIONS FOR CONSTRUCTION.
6. TIGHTEN ALL HIGH STRENGTH BOLTS BY THE TURN OF NUT METHOD PER SUBSECTION 707.03.E OF THE MDOT STANDARD SPECIFICATIONS FOR CONSTRUCTION.
7. ALL WELDS MUST BE INSPECTED IN ACCORDANCE WITH SUBSECTION 707.03.D.12 OF THE STANDARD SPECIFICATIONS FOR CONSTRUCTION, EXCEPT MINIMUM MT INSPECTION FREQUENCY IS INCREASED TO 25 PERCENT.
8. SEE CURRENT MDOT SIGN SUPPORT TYPICAL PLAN SIGN-340-SERIES FOR SIGN FOUNDATION.
9. SEE CURRENT MDOT SIGN SUPPORT TYPICAL PLAN SIGN-700-SERIES FOR SIGN CONNECTION.
10. COLUMN SECTIONS AND ARM SECTIONS MATERIALS MUST BE PROVIDED IN ACCORDANCE WITH SUBSECTION 919.07 OF THE MDOT STANDARD OF SPECIFICATIONS FOR CONSTRUCTION.
11. THE FLANGE PLATES MUST BE WELDED TO ASSURE OBTAINING FULL CONTACT IN THE RELAXED POSITION PRIOR TO SNUGGING UP FLANGE BOLTS. THE FLANGE BOLTS MUST NOT BE TORQUED IN AN ATTEMPT TO CLOSE.
12. BASE PLATE (P) WARPAGE MUST NOT EXCEED 1/16 INCH PER FOOT.
13. CJP WELDS ON OPTIONAL ARM SPLICES SHALL BE GROUND SMOOTH. ANY GRINDING OF WELDS IS TO BE DONE PRIOR TO GALVANIZATION. WELDING SHALL BE IN ACCORDANCE WITH SECTION 707 OF THE STANDARD SPECIFICATIONS FOR CONSTRUCTION.
14. SELECT SEALANT FOR PERIMETER OF BACKING BAR PLATE FROM THE QUALIFIED PRODUCTS LIST. PROVIDE SEALANT IN CAULKING TUBES.
15. CHARPY V-NOTCH TESTING IS REQUIRED FOR THE COLUMN UPRIGHT IN ACCORDANCE WITH THE AASHTO LRFD SPECIFICATIONS FOR STRUCTURAL SUPPORTS FOR HIGHWAY SIGNS, LUMINAIRES, AND TRAFFIC SIGNALS, 1ST EDITION, WITH INTERIM REVISIONS THROUGH 2022.

NOT TO SCALE

|   |   |   |                       |            |
|---|---|---|-----------------------|------------|
| <br>PREPARED BY<br>ANCILLARY<br>STRUCTURES<br>DRAWN BY: <u>HNTB</u><br>CHECKED BY: <u>MLD</u> | DEPARTMENT DIRECTOR<br>Bradley C. Wieferich, P.E.<br><br>APPROVED BY: _____<br>DIRECTOR, BUREAU OF FIELD SERVICES | MICHIGAN DEPARTMENT OF TRANSPORTATION<br><br><b>STEEL CANTILEVER<br/>TYPE E</b> |                       |            |
|   | APPROVED BY: _____<br>DIRECTOR, BUREAU OF DEVELOPMENT   | (SPECIAL DETAIL)<br>F.H.W.A. APPROVAL   | 08/08/23<br>PLAN DATE | SIGN-300-D |

|                                       |                                       |                       |            |                 |
|---------------------------------------|---------------------------------------|-----------------------|------------|-----------------|
| MICHIGAN DEPARTMENT OF TRANSPORTATION | (SPECIAL DETAIL)<br>F.H.W.A. APPROVAL | 08/08/23<br>PLAN DATE | SIGN-300-D | SHEET<br>2 OF 6 |
|---------------------------------------|---------------------------------------|-----------------------|------------|-----------------|



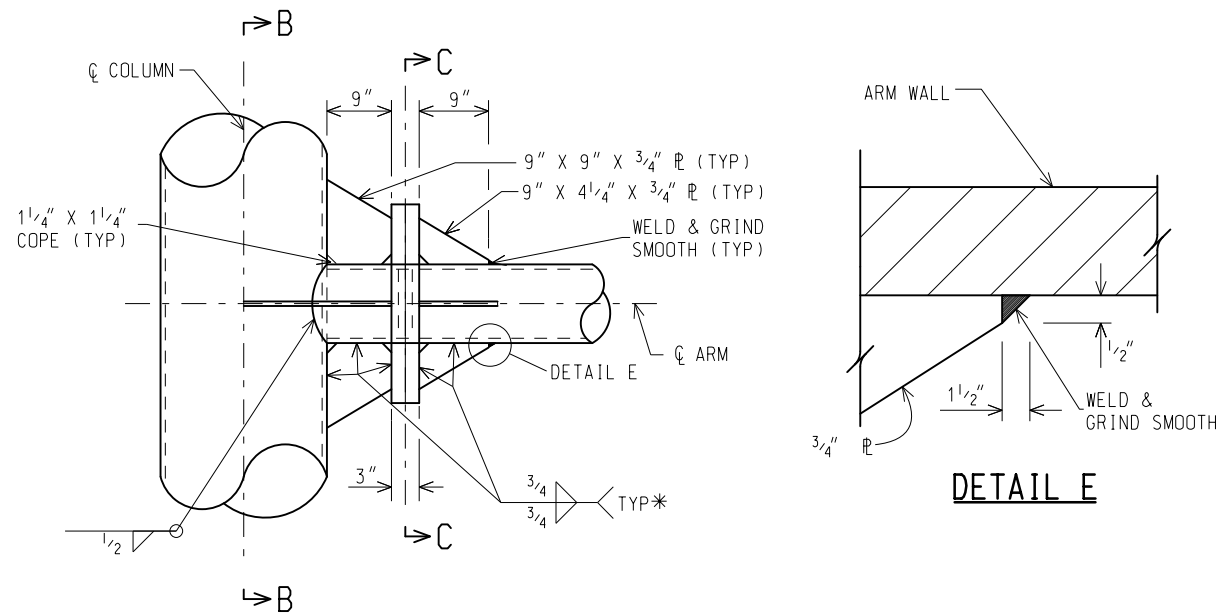

**DETAIL C - FRONT**

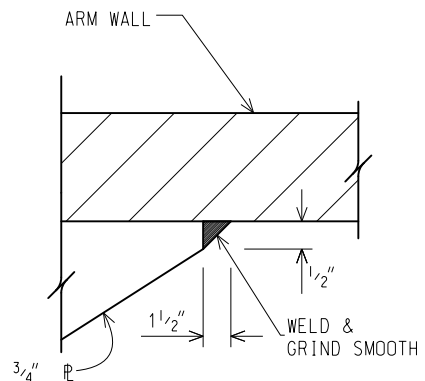

**DETAIL E**

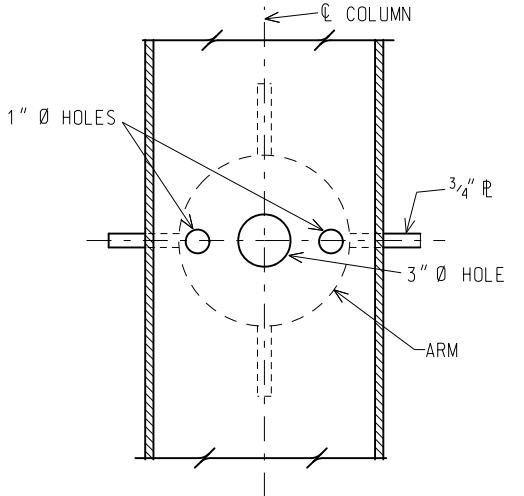

**SECTION B-B**

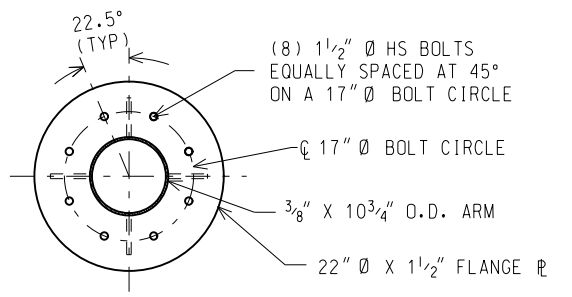

**SECTION C-C**

SEE SHEET 6 FOR ADDITIONAL FLANGE INFORMATION AND WASHER PLACEMENT

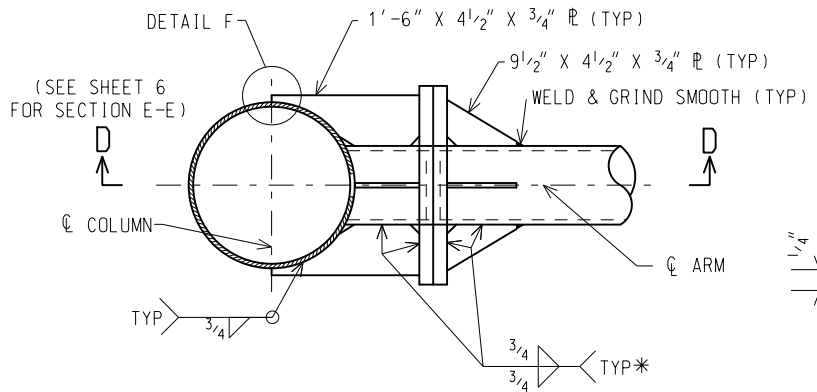

**DETAIL C - TOP**

**ARM CONNECTION**

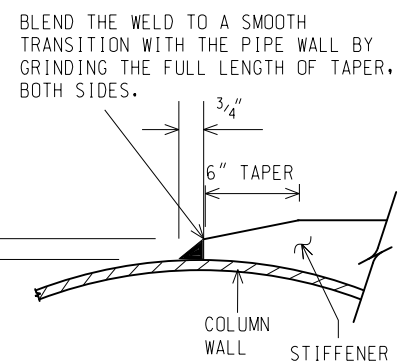

**DETAIL F**

BLEND THE WELD TO A SMOOTH TRANSITION WITH THE PIPE WALL BY GRINDING THE FULL LENGTH OF TAPER, BOTH SIDES.

\*WRAP WELD AROUND OUTSIDE EDGE, STOP 1/4" SHORT OF CORNER CLIP

NOT TO SCALE

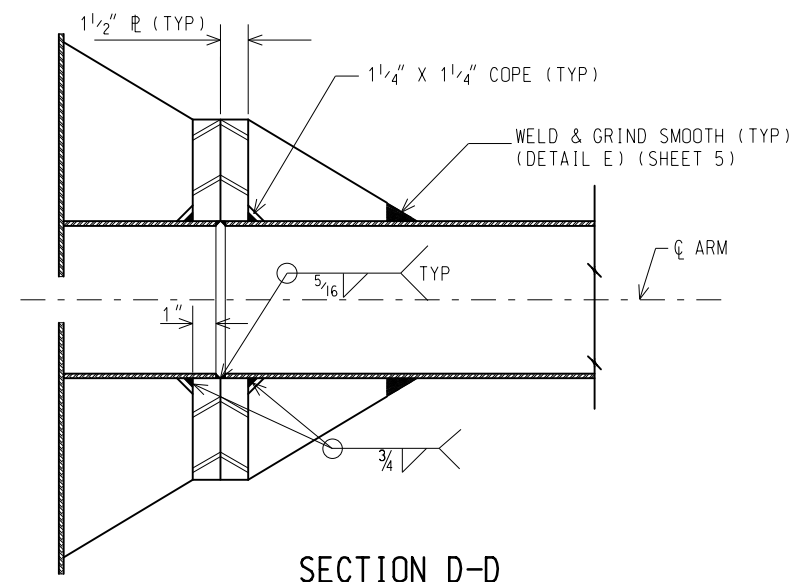

**SECTION D-D**

**ARM CONNECTION**

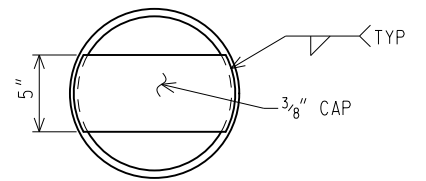

**END CAP DETAIL**

(USE AT THE END OF EACH ARM)

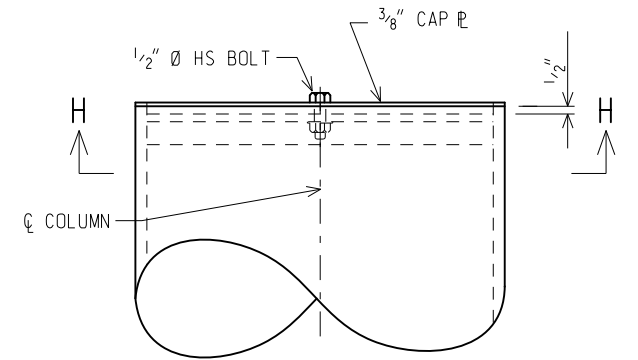

**COLUMN CAP DETAIL**

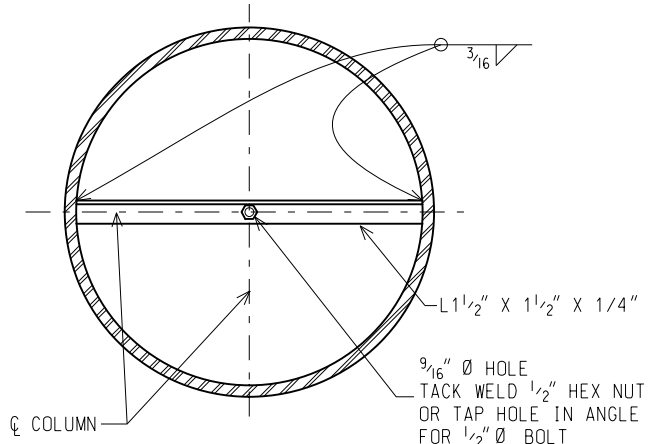

**SECTION H-H**

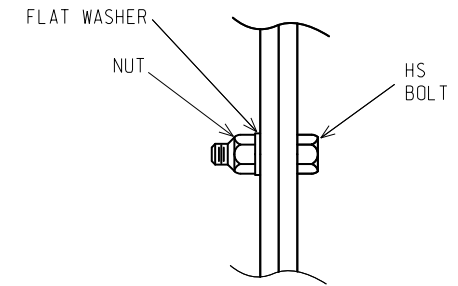

**DETAIL OF WASHER PLACEMENT**

NOT TO SCALE