

<p>PREPARED BY ANCILLARY STRUCTURES</p> <p>DRAWN BY: HNTB</p> <p>CHECKED BY: MLD</p>	<p>DEPARTMENT DIRECTOR Bradley C. Wiefelich, P.E.</p> <p>APPROVED BY: _____ DIRECTOR, BUREAU OF FIELD SERVICES</p>	<p>MICHIGAN DEPARTMENT OF TRANSPORTATION</p> <p><b>BRIDGE SIGN CONNECTION TYPE A1, A2 &amp; B</b></p>		
	<p>APPROVED BY: _____ DIRECTOR, BUREAU OF DEVELOPMENT</p>	<p>(SPECIAL DETAIL) F.H.W.A. APPROVAL</p>	<p>08/08/23 PLAN DATE</p>	<p>SIGN-800-B</p>

MICHIGAN DEPARTMENT OF TRANSPORTATION		(SPECIAL DETAIL) F.H.W.A. APPROVAL	08/08/23 PLAN DATE	SIGN-800-B	SHEET 2 OF 12
---------------------------------------	--	---------------------------------------	-----------------------	------------	------------------

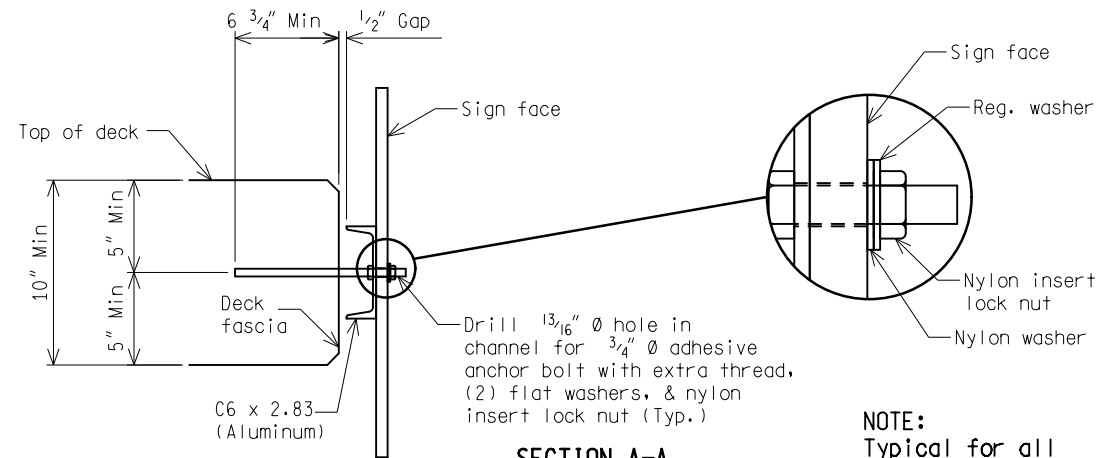

**SECTION A-A**

**NOTE:**  
Typical for all sign connections.

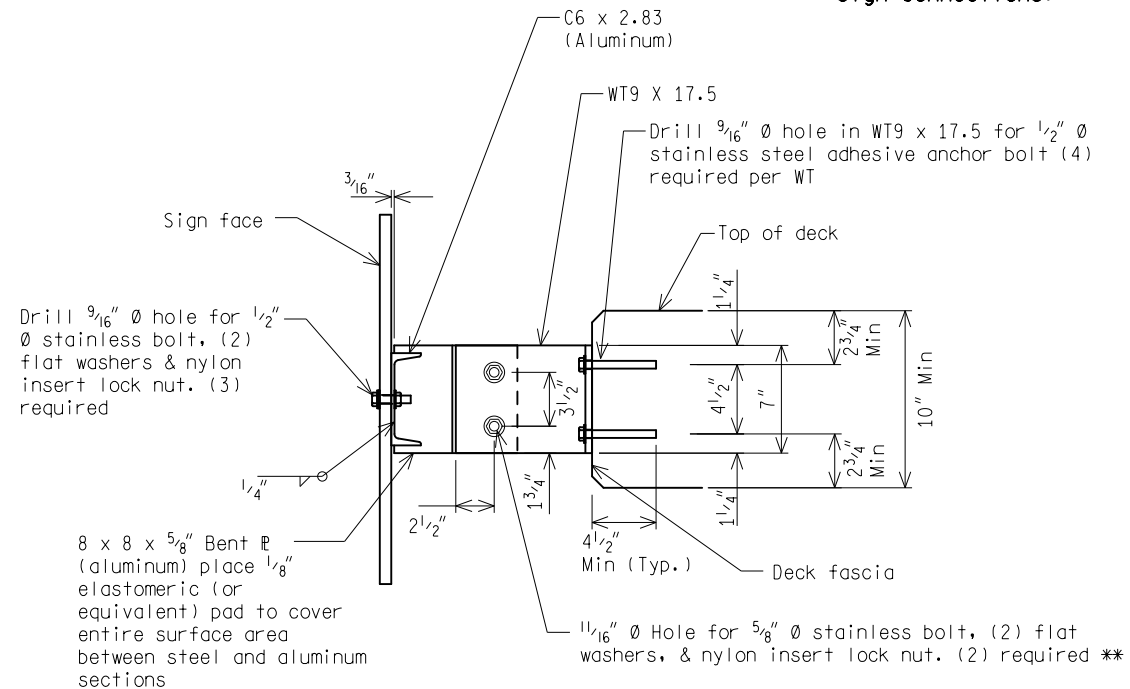

**SECTION B-B**

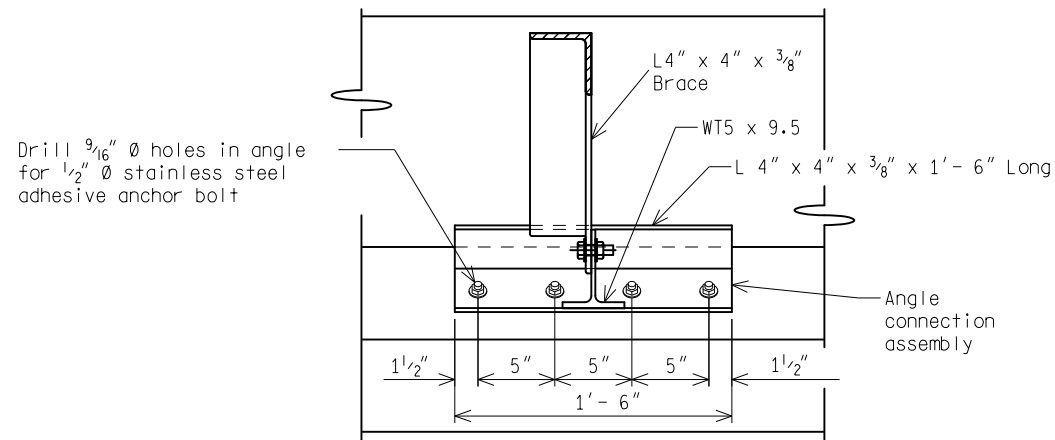

**SECTION D-D**

**BRIDGE CONNECTION - TYPE A1**

\*\* See Pg 10 of 12 for bolt detail

NOT TO SCALE

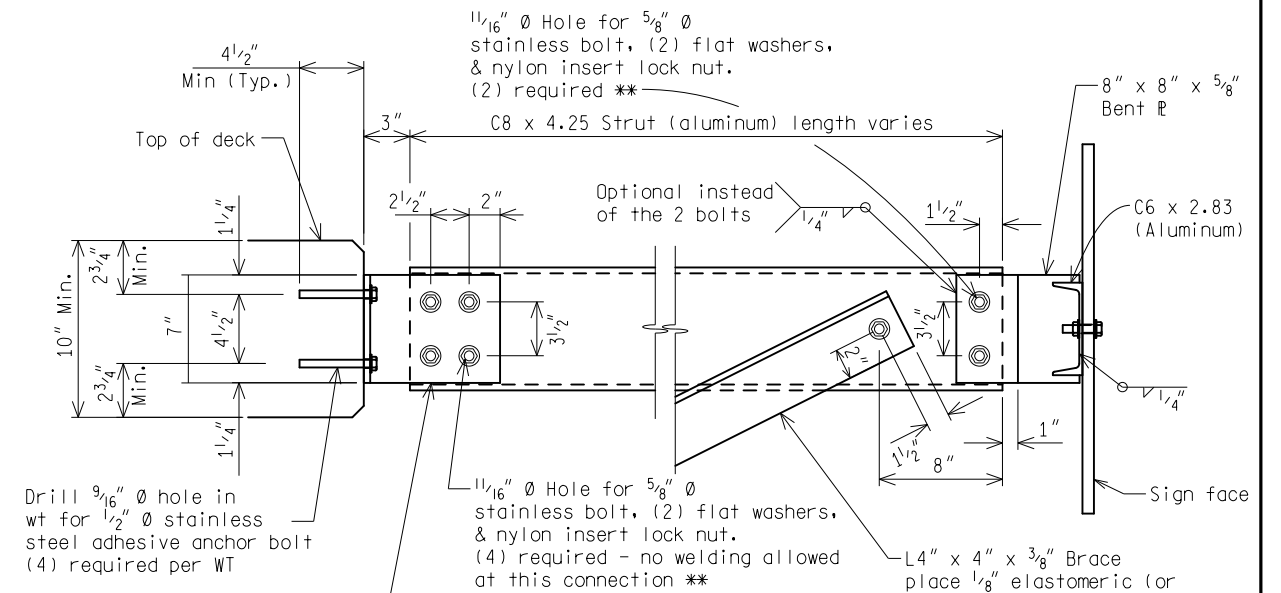

**SECTION C-C**

WT9 x 17.5 Place 1/8" elastomeric (or equivalent) pad to cover entire surface area between steel and aluminum sections

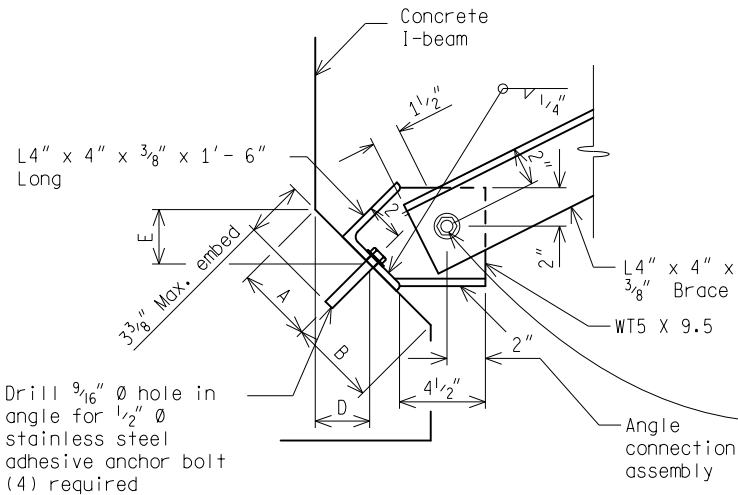

**SECTION E-E**

**NOTE:**  
Brace may be eliminated for strut lengths less than 2' - 6".

**Flange Dimensions**

Prestressed I-beam depth	A	B	D	E
28" (Type I)	4"	3 1/16"	2 13/16"	2 13/16"
36" (Type II)	4"	4 1/2"	2 13/16"	2 13/16"
45" (Type III)	4 1/2"	6 1/8"	3 3/16"	3 3/16"
54" (Type IV)	5 1/2"	7 1/4"	3 7/8"	3 7/8"

Anchor spacing = (Sign length minus 2") x COS θ  
Strut length = (Sign length minus 2") x SIN θ + 5"

**\* ADHESIVE ANCHOR MINIMUM EFFECTIVE ULTIMATE STRENGTHS**

INSTALLED IN CONC. BEAM FLANGE		INSTALLED IN DECK FASCIA		INSTALLED IN T-BEAM/BARRIER	
Tension (lbs)	Shear (lbs)	Tension (lbs)	Shear (lbs)	Tension (lbs)	Shear (lbs)
1275	825	5470	315	15500	9200
A1 Connection				A2 Connection	

\* Effective ultimate strength is equal to the ultimate strength modified by the appropriate edge distance and anchor spacing reduction factors recommended by the manufacturer.

**BRIDGE CONNECTION - TYPE A1**

\*\* See Pg 10 of 12 for bolt detail

NOT TO SCALE

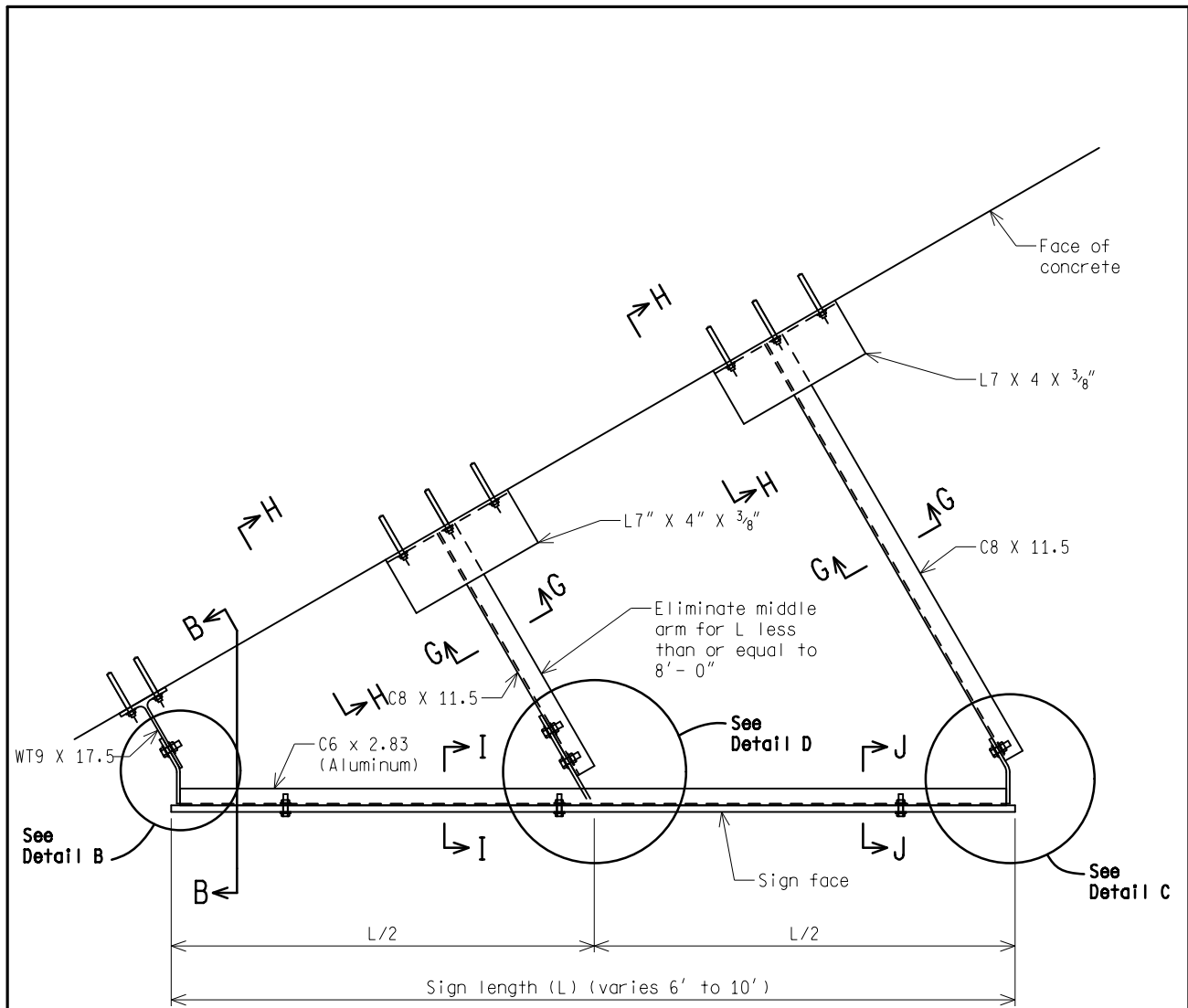

**PLAN**  
**5° - 40° CONNECTION**  
 (CONCRETE T-BEAMS & CONCRETE BARRIERS)

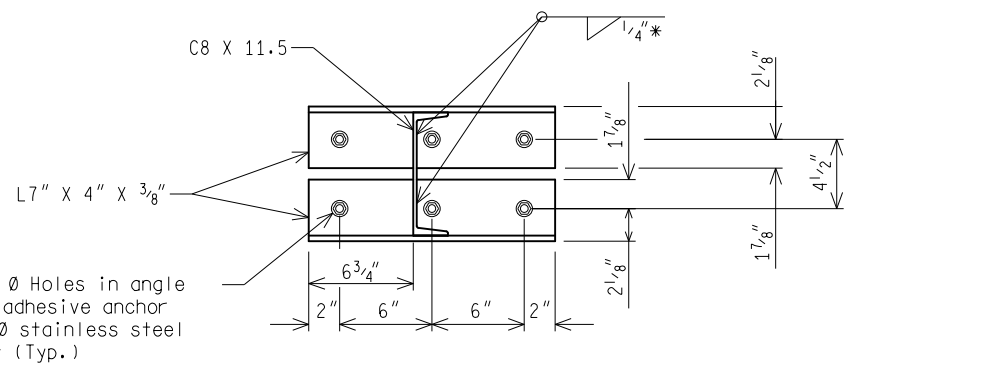

**SECTION G-G** \*Stop fillet weld short of corners

**BRIDGE CONNECTION - TYPE A2**

NOT TO SCALE

MICHIGAN DEPARTMENT OF TRANSPORTATION	(SPECIAL DETAIL) F.H.W.A. APPROVAL	08/08/23 PLAN DATE	SIGN-800-B	SHEET 5 OF 12
---------------------------------------	---------------------------------------	-----------------------	------------	------------------

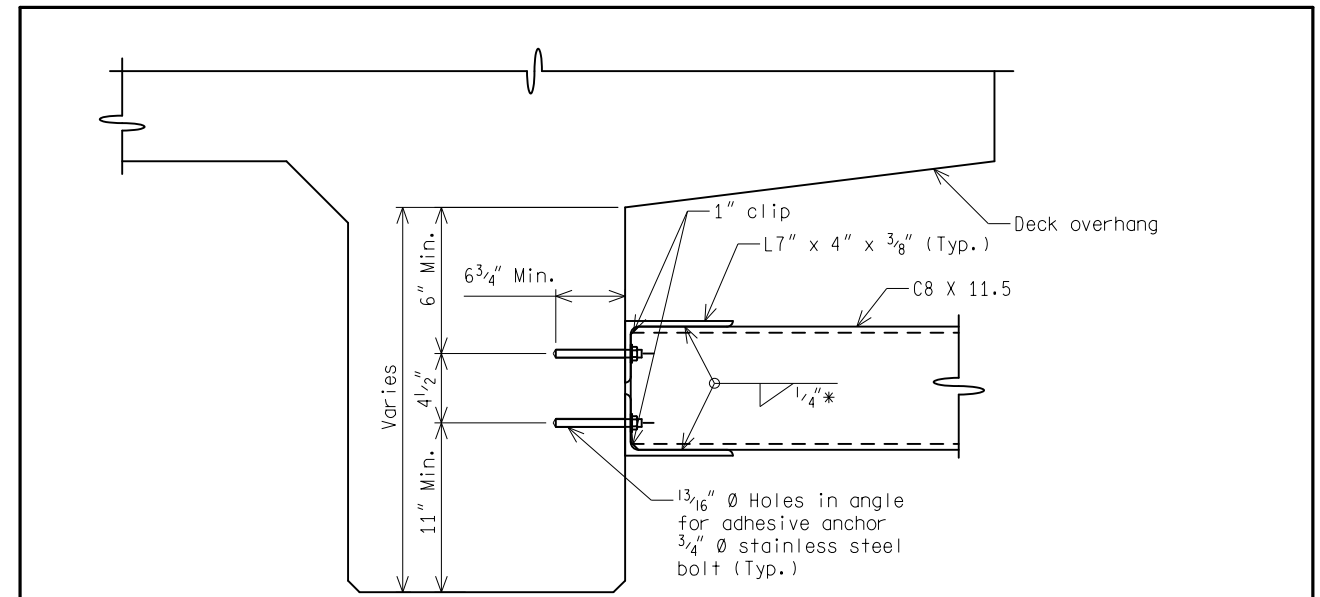

**SECTION H-H**  
 (AT CONCRETE T-BEAM BRIDGES)

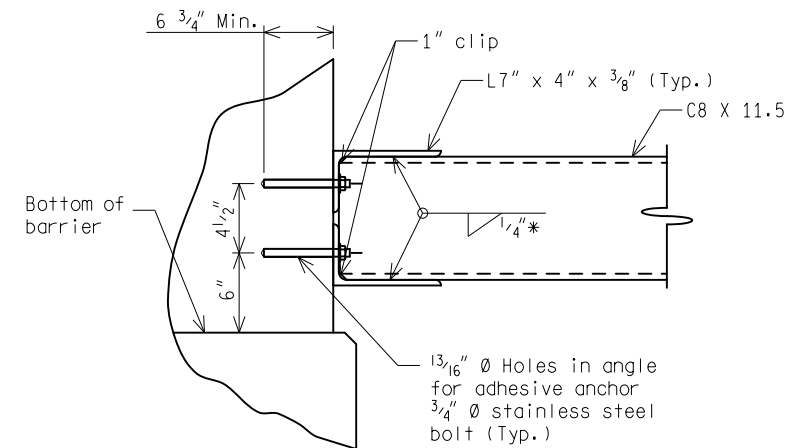

**SECTION H-H**  
 (AT CONCRETE BARRIER RAILING TYPE 4, TYPE 5  
 OR AESTHETIC PARAPET TUBE RAILING)

\*Stop fillet weld short of corners

NOTE:  
 See chart on sheet 4 for adhesive anchor strengths.

**BRIDGE CONNECTION - TYPE A2**

NOT TO SCALE

MICHIGAN DEPARTMENT OF TRANSPORTATION	(SPECIAL DETAIL) F.H.W.A. APPROVAL	08/08/23 PLAN DATE	SIGN-800-B	SHEET 6 OF 12
---------------------------------------	---------------------------------------	-----------------------	------------	------------------

1/16" Ø Hole for 5/8" Ø stainless bolt, (2) flat washers, & nylon insert lock nut. (2) required \*\*

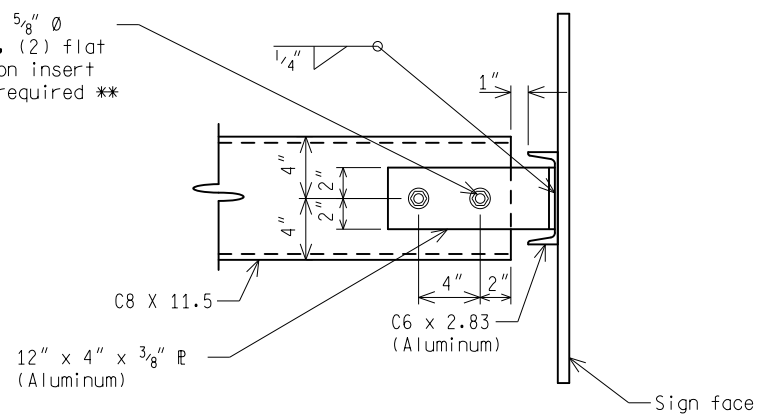

**SECTION I-I**

**NOTE:**

Place 1/8" elastomeric (or equivalent) pad to cover the entire surface area between steel and aluminum surfaces.

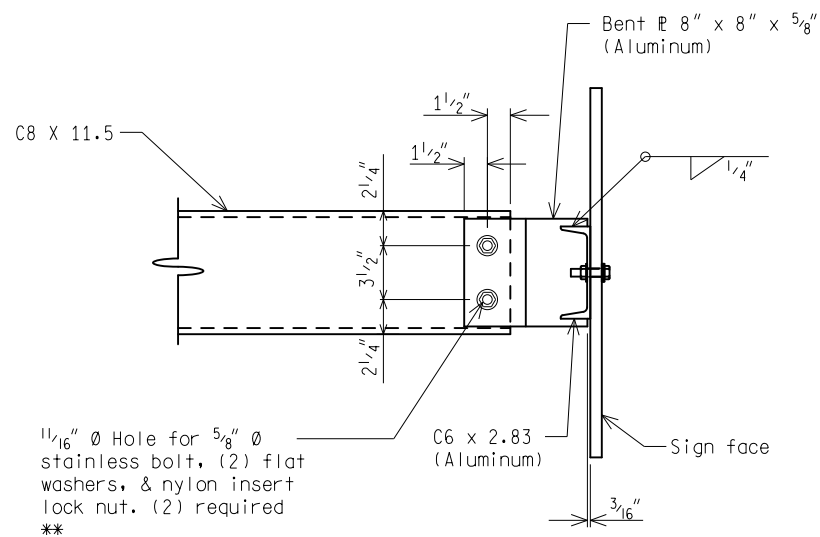

**SECTION J-J**

**BRIDGE CONNECTION - TYPE A2**

\*\* See Pg 10 of 12 for bolt detail

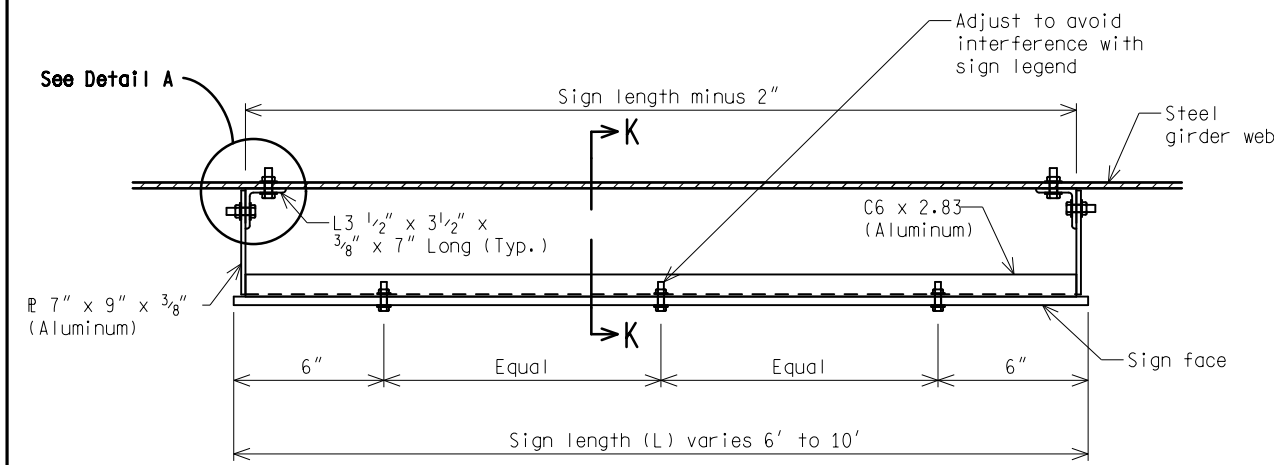

**PLAN 0° CONNECTION**

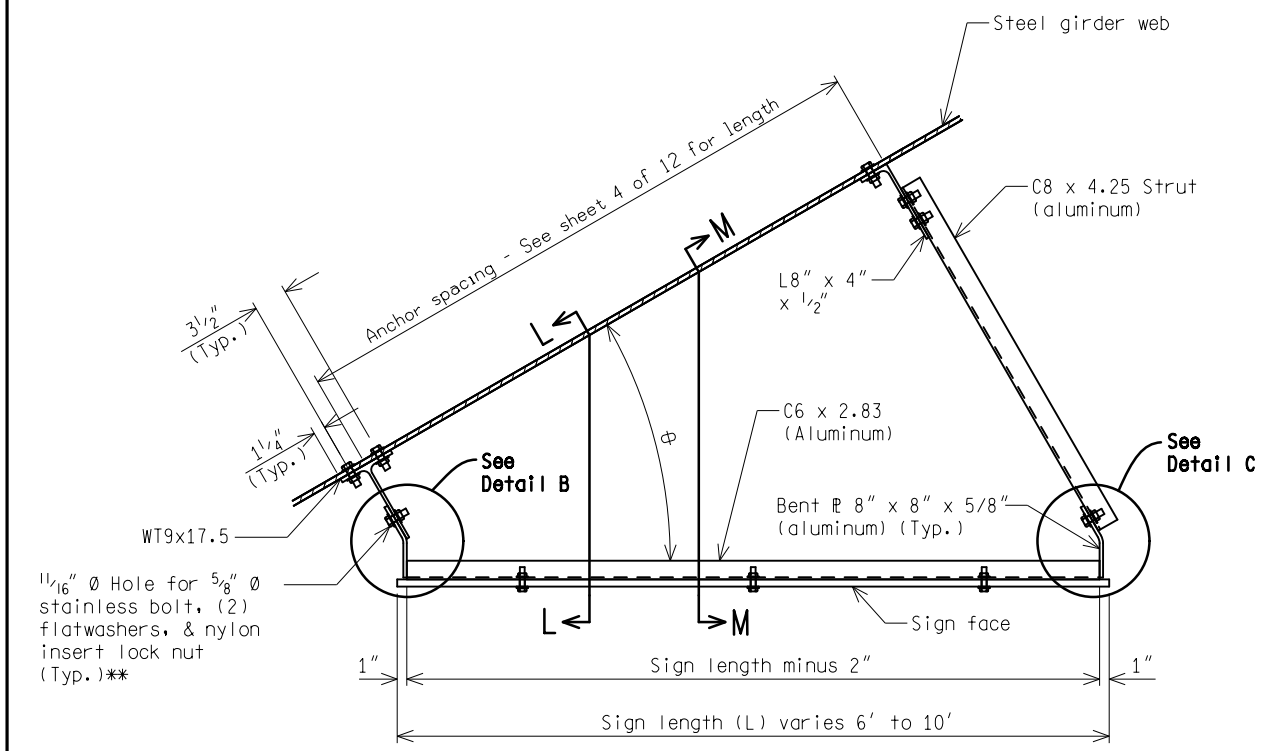

**PLAN 5° - 40° CONNECTION (STEEL BEAM)**

**BRIDGE CONNECTION - TYPE B**

\*\* See Pg 10 of 12 for bolt detail

NOT TO SCALE

MICHIGAN DEPARTMENT OF TRANSPORTATION	(SPECIAL DETAIL) F.H.W.A. APPROVAL	08/08/23 PLAN DATE	SIGN-800-B	SHEET 7 OF 12
---------------------------------------	---------------------------------------	-----------------------	------------	------------------

NOT TO SCALE

MICHIGAN DEPARTMENT OF TRANSPORTATION	(SPECIAL DETAIL) F.H.W.A. APPROVAL	08/08/23 PLAN DATE	SIGN-800-B	SHEET 8 OF 12
---------------------------------------	---------------------------------------	-----------------------	------------	------------------

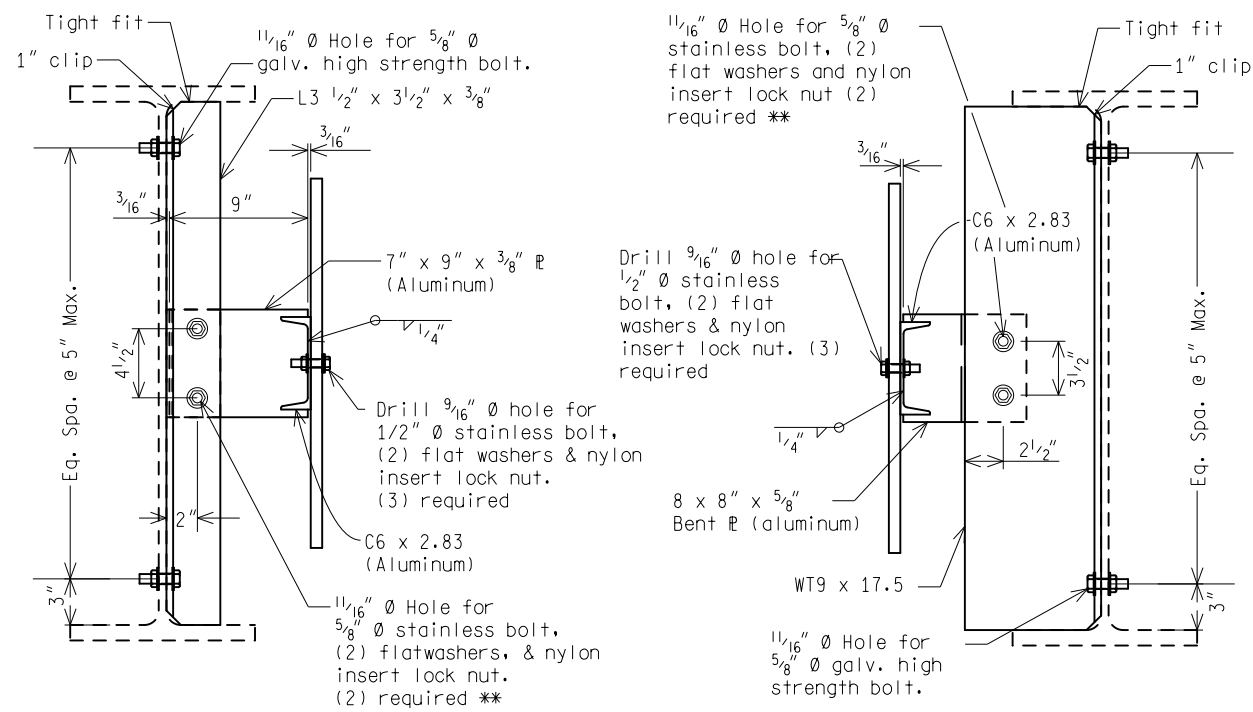

**SECTION K-K**

**SECTION L-L**

**NOTE:**  
Place 1/8" elastomeric (or equivalent) pad to cover the entire surface area between steel and aluminum surfaces.

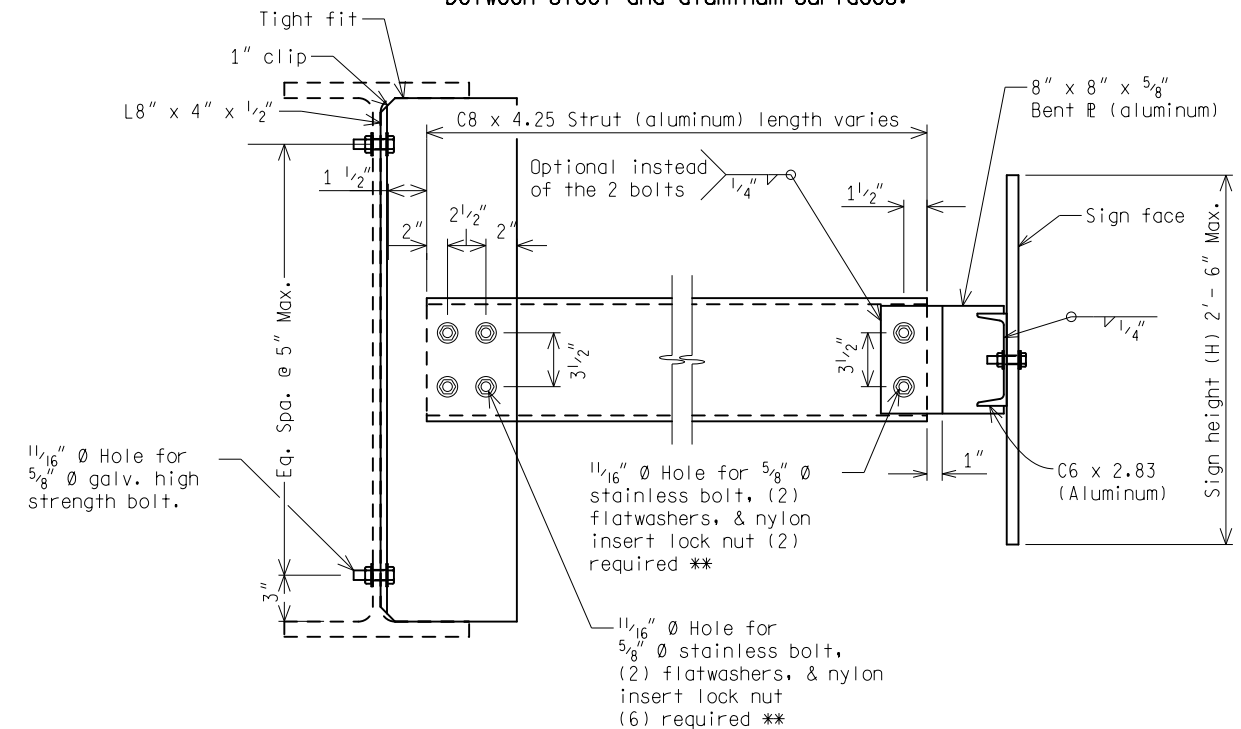

**SECTION M-M**

**BRIDGE CONNECTION - TYPE B**

\*\* See Pg 10 of 12 for bolt detail

NOT TO SCALE

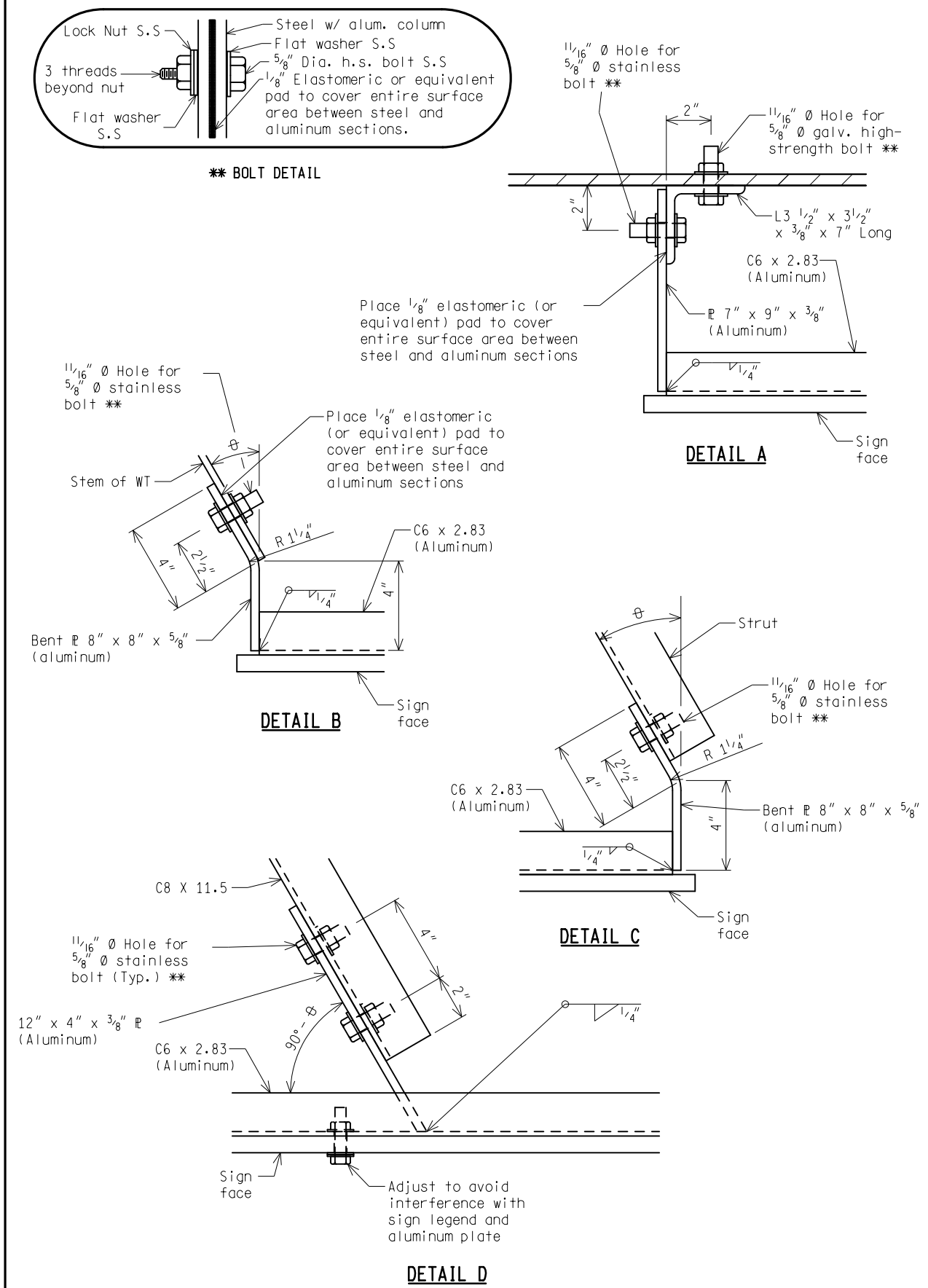

**\*\* BOLT DETAIL**

**DETAIL A**

**DETAIL B**

**DETAIL C**

**DETAIL D**

NOT TO SCALE

NOTES:

1. Field verify bridge dimensions prior to fabrication.
2. Welding shall be in accordance with the Standard Specifications for Construction.
3. All structural steel members shall be hot-dip galvanized in accordance with the Standard Specifications for Construction.
4. All aluminum members shall be ASTM B 308 aluminum alloy 6061-T6 and shall conform to ASTM B 221. Aluminum plates must be ASTM B 308 aluminum alloy 6061-T6 and must be according to ASTM B 209. All plates must be free of sharp edges and irregularities.
5. Structural steel members shall conform to AASHTO M 270 grade 36 or grade 50S.
6. All high-strength bolts, nuts and washers shall be in accordance with subsection 906.07 and installed according to subsection 707.03.E.6 of the MDOT Standard Specifications for Construction except for stainless steel bolts, nuts and washers.
7. Stainless steel bolts and washers shall conform to ASTM A 320, class 1, grade B8. Nuts shall be self-locking nylon insert type and must conform to ASTM A 320, grade 8F. Stainless steel nuts and washers shall always accompany stainless steel bolts. Stainless steel bolts, nuts and washers shall be used at connections with aluminum members. All other connections shall utilize galvanized high strength bolts, nuts and washers unless otherwise specified.
8.  $\theta$  = Angle between sign and bridge.
9. All concrete anchors shall be chosen from the qualified product list in the MDOT Materials Source Guide. All concrete anchors shall be installed according to the manufacturers recommendations and subject to the requirements of section 712.03.J of the MDOT Standard Specifications for Construction except that all field testing must demonstrate the anchor can develop 70 percent of the minimum effective ultimate strength shown in the plans with less than  $\frac{1}{16}$  inch slip. Field testing up to 90 percent of the bolts yield strength is waived. Extreme caution shall be exercised when drilling holes for concrete anchors. Existing bridge plans shall be reviewed to determine the prestressing strand locations and to evaluate the risk of damaging prestressing strands associated with installing concrete anchors.
10. The bottom edge of the sign shall be horizontal when erected.
11. If replacing an existing sign support, unused holes in steel bridge beams shall be filled with a galvanized high strength bolt installed according to subsection 707.03.E.6 of the MDOT Standard Specifications for Construction. Existing holes in concrete shall not be reused and shall be filled with a non-shrink grout in accordance with section 1005.02.B of the MDOT Standard Specifications for Construction.
12. Sign support connection shall be installed on one bridge span of a bridge structure and shifted to avoid conflict with joints or stiffeners.
13. For connections on ASTM A 588 weathering steel bridges, the connection interface shall be blast cleaned and primed with organic zinc-rich paint in accordance with section 715 of the MDOT Standard Specifications for Construction. If the existing bridge beam is unpainted ASTM A 588 weathering steel, the paint color shall be "brown weathering steel", federal code number 10062 and the paint shall overlap the perimeter of the connection by 2 inches, otherwise blend the paint to match existing paint color. the perimeter of the connections to the bridge beam web shall be sealed with an approved silicone sealant in accordance with subsection 713.03.F of the MDOT Standard Specifications for Construction. The bolted connections to the bridge beam web shall be according to subsection 707.03.E.6 of the MDOT Standard Specifications for Construction and shall utilize high strength bolts conforming to ASTM A 325 type 3.
14. Bridges built before 1978 contain lead based paint unless repainted after 1978.
15. Inspection of proposed locations shall be performed to determine viability of connection to existing bridge.

NOT TO SCALE

MICHIGAN DEPARTMENT OF TRANSPORTATION	(SPECIAL DETAIL) F.H.W.A. APPROVAL	08/08/23 PLAN DATE	SIGN-800-B	SHEET 11 OF 12
---------------------------------------	---------------------------------------	-----------------------	------------	-------------------

NOTES (Continued):

16. These sign support connections shall be used with Type II or Type III signs.
17. See subsection 810.03.P of the MDOT Standard Specifications for Construction for bolt replacement in retained bridge mounted sign connections.
18. Removal of existing bridge sign connections shall be according to subsection 810.03.U of the MDOT Standard Specifications for Construction.
19. See section 810 of the MDOT Standard Specifications for Construction for bridge sign connections to existing bridges.
20. Aluminum member designations are in accordance with the Aluminum Association Aluminum Design Manual, 2020 Edition. Aluminum channels are american standard series channels (C depth X weight).
21. All members are steel unless otherwise noted.
22. The design of these bridge sign connections are according to the AASHTO LRFD Specifications for Structural Supports for Highway Signs, Luminaires and Traffic Signals, 1st Edition, with interim revisions through 2022.
23. Type A1 denotes connections to concrete I-beam, steel I-beam bridges, bridge or barrier railing Type 4 or Type 5. Type A2 denotes connections to concrete T-beam bridges and connections to bridge barrier railing Type 4, Type 5 and aesthetic parapet tube railing. Type B denotes connections to steel.
24. For new bridges, surface rustication (texturing) at sign connections to railing shall be eliminated behind signs. For existing bridges, surface rustication (texturing) at sign connections to concrete shall be removed to a smooth surface. Care shall be taken to not remove excessive concrete below the depth of the texturing.

NOT TO SCALE

MICHIGAN DEPARTMENT OF TRANSPORTATION	(SPECIAL DETAIL) F.H.W.A. APPROVAL	08/08/23 PLAN DATE	SIGN-800-B	SHEET 12 OF 12
---------------------------------------	---------------------------------------	-----------------------	------------	-------------------