

**MICHIGAN'S EXPERIENCE WITH
NEOPRENE COMPRESSION SEAL**

Submitted for Possible Presentation
1971 Symposium on Joint Sealants
American Concrete Institute Committee 504-Joint Sealants

L. T. Oehler
F. J. Bashore

Research Laboratory Section
Testing and Research Division
Research Project 62 G-116
Research Report No. R-750

Michigan State Highway Commission
Charles H. Hewitt, Chairman; Wallace D. Nunn, Vice-Chairman;
Louis A. Fisher; Claude J. Tobin; Henrik E. Stafseth, Director
Lansing, September 1970

MICHIGAN'S EXPERIENCE WITH NEOPRENE COMPRESSION SEAL

Sealing joints in portland cement concrete pavement has been a continuing pavement design problem which has necessitated a vast amount of research. A variety of new materials and methods have been tried, most of which have had serious limitations; the remaining few have led to some improvement under certain conditions, but the panacea for this sealing problem has yet to be discovered. Our experience has shown, however, that for longer reinforced concrete slab lengths, preformed neoprene compression seals have shown marked improvement over all other types tested. This report discusses Michigan's prior experience with liquid seals, reasons for adopting preformed compression seals, the evolution of specifications for these seals, and our annual performance evaluation program.

Michigan first used neoprene seal for joints in concrete pavements in October 1949, when 30 contraction joints were sealed with this material on M 66 between M 43 and US 16 (Const. Proj. F 34-15, C4). This solid preformed seal had small ears on each side to be cast into the concrete on both sides of the joint. The preformed seal was supported in position by a 1/8-in. thick masonite plate fabricated to fit standard dowel bar assemblies. The paving concrete was then cast around this material to form the joint. The neoprene seal was intended to be 1/4 in. below the pavement surface but in many cases it was as much as 1 in. below. This first experience with neoprene seal was unsuccessful from two standpoints. First, the procedure used to install the seal was impractical and undesirable, and

second, performance evaluation indicated excessive spalling along the joint groove.

Until the second installation of preformed neoprene seal in 1962, the Department continued to use hot-pour rubber-asphalt for sealing paving joints. However, two extensive research attempts were made to try and improve joint seal performance. The first of these was a cooperative study with the Joint Seal Manufacturer's Association (JSMA) to improve the physical properties of joint sealing materials. All six members of the then newly formed association participated in the study. In 1956 a 10-mile experimental section of 24-ft concrete pavement was sealed with six different makes of each of two types of hot-pour rubber-asphalt sealer (regular type, meeting Fed. Spec. SS-S-164, and a slightly softer grade); five brands of cold-applied materials; and several products developed especially for this project by the various manufacturers. These special products included both hot-pour and two-component cold-applied materials of the jet-fuel resistant type. In total, 24 different joint sealing materials were placed for performance evaluation in 1/2-in. wide by 2-in. deep joint grooves. Joint spacing was 99 ft, which was conventional in Michigan at that time. Several inspections were made by JSMA and Research Laboratory representatives, the last one was made 2-1/2 years after seal installation. Although there were some variations in performance of the 24 different seals, it was concluded that none of the joints were well sealed (1).

The second major effort to improve joint seal performance was the construction of an experimental transverse joint project where joint groove shape and joint spacing were varied. The results of Professor Tons' research (2) concerning theoretical strains induced in joint seal materials were applied in this project by selecting joint seal groove configurations as follows: 1/2 by 1/2 in. , 3/4 by 3/4 in. , 1 by 1 in. , and 1/2 by 2 in. (the conventional shape groove). The first three joint seal grooves were sawed; the latter was formed by using styrofoam. In addition, joint spacing on the project was varied from the then standard 99 ft - 0 in. to 71 ft - 2 in. and 57 ft - 3 in. to determine if shorter joint spacings, combined with optimum joint groove shapes, could result in the satisfactory performance of hot-pour rubber-asphalt joint sealers. Subsequent performance evaluation showed that only minute amounts of cohesion failure occurred. However, seal failure due to loss of adhesion between seal and joint groove wall progressed in depth from year to year, resulting in full depth loss of 1/2 by 1/2 in. seals by approximately two years and for all seals regardless of shape by three years. No systematic improvement in joint seal performance was noted in the various joint groove configurations and shortening the slab length to 57 ft - 3 in. , thus reducing the sealer stress, did not materially improve performance.

In addition to these two major studies, many minor studies were made in attempts to improve sealer performance, but in each instance the results were the same—liquid sealers of the hot-pour or cold-applied type were not giving satisfactory performance in slab lengths compatible with reinforced concrete pavements.

The first of the more recent installations of neoprene seal was made in contraction joints on I96 near Lansing in September and October of 1962. The decision was made to substitute 1-in. wide neoprene compression seal for hot-pour rubber-asphalt seal for approximately a mile on eastbound and westbound roadways. It was realized that a 1-in. seal was marginal for 99-ft contraction joints; 1-1/4-in. seal was preferred but unavailable. The seal was placed in 1/2-in. wide by 2-in. deep formed joint grooves prepared for the liquid sealer. Even though this installation was marginal from a design standpoint, subsequent inspections have shown very little infiltration of dirt.

In August 1963, a group of Department engineers traveled to Buffalo to observe the performance of neoprene seals in New York. Although the joint spacing was shorter (60 ft - 10 in.) the delegation was impressed by the performance of the neoprene seals, the longest of which had been in service for three years. As a result of these observations and the continuing inability of hot-pour rubber-asphalt seal to perform satisfactorily for more than about two years, it was decided, starting December 4, 1963, to specify the use of preformed neoprene joint seal or two-component elastomeric polymer type, cold-applied joint seal for transverse joints and to permit neoprene, hot-pour or cold-pour for longitudinal joints. With 99-ft joint spacings, a 1-1/4-in. wide preformed neoprene contraction joint seal was placed in a 1/2-in. wide by 2-in. deep formed joint groove. Preformed neoprene 1-5/8-in. wide expansion joint seals were placed in 1-in. wide by 2-1/4-in. deep formed grooves.

From the beginning it was realized that for preformed seals to function properly, all joint groove spalls of significant size would require patching and

it was therefore specified that spalling which widened the joint groove by more than 1/4 in. must be patched with an epoxy mortar. Moreover, from the beginning it was specified that a vertical joint groove be formed at the vertical pavement edge so that the neoprene seal could be placed not only along the top surface of the pavement, but also down both edges of the slab to seal this vertical face from infiltration. The cross-sectional shape of the preformed seal was not specified but required Department approval. Department approval was based on whether the cross-section could be properly placed in a 1/2-in. wide groove, that its compressed vertical dimension would not protrude from the 1/2- by 2-in. groove, and that the seal retain a symmetrical shape when compressed. It was also specified that the joints must be sealed prior to any traffic, including construction traffic, on the pavement slab.

Specification Development

Initial specifications for the neoprene material were similar to those suggested by DuPont. Compression set requirements (70 hr at 212 F) were ██████ in accordance with ASTM D 395, Method B, paragraph 5(6), where test specimens consist of a sufficient number of plies of material to bring the thickness to approximately 1/2 in. From the beginning it was difficult to get repeatability with this test procedure.

Michigan decided to use preformed neoprene seals when they were still in a developmental stage; therefore, specification changes came at a fast and furious rate. By March 1964, after specifying these seals for about four months, the following changes were made:

- 1) The spacing of joints was changed from 99 ft to 71 ft - 2 in. This

change was not due to the use of neoprene but to the fact that an experimental project had indicated that joint spacing could be reduced somewhat without impairing the riding quality of the pavement. This change did, however, improve sealer performance by slightly decreasing the joint opening at cold temperatures.

2) Sawing of contraction joint grooves was permitted as an alternative to forming with a temporary joint filler.

By mid-1964 the old compression set requirement had also been dropped and a recovery test substituted in which the neoprene cross-section was compressed to 50 percent of its original width under the following conditions: 1) 70 hr at 212 F, 2) 70 hr at 14 F, and 3) 22 hr at -20 F. Corresponding minimum recovery specified was 90, 85, and 85 percent, respectively. We feel that the early institution of a recovery test on the preformed neoprene cross-section was a major factor in insuring the satisfactory performance which we have experienced. Seal specimens were compressed in the "as received" condition for the recovery test at 212 F, although talcing of the test specimens for the lower temperatures was permitted. We have since found that the only instances of web adhesion in the field occurred with a particular seal which had occasionally shown a tendency toward web adhesion in the 212 F recovery test.

By March 1965, the Department had received the approval of the Bureau of Public Roads to specify preformed neoprene compression seals exclusively in all transverse joints for the 1965 construction season. This approval was contingent upon a Departmental evaluation of joint seal performance of all 1964 and prior installations by the end of 1965. Early experience indicated, and subsequent annual winter condition surveys of sealer performance verified, that

neoprene seals, while still in the development stage as far as specification requirements were concerned, were easily out-performing the two-component elastomeric cold-applied sealers.

Also, by March 1965, two standard cross-sections were specified for contraction and expansion joint sealers with the provision that cross-sections other than the standard cross-section would be permitted by approval of the Department if their sealing characteristics were equal to those of the standard types.

In May 1965, in order to include half of the projects with sawed contraction joint grooves, two specifications were used, one permitted the plane-of-weakness to be sawed or formed with 1/4- by 2-in. temporary filler. In either case, however, the joint groove was subsequently sawed 1/2-in. wide by 1-3/4-in. deep. The other specification permitted forming the joint groove by the use of a temporary filler of expanded polystyrene, a smooth plastic insert, or other appropriate materials. The two specifications were used on individual projects from May to August 1965, at which time it was decided to permit the use of sawed contraction joint grooves only, since the practice of using temporary fillers such as styrofoam to form the groove led to excessive spalling of the joint groove edges which required subsequent patching with epoxy mortar. This practice of specifying sawing for both the plane-of-weakness and for the joint groove has continued to the present time; although we currently specify that the subsequent cuts for the joint grooves must be symmetrically placed 1/4 in. each side of the initial cut in order to remove as much spalling and raveling from the initial cut as possible.

Although preformed neoprene has been permitted along with hot-pour and cold-pour liquid seals for longitudinal joints since 1963, to date no neoprene seal has been used in longitudinal joints. The contractors have elected to use the cold-pour liquid sealants, and since experience has shown that the longitudinal joint is not as critical a maintenance problem as are transverse joints, it has not been deemed necessary to specify neoprene compression seals exclusively for these joints.

During the development of joint construction procedures for neoprene seals, certain problems have arisen regarding expansion joints. Initially, the joint groove for the 1-5/8-in. neoprene joint seal was formed 1-in. wide and either 2-1/4- or 2-1/2-in. deep. Thus, the width of the joint groove was the same width as the bituminous expansion joint filler below it. Procedures for forming the joint groove above the filler were never very satisfactory. In any forming process there is a tendency to taper the joint groove, leading to a greater width at the top of the groove than at the bottom. Previous experience with expansion joints has shown that the 1-in. filler is compressed by expansion forces in the adjacent slabs during periods of higher temperature and moisture content until the 1-in. expansion joint filler will generally be compressed to approximately 1/2 in. after several years, and as an extreme may be compressed to approximately 1/4 in. The 1-in. joint grooves are subsequently reduced along with the expansion filler to approximately 1/2 in. (Fig. 1). It was found that when the preformed neoprene seal being used was compressed to 3/4 in., it became essentially a solid mass of neoprene. Consequently, by the summer of 1965 it was found that expansion seals were

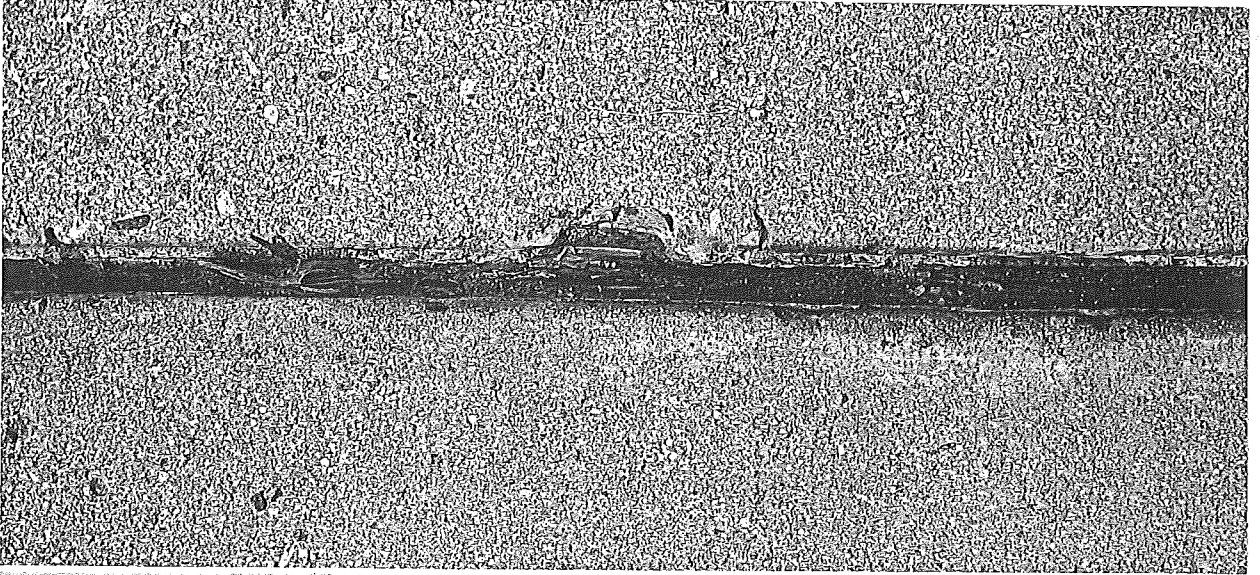

Figure 1. Expansion seal with end partially expelled from joint, which is closed to 1/2 in. at this point.

Figure 2. Expansion seal which has had top worn away during summer. Bottom portion is doing effective job of sealing joint during winter (2-20-69).

being partially extruded from the joint groove and abraded or worn away by traffic on some projects (Fig. 2). Several techniques for alleviating this condition appeared possible. First, it was decided to saw the joint groove above the expansion joint filler rather than forming it with a temporary filler, thus insuring that the joint groove faces were vertical. Second, it was possible to reduce the thickness of outside and inside web members so that the cross-section could be compressed to somewhat less than 1/2 in. without using up all voids in the sealer cross-section. A lighter cross-section was used on a project experimentally with the same 1-in. wide joint groove. Subsequent observations have shown that this did not resolve the problem because eventually the expansion seals on this project also partially extruded and are being worn away by traffic. The principal reason for the lack of success was the inability of the manufacturer to produce the thinner walled cross-section consistently. Consequently, much of the material could not be compressed to less than 1/2 in. as had been anticipated. Another solution, the one which was adopted for all later projects, was to increase the width of the expansion joint groove to 1-1/4 in. Thus, with subsequent closing of the joint groove, the width remains a minimum of about 3/4 in. and the expansion sealer can resist this amount of compression without extruding. One other provision was subsequently added that required that the width of joint grooves be cut to 1-1/4 in. plus any increase in width of the initial relief cut, since it was noted that at times some problems did arise if the width of joint grooves were cut arbitrarily to the 1-1/4 in. width without taking into account the 1/8- to 3/16-in. opening which may take place by

the time the final sawing is done for the joint groove width. This 1-1/4-in. joint groove width may result in only marginal compression of the seal during cold weather the first winter when the joint reaches maximum opening, but after the first winter, compression of the joint filler takes place and in subsequent winters the joint groove does not open as far.

In a limited number of joints, where extrusion of the expansion seal took place, maintenance procedures have been to remove the expansion seal and place the 1-1/4-in. wide contraction joint seal in these compressed joint grooves. This procedure appears to remedy the situation quite satisfactorily, although in almost all cases the expansion seal is only partially extruded and, while somewhat unsightly, sufficient seal remains in the joint groove to prevent the infiltration of foreign material into the joint (Fig. 2).

No significant changes in specifications occurred from August 1965 to 1969. However, in 1969 a requirement was added to mark the top of the neoprene seal at 12-in. intervals, within a tolerance of $\pm 1/16$ in. at room temperature. This requirement was added to make it readily possible for the inspector to check compliance with the installation requirement limiting the stretching to a maximum of 5 percent.

A major change was also made in handling the approval of the neoprene cross-section. Previous specifications included drawings of particular cross-section designs along with provisions for approving alternates, based largely upon engineering judgement. It was thought that it would be preferable to omit any reference to particular designs so that development of new designs might be stimulated. Certain overall dimensional controls and certain force requirements of the seal under specified compressed conditions

were substituted. Along with these requirements it was necessary for the manufacturer to demonstrate in the field the proper installation of several transverse joints with each size and shape to be used. In this demonstration the installed seal must not exhibit any twisting, rolling, misalignment of opposite top edges, tendencies to trap incompressibles, or any other qualities deemed by the Department to be detrimental to installation.

The force requirements for an approved seal are as follows:

1-1/4-in. Contraction Seal:

Compressed to 1 in. - 4.0 lb per lin in. minimum.

Compressed to 1/2 in. - 35 lb per lin in. maximum.

1-5/8-in. Expansion Seal

Compressed to 1-1/2 in. - 4.0 lb per lin in. minimum.

Compressed to 5/8 in. - 25 lb per lin in. maximum.

The minimum force requirements were derived somewhat arbitrarily. Laboratory evaluations of seals currently available indicated that a minimum of 4.0 lb per lin in. could be provided at the above maximum design joint groove openings without exceeding the above maximum compressive forces at the minimum design joint groove openings. While we don't as yet know how much compressive force decrease to expect over the life of the seal, we have limited data to show that up to 70 percent of the initial force is lost after two year's service. For this reason, we felt it prudent to specify as high an initial force as could be reasonably obtained.

The purpose of the maximum compressive force requirement for contraction joint seals is to insure ease of installation at summer temperatures and to prevent over straining of the material during subsequent periods of maximum joint groove closure. The maximum force requirement for the expansion seal is for one reason only; to insure the capability of the seal to be compressed

to at least 5/8 in. without extruding from the joint groove.

Fatigue studies of neoprene seals were started in 1967 in an attempt to determine if long time service performance might be interpreted from short time repetitive load fatigue testing. The tests were not intended to simulate in-service conditions such as traffic abrasion and weathering.

The first objective of this test program was to determine if meaningful and reproducible results could be obtained from cyclic compression loading. Other objectives were much more ambitious, including effects of material properties and cross-sectional shape factors on fatigue. The specially fabricated laboratory fatigue testing machine is shown in Figures 3 and 4. The neoprene cross-section was compressed to 60 percent of its original width and then released at a rate of 260 cycles per minute under room temperatures. Repeatability of the results for a given lot of material was very poor. Results varied from failure at 78,000 cycles to no failure at 2,150,000 cycles for nine samples tested from a given section of preformed neoprene with a mean fatigue life of 600,000 cycles. Fourteen specimens of material meeting the acceptable physical properties were tested in comparison with twelve specimens from unacceptable material (material which cracked under compression tests at 212 F, or which failed to meet the minimum elongation requirements). The average of the acceptable specimens was 649,000 as compared to 302,000 for the unacceptable material. However, the in-sample variation exceeded the differences in averages and it was concluded that the fatigue testing of neoprene seals does not provide meaningful or reproducible results. Most fatigue failures occurred by cracking of web members in the cross-section of the seal, although some failures were by cracking of the outer walls. In

Figure 3. Overall view of Research Laboratory fatigue testing machine for preformed neoprene compression seal.

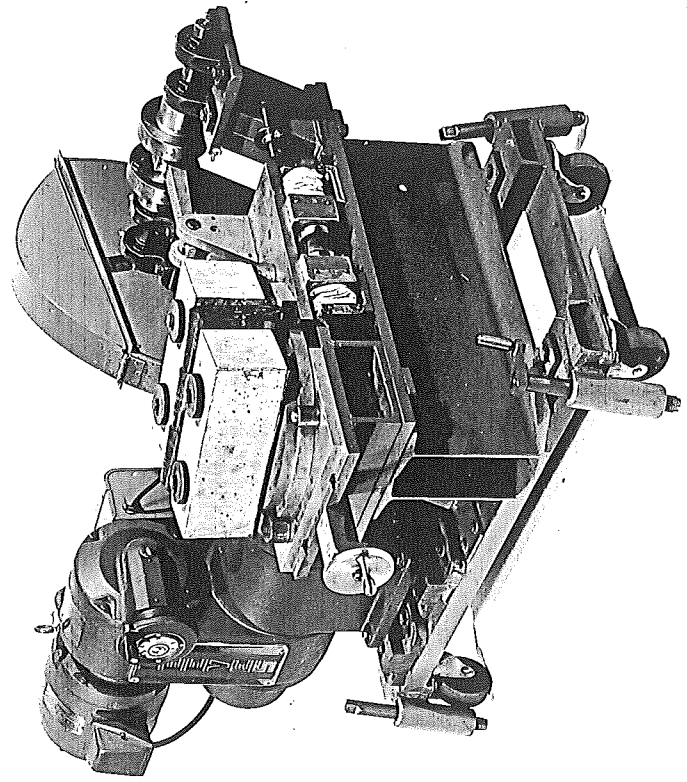
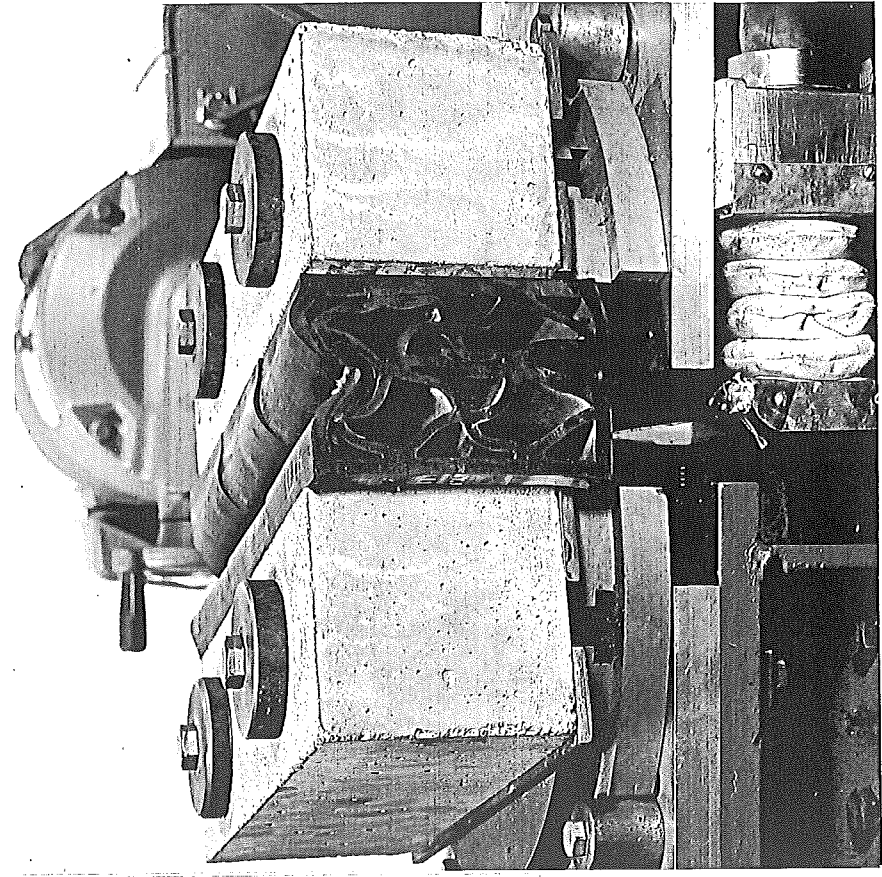

Figure 4. Detailed view of 4-in. bridge seal subjected to fatigue testing.



most every case the member in the cross-section which is most severely bent under compression of the seal is the member which cracks first under cyclic loading.

Use of Neoprene Seals in Bridge Decks

The use of preformed neoprene seals in joints in concrete bridge decks has closely paralleled their use in pavements. Our first installations were made in three bridge structures in 1963. These seals were of very light construction compared to those in current use, and were not large enough to accommodate the range of movement involved. Since 1963, neoprene seals have been used in over 150 structures. Approximately half of these installations were of 1-1/4-in. seals in construction joints, since the expansion joints in these structures were designed to move more than could be accommodated by our largest standard seal (4 in. wide). The other seals used were 2 in., 2-1/2 in., 3 in., and 4 in. although the 2-1/2-in. seal is not currently used.

We have made a limited number of two-component elastomeric installations in different types of joints; from construction joints, which move very little, to expansion joints which move over 100 percent, using the joint groove width at 60 F as a reference. We have found that failure occurs within a year in almost all cases. Even in construction joints where the movement is nil, failure in adhesion develops wherever the sealant is poured high enough for contact with traffic. Our experience with hot-pour rubber-asphalt is similar, except that sealing construction joints is quite satisfactory other than at curb faces, where the material slumps at summer temperatures.

During the past two winter seasons we have made condition surveys of joints in over 130 bridge decks constructed during the past 10 years. The results of these surveys show that the neoprene seals are doing a much better job than any of the other materials, although there are certain problems that need attention.

We specify notching the seal at curbs so that it can be bent to conform to the contour of the curb area (Fig. 5). Inadequate depth of the notch may permit the seal to move out of the joint when the groove is at its widest. Inadequate buffing of the notch to a smooth surface sometimes causes the seal to break because of stress concentrations. In some cases, even though the notching is done properly, distortion of the seal at the bend permits water leakage. To eliminate these types of failure, designs which require a gentle curve upward into the curb area, without notching, are being prepared (Fig. 6).

We have used the sliding plate expansion dam for the applications where movements up to 3-1/2 in. are required. Since none of the current materials will satisfactorily seal these joints for more than one season, the Department is currently experimenting with two other systems. One is the modular system, where several preformed neoprene seals are used, sandwiched between small beams; the other is the Transflex steel reinforced neoprene type, where a metal plate is encased in neoprene which is, in turn, bonded to other metal components which are firmly attached mechanically to adjoining deck slabs (Figs. 7 and 8). Movement is accommodated by deformation of the neoprene.

Material specifications for bridge seals have changed along with those for pavement seals. We have not adopted pressure requirements to take the place of standard cross-sections. We do permit cross-sections other than

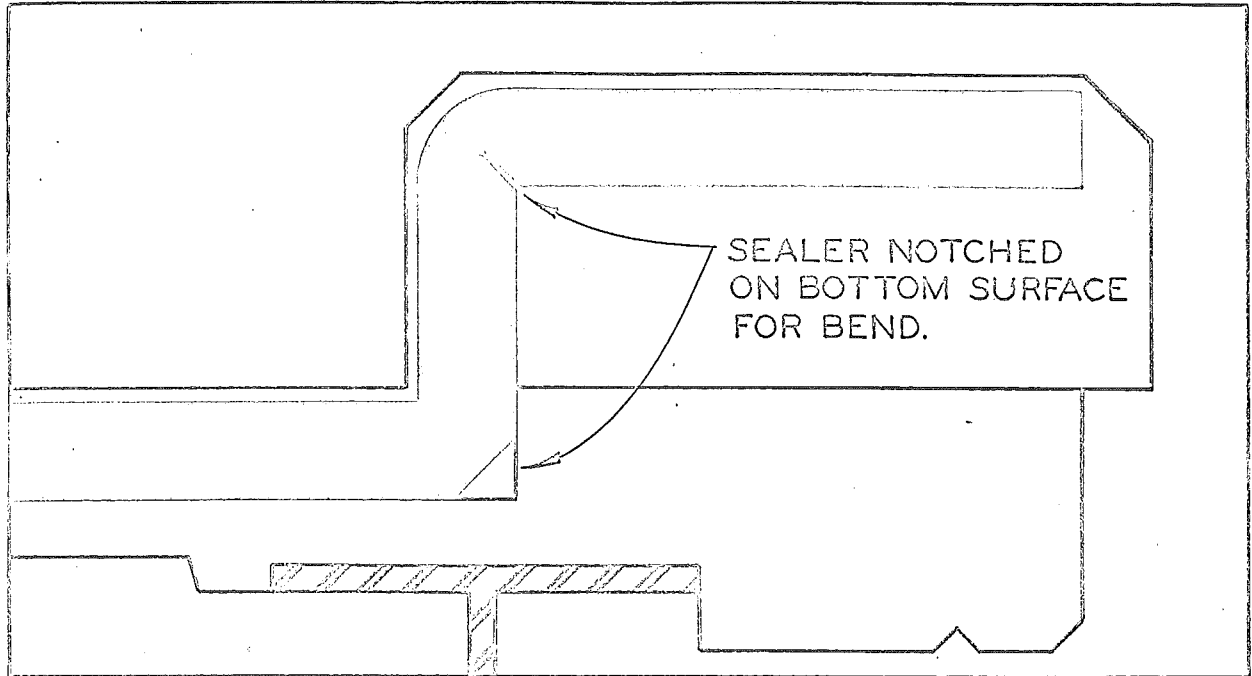

Figure 5. Elevation showing current practice of notching neoprene bridge seal for turns in curb area.

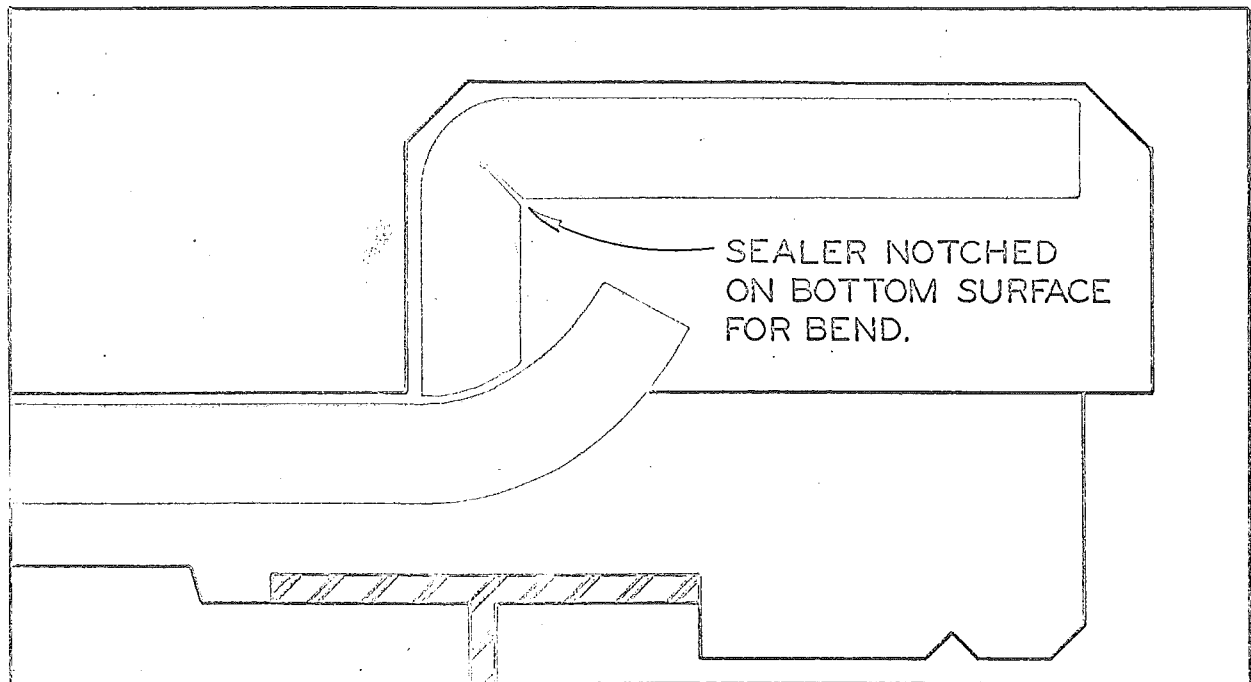

Figure 6. Elevation showing neoprene bridge seal bent upward into the curb area without notching.

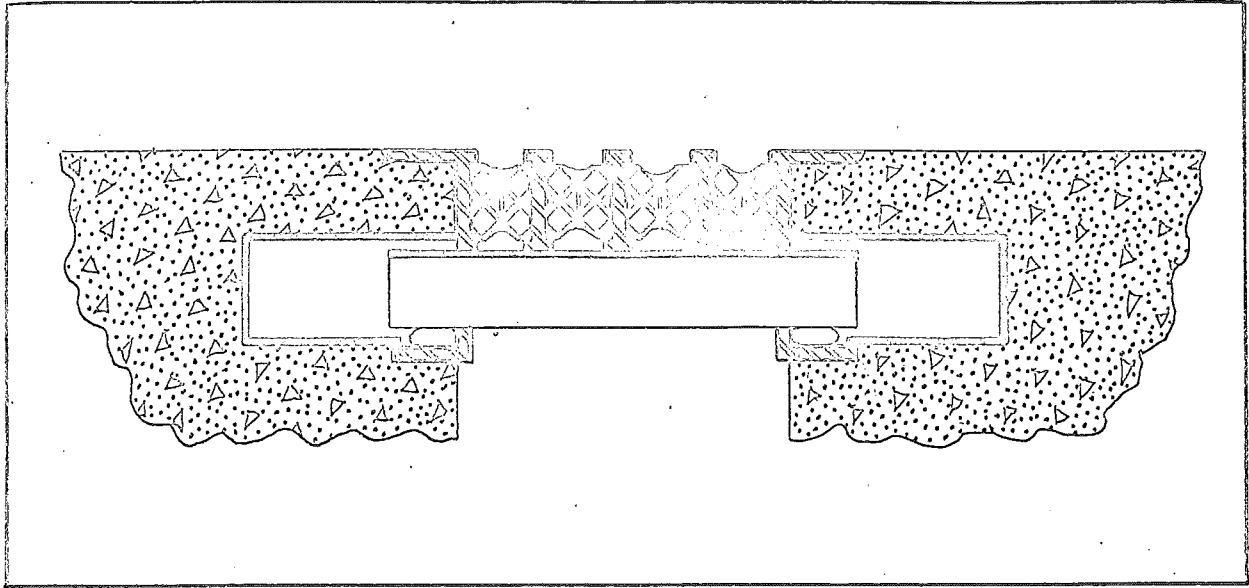

Figure 7. Modular system utilizing several preformed neoprene seals.

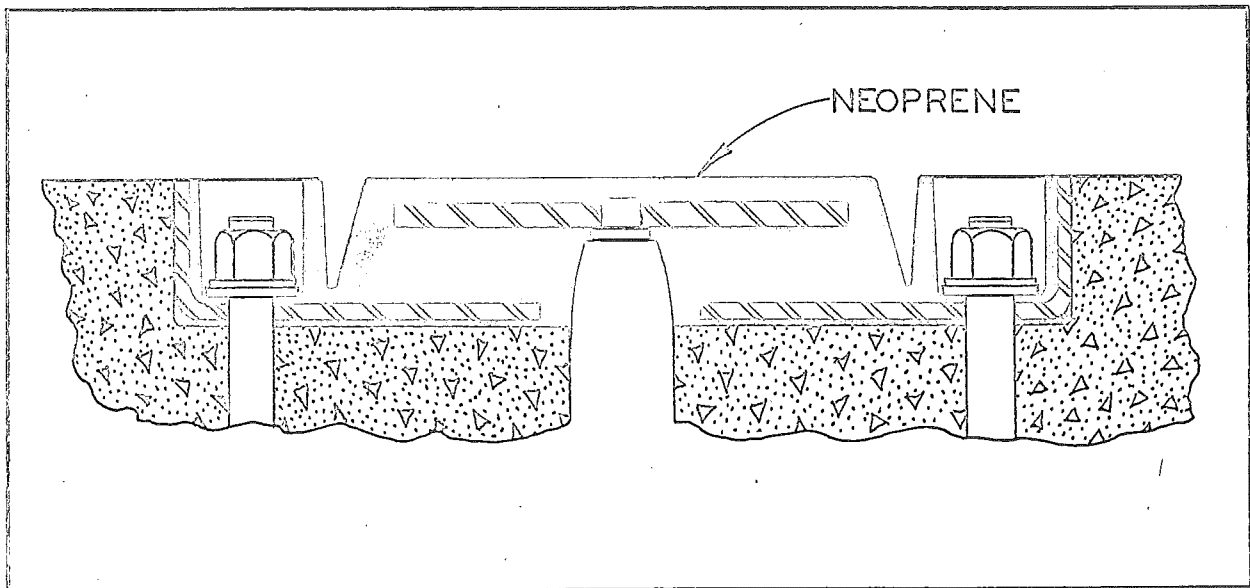

Figure 8. Transflex system utilizing steel reinforced neoprene.

the standard types after laboratory evaluation indicates that the seal will function properly. While pressure measurements are not required for acceptance of material, we run compression tests on all submitted samples for research purposes. We don't have enough experience as yet to specify a minimum acceptable pressure for bridge seals.

Joint Seal Condition Surveys

Condition surveys of joints in over 100 miles of concrete pavement in representative construction projects are conducted each winter season. These surveys were initiated in 1965 to evaluate and compare the performance of preformed neoprene, hot-pour rubber-asphalt, and two-component elastomeric joint sealants. Joint groove condition, sealant condition, and effectiveness of seal are observed. Selected joints on each project are photographed annually. Figure 9 shows neoprene sealed joints soon after installation and again after five years of service. This information is used to compare seal designs, materials, joint groove forming methods, and installation procedures. Because of the early failure of materials other than preformed neoprene, only neoprene seals are currently being surveyed. The only exceptions are two projects where hot-pour rubber-asphalt was used in expansion joints and preformed neoprene in contraction joints. These expansion seals were installed in 1965 and 1966 and are performing well to date.

Each year new construction projects are added and enough old ones deleted to keep the total within a practical number, i. e. , one which can be surveyed in about six weeks by a crew of six to eight men, including a photographer (Fig. 10).

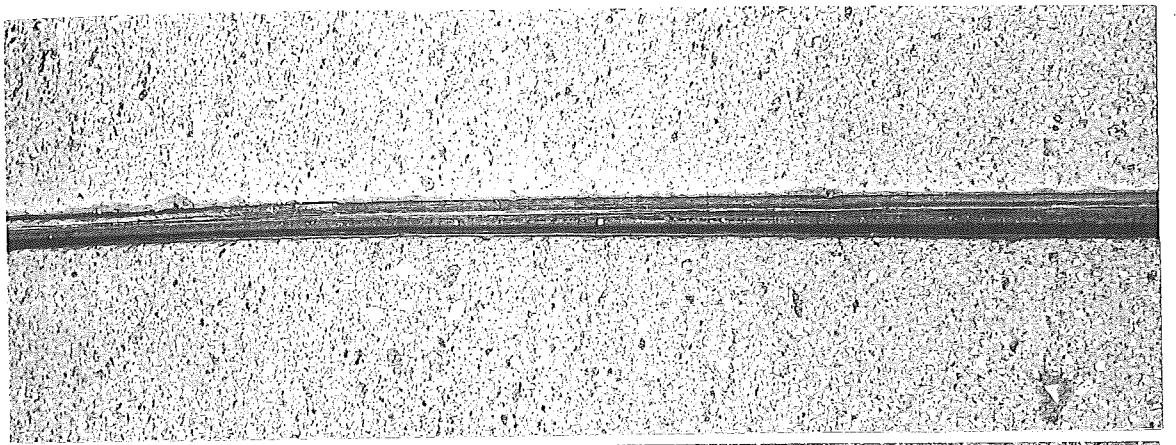

Photo 2-24-70

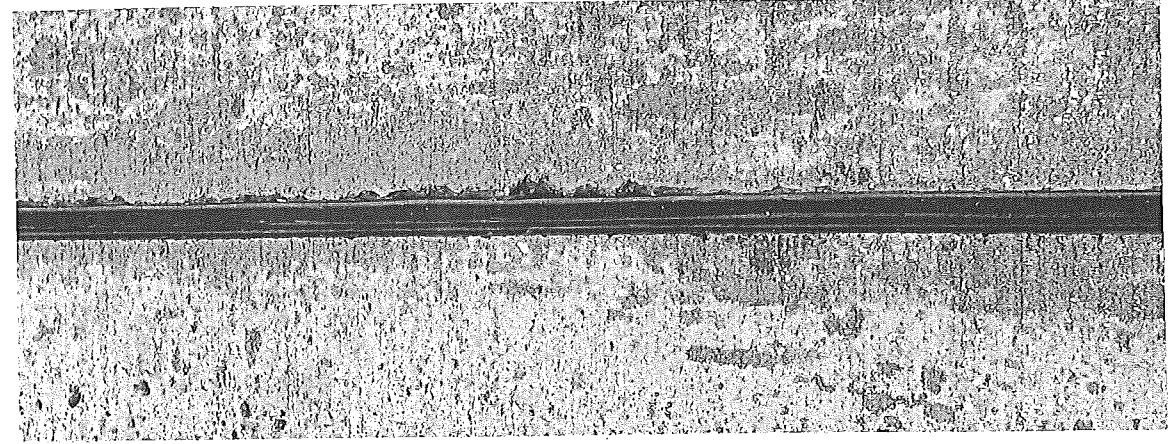

Photo 3-16-65

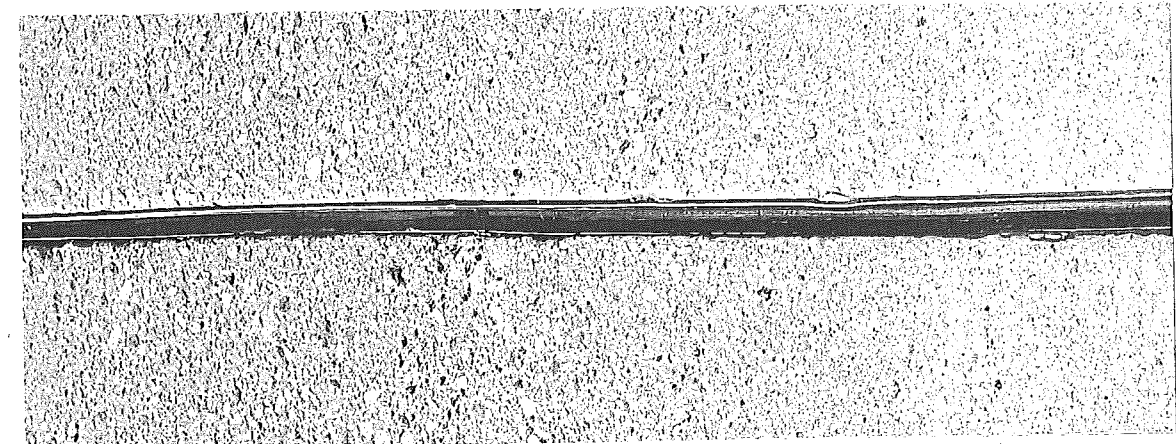

Photo 2-24-70

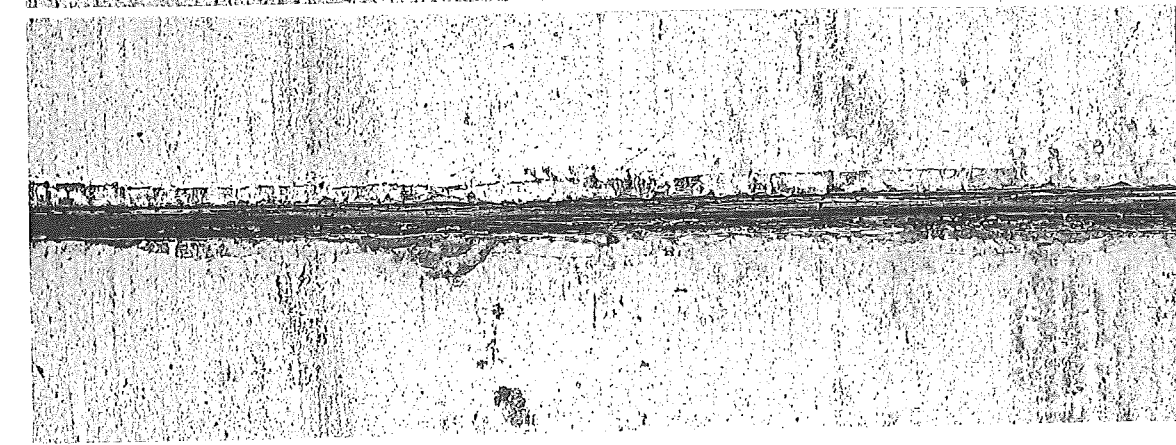

Photo 3-16-65

Sta. 444+30 EB

Sta. 906+04 WB

Figure 9. Typical contraction joints sealed with neoprene after five years service on I 196 in Grand Rapids soon after sealing and

Figure 10. Joint groove condition survey crew examining contraction joint.

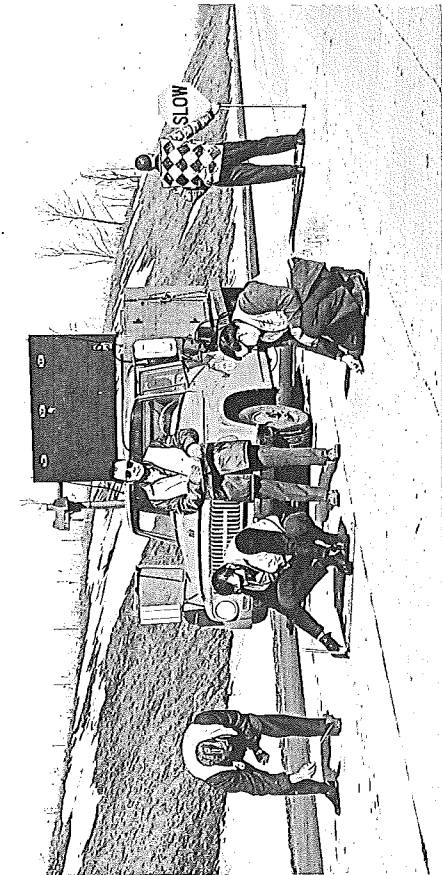

Figure 11. Concrete under neoprene sealed joint at left is sound as contrasted with deteriorated concrete under hot-pour seal at right. Both were installed in 1962 on I 96, Lansing.



Sta. 599+08 EB

(Photo 8-10-70)

Sta. 590+18 EB

(Photo 9-1-70)

In addition to these yearly joint surveys, overall condition surveys are taken on newly completed construction, and at subsequent five-year intervals, in order to evaluate the general performance of Michigan's pavements. All visible indications of deterioration are noted, such as transverse or longitudinal cracking, corner breaks, joint spalling, pavement patching, resurfacing, etc. Much of this deterioration occurs at pavement joints. After five or ten years of service, joint spalling is prevalent on a number of construction projects. Also, after ten and fifteen years of service, joint blowups occur. Based on our experience with 99-ft slabs with joints sealed with hot-pour rubber-asphalt sealer, an average of 0.7 percent of the joints have blowups at the end of ten years, and 4.2 percent at the end of fifteen years (3). Studies have shown that the projects with early joint spalling are the same projects which subsequently have serious joint blowup problems. Although it is rather early to predict with certainty, it appears that we will have reduced joint spalling on pavements sealed with neoprene seals. It also follows logically that with the lack of infiltration of foreign materials into neoprene sealed pavement joints, blowups should be greatly reduced in future years as these pavements reach a service life of fifteen years where blowups have been experienced in previously constructed pavements. Comparison of a few hot-pour rubber-asphalt and preformed neoprene sealed joints on the same construction project sealed in 1962 shows serious deterioration of the concrete under the hot-pour material as contrasted with sound concrete under the neoprene seal (Fig. 11).

Summary

The most obvious improvements have been a result of forming joint grooves by sawing and the exclusive use of neoprene seals in all new con-

struction. The only serious problem has been the extrusion of expansion seals which was previously discussed. We believe that our 1-1/4-in. sawed joint groove in combination with the currently specified seals will solve this problem.

We specify that contraction seals be placed $1/4$, $\pm 1/8$ -in. below the pavement surface. We have observed that when seals are placed within these tolerances, they tend to be self-cleaning. When placed deeper, debris does accumulate above the seal but no damage has been observed from this accumulation.

We plan to continue annual condition surveys of neoprene sealed pavements which now total an equivalent of over 600 miles of 24-ft pavement. Condition surveys of joints in bridge structures will likewise be devoted primarily to neoprene seals. In conjunction with annual surveys of joints, portions of seals with known initial physical properties are removed periodically to measure change in tensile and compressive force properties. The information obtained from these surveys and evaluations should enable us to further upgrade our specifications for materials and construction procedures.

REFERENCES

1. C. C. Rhodes and L. T. Oehler, "Performance of Hot-Poured and Cold-Applied Joint Sealers." Michigan State Highway Department Research Laboratory Report No. R-493.

2. Tons, Egon, "A Theoretical Approach to Design of a Road Joint Seal," Highway Research Board Bulletin 229, 1959, pp. 20-53.

3. L. T. Oehler and L. F. Holbrook, "Performance of Michigan's Postwar Concrete Pavements," Michigan Research Report No. R-711, August 1970.