

**TYPE I**

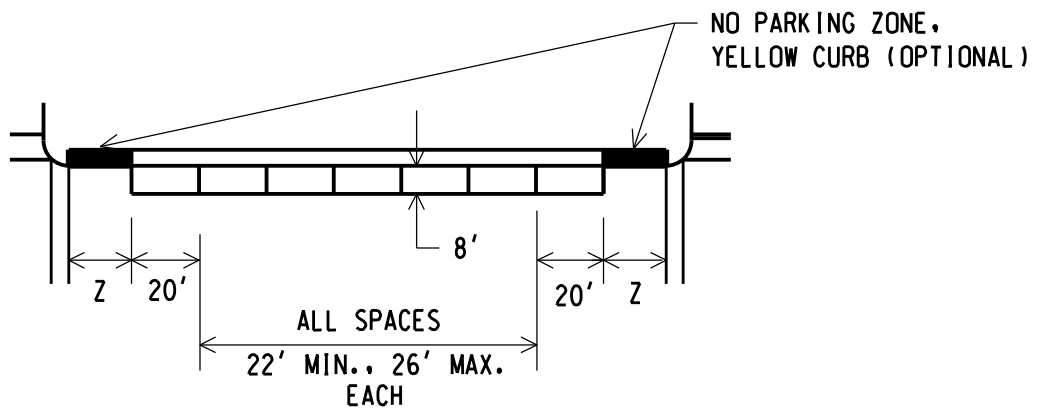

**TYPE II**

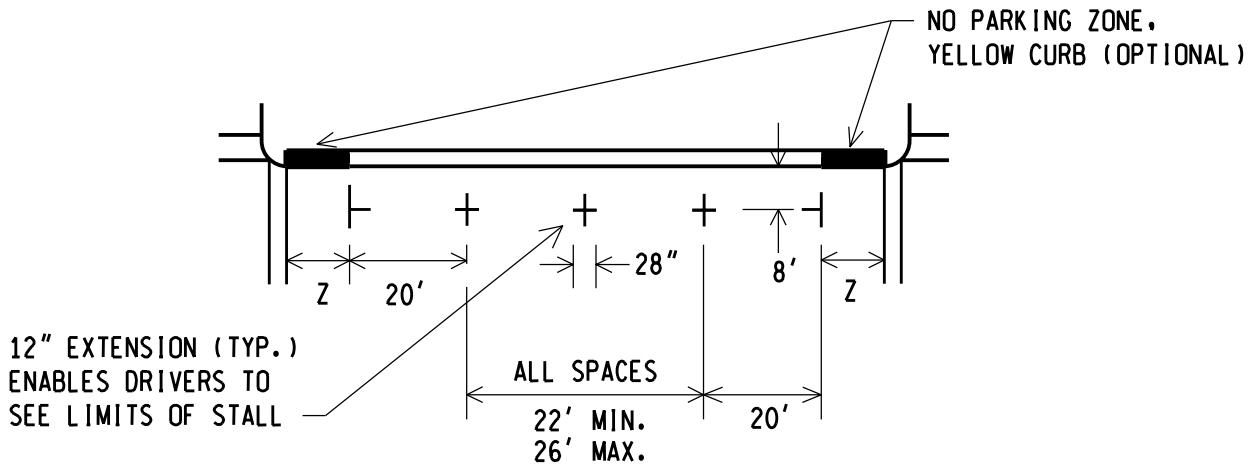

**TYPE III**



PREPARED  
BY  
TSMD DIVISION

DRAWN BY: JME

CHECKED BY: JGM

DEPARTMENT DIRECTOR  
Paul C. Ajegba

APPROVED BY: Gregg Brunner, P.E. Gregg Brunner  
Nov 2 2020 12:09 PM

DIRECTOR, BUREAU OF FIELD SERVICES

APPROVED BY: Bradley C. Wiefelich Bradley C. Wiefelich  
Nov 5 2020 5:51 AM

DIRECTOR, BUREAU OF DEVELOPMENT

MICHIGAN DEPARTMENT OF TRANSPORTATION  
BUREAU OF DEVELOPMENT STANDARD PLAN FOR

**ON-STREET  
PARKING ZONE MARKINGS**

09/21/20  
F.H.W.A. APPROVAL

03/25/20  
PLAN DATE

PAVE-955-C

SHEET  
1 OF 2

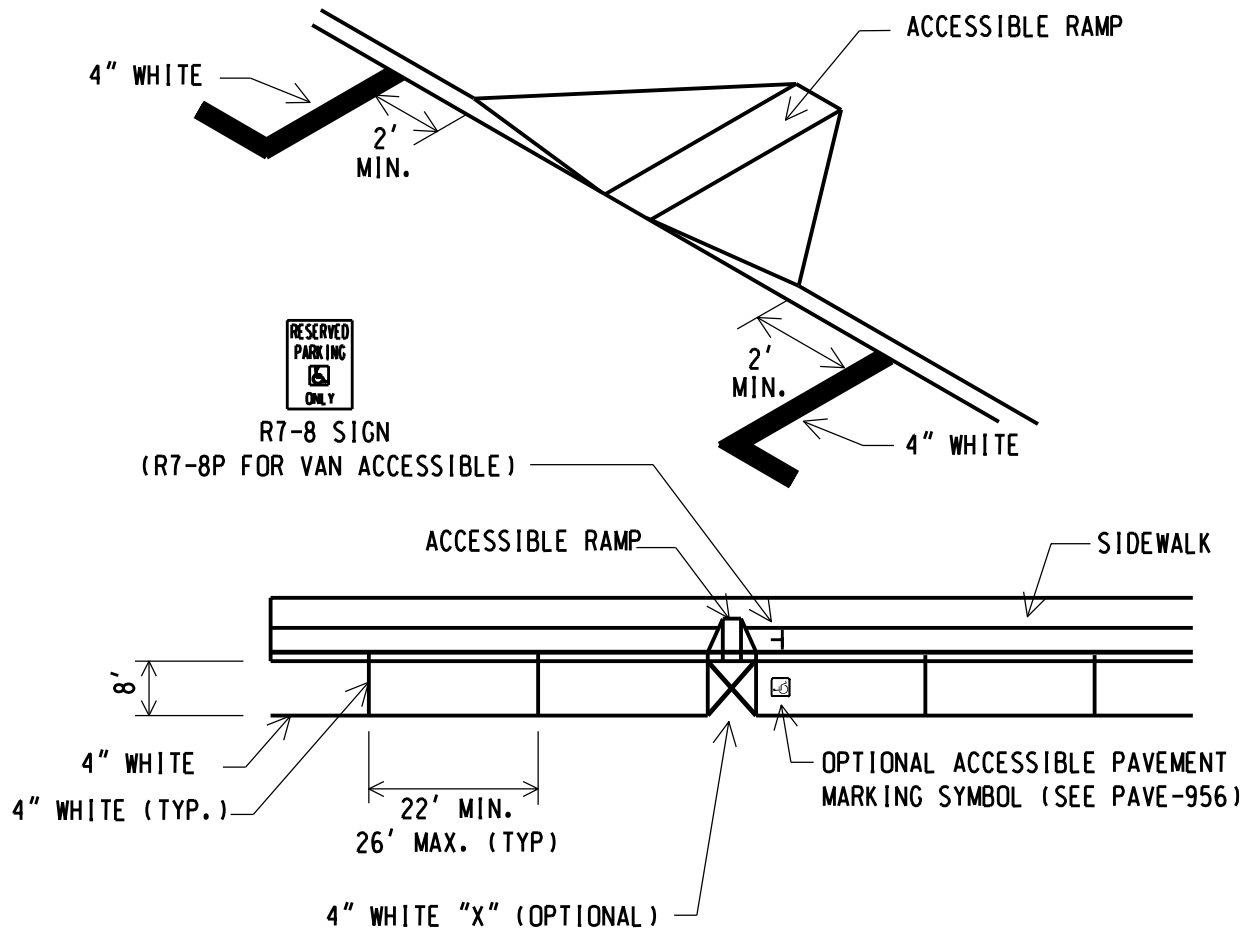

## ACCESSIBLE MARKINGS

INTERSECTION TYPE	"Z" (FT)
NO TRAFFIC CONTROL NO CROSSWALK	15
NO TRAFFIC CONTROL WITH CROSSWALK	20
TRAFFIC CONTROL PRESENT	30
SEE SECTION 257.674 OF THE MICHIGAN VEHICLE CODE FOR MORE INFORMATION.	

### NOTES:

1. All parking zone markings shall be retroreflective 4 inch white. 4 inch blue may supplement the white zone marking for an accessible stall.
2. For mid-block driveway, clearance from parking stall to the curb cut shall be 20 ft minimum.
3. The use of a yellow (or other color) painted curb to denote a no parking zone is optional, and shall only be used to supplement standard signs.
4. On-street parking for state trunk lines through municipalities shall be one of the three types illustrated.
5. Type II on-street parking zone markings shown this sheet, Type I or III may also be used.

NOT TO SCALE

MICHIGAN DEPARTMENT OF TRANSPORTATION  
BUREAU OF DEVELOPMENT STANDARD PLAN

09/21/20  
F.H.W.A. APPROVAL

03/25/20  
PLAN DATE

PAVE-955-C

SHEET  
2 OF 2