

Research on Evaluation and Standardization of Accelerated Bridge Construction Techniques

Final Report - Appendices (2015-2017)

Project Manager: Mr. Corey Rogers, P.E. and Mr. Mike Halloran, P.E.

Submitted to:



Submitted by:

Haluk Aktan, Ph.D., P.E.
Professor
(269) 276 – 3206
haluk.aktan@wmich.edu

Upul Attanayake, Ph.D., P.E.
Associate Professor
(269) 276 – 3217
upul.attanayake@wmich.edu



Western Michigan University
Department of Civil & Construction Engineering
College of Engineering and Applied Sciences
Kalamazoo, MI 49008
Fax: (269) 276 – 3211

APPENDIX A: ABBREVIATIONS

AAA	American Automobile Association
AASHTO	The American Association of State Highway and Transportation Officials
ABC	Accelerated Bridge Construction
ADT	Average Daily Traffic
ADTT	Average Daily Truck Traffic
ARE	The Federal Office for Spatial Development of Switzerland
ATRI	The American Transportation Research Institute
AU	Advanced User
BU	Basic User
CALTRANS	The California Department of Transportation
CC	Conventional Construction
CC	Climate Change
CFC	Chlorofluorocarbon
CH ₄	Methane
CN	Canadian National
CO	Carbon Monoxide
CO ₂	Carbon Dioxide
CPI	Consumer Price Index
CPM	Capital Preventive Maintenance
CSM	Capital Scheduled Maintenance
D-M	Decision-Making
DOT	The Department of Transportation
EPA	The US Environmental Protection Agency
FC	Facility Carried
FE	Finite Element
FHWA	The Federal Highway Administration
GHG	Greenhouse Gas
GUI	Graphical User Interface
GWP	Global Warming Potential
HP	Steel H-Piles
I-xx	Interstate Highway-xx
LOS	Level of Service
MDOT	The Michigan Department of Transportation
Mi-ABCD	Michigan Accelerated Bridge Construction Decision
MMT	Millions of Metric Tons
MOHSP	The Michigan Office of Highway Safety and Planning

MOT	Maintenance of Traffic
MSE Walls	Mechanically Stabilized Earth Retaining Walls
M-xx	Michigan Highway-xx
N ₂ O	Nitrous Oxide
NJDOT	The New Jersey Department of Transportation
NO ₂	Nitrogen Dioxide
OQI	The Office of Quality Improvement
PBES	Prefabricated Bridge Elements and Systems
PM	Particulate Matter
PM ₁₀	Particles Between 2.5 Microns and 10 Microns in Aerodynamic Diameter
PM _{2.5}	Particles Less Than 2.5 Microns in Aerodynamic Diameter
pmt	Passenger Miles Travelled
SCF	Speed Correction Factor
SHRP2	The Strategic Highway Research Program 2
SIBC	Slide-In Bridge Construction
SPMT	Self-Propelled Modular Transporter
TCB	Temporary Concrete Barrier
tm	Ton-Miles
TMP	Traffic Management Plan
USDOE	The U.S Department of Energy
USDOT	The U.S Department of Transportation
VBA	Visual Basic for Applications
VOC	Volatile Organic Compound
WIM	Weigh-In-Motion
WisDOT	The Wisconsin Department of Transportation
WMU	Western Michigan University
WP	Water Pollution
WZM	Work Zone Mobility

APPENDIX B: NOTATIONS

A_a	= accident rate due to work zone
A_{apv}	= accident rate per vehicle mile due to work zone
A_{at}	= accident rate per truck mile due to work zone
AC	= accident cost
ADT_{pv}	= average daily passenger vehicle traffic
ADTT	= average daily truck traffic
AE	= average expenditure per household
A_F	= actuating force
A_n	= accident rate
A_{npv}	= normal accident rate for passenger vehicles
A_{nt}	= normal accident rate for trucks
a_s	= acceleration measured in the direction of sliding
a_t	= acceleration measured in the direction transverse to sliding
AVO	= average vehicle occupancy
b	= width of the roller contact area
C	= actuator capacity
C	= center of geometry
C_a	= average cost per accident
C_{ap}	= average medical cost per accident per person
CC	= impact to climate change
CC_{pv}	= impact to climate change from passenger vehicles
CC_t	= impact to climate change from trucks
CMF	= crash modification factor
CP	= health care costs from pollutant
CP_{CO}	= health care cost due to carbon monoxide
CP_{NO_2}	= health care cost due to nitrogen dioxide
$CP_{PM_{10}}$	= health care cost due to particles between 2.5 microns and 10 microns in aerodynamic diameter
$CP_{PM_{2.5}}$	= health care cost due to particles less than 2.5 microns in aerodynamic diameter
CP_{VOC}	= health care cost due to volatile organic compounds
DDC	= driver delay cost
E	= modulus of elasticity
E_{pv}	= emission of a pollutant from passenger vehicles
E_R	= elasticity modulus of the roller material
E_t	= emission of a pollutant from trucks
E_t	= modulus of elasticity of sliding track material

e_1	= moment arm of actuation forces
e_2	= moment arm of transverse forces
F	= the frequency of patronizing a specific business
f_{si}	= friction forces or resisting forces developed at each track
f_{yT}	= yield strength of sliding track material
g	= acceleration of gravity
HC	= health care cost
HC_{pv}	= health care cost related to passenger vehicles
HC_t	= health care cost related to trucks
HWA	= number of houses without direct access
I	= mass moment of inertia
j	= actuator jerk
L	= length of the affected roadway due to bridge construction
L_{Dpv}	= length of detour for passenger vehicles
L_{Dt}	= length of detour for trucks
L_R	= contact length of a roller
L_{WZpv}	= length of the road segment closed to passenger vehicles during construction
L_{WZt}	= length of the road segment closed to trucks during construction
m	= superstructure mass
N	= construction duration in days affecting the work zone
n	= of rollers in contact with the track
N_F	= net force
O	= position of the accelerometers with respect to the direction of sliding and the center of geometry
P	= the percent of households without direct access avoiding the area influenced by the project
PAC	= passenger accident cost
PDC	= passenger delay cost
r	= distance between centroid and instrumentation location
R_F	= resisting forces develop at transverse restraints due to yaw (referred as transverse forces)
r_{pv}	= average hourly vehicle operating cost for passenger vehicles
R_R	= radius of a single roller
r_t	= average hourly vehicle operating cost for trucks
S_a	= work zone speed limit
SC_{CO_2}	= social cost of carbon dioxide
SCF	= speed correction factor

SCF_{Dpv}	= the detour speed correction factors for passenger vehicles
SCF_{Dt}	= the detour speed correction factors for trucks
SCF_{NSpv}	= the speed correction factor for normal speed limit within the road segment with no construction for passenger vehicles
SCF_{NSt}	= the speed correction factor for normal speed limit within the road segment with no construction for trucks
SCF_{WZ}	= the work zone speed correction factor
SCF_{WZpv}	= the work zone speed correction factor for passenger vehicles
SCF_{WZt}	= the work zone speed correction factor for trucks
S_F	= sliding force
S_L	= actuator stroke length
S_n	= normal speed limit of the roadway
T	= torque exerted on superstructure at centroid
T_{Dpv}	= time to travel via detour for passenger vehicles
T_{Dt}	= time to travel via detour for trucks
T_M	= mobility impact time
t_T	= transverse movement tolerance
T_{WZpv}	= time to travel along a distance equal to the road segment that is closed due to construction at the normal posted speed for passenger vehicles
T_{WZt}	= time to travel along a distance equal to the road segment that is closed due to construction at the normal posted speed for trucks
UC_p	= unit cost of a pollutant
UC_{wpv}	= unit cost of water pollution from per mile travel of passenger vehicles
UC_{wt}	= unit cost of water pollution from per ton-mile travel of trucks
V_{Dpv}	= speed limit when travelling through detour for passenger vehicles
V_{Dt}	= speed limit when travelling through detour for trucks
VOC	= vehicle operating cost
V_{pv}	= volume of passenger vehicle traffic on the roadway to be closed during construction
V_t	= volume of truck traffic on the roadway to be closed during construction
V_{WZpv}	= speed limit of the closed section of the road for passenger vehicles
V_{WZt}	= speed limit of the closed section of the road for trucks
W	= the weight of the superstructure and all the components and attachments above the sliding surface
WP	= total water pollution damage
w_p	= hourly rate for a passenger
WP_{pv}	= water pollution damage from passenger vehicles

WP_t	= water pollution damage from trucks
w_{pvd}	= hourly rate for passenger vehicle drivers
w_t	= hourly rate for truck drivers
α	= angular acceleration at instrumentation location
ΔC	= change in numbers of customers
ΔR	= business revenue change
ΔF_{si}	= net sliding force at each track
$\Delta\mu$	= coefficient of friction difference between each sliding track
μ	= friction coefficient
ν	= Poisson's ratio
ν_R	= Poisson's ratio of the roller material
ν_s	= sliding velocity
ν_T	= Poisson's ratio of sliding track material
ρ	= mass-density
σ_B	= bearing pressure
σ_{max}	= maximum normal stress acting on the sliding track
σ_R	= maximum roller pressure
τ_{max}	= maximum shear

APPENDIX C: COMMUNITY AND BUSINESS SURVEY TEMPLATES

General Public Survey

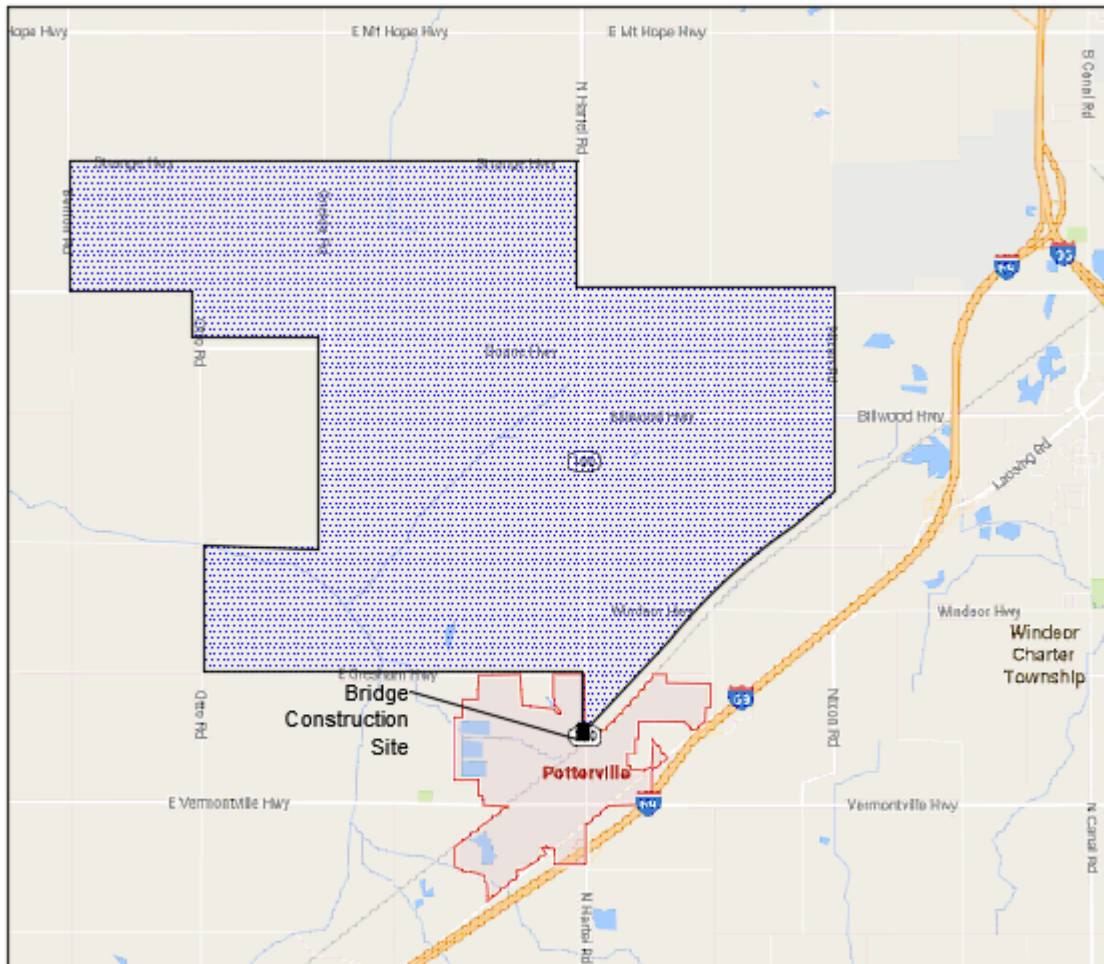
The purpose of this survey is to collect data in an effort to evaluate the economic impact of bridge construction projects on surrounding communities and businesses. Your responses are valuable to us. Your information, and the information you provide for us, will be kept confidential. Where needed, the data will be used as summaries.

General Information:

Date: _____

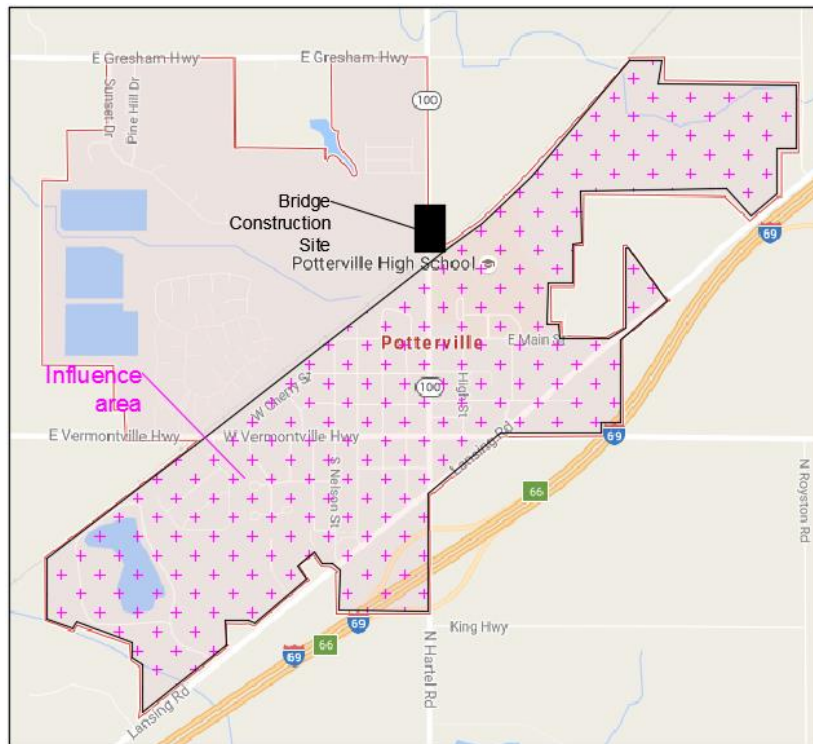
1. Is your residence located within the area shaded on the following map?

Yes _____ No _____



Bridge construction projects around communities impact the normal traffic flow. Usually, traffic is routed around the project with detour signs, requiring community members to use a different route. The extra traveling affects the amount of fuel you use; the additional time spent away from work or home; and your environment due to increased pollution. Accelerated Bridge Construction (ABC) projects keep the road open for as long as possible (even when work is being performed to construct the new bridge and foundation); therefore, reducing the impact of traffic interruption. However, the ABC project cost is (20%-40%) more than a conventional bridge project.

The following map shows a hatched area influenced by the construction and where a majority of the businesses are located at. Your understanding about this area is necessary to answer some of the questions listed below.



Impact on Daily Life:

Please circle your answer for the following questions.

2. Did you use the designated detours around the construction site? (Yes) (No)
3. If yes, did the detour provide adequate access to your destination? (Yes) (No)
4. If yes, was the detour route in good condition? (Yes) (No)
5. Did the detour increased cost or time of your commute? (Yes) (No)

Please use \surd mark to indicate your answers.

6. How often do you go to the following businesses/stores inside the influence area shown in the map?

Number of trips	Before Construction					During Construction				
	0	1-2	3-4	5-6	7 or more	0	1-2	3-4	5-6	7 or more
Restaurants (per week)	<input checked="" type="checkbox"/>	<input type="checkbox"/>	<input checked="" type="checkbox"/>	<input type="checkbox"/>	<input checked="" type="checkbox"/>	<input type="checkbox"/>	<input checked="" type="checkbox"/>	<input type="checkbox"/>	<input checked="" type="checkbox"/>	<input type="checkbox"/>
Party/Liquor Store (per week)	<input checked="" type="checkbox"/>	<input type="checkbox"/>	<input checked="" type="checkbox"/>	<input type="checkbox"/>	<input checked="" type="checkbox"/>	<input type="checkbox"/>	<input checked="" type="checkbox"/>	<input type="checkbox"/>	<input checked="" type="checkbox"/>	<input type="checkbox"/>
Grocery Store (per week)	<input checked="" type="checkbox"/>	<input type="checkbox"/>	<input checked="" type="checkbox"/>	<input type="checkbox"/>	<input checked="" type="checkbox"/>	<input type="checkbox"/>	<input checked="" type="checkbox"/>	<input type="checkbox"/>	<input checked="" type="checkbox"/>	<input type="checkbox"/>
Gas Stations (per month)	<input checked="" type="checkbox"/>	<input type="checkbox"/>	<input checked="" type="checkbox"/>	<input type="checkbox"/>	<input checked="" type="checkbox"/>	<input type="checkbox"/>	<input checked="" type="checkbox"/>	<input type="checkbox"/>	<input checked="" type="checkbox"/>	<input type="checkbox"/>
Clothing Stores (per month)	<input checked="" type="checkbox"/>	<input type="checkbox"/>	<input checked="" type="checkbox"/>	<input type="checkbox"/>	<input checked="" type="checkbox"/>	<input type="checkbox"/>	<input checked="" type="checkbox"/>	<input type="checkbox"/>	<input checked="" type="checkbox"/>	<input type="checkbox"/>
Hardware Stores (per month)	<input checked="" type="checkbox"/>	<input type="checkbox"/>	<input checked="" type="checkbox"/>	<input type="checkbox"/>	<input checked="" type="checkbox"/>	<input type="checkbox"/>	<input checked="" type="checkbox"/>	<input type="checkbox"/>	<input checked="" type="checkbox"/>	<input type="checkbox"/>
Pharmacy (per quarter)	<input checked="" type="checkbox"/>	<input type="checkbox"/>	<input checked="" type="checkbox"/>	<input type="checkbox"/>	<input checked="" type="checkbox"/>	<input type="checkbox"/>	<input checked="" type="checkbox"/>	<input type="checkbox"/>	<input checked="" type="checkbox"/>	<input type="checkbox"/>
Auto Repair Shop (per quarter)	<input checked="" type="checkbox"/>	<input type="checkbox"/>	<input checked="" type="checkbox"/>	<input type="checkbox"/>	<input checked="" type="checkbox"/>	<input type="checkbox"/>	<input checked="" type="checkbox"/>	<input type="checkbox"/>	<input checked="" type="checkbox"/>	<input type="checkbox"/>

7. What is the route you take during construction to access the businesses/stores located in the influence area shown in the map?

	Use designated detour	Travel through the construction zone	Use alternate routes
Restaurants	<input type="checkbox"/>	<input type="checkbox"/>	<input type="checkbox"/>
Party/Liquor Store	<input type="checkbox"/>	<input type="checkbox"/>	<input type="checkbox"/>
Grocery Store	<input type="checkbox"/>	<input type="checkbox"/>	<input type="checkbox"/>
Gas Stations	<input type="checkbox"/>	<input type="checkbox"/>	<input type="checkbox"/>
Clothing Stores	<input type="checkbox"/>	<input type="checkbox"/>	<input type="checkbox"/>
Hardware Stores	<input type="checkbox"/>	<input type="checkbox"/>	<input type="checkbox"/>
Pharmacy	<input type="checkbox"/>	<input type="checkbox"/>	<input type="checkbox"/>
Auto Repair Shop	<input type="checkbox"/>	<input type="checkbox"/>	<input type="checkbox"/>

8. If the bridge is closed to traffic for two days, would you still travel to the area influenced by the construction shown in the map and continue with your “weekend” routine (shopping, eating, etc.)?

(Yes) (No)

9. If the bridge is closed to traffic for an extended duration (four months or longer), would you still travel into the area influenced by the construction shown in the map through detours or alternate routes to continue your “weekly” routine (shopping, eating, etc.)?

(Yes) (No)

Traffic:

10. What is your primary mode of transportation? _____

11. What is your commute duration per day?

Without construction: _____ With bridge construction: _____

12. What is your average commute distance per day?

Without construction: _____ With bridge construction: _____

	Strongly Disagree	Disagree	Neutral	Agree	Strongly Agree
13. The current roads in my community handled rush hour traffic very well during construction.					

Accidents:

	Strongly Disagree	Disagree	Neutral	Agree	Strongly Agree
14. There have been fewer accidents around the area affected by bridge construction.					
15. The average traveler is not at risk when driving through or by the bridge construction site.					
16. The posted speed allows for adequate access through the construction site.					

Public Opinion:

Please tell us your opinion in the following subjects:

17. Community needs to be better informed about upcoming bridge projects: _____

18. Community needs to be informed about construction progress: _____

19. Other subjects not covered above: _____

General Business Survey

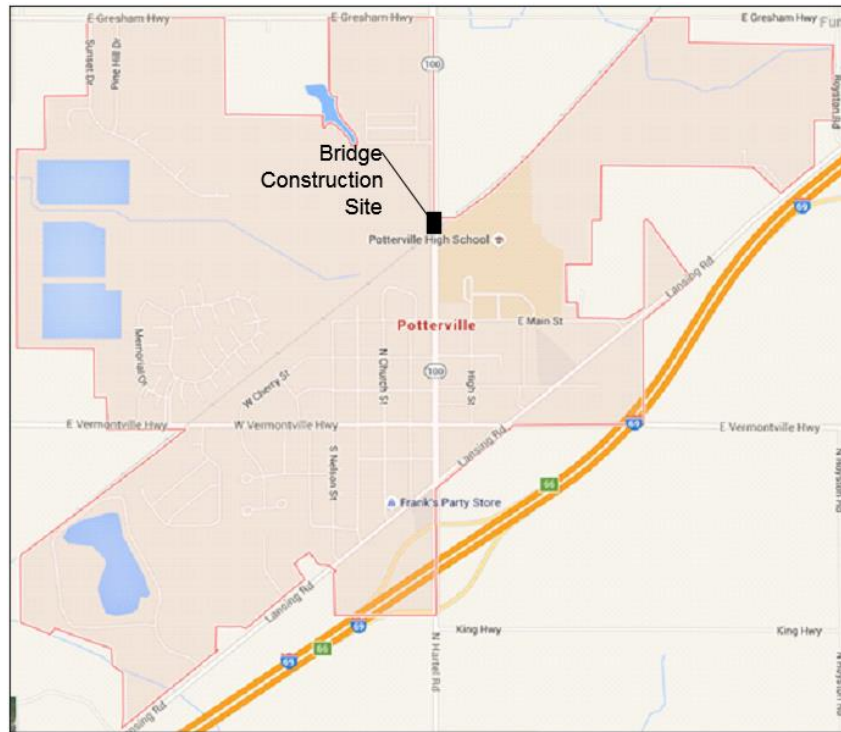
The purpose of this survey is to collect data in an effort to evaluate the economic impact on businesses within the vicinity of a bridge construction project. Your responses are very valuable to us. Your information, and the information you provide for us, will be kept confidential. Where needed, your data will only be used as summaries without referencing your business.

Date: _____

General Information

1. Business Type: _____

Please mark the location of your business on the map given below



2. State the number of employees: _____

3. Do you pay employees' travel expenses? (Yes) (No)

4. Did you notice an increase in employee travel expenses during the construction?
(Yes) (No)

If yes, please provide an estimate of the total additional expenses during construction?

(Circle the most appropriate answer)

Less than \$100	\$100-\$200	\$200-\$300	\$300-\$400	\$400-\$500	\$500 or more
-----------------	-------------	-------------	-------------	-------------	---------------

5. Does your business own vehicles other than commercial trucks?

(Yes) (No)

If yes, please provide an estimate of the total additional expenses during construction? (Circle the most appropriate answer)

\$0	Less than \$100	\$100-\$200	\$200-\$300	\$300-\$400	\$400-\$500	\$500 or more
-----	-----------------	-------------	-------------	-------------	-------------	---------------

Impact on Business Performance

In general, businesses are affected by the road closure for bridge construction activities. The economic impact on businesses that require direct customer access such as retail and grocery stores, restaurants, gas stations, etc., can be high. During a conventional bridge construction project (CC), road closure can last more than four months. With Accelerated Bridge Construction (ABC), roads are kept open most of the time and traffic disruption is limited from one or two days up to perhaps two weeks. ABC is expected to reduce the impact of construction on your business; however, the ABC project cost is (20%-40%) more than a conventional bridge project.

6. How would you describe the impact of loss of access to your business during construction?

(Circle the most appropriate answer)

Closed during the entire construction duration	Closed for a couple of days	Closed for several hours	No impact
--	-----------------------------	--------------------------	-----------

7. In your opinion, what percentage of customers are from the local community? (Circle the most appropriate answer)

During construction				
0%	25%	50%	75%	100%
After construction				
0%	25%	50%	75%	100%

8. In your opinion, compared to the sales before construction, what was the percent change of your gross sales?

During construction (Increase / Decrease)				
0%	25%	50%	75%	100%
After construction (Increase / Decrease)				
0%	25%	50%	75%	100%

9. In your opinion, what has been the overall impact to the other businesses around you?

During construction (Increase / Decrease)				
0%	25%	50%	75%	100%
After construction (Increase / Decrease)				
0%	25%	50%	75%	100%

10. In your opinion what could be the impact on your gross sales if road closure lasted for four months or more?

During construction (Increase / Decrease)				
0%	25%	50%	75%	100%
After construction (Increase / Decrease)				
0%	25%	50%	75%	100%

11. In your opinion, what could be the overall impact to the other businesses around you, if road closure lasted for four months or more?

During construction (Increase / Decrease)				
0%	25%	50%	75%	100%
After construction (Increase / Decrease)				
0%	25%	50%	75%	100%

12. Knowing the impact to your business during the ABC projects is important to us. Is there anything else that you would like us to know in regard to how these construction projects affect your business?

Thank you for your time. Your responses are valuable to us and we will incorporate them in our future work.

General Public Survey – Rationale for Survey Questions

The purpose of the survey is to collect site-specific data for quantifying economic impact of the bridge construction project. A second purpose is to educate community on ABC versus conventional construction. Direct estimation and opinion questions asked in the survey mostly aim at the data collection purposes. Informative paragraphs included in the survey are for educational purposes.

The survey and its rationale are divided into sections both for participant and analyst to track the flow conveniently.

Section: General Information

Question 1. Is your residence located within the area shaded on the following map? Yes/No

Rationale 1. The map included in the survey is used to determine if the participant lives in the area where direct access to the commercial center is interrupted during bridge construction. Instead of asking participant's address directly, asking to indicate the location on the map reduces the survey time as well helps protect their privacy.

After an educational paragraph, the area indicated in the second map shows the commercial center affected by construction. The hatched area on the map is called the influence area. The economic impact on the surrounding businesses is calculated by considering the businesses located in the influence area.

Section: Impact on Daily Life

Question 2: Did you use the designated detours around the construction site? Yes/No

Rationale 2: The aim is to calculate the percentage of people who used the designated detour and bring a clarification to the user cost calculations.

Question 3: If yes, did the detour provide adequate access to your destination? Yes/No

Rationale 3: The data is used to evaluate the effectiveness of the detour for providing access to pertinent destinations.

Question 4: If yes, was the detour route in good condition? Yes/No

Rationale 4: When traffic is diverted from a designated route, the detour might have to carry additional traffic volume. This may lead to accelerated deterioration of the pavement. The data is used to evaluate the condition of the route based on the participant's perception.

Question 5: Did the detour increase the cost or time of your commute? Yes/No

Rationale 5: This question is rather educational since the participant needs to reflect on the effect of the project and the detours have in monetary terms.

Question 6: How often do you go to the following businesses/stores inside the influence area shown in the map?

Rationale 6: In the quantification of business revenue loss, one of the parameters is the frequency (F) of customers accessing the businesses within the influence area. This question aims to collect site-specific data on frequency and the change in customer access before and during construction. The type of retail sale establishments are subject to change according to the types of businesses located in the influence area; hence, the content of the table needs to be customized based on the specific project for which the survey is conducted.

Question 7: What was the route you took during construction to access the businesses/stores located in the influence area shown in the map?

Rationale 7: This question is related with Question 2. If the participant did not use the designated detour, there are alternate ways to reach the destinations. The aim of the question is to see the percentage of participants choosing alternate ways to access different types of businesses.

Question 8: If the bridge is closed to traffic for two days, would you still travel to the area influenced by the construction shown in the map and continue with your "weekend" routine (shopping, eating, etc.)? Yes/No

Rationale 8: The data is used to calculate the percentage of people who would continue to use the same businesses during bridge closure. The result will be used in the quantification of business revenue loss due to ABC.

Question 9: If the bridge is closed to traffic for an extended duration (four months or longer), would you still travel into the area influenced by the construction shown in the map through detours or alternate routes to continue your “weekly” routine (shopping, eating, etc.)? Yes/No

Rationale 9: The data is used to calculate the percentage of people who are going to continue to use the same businesses during bridge closure. The result will be used in the quantification of business revenue loss due to CC.

Section: Traffic

Question 10: What is your primary mode of transportation?

Rationale 10: This question aims to relate all answers given to the questions by the participant with his/her mode of transportation. Since users of different transportation modes are not impacted at the same degree due to bridge construction, the participants’ answers provided for the rest of the questions would be evaluated accordingly.

Question 11: What is your commute duration per day? Without construction/With bridge construction

Rationale 11: This question aims at educating the participant on bridge construction impact on travel duration.

Question 12: What is your average commute distance per day? Without construction/With bridge construction.

Rationale 12: This question aims at educating the participant on bridge construction impact on distance of travel.

Question 13: The current roads in my community handled rush hour traffic very well during construction.

Rationale 13: Bridge construction projects can have negative impact on rush hour traffic due to change in traffic flow patterns. The aim of this question is to determine if the impact of congestion needs to be included in the economic impact analysis.

Section: Accidents

Question 14: There have been fewer accidents around the area affected by bridge construction.

Rationale 14: Even though users are more likely to be cautious while driving in construction zones, the number of crashes are higher because of other distractions. This question aims to measure the public opinion on crashes due to bridge construction.

Question 15: The average traveler is not at risk when driving through or by the bridge construction site.

Rationale 15: This question aims at evaluating work zone risks based on the public opinion.

Question 16: The posted speed allows for adequate access through the construction site and reduces the risk of accidents.

Rationale 16: The responses to this question can be utilized for quantifying user costs and environmental costs.

Section: Public Opinion

The following questions serve as an emotional outlet for the participant. If he/she can tell us what is his/her opinion (assuming that it is not being covered already in the survey), the feedback with this question can be incorporated in future studies.

Question 17: Community needs to be better informed about upcoming bridge projects.

Question 18: Community needs to be informed about construction progress.

Question 19: Other subjects not covered above.

General Business Survey – Rationale for Survey Questions

The purpose of the survey is to collect site-specific data for quantifying economic impact of the bridge construction project. A second purpose is to educate the business community on ABC versus conventional construction. Direct estimation and opinion questions mostly aim at the data collection purposes. Informative paragraphs included in the survey are for educating the businesses on accelerated bridge construction.

The survey and its rationale are divided into sections both for participant and analyst to track the flow conveniently.

Section: General Information

Question 1: State the type of business:

Rationale 1: This question defines the type of business since business revenue loss varies with the type of establishment.

The map shown is intended to find out whether the business is located in the influence area of a bridge construction. Instead of asking participant's address directly, asking to indicate the location on the map reduces the survey analysis time as well helps protect privacy.

Question 2: State the number of employees:

Rationale 2: The number of employees is used to determine the size of the business.

Question 3: Do you pay the employees' travel expenses? Yes/No

Rationale 3: If the business pays its employees' travel expenses, the data collected for this question and Question 4 together can be used as an indicator of the user cost, which is a parameter of the economic impact on the surrounding businesses.

Question 4: Did you notice an increase in employee travel expenses during the construction?
Yes/No

If yes, please provide an estimate of the total additional expenses during construction.

Rationale 4: Data retrieved from this question is used to obtain a monetary value estimation which can be used directly in economic impact on surrounding businesses.

Question 5: Does your business own vehicles other than commercial trucks? Yes/No

If yes, please provide an estimate of the total additional expenses during construction.

Rationale 5: Data retrieved from this question is used to obtain a monetary value estimation which can be used directly in economic impact on surrounding businesses.

Section: Impact on Business Performance

Question 6: How would you describe the impact of loss of access to your business during construction?

Rationale 6: The data is used to measure the impact of the loss of access to the business; hence, the loss of customers.

Question 7: In your opinion, what percentage of customers are from the local community? Please note during and after construction.

Rationale 7: The data is used to calculate the percentage of the local customer base of the business. The result, in conjunction with the local expenditure data, is used to calculate business revenue loss.

Question 8: In your opinion, compared to the sales before construction, what was the percent change of your gross sales? Please note during and after construction.

Rationale 8: The data is used to verify and compare the calculated change in the business revenue due to ABC.

Question 9: In your opinion, what has been the overall impact to the other businesses around you?

Rationale 9: The aim is to obtain an estimation of the overall impact of the ABC project on the surrounding businesses in the participant's point of view.

Question.10: In your opinion what could be the impact on your gross sales if road closure lasted for four months or more?

Rationale 10: The aim is to verify the change in business revenue due to CC.

Question 11: In your opinion, what could be the overall impact to the other businesses around you, if road closure lasted for four months or more?

Rationale 11: The data is used to calculate the overall impact of the CC project on the surrounding businesses in the participant's point of view.



MDOT RC-1618C



Research on Evaluation and Standardization of Accelerated Bridge Construction Techniques

**FINAL REPORT – SEPTEMBER 2017
(PART I)**



Department of Civil & Construction Engineering
College of Engineering and Applied Sciences
Western Michigan University

RESEARCH

1. Report No. RC-1618C	2. Government Accession No. N/A	3. MDOT Project Manager Corey Rogers, P.E. Mike Halloran, P.E.	
4. Title and Subtitle Research on Evaluation and Standardization of Accelerated Bridge Construction Techniques		5. Report Date 09/30/2017	
		6. Performing Organization Code N/A	
7. Author(s) Haluk Aktan, Ph.D., P.E. Upul Attanayake, Ph.D., P.E.		8. Performing Org. Report No. N/A	
		9. Performing Organization Name and Address Western Michigan University 1903 West Michigan Avenue Kalamazoo, Michigan 49008	
12. Sponsoring Agency Name and Address Michigan Department of Transportation Research Administration 8885 Ricks Road P.O. Box 30049 Lansing, MI 48909		10. Work Unit No. (TRAIS) N/A	
		11. Contract No. 2013-0069	
		11(a). Authorization No. Z4	
13. Type of Report & Period Covered Final Report 10/01/2015 – 09/30/2017		14. Sponsoring Agency Code N/A	
		15. Supplementary Notes	
16. Abstract The Michigan Department of Transportation (MDOT) has implemented several accelerated bridge construction (ABC) projects. MDOT evaluates bridge projects during the scoping process for ABC potential. During the earlier phase of this project, a framework and a multi-criteria decision support tool was developed to facilitate the scoping process by evaluating conventional construction (CC) and ABC. This Michigan-specific ABC Decision (Mi-ABCD) support tool only included prefabricated bridge elements and systems (PBES) as an ABC method. A follow up study expanded the framework to include slide-in bridge construction (SIBC) and self-propelled modular transporter (SPMT) moves. The goals for this project includes updating the Mi-ABCD decision-support tool to identify the optimal accelerated bridge replacement option for a specific site. ABC projects completed and being implemented by MDOT include PBES and SIBC. Hence, standardizing activities and associated operations of SIBC is also a goal of this project. The third goal is to develop user awareness tools that includes models for quantifying economic impact on surrounding communities and businesses due to bridge construction. The tasks completed during this project include (a) reviewing ABC activities nationally and monitoring ongoing ABC activities in Michigan, (b) updating the Mi-ABCD support platform to include bridge slides and SPMT moves along with PBES and CC, (c) developing user awareness tools with methodologies and models for quantifying economic impact on surrounding communities and businesses from the bridge projects, (d) developing a standardization process for the lateral slide, and (e) developing recommendations for implementing the updated version of Mi-ABCD, economic impact evaluation, and standardization process.			
17. Key Words Accelerated Bridge Construction, Scoping Framework, Economic Impact, Slide-in Bridge Construction, Standardizing SIBC		18. Distribution Statement No restrictions. This document is available to the public through the Michigan Department of Transportation.	
19. Security Classification - report Unclassified	20. Security Classification - page Unclassified	21. No. of Pages 151 (w/o appendices)	22. Price N/A

Research on Evaluation and Standardization of Accelerated Bridge Construction Techniques

**Final Report
(2015-2017)**

Project Manager: Mr. Corey Rogers, P.E. and Mr. Mike Halloran, P.E.

Submitted to:



Submitted by:

Haluk Aktan, Ph.D., P.E.
Professor
(269) 276 – 3206
haluk.aktan@wmich.edu

Upul Attanayake, Ph.D., P.E.
Associate Professor
(269) 276 – 3217
upul.attanayake@wmich.edu



Western Michigan University
Department of Civil & Construction Engineering
College of Engineering and Applied Sciences
Kalamazoo, MI 49008
Fax: (269) 276 – 3211

DISCLAIMER

“This publication is disseminated in the interest of information exchange. The Michigan Department of Transportation (hereinafter referred to as MDOT) expressly disclaims any liability, of any kind, or for any reason, that might otherwise arise out of any use of this publication or the information or data provided in the publication. MDOT further disclaims any responsibility for typographical errors or accuracy of the information provided or contained within this information. MDOT makes no warranties or representations whatsoever regarding the quality, content, completeness, suitability, adequacy, sequence, accuracy, or timeliness of the information and data provided, or that the contents represent standards, specifications, or regulations.”

ACKNOWLEDGEMENTS

This project is funded by the Michigan Department of Transportation. The authors would like to acknowledge the support and effort of Mr. David Juntunen and Mr. Corey Rogers for initiating this research. The authors also wish to acknowledge the continuing assistance of the Research Advisory Panel (RAP) members in contributing to the advancement of this study. Contribution of Dr. Abdul Wahed Mohammed, graduate students Ozan Utku Ridvanoglu and Funda Yavuz, and undergraduate student Turner Solterman towards the success of the project is greatly appreciated.

EXECUTIVE SUMMARY

The decision principles to guide the management, operation, and investments on eleven corridors in Michigan with national and international significance include strategies to reduce delays and minimize construction impacts. Accelerated bridge construction (ABC) is one such strategy employed by the Michigan Department of Transportation (MDOT). In 2008, MDOT initiated ABC implementation with a fully prefabricated full-depth deck panel bridge system, the Parkview Avenue Bridge. During the 2014-2015 period, four slide-in bridge construction (SIBC) projects were contracted and completed. Self-propelled modular transporter (SPMT) moves are another ABC method that MDOT is planning to implement in the near future.

MDOT evaluates every bridge project during the scoping process for ABC potential. During the earlier phase of this project, a framework and a multi-criteria decision-support tool was developed to facilitate the scoping process by evaluating conventional construction (CC) and ABC. This Michigan-specific ABC Decision-support (Mi-ABCD) tool only included prefabricated bridge elements and systems (PBES) as an ABC method. The next phase of the project expanded the framework to include slide-in bridge construction (SIBC) and self-propelled modular transporter (SPMT) moves.

The goals of this project were to:

- Advance the Mi-ABCD tool to help decide upon the most suitable ABC alternative.
- Develop ABC user awareness tools with models for quantifying economic impact on surrounding communities and businesses due to bridge construction.
- Standardize activities and associated operations of SIBC.

The specific tasks were as follows:

- Review ABC activities nationally and monitor ongoing ABC activities in Michigan.
- Develop a new version of the Mi-ABCD tool to include bridge slides and SPMT moves along with PBES and CC.
- Develop methods to increase user awareness of ABC projects and models for quantifying economic impact of bridge construction on surrounding communities and businesses.
- Develop a standardization process for lateral slide technique.
- Develop implementation recommendations.

STATE-OF-THE-ART AND STATE-OF-THE-PRACTICE LITERATURE REVIEW

The Federal Highway Administration (FHWA) established a web-based repository for ABC projects implemented in the US. Four SIBC projects that were completed during 2015 and 2016, not included in the repository, were also identified. Thus, a total of 28 SIBC projects were reviewed and compiled information about SIBC components and design parameters, temporary structure design, sequence of operations, constructability challenges, scoping parameters, foundation types, and cost.

Economic impact of roadway closure and safety within construction zones are considered when evaluating bridge construction methods for a specific site. ABC is often implemented over CC to minimize the roadway closure duration, which is defined as the mobility impact time. The strict time constraint is the part of ABC that achieves the main purpose - reduction in mobility impact time. These time constraints can be satisfied by using innovative techniques and additional construction activities, which lead to additional costs. Hence, the project cost of ABC is 6% to 21% greater than CC depending on site complexity, specified time constraints, and perceived risks. Even though the initial project cost is higher, ABC yields many benefits that can be quantified using site specific data or evaluated qualitatively based on experience. An objective of this project was to develop a model to rationally quantify the economic impacts on surrounding communities and businesses. Thus, the cost categories and the associated parameters were compiled through a literature review and are presented in Chapter 2 of this report.

THE MICHIGAN ACCELERATED BRIDGE CONSTRUCTION DECISION-SUPPORT (Mi-ABCD) TOOL

The decision-support framework developed during the earlier phase of this project is customized for implementation in Michigan, and supplemented with a guided software program titled Michigan Accelerated Bridge Construction Decision-support (Mi-ABCD) tool. In the first version of Mi-ABCD, ABC only encompassed PBES construction.

Other ABC technologies, such as SPMT and SIBC, are being increasingly implemented throughout the U.S. To address the need of assessing four bridge construction/replacement methods (CC, PBES, SPMT, and SIBC) per site, the decision support framework needed to be extended. During this project phase, the software was updated and an overview is presented in

chapter 3. A user manual was developed for the software and is presented as a supplemental document to this report.

ECONOMIC IMPACT ANALYSIS OF BRIDGE CONSTRUCTION

Economic impact of a roadway closure and safety within construction zone are two major parameters considered when evaluating bridge construction methods for a specific site. ABC benefits include reduced construction duration, maintenance of traffic cost, lifecycle cost, and reduced economic impact on surrounding communities and businesses, as well as the ability to address seasonal limitations. Chapter 4 presents a comprehensive model to quantify economic impact on surrounding communities and businesses. Economic impact is quantified using user cost, environmental cost, and business revenue change. User cost for passenger vehicles and environmental cost due to air pollution, water pollution, and climate change are considered for quantifying economic impact on surrounding communities. Economic impact on surrounding businesses is quantified by calculating user cost for trucks and business revenue change.

STANDARDIZATION OF SIBC

The construction process and procedures observed during US-131 over 3 Mile Road Bridge and M-50 over I-96 Bridge slides were discussed in a previous report. During both projects, maintaining bridge alignment during slide was observed as the primary complexity. In order to evaluate the parameters controlling the alignment during the move, numerical simulation of the US-131 over 3 Mile Road Bridge slide operation was performed during an earlier phase of this project. The simulation objective was to evaluate the influence of temporary substructure and friction between sliding surfaces on maintaining bridge alignment during a slide. In addition, slide operations with control feedback were simulated to demonstrate the impact of using state-of-the-practice hydraulic procedures in bridge slides. Finally, continuous and discrete sliding events were simulated to establish temporary substructure stresses. Also required for standardization is the instrumentation and monitoring of bridge slides to document structural response in order to establish forces that develop during the slide and to calibrate numerical models for further analysis. Chapter 5 of this report presents an overview of M-100 over the Canadian National (CN) railroad bridge slide operation, measurement of acceleration response of the bridge superstructure during

slide, numerical simulation of slide operation, and recommendations for standardizing SIBC design and operation.

SUMMARY AND CONCLUSIONS

Mi-ABCD Tool

The Mi-ABCD framework presented in Aktan and Attanayake (2013) was expanded to incorporate SIBC and SPMT move parameters. The updated framework is presented in *Research on Evaluation and Standardization of Accelerated Bridge Construction Techniques* (Aktan and Attanayake 2015). During this project, the updated framework was implemented in the Mi-ABCD tool for use during the scoping process to evaluate every bridge project and identify the most suitable construction alternative among CC, PBES, SIBC, and SPMT move.

Economic Impact Analysis

Traditionally, the savings in user cost from reduced mobility impact time are used to justify the additional cost of accelerated construction implementations. In addition to user cost, there are other costs of bridge projects to businesses and communities. Impact on businesses is primarily evaluated in terms of business revenue change. The impact on communities include disruption to mobility and adverse effects on environment.

A model was developed to quantify economic impact on surrounding communities and businesses from a bridge construction project. Data collection surveys for the model were designed to serve as a user awareness tool for the ABC project. The economic impact on surrounding communities and businesses model was implemented for M-100 over the CN railroad bridge replacement project in Potterville, Michigan. In order to perform a comparative analysis, SIBC was compared to bridge replacement with CC. The economic impacts on surrounding communities by SIBC and CC are \$731,083 and \$5,242,411 respectively. Accordingly, the impact on communities from CC is 7.2 times greater than the impact from SIBC. The economic impacts on surrounding businesses by SIBC and CC are \$50,313 and \$813,614 respectively. Hence, the impact on businesses by CC is almost 16 times greater than the impact by SIBC. The overall economic impact due to CC is 7.8 times greater than SIBC.

Standardizing SIBC Design and Operations

For SIBC, the new superstructure is constructed parallel and adjacent to the existing bridge on a temporary structure and moved into place with a sliding and an actuating system. SIBC can also be designed for maintaining traffic on the existing bridge and the new superstructure during construction. After completion of the new superstructure, traffic can be shifted and maintained on the new superstructure while preparing the site for bridge replacement. SIBC activities include (i) a temporary structure designed and constructed to support a new superstructure during construction and lateral slide, (ii) a sliding system to provide interaction surfaces and a path during slide, and (iii) an actuating system to provide forces for initiating and maintaining bridge slide. Each SIBC implementation has been unique so far. Uncertainties include slide properties contributing to friction between surfaces, pushing and pulling force levels, and monitoring and controlling the force levels. Standardization purpose is to develop repeatable procedures for SIBC. Another aspect of standardization is developing an understanding of the structural system response during slide activities.

Twenty-eight (28) SIBC projects were reviewed and data was compiled on SIBC components and design parameters, temporary structure design, sequence of operations, constructability challenges, scoping parameters, foundation types, and cost. In addition, a remote monitoring system with accelerometers was fabricated and implemented during M-100 over the CN railroad bridge slide. The same project detail was used as the prototype for the FE slide simulation. Sliding operation and roller jamming on the railing girder were considered. In addition, impact of actuator jerk during the deceleration of a push event, and load transfer at the connection between temporary structure and permanent abutments were evaluated. After reviewing 28 SIBC project activities, monitoring SIBC activities in Michigan, monitoring acceleration response during bridge slide using rollers, and the FE simulation of SIBC, a set of flowcharts depicting an overview of SIBC design, sliding system design with *Teflon* pads and rollers, and an actuating system design was developed. The efforts and findings of this task are presented in chapter 5.

TABLE OF CONTENTS

ACKNOWLEDGEMENTS	v
EXECUTIVE SUMMARY	vi
TABLE OF CONTENTS	xi
LIST OF TABLES	xiv
LIST OF FIGURES	xv
1 Introduction.....	1
1.1 Overview.....	1
1.2 Objective and Tasks.....	1
1.3 Report Organization.....	2
2 State-of-the-Art and State-of-the-Practice Literature Review.....	4
2.1 Overview.....	4
2.2 Economic Impact Analyses.....	4
2.2.1 Overview.....	4
2.2.2 User Cost.....	5
2.2.3 Environmental Cost	8
2.2.4 Business Revenue Change.....	13
2.2.5 Data Collection Tools for Economic Impact Analysis	14
2.3 Bridge Slide Activities.....	15
2.3.1 Sliding System	16
2.3.2 Actuating System.....	23
2.4 Bridge Slide Monitoring Technology	27
3 The Michigan Accelerated Bridge Construction Decision-support (Mi-ABCD) Tool.....	32
3.1 Overview.....	32
3.2 The Mi-ABCD Process.....	32
3.2.1 Sample Popup Menus and Datasheet.....	32
3.2.2 User Menus	34
3.2.3 Implementation Process.....	34
3.3 Summary.....	45

4	Economic Impact Analysis of Bridge Construction	47
4.1	Overview.....	47
4.2	Economic Impact on Surrounding Communities.....	48
4.2.1	User Cost.....	48
4.2.2	Environmental Cost	50
4.3	Economic Impact on Surrounding Businesses.....	53
4.3.1	User Cost.....	53
4.3.2	Business Revenue Change.....	54
4.3.3	Case Study – SIBC in Pottersville, MI.....	55
4.4	Summary	67
5	Standardization of SIBC	70
5.1	Overview.....	70
5.2	M-100 over CN Railroad SIBC Project.....	70
5.2.1	Site Characteristic and Bridge Construction Method Selection	71
5.2.2	Existing and Replacement Bridge Details	71
5.2.3	Construction and Maintenance of Traffic	73
5.2.4	Pre-sliding Operations.....	75
5.2.5	Sliding Operations	76
5.2.6	Post-sliding Operations.....	78
5.3	Instrumentation and Monitoring of Bridge Slide.....	81
5.3.1	Overview.....	81
5.3.2	Instrumentation Planning and Design.....	81
5.3.3	Data Acquisition System.....	83
5.3.4	Field Implementation	83
5.3.5	Data Analysis.....	85
5.3.6	Summary	90
5.4	Finite Element Simulation of Bridge Slide.....	92
5.4.1	Bridge Geometry, FE Modelling Parameters, and Loads	92
5.4.2	Analysis Results.....	101
5.4.3	Summary	106
5.5	Standardizing SIBC Procedures.....	107
5.5.1	Overview of SIBC Design.....	107
5.5.2	Sliding System Design Procedure.....	108

5.5.3	Actuating System Design Procedure	115
5.5.4	Summary	119
6	Summary, Conclusions, and Recommendations.....	120
6.1	Summary and Conclusions	120
6.1.1	Mi-ABCD Support Tool	120
6.1.2	Economic Impact Analysis	121
6.1.3	Standardizing SIBC Design and Operations.....	123
6.2	Recommendations.....	126
7	References.....	128
APPENDIX A: Abbreviations		
APPENDIX B: Notations		
APPENDIX C: Community and Business Survey Templates		

LIST OF TABLES

Table 2-1. SIBC Projects Completed during Year 2015-2016	4
Table 2-2. ABC Benefit Parameters (Aktan and Attanayake 2015).....	5
Table 2-3. Value of Travel Time for 2015.....	6
Table 2-4. Average Cost per Accident in Michigan for 2015.....	7
Table 2-5. Number of Accidents in Michigan during 2014.....	7
Table 2-6. Vehicle Types Involved in Accidents during 2014	7
Table 2-7. Typical Work Zone CMFs.....	8
Table 2-8. Emission Rates of Passenger Gasoline Vehicles and Diesel Trucks.....	9
Table 2-9. Unit Costs of Pollutants for 2015	10
Table 2-10. Speed Correction Factors for Arterials/Collectors	10
Table 2-11. General Cost as a Percentage of Health Care Cost.....	11
Table 2-12. Unit Cost of Water Pollution due to Transportation Activities for 2015	11
Table 2-13. EPA Truck Classification by Gross Weight.....	12
Table 2-14. FHWA Truck Classification by Gross Weight.....	12
Table 2-15. MDOT Truck Classification by Gross Weight.....	12
Table 2-16. Global Warming Potentials (GWPs) of Greenhouse Gases (GHGs)	12
Table 2-17. GHG Emissions by Vehicle Type	13
Table 4-1. General Cost as an Average Percentage of Health Care Cost	52
Table 4-2. General Parameters of the Bridge Project	56
Table 4-3. User Cost Parameters of Economic Impact on Surrounding Communities	60
Table 4-4. User Cost to Surrounding Communities.....	60
Table 4-5. Environmental Cost Parameters of Economic Impact on Surrounding Communities	62
Table 4-6. Environmental Cost to Surrounding Communities	62
Table 4-7. User Cost Parameters of Economic Impact on Surrounding Businesses	63
Table 4-8. User Cost to Surrounding Businesses.....	64
Table 4-9. Business Revenue Change Parameters.....	65
Table 4-10. Business Revenue Change.....	66
Table 4-11. Economic Impact on Surrounding Communities and Businesses.....	69
Table 5-1. Components Included in the Model	93
Table 5-2. Material Properties	96

LIST OF FIGURES

Figure 2-1. Environmental cost categories	9
Figure 2-2. A typical view prior to slide.....	16
Figure 2-3. Bridge sliding (a) onto permanent bearings and (b) on railing girders	17
Figure 2-4. Vertical lifting arrangement	18
Figure 2-5. Temporary structure and permanent substructure positions	18
Figure 2-6. Sliding mechanism with rollers, components, and orientation	19
Figure 2-7. Transverse restraint with <i>Teflon</i> pads	20
Figure 2-8. Transverse restraints with rollers	21
Figure 2-9. Vertical jacking configuration.....	23
Figure 2-10. Hydraulic system.....	24
Figure 2-11. Hydraulic cylinders utilized in completed SIBC projects.....	25
Figure 2-12. Use of a prestressing jack for pulling a bridge.....	25
Figure 2-13. Prestressing jack with pushing method.....	26
Figure 2-14. Monitoring of US-131 over 3 Mile Road bridge slide.....	29
Figure 2-15. Instrumentation of M-50 Road over I-96 bridge slide	30
Figure 3-1. Sample popup menus and datasheet.....	33
Figure 3-2. User menus.....	34
Figure 3-3. <i>Project Information</i> datasheet.....	35
Figure 3-4. Decision-making parameters for highway over highway project	36
Figure 3-5. <i>Site Specific Data</i> datasheet	37
Figure 3-6. <i>Traffic Data</i> datasheet.....	38
Figure 3-7. <i>Cost Data</i> datasheet.....	39
Figure 3-8. <i>Preference Ratings</i> datasheet	41
Figure 3-9. <i>Preference Ratings</i> datasheet when accessed as an <i>Advanced User</i>	42
Figure 3-10. Results in chart format	43
Figure 3-11. Results in tabular format	44
Figure 4-1. The cost categories for economic impact analysis of bridge construction.....	48
Figure 4-2. Length of the affected roadway due to bridge construction (L).....	57
Figure 4-3. Detour and the closed road segment for passenger vehicles.....	57
Figure 4-4. Detour and closed road segment for trucks.....	58

Figure 4-5. CO ₂ Emissions vs speed for gasoline passenger vehicles.....	61
Figure 4-6. Influence area of the bridge project (Commercial center of Potterville)	65
Figure 4-7. Influence area and the area without direct access to the influence area.....	66
Figure 5-1. Bridge location (Google Earth).....	71
Figure 5-2. M-100 over CN railroad bridge.....	72
Figure 5-3. Elevation view of the new bridge.....	72
Figure 5-4. Temporary structure	73
Figure 5-5. New superstructure at temporary location	74
Figure 5-6. New superstructure on temporary elastomeric bearings	74
Figure 5-7. Replacement superstructure as the temporary runaround for traffic.....	75
Figure 5-8. Uninterrupted railway operation during bridge construction and slide	75
Figure 5-9. Sliding and actuating system components	76
Figure 5-10. Sliding operation sequence	77
Figure 5-11. Superstructure position at 8:15 AM and returnwall grinding to provide adequate clearance to complete slide	78
Figure 5-12. Primary steps involved in placing superstructure on permanent bearings.....	79
Figure 5-13. Placement of approach slab.....	80
Figure 5-14. View of M-100 over CN railroad bridge site as of December 8, 2015.....	80
Figure 5-15. Instrumentation plan.....	82
Figure 5-16. Rigid fixture for mounting accelerometers	82
Figure 5-17. Equipment assembly in the box	83
Figure 5-18. Site layout and position of sensors and monitoring crew	84
Figure 5-19. Instrumentation setup on the bridge.....	84
Figure 5-20. Acceleration histories during onset of first five push events	86
Figure 5-21. Peak accelerations recorded during the first five events.....	87
Figure 5-22. Free body diagram of bridge superstructure in motion.....	88
Figure 5-23. Variation of net sliding forces in terms of a percentage of superstructure weight .	89
Figure 5-24. Variation of transverse force and difference in friction coefficients	90
Figure 5-25. M-100 over CN railroad bridge superstructure on the temporary structure.....	92
Figure 5-26. CAD model of the bridge superstructure and temporary structure.....	93

Figure 5-27. A rigid block to provide a sudden restraint to bearing movement (used for simulation of jamming).....	94
Figure 5-28. Cross-section of the superstructure	94
Figure 5-29. Superstructure, temporary structure, and sliding mechanism detail	95
Figure 5-30. FE representation of structural and sliding details.....	97
Figure 5-31. A sliding track and roller assemblies (a) geometry of a roller assembly in a channel and (b) geometric representation in the model	98
Figure 5-32. Boundary conditions assigned for extended piles and permanent substructure.....	98
Figure 5-33. Actuating force history.....	99
Figure 5-34. Actuating force histories with different jerks.....	100
Figure 5-35. Variation of displacement and velocity of superstructure against time at each sliding track.....	101
Figure 5-36. Impact forces developed at the points of contact due to jamming of the front roller on the north sliding track	102
Figure 5-37. Reaction forces at the supports of temporary structure and permanent abutment	102
Figure 5-38. Actuator piston motion histories	104
Figure 5-39. Sliding and reaction force histories.....	105
Figure 5-40. An overview of SIBC design	108
Figure 5-41. Sliding system design procedure.....	109
Figure 5-42. Sliding shoe and <i>Teflon</i> bearing pad design procedure.....	111
Figure 5-43. Design procedure for a sliding mechanism with rollers.....	113
Figure 5-44. A roller assembly unit used for bridge slide (Source: Hilman 2016)	114
Figure 5-45. Hydraulic operation system design procedure	116
Figure 5-46. Actuating mechanism design procedure	118

1 INTRODUCTION

1.1 OVERVIEW

The Michigan Department of Transportation (MDOT) has implemented several accelerated bridge construction (ABC) projects. MDOT evaluates every bridge project for ABC during the scoping process. Among ABC methods, prefabricated bridge elements and systems (PBES), slide-in bridge construction (SIBC), and self-propelled modular transporter (SPMT) moves are considered. ABC projects completed and being implemented by MDOT include prefabricated bridge elements and systems (PBES) and slide-in bridge construction (SIBC).

Aktan and Attanayake (2013) developed recommendations towards standardizing PBES by classifying elements, systems, and connections for Michigan. The standardization process and the recommendations are presented in the MDOT report *Improving Bridges with Prefabricated Precast Concrete Systems*. Aktan and Attanayake (2015) also developed scoping guidelines for ABC alternatives, recommendations towards standardizing the operations for bridge slides, and guidelines for building foundations while the existing bridge is in service. The project effort, guidelines, and recommendations are presented in MDOT report *Research on Evaluation and Standardization of Accelerated Bridge Construction Techniques*. The current project was initiated to advance the accelerated bridge construction by implementing an ABC decision support framework to provide a comparison of four bridge construction/replacement methods, quantifying economic impact on surrounding communities and businesses due to bridge construction by generating awareness and collecting input from users who are directly affected by the bridge project, and developing guidelines for standardizing SIBC (a.k.a. lateral slide) operations; specifically, sliding mechanisms and actuating systems.

1.2 OBJECTIVE AND TASKS

The objective is to document, evaluate, and verify procedures of bridge replacement utilizing slides and SMPT moves with the goal of leveraging the best practices for MDOT implementations. The specific objectives of the study are as follows:

- 1) Update the Mi-ABCD tool to help decide upon the most suitable accelerated bridge replacement option for a specific site.

- 2) Develop ABC user awareness tools with models for quantifying economic impact on surrounding communities and businesses due to bridge construction.
- 3) Standardize activities and associated operations of bridge slides.

To achieve the objectives, the project was organized into five tasks as follows:

- 1) Review ABC activities nationally and monitor ongoing ABC activities in Michigan.
- 2) Develop a new version of the Mi-ABCD tool to include bridge slides and SPMT moves, along with PBES and CC.
- 3) Develop methods to increase user awareness of ABC projects and models for quantifying economic impact of bridge construction on surrounding communities and businesses.
- 4) Develop a standardization process for lateral slide technique.
- 5) Develop implementation recommendations.

1.3 REPORT ORGANIZATION

This report is organized into 7 chapters.

Chapter 1 includes the introduction and overview of the research project.

Chapter 2 provides a list of SIBC projects completed by other highway agencies and analyzed for a detailed understanding of specific activities. This chapter also describes economic impact analysis and bridge slide monitoring literature.

Chapter 3 describes the updated version of the Michigan-specific ABC decision-support platform for comparing four bridge construction/replacement methods (CC, PBES, SPMT, and SIBC) as part of the project scoping process for a site.

Chapter 4 provides a quantification model for economic impact on surrounding community and businesses during bridge construction. ABC implementations obviously carry a higher initial cost. Traditionally, the benefits are often represented as user cost. This chapter provides a detailed breakdown for cost categories and their quantification methods associated with economic impact analysis.

Chapter 5 includes the analysis of slide activities and recommendations for the standardization of bridge slides. The components of this chapter include a detailed review of the activities and implementations of a recent MDOT SIBC project, monitoring data and analysis

results, simulations of bridge moves, and a process of standardizing SIBC activities and associated operations.

Chapter 6 presents the comprehensive results, recommendations, and proposed further work on this topic.

Chapter 7 includes the cited references.

2 STATE-OF-THE-ART AND STATE-OF-THE-PRACTICE LITERATURE REVIEW

2.1 OVERVIEW

FHWA has developed a web-based repository for ABC projects implemented in the US. The repository consists of folders containing information and data on each ABC project (FHWA 2015a). The projects listed in the repository and additional ABC projects identified through literature were reviewed and reported by Aktan and Attanayake (2015). The repository has not been updated since 2015. The research team identified four additional slide-in bridge construction (SIBC) projects that were completed during 2015 and 2016 (Table 2-1). So far, 27 SIBC projects were implemented in the U.S. (Ridvanoglu 2016). One of the objectives of this project is to develop procedures for standardizing activities and associated operations of bridge slides. Towards this objective, 28 SIBC projects (i.e., 27 from the U.S. and one from Ontario, Canada) were reviewed to compile information about SIBC components and design parameters, temporary structure design, sequence of operations, constructability challenges, scoping parameters, foundation types, and cost.

Table 2-1. SIBC Projects Completed during Year 2015-2016

No.	Project Name	State	Year
1	Ross Clarke Circle Bridge	Alabama	2016
2	Sacaton Bridge	Arizona	2015
3	M-100 over Canadian National Railway Bridge	Michigan	2015
4	SR 201 Bridge	Utah	2015

2.2 ECONOMIC IMPACT ANALYSES

2.2.1 Overview

Economic impact of roadway closure and safety within construction zones are considered when evaluating bridge construction methods for a specific site. ABC is implemented over CC to minimize the roadway closure duration, which is called the mobility impact time. The strict time constraints will always be the part of ABC to achieve the main purpose: reduction in mobility impact time. These time constraints can be satisfied by using innovative techniques and additional work, which lead to additional costs. Hence, the project cost of ABC is 6% to 21% greater than CC depending on site complexity, time constraints, and perceived risks (Aktan and Attanayake 2015). Even though the initial project cost is higher, ABC yields many benefits that can be quantified using site specific data or evaluated qualitatively based on experience. Traditionally,

the savings in user cost from reduced mobility impact time is defined as a benefit of ABC implementations. In addition to the user cost, additional quantitative and qualitative benefit parameters are described in Table 2-2 (Aktan and Attanayake 2015). In Table 2-2, the economic impact on surrounding communities was quantified using the county job multiplier. The economic impact on surrounding businesses was evaluated qualitatively after considering the businesses that are potentially affected by construction activities. In this project, the goal is to develop a model to rationally quantify the economic impacts on surrounding communities and businesses. For that purpose, the project impacts are grouped under three major cost categories (a) user cost, (b) environmental cost, and (c) business revenue change (ARE 2010; Allouche and Gilchrist 2004; Delucci 2000; FHWA 1997). The cost categories and the associated parameters are described in the following sections.

Table 2-2. ABC Benefit Parameters (Aktan and Attanayake 2015)

	Benefit Parameters
Quantitative Parameters	<ol style="list-style-type: none"> 1. Maintenance of traffic (MOT) cost 2. Life-cycle cost 3. User cost during construction 4. Economic impact on surrounding communities 5. Economic impact on surrounding businesses
Qualitative Parameters	<ol style="list-style-type: none"> 1. Stakeholder's limitations 2. Seasonal limitations 3. Site condition complexities 4. Environmental protection near and within the site

2.2.2 User Cost

User cost is the added delay cost, vehicle operating cost, and accident cost to road users resulting from construction, maintenance, or rehabilitation activities (NJDOT 2001). One objective of this project is to quantify the bridge construction economic impact on surrounding businesses and communities. User cost is formulated for business and personal travel separately (Forkenbrock and Weisbrod 2001).

User cost is typically used for evaluating MOT alternatives. MDOT is using a comprehensive tool, which is called CO³, to evaluate level of service (LOS) and cost impacts on users during each MOT alternative considered for a project (MDOT 2016a). Input variables of CO³ include per hour user costs for passenger vehicles and trucks, work zone length, detour length, speed limits, roadway capacity, and demand estimations based on foreseen lane closures. CO³ calculates user cost per hour due to delays, vehicle operation, and accidents; as well prorates costs for the year of

construction based on the Consumer Price Index (CPI) as defined in FHWA (1998). CO³ output is a comprehensive report that includes total user cost, average delay costs, maximum delay, average delay, the number of vehicles detoured, average delay per diverted vehicle, lane closure days, labor cost, project cost, etc. Total user cost calculated by CO³ is a summation of costs from increased travel distance via detour and delays due to work zone or congestion. The output of CO³ does not present user costs for personal travelers and businesses separately.

2.2.2.1 Delay Cost

Travel delay cost is calculated by the hourly rate per person (i.e., the cost of time spent on transport) (Litman 2013). Hourly rate per person is calculated from the hourly median household income for personal travel and the median hourly wage for business travel. The hourly rate for drivers is given in USDOT (2014). In order to evaluate delay cost, the hourly rate needs to be defined for the passengers as well. According to Litman (2013), the hourly rate for an adult passenger is 70% of the driver rate. These values are prorated to the 2015 dollar value using CPI and shown in Table 2-3.

Table 2-3. Value of Travel Time for 2015

Category	Hourly rate per person (2015 \$)
Local Travel	
Personal - driver	12.67
Passenger	8.87
Business - driver	24.82
Intercity Travel	
Personal - driver	17.72
Passenger	12.40
Business - driver	24.82

2.2.2.2 Vehicle Operating Cost

Vehicle operating cost represents direct expenses to own and maintain a vehicle. According to AAA (2015), an average hourly operating cost for a passenger vehicle is \$0.58/mile. This amount covers the cost of fuel, maintenance, tires, insurance, license, registration, taxes, depreciation, and finances. ATRI (2014) provides an average hourly vehicle operating cost of \$1.076/mile for trucks in the Midwest region of the U.S., which includes Michigan.

2.2.2.3 Accident Cost

Accident cost accounts for the economic impact on individuals due to injury, loss of life, and property damage (Kostyniuk et al. 2011). The estimated unit monetary value of injury and property damage is based on 2009 crash and crime incidence data from Michigan (Kostyniuk et al. (2011)). These values were converted into 2015 dollar equivalents and presented in Table 2-4.

Table 2-4. Average Cost per Accident in Michigan for 2015

	Fatal	Serious injury	Moderate injury	Minor injury	Property damage only
Vehicle damage	15,756	6,913	5,498	4,922	1,808
Comprehensive cost	3,937,034	250,314	74,589	43,501	4,022

Two other parameters for accident cost calculation are needed. These are the number of accidents in a jurisdiction and the total miles travelled in a year. Table 2-5 shows the number of accidents and the associated property damages in Michigan. The data was obtained from the 2014 records of the Michigan Office of Highway Safety and Planning (MOHSP 2014). The annual miles travelled by passenger vehicles and trucks in Michigan during year 2014 was 97.1 billion (MDOT 2016b). Percentage of passenger vehicles and trucks travelled on Michigan roads is also required in order to calculate the accident costs for passenger vehicles and trucks. As per MOHSP (2014) data, these percentages are shown in Table 2-6. Accident rate is accounted for passenger vehicles and trucks separately considering their involvement percentages in accidents.

Table 2-5. Number of Accidents in Michigan during 2014

Fatal	Injury	Property damage
806	52,523	245,370

Table 2-6. Vehicle Types Involved in Accidents during 2014

	Fatal	Injury	Property damage
Passenger vehicles (%)	61.2	77.9	77.7
Trucks (%)	7.7	2.4	2.7

In order to calculate accident severity within a work zone, a crash modification factor (CMF) is used, as shown in Eq. 2-1 (FHWA 2014a). Typical work zone CMFs, defined in FHWA (2015b), are given in Table 2-7.

$$A_a = CMF \cdot A_n \quad (2-1)$$

where 'A_n' is accident rate and 'A_a' is accident rate due to work zone.

Table 2-7. Typical Work Zone CMFs

Accident severity	CMF
Injury	1.6
Property damage	1.9
Average	1.77

During ABC, vehicles travel through the work zone as well as the detour. The duration of travel depends on the Traffic Management Plan (TMP), which is developed for the project by considering the specific ABC method. Hence, accident cost can be estimated using crash data, CMF, and the data available in the Traffic Management Plan.

2.2.3 Environmental Cost

Reduced speed and detours during construction contribute to air pollution emissions and fuel and pollutant discharge. Emissions are primarily responsible for air pollution and climate change while the discharge is responsible for water pollution. In this respect, the environmental impact of transportation is divided into three categories of i) air pollution, ii) water pollution, and iii) climate change (Delucci 2000). These three categories can be assigned a monetary value, and environmental impact is calculated as a cost. Based on the information provided in Maibach et al. (2008); Muller and Mendelson (2007); Delucci (2000); Forkenbrock (1999); and Bein (1997), impact of air pollution is calculated as part of health care cost and general cost. As shown in Figure 2-1, general cost accounts for reduced visibility, agricultural damage, property damage, and forestry damage.

2.2.3.1 Air Pollution

Air pollution is caused by the emission of pollutants such as carbon monoxide (*CO*), nitrogen dioxide (*NO₂*), particulate matter (*PM*), and volatile organic compounds (*VOC*). Impact of air pollution is quantified using health care cost and general cost. However, the health care cost is by far the most significant cost category (Maibach et al. 2008).

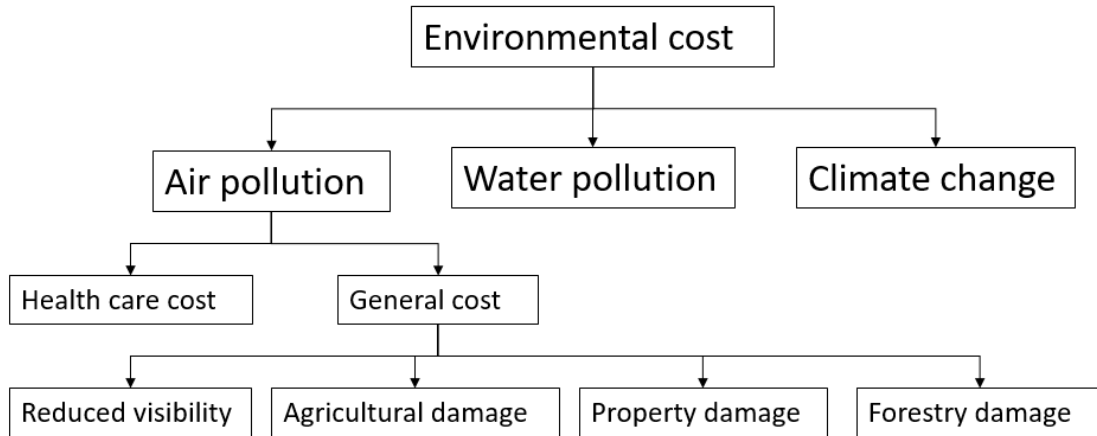


Figure 2-1. Environmental cost categories

2.2.3.1.1 Health Care Cost

Air pollution causes a broad spectrum of health impacts on people including acute and chronic diseases, premature mortality, and cardiovascular illnesses (Cohen et al. 2005; Craig et al. 2005; and Gwilliam et al. 2004). The Environmental Protection Agency (EPA) provides average emission rates of pollutants from passenger gasoline vehicles and diesel trucks (Table 2-8). The values are provided for passenger gasoline vehicles and diesel trucks separately because 99% of passenger vehicles run on gasoline, while 80% of trucks run on diesel (USDOT 2015). These emission rates correspond to a 27.6 mph average speed (EPA 2008a and EPA 2008b).

Table 2-8. Emission Rates of Passenger Gasoline Vehicles and Diesel Trucks

Pollutants	Passenger vehicles (10 ⁻³ lbs/mile)	Trucks (10 ⁻³ lbs/mile)
VOC	2.2708	0.9855
CO	20.7235	5.0949
NO ₂	1.5278	18.9884
PM _{2.5}	0.0090	0.4453
PM ₁₀	0.0097	0.4828

McCubbin and Delucci (1999) present the associated unit costs of pollutants (Table 2-9). Hence, the impact of air pollution on human health can be monetized using emission rates, unit costs, and the distance travelled.

Table 2-9. Unit Costs of Pollutants for 2015

Pollutants	Lower bound (\$/lbs)	Upper bound (\$/lbs)
VOC	0.079	0.908
CO	0.008	0.071
NO ₂	0.924	13.646
PM _{2.5}	8.224	125.641
PM ₁₀	7.695	105.586

PM_{2.5} represents particles less than 2.5 microns in aerodynamic diameter; PM₁₀ represents particles between 2.5 microns and 10 microns in aerodynamic diameter.

The emission rate is a function of speed limit. Therefore, the change in emission rates should be quantified by utilizing speed correction factors (EPA 2001). Table 2-10 from the EPA (2001) shows the speed correction factors (SCFs) for 2 pollutants from passenger gasoline vehicles. Emission rate of other pollutants do not appear to be speed sensitive (EPA 2011; Yao et al. 2014).

Table 2-10. Speed Correction Factors for Arterials/Collectors

Average speed (mph)	CO	NO₂
10	1.35	1.52
15	1.13	1.28
20	1.02	1.16
25	0.97	1.08
30	0.95	1.04
35	0.98	1.02
40	1.06	1.04
45	1.14	1.07
50	1.21	1.09
55	1.29	1.12
60	1.37	1.15
65	1.45	1.17

Commuters travel extra miles when a detour is required. As a result, emission of pollutants released to the environment is expected to increase. However, based on the speed correction factor, emission rates are lower if the commuters travel at a speed ranging from 25 mph to 35 mph instead of travelling at typical highway speeds.

2.2.3.1.2 General Cost

Non-health care related cost from air pollution is defined as the general cost, which includes impact of reduced visibility and damage to agriculture, property, and forestry. The estimate for reduced visibility cost depends on the asset value of homes; agricultural damage cost depends on crop shortfalls; property damage cost depends on discoloration and building facade damage; and forestry damage cost depends on the decline in timber growth. Table 2-11 shows the upper and lower bounds of these costs as a percentage of the health care cost (Delucci and McCubbin 2010).

Table 2-11. General Cost as a Percentage of Health Care Cost

General Cost Category	General Cost (% of Health Care Cost)	
	Lower bound	Upper bound
Reduced visibility	10	19
Agricultural damage	2	17
Property damage	3	5
Forestry damage	1	1

2.2.3.2 Water Pollution

Fuel and chemicals discharged or spilled from vehicles leak into oceans, rivers, lakes, and groundwater. Water polluted with fuels and chemicals impacts human health and wildlife, and can also corrode materials and despoil scenic recreation areas. Delucci and McCubbin (2010) proposed quantifying the impact of water contamination from passenger vehicles in terms of passenger miles travelled (pmt) and trucks in terms of ton-miles (tm). Table 2-12 shows the unit cost of water pollution from these transportation activities.

Table 2-12. Unit Cost of Water Pollution due to Transportation Activities for 2015

Vehicle type	Unit Cost of Water Pollution	
	Lower bound	Upper bound
Passenger vehicle (\$ per pmt)	0.01650	0.060
Truck (\$ per tm)	0.00354	0.060

Calculation of water pollution cost requires truck weight. For this purpose, truck classification and gross vehicle weights presented by the EPA, FHWA, or respective DOTs can be used. As an example, Table 2-13 shows truck classification and gross vehicle weights presented by the EPA (2011). Similarly, Table 2-14 and Table 2-15 present truck classification by USDOE (2014) and MDOT (2013). Even though many different classifications exist, use of state specific truck configurations is feasible because truck counts and weights can be access through weigh-in motion (WIM) data records.

Table 2-13. EPA Truck Classification by Gross Weight

Truck classification	Gross vehicle weight interval (lbs)
Heavy duty vehicle 2b	8,501-10,000
Heavy duty vehicle 3	10,001-14,000
Heavy duty vehicle 4	14,001-16,000
Heavy duty vehicle 5	16,001-19,500
Heavy duty vehicle 6	19,501-26,000
Heavy duty vehicle 7	26,001-33,000
Heavy duty vehicle 8	heavier than 33,001

Table 2-14. FHWA Truck Classification by Gross Weight

Truck classification	Gross vehicle weight interval (lbs)
Class 3	10,001-14,000
Class 4	14,001-16,000
Class 5	16,001-19,500
Class 6	19,501-26,000
Class 7	26,001-33,000
Class 8	heavier than 33,001

Table 2-15. MDOT Truck Classification by Gross Weight

Truck classification	Gross vehicle weight (lbs)
Medium truck	32,000
Standard semi-trailer	73,000
Standard interstate semi-trailer	80,000
Michigan 8-axle log truck	125,000
Michigan multi-axle truck	150,000
Michigan multi-axle single trailer	150,000

2.2.3.3 Climate Change

Vehicle emissions that contribute to climate change are called greenhouse gases (GHGs), consisting of CO₂, CH₄, and N₂O from tailpipes, and chlorofluorocarbon (CFC) leaking from air conditioners (EPA 2014). Greenhouse gases are generally aggregated to a common measure known as the global warming potential (GWP). The international standard of this measurement is to express greenhouse gases in terms of equivalent CO₂. This allows the comparing of impacts of different greenhouse gases on the environment. Table 2-16 shows the GWP of typical GHGs contributed by the transportation industry. As an example, GWP of CH₄ is 28 times greater than that of CO₂.

Table 2-16. Global Warming Potentials (GWPs) of Greenhouse Gases (GHGs)

Greenhouse Gases (GHGs)	Global Warming Potential (GWP)
Carbon Dioxide (CO ₂)	1
Methane (CH ₄)	28
Nitrous Oxide (N ₂ O)	298
Chlorofluorocarbon (CFCs)	1,430

EPA annually releases transportation related GHG emissions in millions of metric tons (MMT). Table 2-17 presents emissions in the U.S. from 2009 through 2013 (EPA 2015). These values are calculated in terms of GWP of each pollutant.

Table 2-17. GHG Emissions by Vehicle Type

Vehicle Type	GHG	Emissions in CO ₂ Equivalent Values (MMT)				
		2009	2010	2011	2012	2013
<i>Passenger Vehicle</i>	CO ₂	748.0	742.0	736.9	735.6	735.5
	CH ₄	1.2	1.2	1.2	1.1	1.1
	N ₂ O	13.8	12.9	12.3	10.7	9.4
	CFC	29.9	27.5	23.9	20.6	17.3
	Total	792.9	783.6	773.4	768.0	763.3
<i>Truck</i>	CO ₂	375.1	388.4	386.8	386.8	393.2
	CH ₄	0.1	0.1	0.1	0.1	0.1
	N ₂ O	1.2	1.2	1.1	1.1	1.1
	CFC	13.2	13.2	13.3	13.3	13.3
	Total	389.6	403.0	401.3	401.4	407.7

Total annual miles travelled by passenger vehicles and trucks are required to calculate the emission rates in terms of lbs/mile. As an example, 2013 data for passenger vehicles and trucks is 2,074,458 million miles and 106,582 million miles, respectively (FHWA 2013a). The primary reason for including Highway Statistics provided by FHWA for 2013 are (i) to be compatible with the most recent data given in Table 2-17 and (ii) to have the most recent data at the time this report is developed.

The unit cost of CO₂ is needed for calculating the climate change cost. As per 2015 data, the average unit cost of CO₂ is \$0.018665/lb (EPA 2016).

2.2.4 Business Revenue Change

Bridge construction projects can potentially impact customers' access to businesses, which will result in an increase or decline in business revenue (De Solminac and Harrison 1993). Even though decline in business revenue is temporary, the negative impacts are a major concern because they can create long term effects for some businesses (Wolffing et al. 2004). At present, there is limited literature on quantification of business revenue change. Wolffing et al. (2004) and Schieck and Young (2005) conducted research evaluating economic impacts on surrounding businesses during and after highway rehabilitation projects in Wyoming. A number of Wyoming cities were

analyzed in a case study. The economic impact was calculated from tax revenue data and data collected through surveys. It was reported that the survey results are likely to be more pessimistic during construction than the findings from actual tax data analysis. Schieck and Young (2005) and Wolffing et al. (2004) observed an increase in revenue for some businesses while others showed a shortfall in revenue. In a limited number of cities, during construction there was a small increase (~3%) in overall business revenue while a majority of the cities showed a decrease (~10%).

Handy et al. (2000), Kockelman et al. (2000), and Mills and Fricker (2011) evaluated business revenue change during bypass construction projects using econometric models such as panel data analysis, mixed effects models, and spatial econometric models. The application of these models, to achieve statistical accuracy, requires local sales data for an adequate number of locations and for an extended duration in order to generate a large sample. Traffic data plays a significant role when using these econometric models. Findings from the studies show 31% to 11% business revenue loss in a city with a population of around 5,000. Whereas, in cities with a population of around 13,000, the business revenue loss was as high as 63%, while the gain was about 1%.

Gangavarapu et al. (2004), Matthews et al. (2014), and Islam et al. (2014) compared economic impact for the open cut method versus trenchless techniques to justify implementation of trenchless technology, which has a higher initial cost. The findings of the study were inconclusive.

Konduri et al. (2013); Forkenbrock and Weisbrod (2001); Allouche and Gilchrist (2004); and CALTRANS (2011) show that evaluating business revenue change during bridge construction requires defining a commercial area influenced by the project. This area is described by the term “influence area”. WisDOT (2014) reports that the influence area can be established by either utilizing traffic demand models or with an analysis of a road network. The process depends on the complexity of the traffic network.

2.2.5 Data Collection Tools for Economic Impact Analysis

Use of site specific data is important to accurately evaluate economic impact on surrounding businesses and communities. Even though there are different methodologies for site specific data collection, community surveys are a feasible and powerful technique. OQI (2010) and Peters (2016) suggest the following steps to conduct an effective survey:

- Step 1. Design the survey process after defining the goals, target population, timeline, and the survey methods.
- Step 2. Develop questions and make sure that they are valid, easy to understand, and will yield reliable responses.
- Step 3. Train the survey (Note: Developing a survey is an iterative process. This requires reviewing, testing, and revising survey questionnaire to yield reliable results).
- Step 4. Execute the survey and collect data.
- Step 5. Analyze data and generate conclusions.

According to Kelley et al. (2003), the primary objective of conducting a survey is to collect data on a certain site or a problem, as well as to inform the participants - the users. The informational purpose of a survey can be achieved through informative paragraphs or questions which create awareness. A survey can have either or both of these objectives. In that case, the survey goals are determined and the questions are designed such that the answers fall into four main categories: i) nominal - indicating specific names or colors, ii) ordinal - indicating categories of importance, iii) interval - giving ordered values, and iv) ratio - requiring precise measurement to help data analysis and interpretation of results.

2.3 BRIDGE SLIDE ACTIVITIES

SIBC is an ABC method, where the replacement superstructure is constructed adjacent to an existing bridge on a temporary structure and moved in place with a sliding and an actuating system. Traffic is maintained on the existing bridge during the construction of the replacement superstructure parallel to the in-service bridge. After completion of the replacement superstructure, traffic is shifted and maintained on the replacement superstructure on the temporary alignment while preparing the site for the new bridge. Then, the road is closed for a short duration (1-3 days) while the new superstructure is slid into final alignment by a procedure called lateral bridge slide. A typical view of a replacement superstructure and a permanent substructure prior to bridge slide is shown in Figure 2-2.

Bridge slide operation requires additional activities compared to conventional construction. The additional activities include a temporary structure designed and constructed to support the superstructure during construction and slide, a sliding system to provide interaction surfaces and

a path for slide, and an actuating system to provide forces for initiating and maintaining bridge slide. In this section, components and design parameters of these activities are introduced. SIBC projects listed in FHWA repository and highway agency databases are the general source of this information.

The directional terminology presented in Figure 2-2 is used throughout the report for consistency. Accordingly, the direction parallel to sliding is defined as the sliding direction, direction perpendicular to sliding as the transverse direction, and gravity direction is the vertical direction.

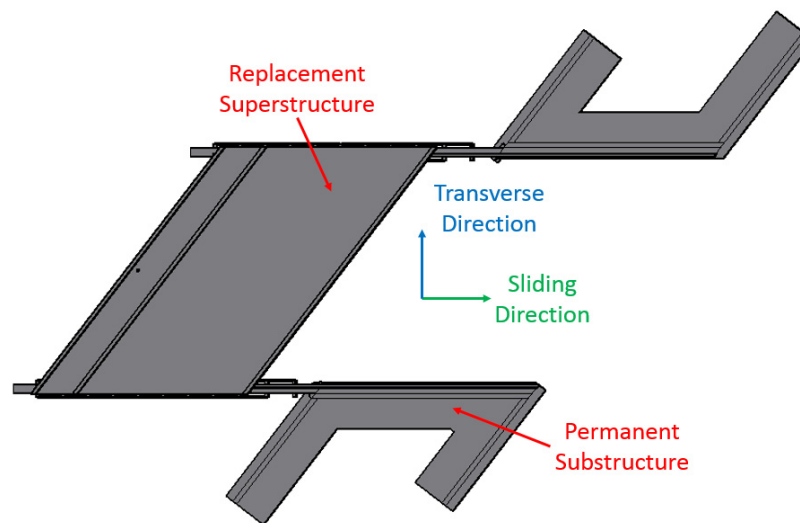


Figure 2-2. A typical view prior to slide

2.3.1 Sliding System

A bridge sliding system, in most cases, consists of *Teflon* pads or rollers and an actuating system. *Teflon* pads or rollers are the primary components of a slide mechanism. Additional components are integrated into a slide mechanism to control transverse and vertical movement of the superstructure. Slide mechanisms with *Teflon* pads and rollers are discussed in Section 2.3.1.1 and 2.3.1.2, respectively. An actuating system is incorporated into a sliding system to provide forces for initiating and maintaining the bridge slide. Actuating system components and design considerations are discussed in Section 2.3.2.

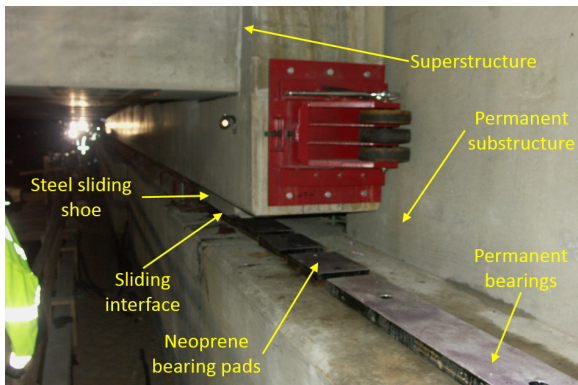
2.3.1.1 Sliding Mechanisms with *Teflon* Pads

When *Teflon* pads are used, the bridge superstructure is supported by stainless steel sliding shoes. The sliding shoes become an integral part of the bridge superstructure after the bridge is slid into

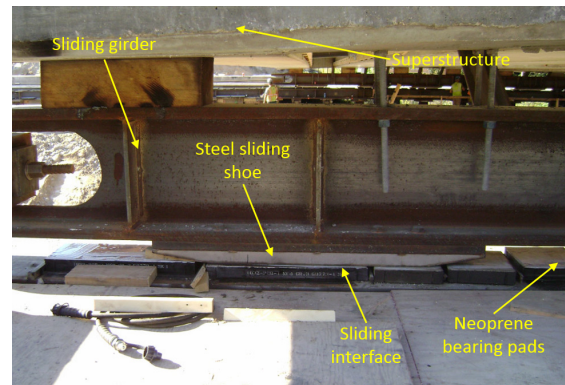
position and placed on permanent bearings (Figure 2-3a). Another approach is to use sliding girders. In that case, stainless steel shoes are attached to the bottom flange of the sliding girders while a bridge superstructure is supported on wooden blocks placed on the sliding girders (Figure 2-3b). After the bridge superstructure is slid onto the final horizontal alignment, superstructure is lifted with vertical jacks and placed on permanent bearings following the removal of sliding girders (Figure 2-4).

When the superstructure is slid directly onto the permanent bearings, a temporary substructure is constructed in-line with the permanent substructure (Figure 2-5a). When sliding girders are used, a temporary substructure with railing girders is constructed in front of the permanent substructure (Figure 2-5b).

Neoprene bearing pads with *Teflon* layers are placed on the permanent substructure or railing girders as shown in Figure 2-3. The interface between the polished stainless steel shoes and *Teflon* forms the sliding surface.

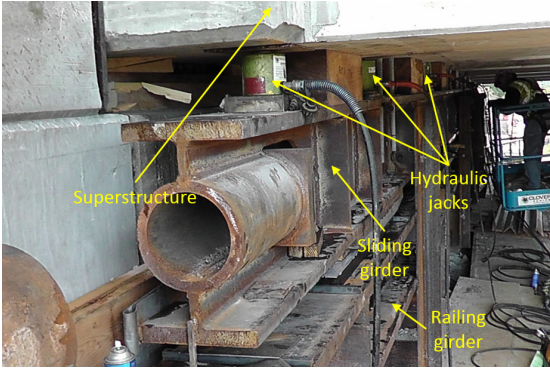


(a) Bridge sliding onto permanent bearings (sliding shoes are integrated into bridge superstructure)

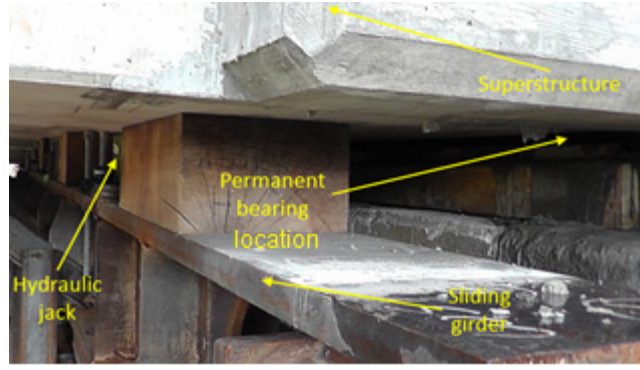


(b) Bridge sliding on railing girders (sliding shoes are part of the sliding girder)

Figure 2-3. Bridge sliding (a) onto permanent bearings and (b) on railing girders

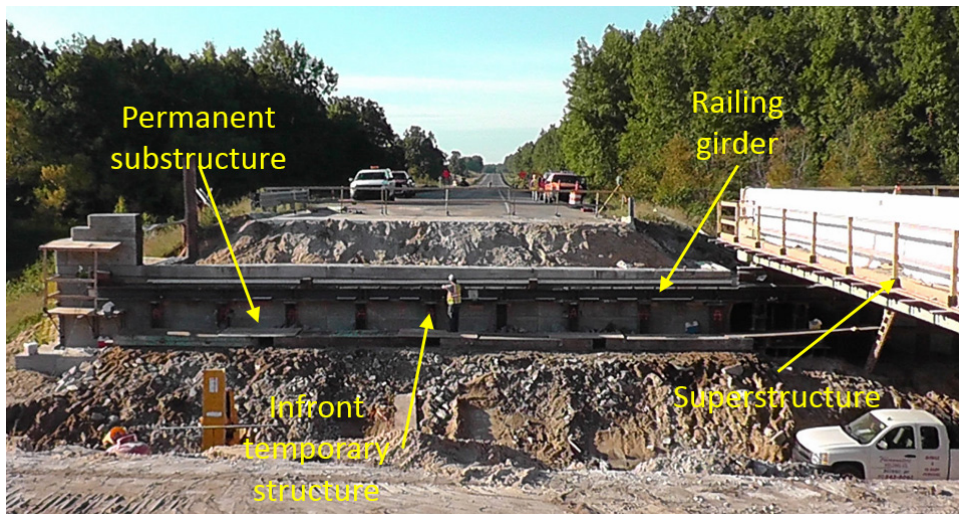


(a) Hydraulic jacks for vertical jacking

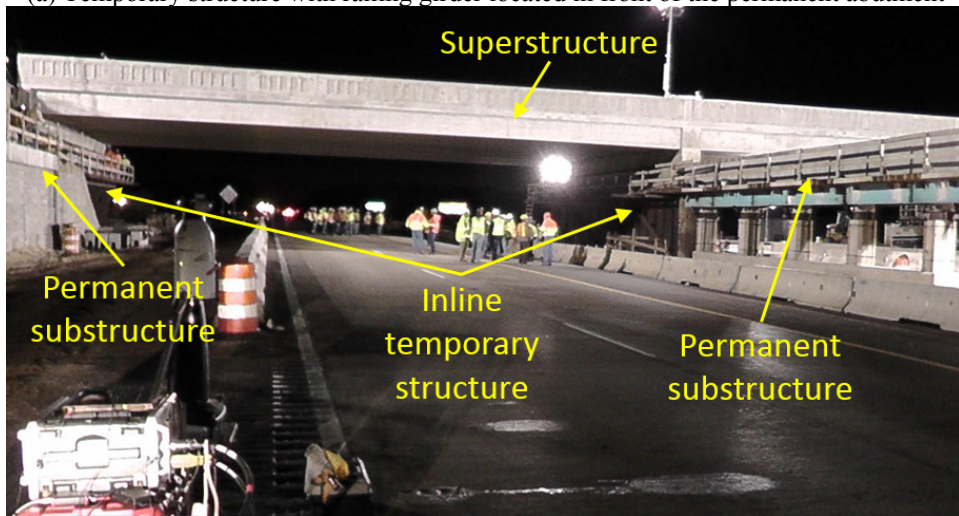


(b) Hydraulic jacks and permanent bearing locations prior to vertical jacking

Figure 2-4. Vertical lifting arrangement



(a) Temporary structure with railing girder located in front of the permanent abutment

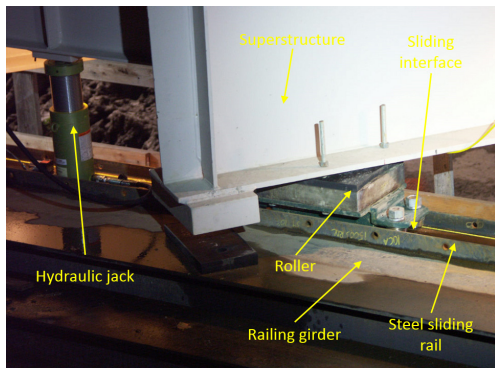


(b) Temporary structure constructed in-line with the permanent substructure

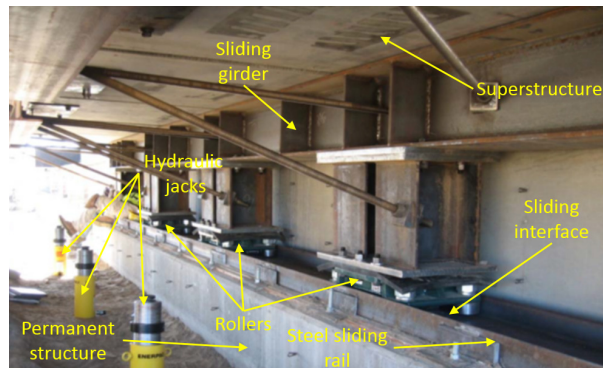
Figure 2-5. Temporary structure and permanent substructure positions

2.3.1.2 Sliding Mechanisms with Rollers

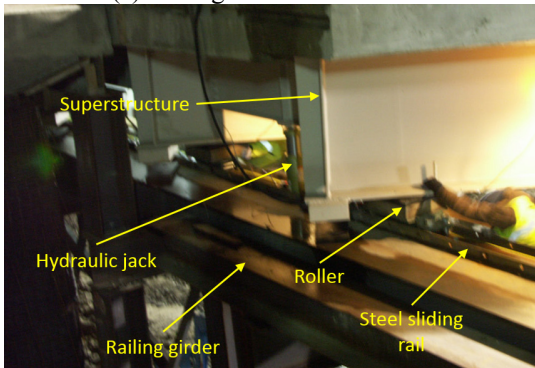
Rollers can be placed directly underneath bridge girders or sliding girders as shown in Figure 2-6a and b. Steel sliding rails are placed on railing girders or on a permanent substructure as shown in Figure 2-6b. Rollers are placed prior to slide by jacking the superstructure up (Figure 2-6c). The interface between the steel sliding rails and the rollers forms the sliding surface (Figure 2-6a and b). With this arrangement, the bridge is slid to final horizontal alignment, the superstructure is lifted using hydraulic jacks, and the rollers are removed. As the final step, the superstructure is lowered onto the permanent bearings (Figure 2-6d and e).



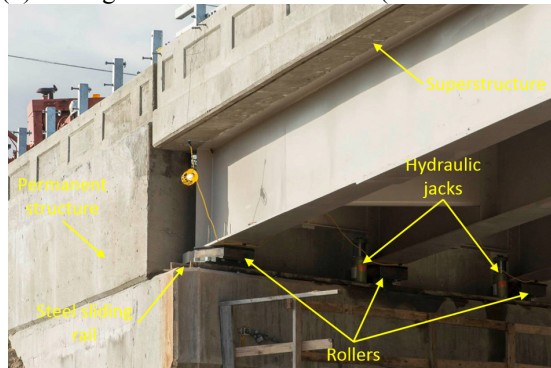
(a) Sliding mechanism with rollers



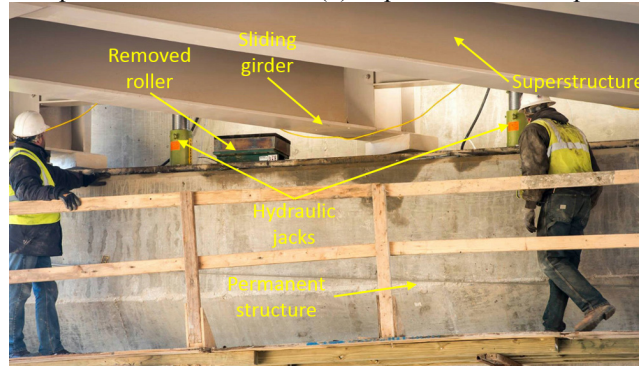
(b) Sliding mechanism with rollers (Dobmeier 2014)



(c) Roller placement prior to slide



(d) Superstructure final position prior to roller removal

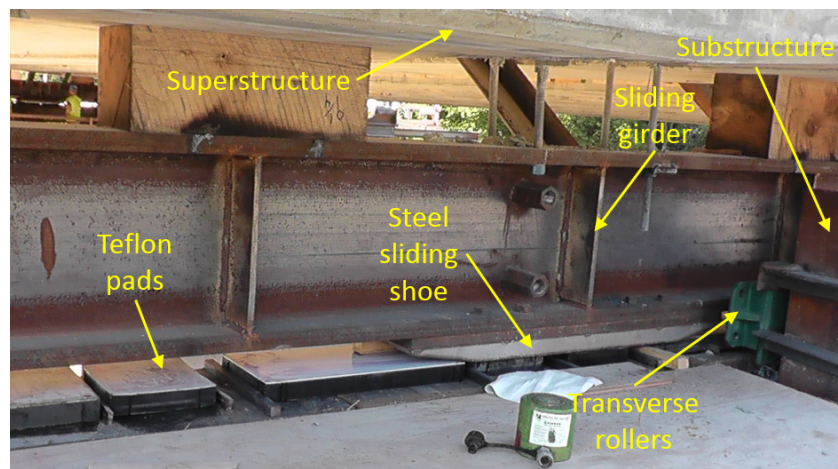


(e) Superstructure on a permanent bearing after roller removal

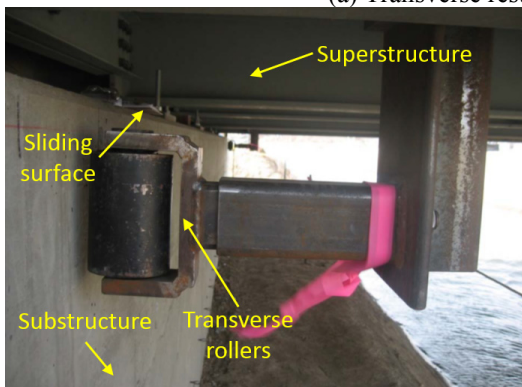
Figure 2-6. Sliding mechanism with rollers, components, and orientation

2.3.1.3 Transverse Movement Restraints

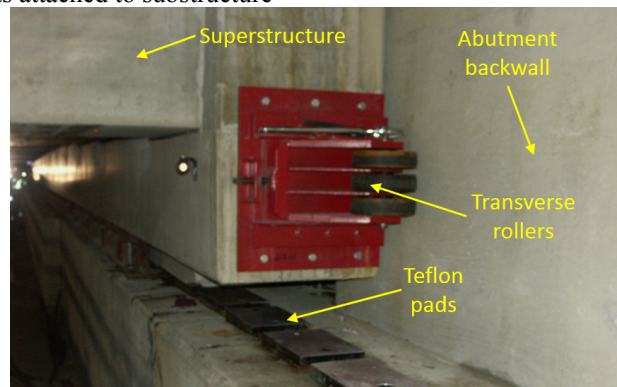
Superstructure alignment in the transverse direction is controlled with restraining rollers when Teflon pads are used (Figure 2-7). The rollers are either attached to the substructure or superstructure. Rollers bear against the side face of the backwall or sliding girder when attached to the substructure (Figure 2-7a). When rollers are attached to the superstructure, the vertical surface of the backwall or abutment wall provides the necessary restraint (Figure 2-7b and c). In both cases, tolerances up to 3 in. are provided between the interfaces for movement in the transverse direction to prevent jamming and to have the ability to steer the superstructure back to the slide direction.



(a) Transverse restraints attached to substructure



(b) Transverse restraint attached to superstructure (FHWA 2014b)

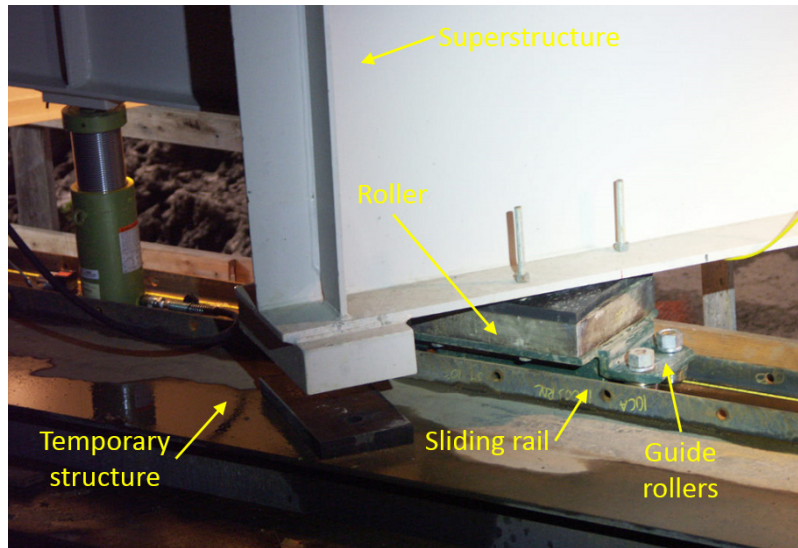


(c) Transverse restraint attached to superstructure (end diaphragm)

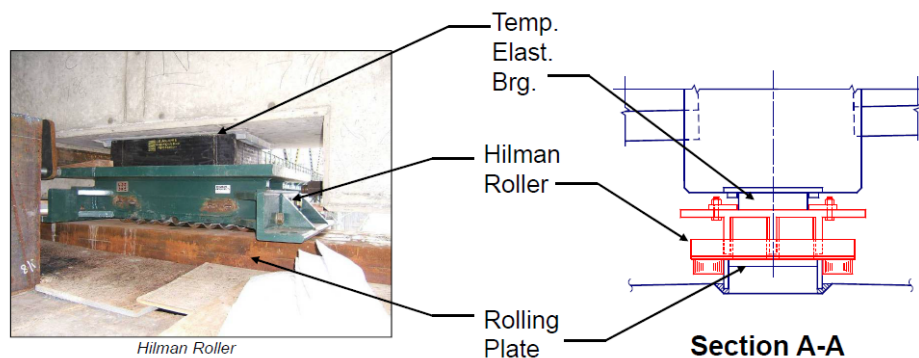
Figure 2-7. Transverse restraint with Teflon pads

Guide rollers are incorporated with the roller assembly placed under the fascia girders to control transverse movement (Figure 2-8a). The interface between the guide rollers and sliding rails provide transverse restraint. Guide rollers can be in contact with the inner or outer surface of the side walls of sliding rails (Figure 2-8b). Guide rollers and a sliding rail need to be specified in

conformity with rollers utilized and communication with the roller manufacturer. Tolerances between the guide rollers and sliding rails are often below 0.1 in. which provides a tight tolerance for transverse movements.



(a) Typical transverse restraint system with rollers



(b) Transverse rollers in contact with outer surface of sliding rail. (Merth 2008)

Figure 2-8. Transverse restraints with rollers

2.3.1.4 Sliding System Parameters and Design Considerations

The weight of the superstructure and all the components and attachments above the sliding surface (W) acts normal to the sliding surface. With the friction coefficient of the sliding surface, W controls the magnitude of the required sliding forces.

With neoprene pads with Teflon and stainless steel shoes, bearing pressure (σ_B) is calculated as the ratio between vertical load at each sliding shoe and the contact area of a shoe. A uniform pressure distribution can be assumed for design. The number of shoes and the size of each shoe need to be

determined based on the allowable pressure on the neoprene bearing pads. As per Aktan and Attanayake (2015), typical values of interface pressure range from 0.5 ksi to 2 ksi.

When designing a sliding system, static and kinetic friction need to be considered. Typical static friction values used in earlier projects ranges from 5% to 10% (Aktan and Attanayake 2015). Kinetic friction is a function of sliding velocity (v_s). The sliding velocity is not constant throughout the slide; however, a value needs to be defined to estimate kinetic friction coefficient. A sliding velocity of 6 in./min was documented during the US-131 over 3 Mile Road bridge slide (Aktan and Attanayake 2015). In addition to the sliding velocity, kinetic friction is also a function of normal stress at the sliding surface (σ_B), Teflon composition, temporary sliding shoe surface roughness, surface treatment (lubrication applied at the interface), temperature, and the angle between the surface polishing of steel and the *Teflon* (Hwang et al. 1990). Even though a large number of parameters affect the kinetic friction coefficient, at least the bearing pressure and sliding velocity needs to be considered in order to estimate a value. Kinetic friction estimates in earlier projects ranges from 3% to 5% (Aktan and Attanayake 2015). Test slides can be performed to verify the design friction coefficient estimates.

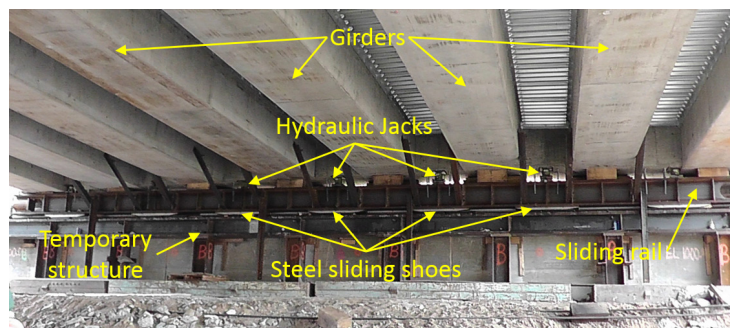
Sliding force (S_F) is the sum of all frictional forces developed at the sliding surface. It is a function of weight and coefficient of friction. Since kinetic friction is a function of bearing pressure and velocity, sliding force is also a function of those parameters.

Sliding bearings are designed considering horizontal forces (sliding forces) and vertical stress (bearing pressure). Bearing deformation should be minimized. Deformations may result in a change in contact area which will affect bearing pressure, coefficient of friction, and consequently the sliding forces. In order to accommodate the surface irregularities of the sliding girder, steel reinforced neoprene pads with Teflon should be used instead of a single Teflon layer. Dimpled Teflon is preferred in order to retain the lubricant directly under the pad and on the sliding surface.

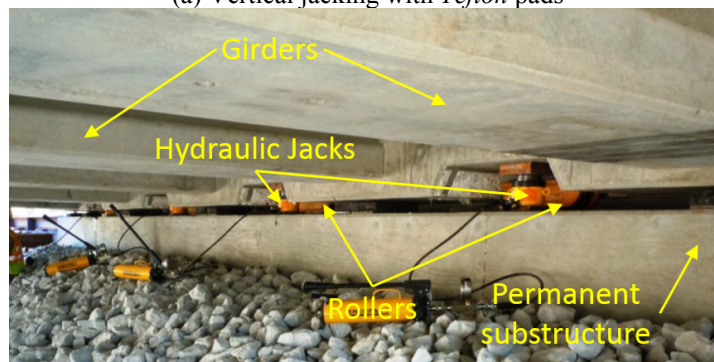
Manufacturer data sheets can be used to make the roller selection. Manufacturers provide maximum capacity for their products. Based on the load capacity and the contact area, the maximum roller pressure (σ_R) can be calculated. Sliding girder (rail) bearing capacity needs to be checked against the roller pressure. Hence, roller selection primarily depends on the rail surface allowable bearing capacity. This allows specifying the appropriate number of rollers to distribute

the structure weight. The friction coefficient (μ) of typically used rollers for bridge slides is less than 5% (Hillman *n.d.*). Static and kinetic friction coefficients are the same for rollers.

Vertical jacking is required when sliding involves rollers or temporary *Teflon* pads. The number of jacking locations and the capacity of jacks are required. Generally, jacks are placed between each girder (Figure 2-9). Non-uniform load distribution due to deck overhang and safety barriers needs to be taken in to consideration. The superstructure needs to be analyzed under jacking loads to check the maximum stresses developed at the deck surface. Also, bearing stresses and the use of stiffeners at support locations should be evaluated.



(a) Vertical jacking with *Teflon* pads



(b) Vertical jacking with rollers

Figure 2-9. Vertical jacking configuration

Transverse movement tolerance (t_r) defines allowable movement in a transverse direction. Tolerances are defined based on a specified sliding system and the project requirements. Typical tolerances are described in Section 2.3.1.3. Movement in a transverse direction at the level defined by the tolerances will develop transverse forces (RF) between transverse restraints and guides.

2.3.2 Actuating System

A hydraulic operation system and hydraulic actuators are included in an actuating system to generate and deliver the required forces to initiate and maintain a slide. Hydraulic operation

systems include a reservoir, pump, and a hydraulic pressure control unit (Figure 2-10). Hydraulic cylinders and prestressing jacks are two available actuators utilized in many completed SIBC projects. Each actuator includes specific components and considerations to provide forces to initiate and maintain slide as well as to monitor movements.

Hydraulic fluid stored in the reservoir is pumped into the actuator during extension stroke and drained during a retraction. Pressure is monitored through a power control unit to control the displacement of the stroke. Pressure regulated control and servo controlled units are available as pressure control systems. Pressure regulated units are capable of controlling hydraulic pressure manually, whereas servo controlled systems monitor displacements through sensors and calibrate applied pressure automatically to adjust the movement. Servo controlled systems can be used to maintain the bridge superstructure alignment because equal stroke is maintained between actuators by synchronizing measured displacements through the adjustment of actuating forces. A servo controlled system was used for the Dundas Street Bridge slide, and a differential transverse displacement of less than 0.2 in. was maintained (Anderson and Trankler 1991). Meanwhile, the West Mesquite Interchange Bridge slide operation took three hours more than planned because maintaining alignment with a pressure regulated system made it difficult to adjust the misalignment between the rails (Searcy et al. 2012).

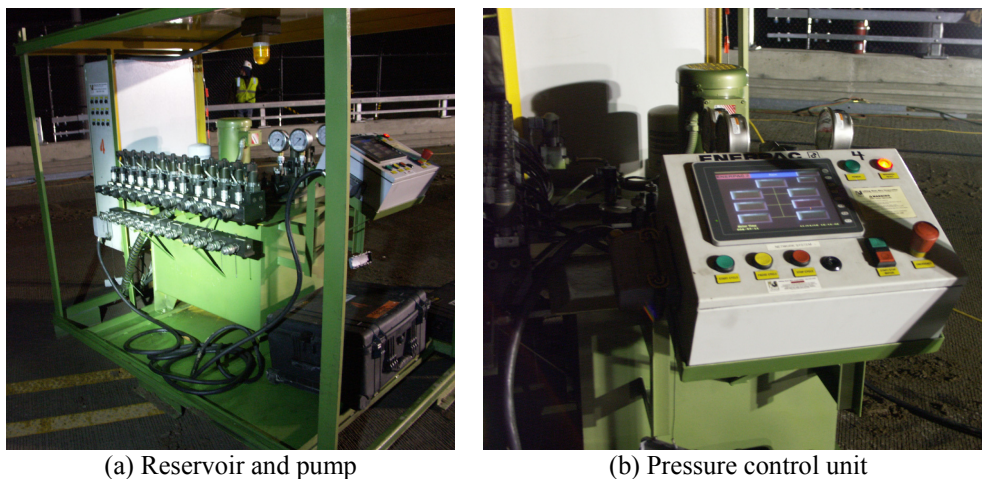


Figure 2-10. Hydraulic system

Hydraulic cylinders are utilized as actuators during several SIBC projects. They are primarily used for pushing the superstructure (Figure 2-12a). Hydraulic cylinders with pushing and pulling capabilities are also available (Figure 2-12b). Such hydraulic cylinders are very useful when the sliding structure needs to be retracted due to jamming or other reasons.



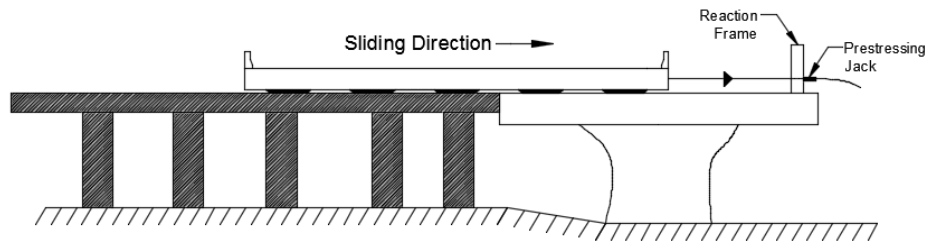
(a) Hydraulic cylinder with only pushing capabilities (Lesch 2015)



(b) Hydraulic cylinder with pulling and pushing capabilities

Figure 2-11. Hydraulic cylinders utilized in completed SIBC projects

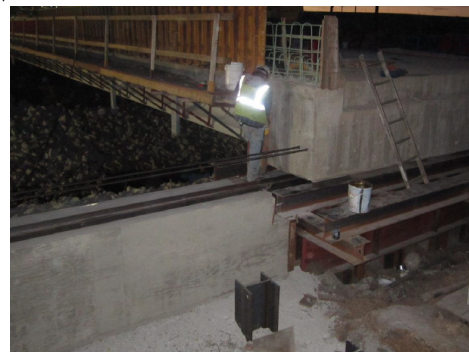
Hydraulic prestressing jacks are the other alternative utilized in SIBC. A rod is connected to a superstructure and extended through the jack that is mounted against a stationary reaction frame as shown in Figure 2-12. As the jack pulls the cable, the superstructure is moved towards the reaction frame. The sliding operation is discrete, and the distance moved during each discrete event depends on the stroke length limitation of the jack.



(a) Overview



(b) Prestressing jack mounted against a reaction frame (Hawash and Nelson 2014)



(c) Cable and superstructure connection

Figure 2-12. Use of a prestressing jack for pulling a bridge

A prestressing jack can be mounted against the sliding superstructure with one of the pulling rods connected to a reaction frame as shown in Figure 2-13. This configuration allows pushing of the

structure to the final alignment. This operation also consists of several discrete events, and the pushing distance during each event depends on the available stroke length of the jack.

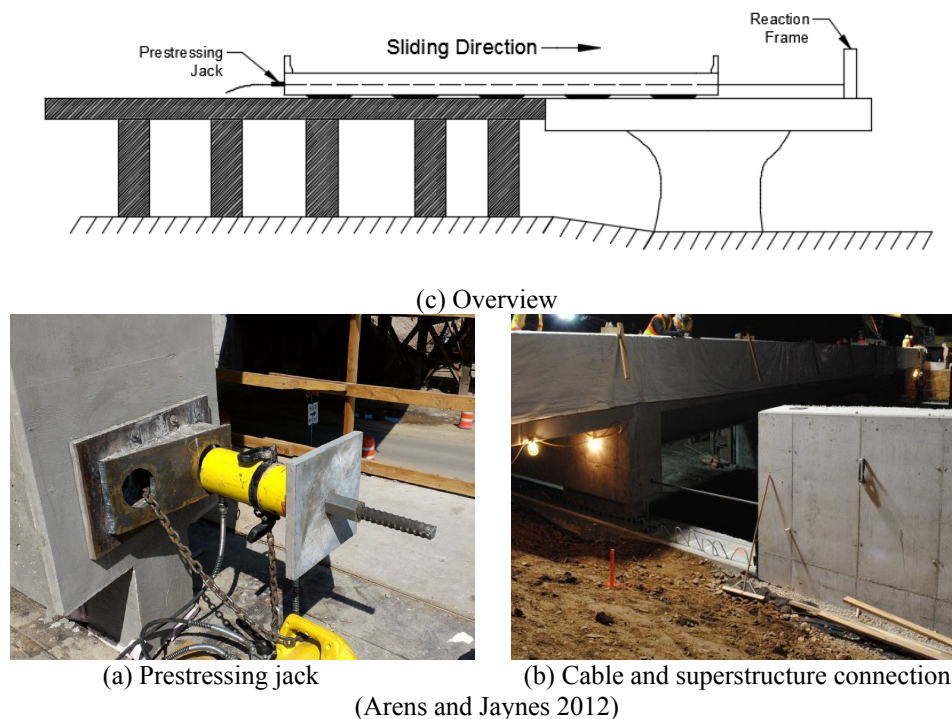


Figure 2-13. Prestressing jack with pushing method

2.3.2.1 Design Considerations and Parameters

The following is a list of parameters that needs to be considered during the selection of an actuating system and the design of a sliding operation:

- Actuating force (A_F): this is the total force applied by an actuator to the superstructure. It is estimated by summing the inertia force developed in the system (i.e., acceleration times mass) to sliding forces. An actuating force that is slightly greater than the sliding force is adequate to maintain a slide because sliding can be initiated and maintained with low acceleration. The difference between an actuating force and a sliding force is defined as the net force (N_F).
- Actuator capacity (C): this is the maximum force capacity. It should be larger than the estimated actuating forces in order to compensate for a possible increase in sliding forces. Capacities of actuators used in completed projects range from 30 to 110T.
- Actuator stroke length (S_L) defines the maximum length that a structure is pushed or pulled during each discrete slide event. Stroke length of actuators used in already implemented projects ranges from 2 in. to 48 in.

- Actuator jerk (j): this is the rate of change of the acceleration and deceleration of the actuator (ramp up and ramp down durations). Sudden increases in acceleration result in greater reaction forces than sliding forces because of the dynamic response of the temporary structure.
- Reservoir volume and pump capacity of the hydraulic operation system should be sufficient to provide required sliding velocities and actuating forces.
- The connection between the hydraulic cylinder piston and the sliding rail requires detailed design consideration. Connection points should be provided with tolerances to provide flexibility in attaching the cylinder to the sliding rail. In addition, swivel connection is most appropriate between the cylinder piston and the superstructure. Load transfer to the superstructure is prevented with a swivel connection, except in the sliding direction.
- Prestressing jacks require a stationary reaction frame. A temporary structure can include the reaction frame, or part of the permanent substructure can be utilized as a reaction frame for the prestressing jacks.

2.4 BRIDGE SLIDE MONITORING TECHNOLOGY

Design parameters for sliding and actuating systems are explained in Section 2.3. The coefficient of friction is an important design parameter. Difference in friction coefficient at each sliding surface results in the development of unequal sliding forces between rails. The difference in sliding forces results in a transverse movement of the bridge and the twisting of the bridge superstructure about the vertical axis (defined as ‘yaw’ or ‘racking’). As a result of yaw, transverse forces are developed when the sliding structure engages with transverse restraints. At present, transverse forces are not generally considered in the design of temporary and permanent structural components, as well as the components used to form a sliding mechanism. This is primarily due to the lack of knowledge of the forces that develop during bridge slides. Hence, quantification of such forces through field monitoring is needed to standardize bridge slide designs and operations.

The *Slide-In Bridge Construction Implementation Guide* published by the Federal Highway Administration (FHWA 2013b) recommends including a monitoring plan that entails special provisions to control the horizontal and vertical alignment of a bridge superstructure during a bridge slide. The guide includes special provisions from the Massena Bridge and Wanship Bridge projects as examples. The monitoring tasks described include measuring elevations and determining deflection at the span ends relative to mid span while the span is being lifted.

Monitoring superstructure rotation about longitudinal and transverse axes is done by measuring elevation or other methods approved by the engineer. Monitoring and reporting excessive deflections, twist, and changes in longitudinal and transverse gradients is also requested.

ABC Standard Concepts: The Lateral Slide Addendum Report (SHRP2 2015) suggests including a monitoring plan regardless of the structural system selected for construction. A monitoring plan has significant value when a superstructure is slid in place without transverse restraints because there is a great potential for misalignment. The report suggests using displacement control actuating systems that utilize synchronized self-monitoring systems to control a superstructure move and maintain a move at the same rate. This allows for reducing possible racking or binding of a superstructure.

Each SIBC project includes a monitoring plan. Monitoring plans often indicate documenting hydraulic manifold pressure, and displacements in the direction of slide and transverse to slide. Displacements can be monitored manually, often using tapes, total stations, or servo controlled monitoring systems. Hydraulic manifold pressure is measured by using pressure gauges, load cells attached to actuators, or computerized servo controlled monitoring systems.

The US-131 over 3 Mile Road bridge slide in Michigan utilized a displacement and hydraulic pressure monitoring plan. The sliding distance was monitored by measuring tapes against an alignment rod mounted at each end of the sliding girder as shown in Figure 2-14a. The rod was also used as a reference to measure sliding girder offset from the sliding alignment. In addition, railing girder and deck displacements were continuously monitored with two total stations using 9 targets on the deck and 7 targets on each railing girder (Figure 2-14c, d). During the pulling operation, the hydraulic pressure to both jacks was kept equal and adjusted manually as needed (Figure 2-14c) (Aktan and Attanayake 2015). Methods similar to those shown in Figure 2-14a have been used in a large number of projects. During the slide of the I-80 Bridge in Wanship, Utah, the alignment was tracked along the abutment using a monitoring rod as well as by measuring the gap between the sleeper and approach slabs (Arens and Jaynes 2012). During the slide of Massena Bridge, actuator pressure and the displacement at both ends of the bridge were monitored (Hawash and Nelson 2014). The I-44 over Gasconade bridge slide utilized 70 ton

actuators which were synchronized to control the differential displacement at each bent location (FHWA 2014c).

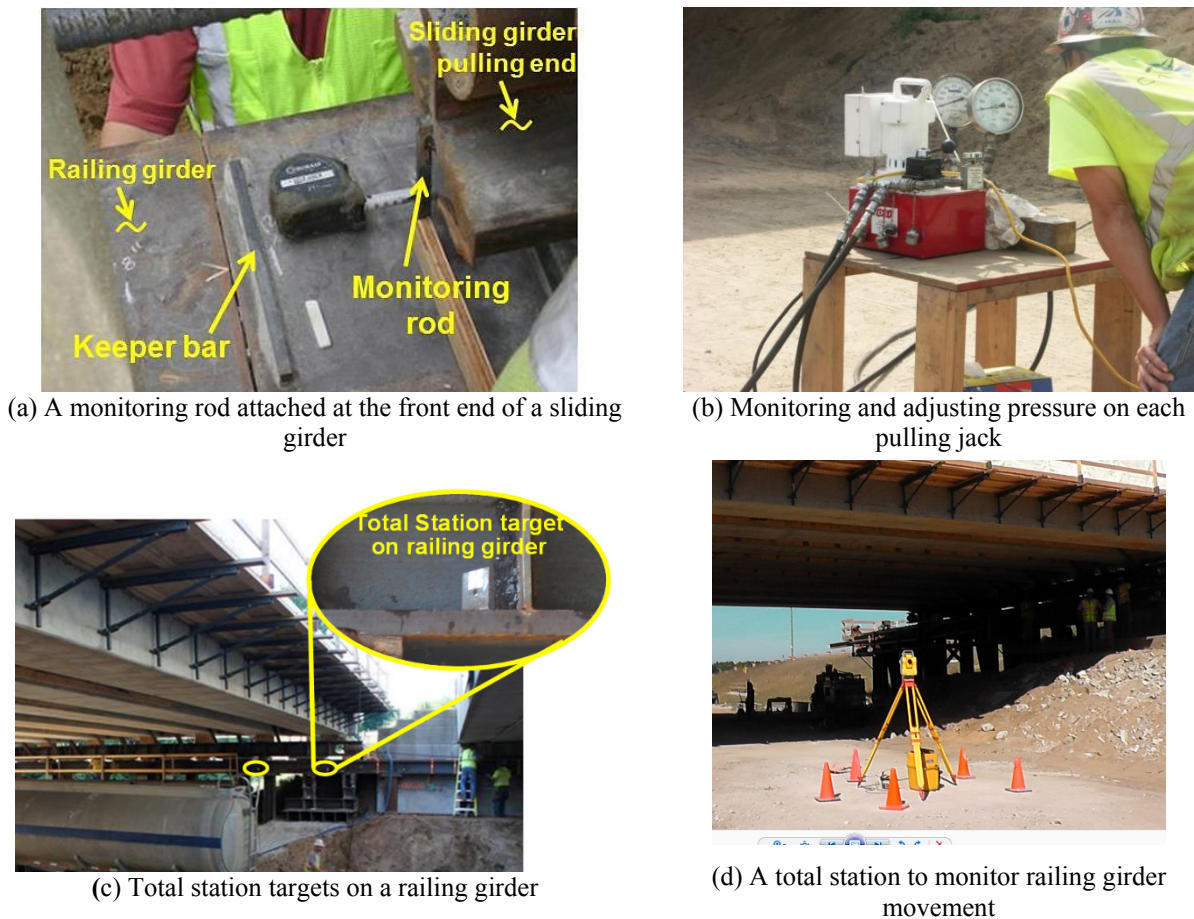


Figure 2-14. Monitoring of US-131 over 3 Mile Road bridge slide

Pier displacements were monitored during the M-50 Road over I-96 bridge slide in Michigan. This project included sliding a two span continuous for live load superstructure. The bridge pier was constructed on a shallow foundation. During this bridge slide, the pier was instrumented with laser targets, and the movement was recorded using a *Laser Tracker*, a non-contact displacement measurement equipment (Figure 2-15). The *Laser Tracker* was placed with a view of all targets from about 150 ft away so that the monitoring crew and equipment is away from the active construction zone. Later, the measured displacements were analyzed and the forces developed in the system during the bridge slide were calculated (Aktan and Attanayake 2015).



(a) Reflector locations - metal plates to attach magnetic bases with reflectors
 (b) Laser Tracker, controller, and the computer at the site

Figure 2-15. Instrumentation of M-50 Road over I-96 bridge slide

Servo controlled hydraulic cylinders and associated monitoring systems were utilized during several bridge slide projects. The superstructure of the Capilano Bridge in Vancouver, Canada, was pulled using strand jacks connected to a computerized, displacement monitoring control system (Johnson 2012). The sliding operation of the Dundas Street Bridge in Ontario was performed using a centralized computer control system with video cameras, video monitors, pressure gauges, and digital readout devices. Data was collected from displacement sensors installed on each substructure. The data was acquired in 0.08 in. (2mm) increments. A visual backup was provided by video cameras mounted on the bridge at each substructure. The data received from displacement sensors was monitored simultaneously with images collected from video cameras. Displacement data was synchronized with applied pressure, and pumps were set to shut off when a predefined maximum pressure was reached. The servo control limited the differential movement between rails to prevent possibly developing damaging forces as a result of jamming during the slide (Anderson and Trankler 1991).

Another successful and large scale bridge slide project, the Milton Madison Bridge between Kentucky and Indiana, also utilized a servo controlled system for vertical jacking and lateral bridge slide operations. Inclinerometers with wireless transmission capability were used to monitor horizontal alignment of truss sections during lifting. Laser distance sensors synchronized with jack pressure recorded the displacement of the superstructure at each of the five piers (V.S.L Heavy Lifting® n.d.)

The primary purpose of monitoring technologies implemented during bridge slides is to assure the avoidance of problems preventing a successful completion of the project. Except in two cases, the

monitoring data from past projects has not been documented or published. This could have been due to lack of interest or the proprietary nature of the technology and data sources. However, the lack of documentation limits the opportunity to understand structural response and the forces developed in the system. Even though there may not be an incentive for the contractor to publish the data collected from the equipment and sensors, there is a compelling need to collect structural response data in order to calculate forces developed during the slide in, which can then be used to standardize the design and construction of bridge slide activities. This requires mounting a separate set of sensors. However, bridge site access is limited for such activities due to very strict schedules that the contractors have to follow in order to complete bridge slides and other activities and open the bridge for traffic. Hence, there is a need for developing instrumentation and set ups that can be mounted on the structure with minimum interference to the construction crew and a process to quantify the forces developed in the system.

3 THE MICHIGAN ACCELERATED BRIDGE CONSTRUCTION DECISION-SUPPORT (Mi-ABCD) TOOL

3.1 OVERVIEW

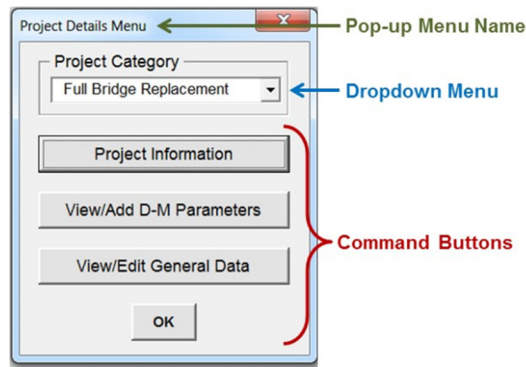
Aktan and Attanayake (2013) developed a multi-criteria decision-support framework to comparatively assess CC vs. ABC. The framework was customized for implementation in Michigan and supplemented with a guided software program titled *Michigan Accelerated Bridge Construction Decision-support* (Mi-ABCD) tool. The software was developed using Microsoft Excel and Visual Basic for Applications (VBA) scripts. In the 2013 version of Mi-ABCD, the ABC only encompassed PBES construction.

Recent ABC technologies, such as SPMT and SIBC, are being increasingly implemented throughout the U.S. In Michigan, SIBC was implemented in three pilot projects involving four bridge replacements. Aktan et al. (2014) and Aktan and Attanayake (2015) present details of two projects, US-131 over 3-Mile Road and M-50 over I-96. Chapter 5 of this report presents details of the other project, M-100 over the Canadian National (CN) railroad. To address the need of assessing four bridge construction/replacement methods (CC, PBES, SPMT, and SIBC) for a site, the decision-support framework developed by Aktan and Attanayake (2013) was extended. Aktan and Attanayake (2015) presented the updated scoping framework and the associated guidelines for its implementation. This chapter presents an overview of the software. A user manual is developed for the software and is included as a supplemental document to this report.

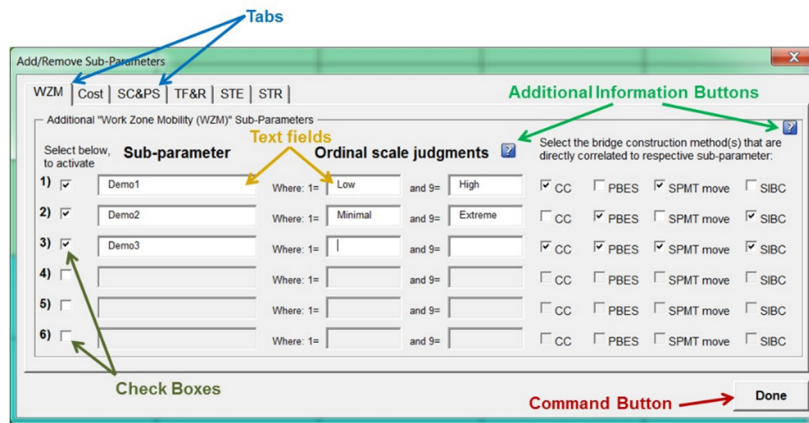
3.2 THE MI-ABCD PROCESS

3.2.1 Sample Popup Menus and Datasheet

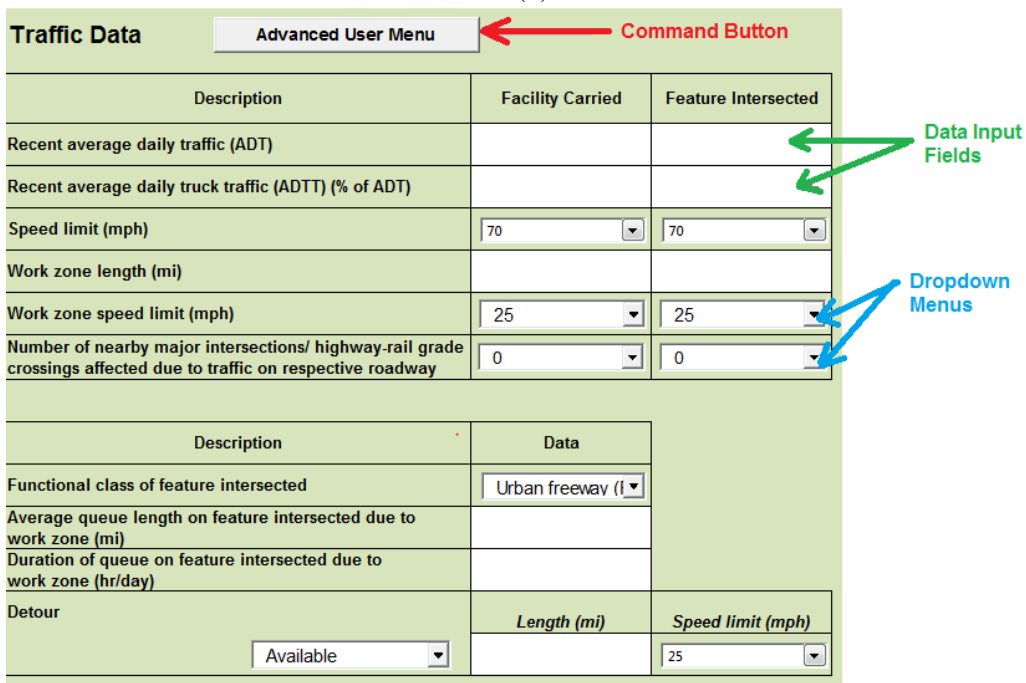
The VBA's Graphical User Interface (GUI) forms are utilized to interact with the user. These forms are termed as *pop-up menus* (Figure 3-1-a and b), and the Excel sheets that are customized for user input are termed as *datasheets* (Figure 3-1-c). The main features of a *pop-up menu* are to provide (1) command buttons, (2) dropdown menus, (3) tabs, (4) text fields, (5) check boxes, and (6) an additional information button (??) (Figure 3-1-a and b). The most commonly used features are the *command buttons* and *dropdown menus*. The primary features of a *datasheet* are (1) command buttons, (2) dropdown menus, and (3) data input fields (Figure 3-1-c).



(a)



(b)



(c)

Figure 3-1. Sample popup menus and datasheet

3.2.2 User Menus

The software allows data entry for two user types; *Advanced User* and *Basic User*. The *Advanced User* is generally envisioned to be the project manager who is familiar with the project specifics of site-specific data, cost estimates, traffic data, and construction methodologies. The *Advanced User* enters and/or edits *Project Details*, *Site-Specific Data*, *Traffic Data*, *Life-Cycle Cost Data*, and *Preference Ratings*. Finally, the *Advanced User* can execute data analysis and view *Results*. The *Advanced User Menu* (Figure 3-2a) includes the command buttons for entering and editing data, data analysis, and viewing results. In order to execute the process, the *Advanced User* must complete all the data entry steps before any *Basic User* can use the program.

The project specialists with construction experience are designated as *Basic Users*. This is because their task is limited to entering preference ratings for qualitative parameters based on their experience with recent bridge projects. The *Basic User* can view *Project Information*, enter *Preference Ratings*, execute analysis, and view *Results* (Figure 3-2b). One of the updated features in this software is that it allows the *Basic User* to include their reasoning in the comment boxes while assigning *Preference Ratings*. The subsequent users can view the comments from previous users, but not the ratings.

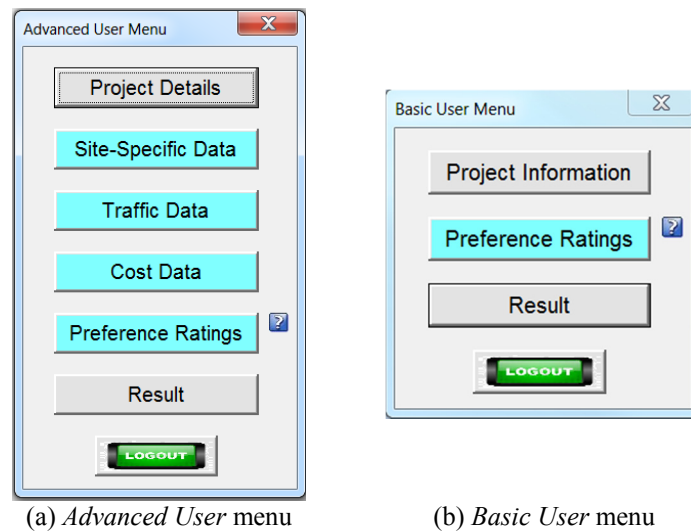


Figure 3-2. User menus

3.2.3 Implementation Process

First, the *Advanced User* needs to complete all the data entry in the *Advanced User Menu* before requesting any *Basic User* to provide *Preference Ratings*.

3.2.3.1 Data Entry Using the Advanced User Menu

Project Information: The first step for an *Advanced User* (AU) is to access the *Project Details Menu* and the *Project Information* datasheet to enter project information (Figure 3-3). The current version of the program allows for the selection of evaluation type at the beginning of data entry or after completing data entry. If an AU selects all four bridge construction/replacement methods at the beginning of the data entry process, the user has the ability to perform evaluations of limited alternatives after completing data entry. Otherwise, the options are limited.

Project Information	
Name:	M-50 over I-96
Date:	8/16/2016
By (advanced user):	WMU
Evaluation type:	CC vs. PBES vs. SPMT move vs. SIBC
Description:	CC vs. PBES vs. SPMT move vs. SIBC CC vs. PBES PBES vs. SPMT move vs. SIBC SPMT move vs. SIBC

Note: A reference image of the project site can be inserted above. To insert an image, double click on the above box to

Figure 3-3. *Project Information* datasheet

Decision-Making Parameters: Using the *Project Details Menu*, the AU can select *View/Add D-M Parameters*. Figure 3-4 shows the default table with major and sub-parameters. Some of the sub-parameters include secondary level sub-parameters (Aktan and Attanayake 2015). These secondary level sub-parameters can be accessed by clicking on the “S-L Sub” button on the decision-making parameter table shown in Figure 3-4. The AU is allowed to add sub-parameters to the table. However, this chapter does not present the process of adding a decision-making (D-M) parameter. Please refer to the user’s manual for such information.

Decision-Making Parameters for Full Bridge Replacement							Project Details Menu
Major-Parameters	Work Zone Mobility (WZM)	Cost	Seasonal Constraints and Project Schedule (SC&PS)	Technical Feasibility and Risk (TF&R)	Site Considerations (STE)	Structure Considerations (STR)	
Sub-Parameters and Secondary-Level Sub-Parameters (S-L Sub)	Significance of facility carried S-L Sub	Direct Cost S-L Sub	Stakeholders limitations	Risks S-L Sub	Site vicinity S-L Sub	Existing superstructure S-L Sub	
	Lane closure considerations S-L Sub	Indirect Cost S-L Sub	Seasonal limitations	Contractor experience S-L Sub	Staging area and travel path S-L Sub	Existing substructure/foundation S-L Sub	
	Detour considerations S-L Sub	Alternative Specific Cost S-L Sub	Construction duration		Feature intersected S-L Sub	Span S-L Sub	
	Significance of feature intersected traffic S-L Sub				Limitations for SIBC S-L Sub	Limitations for PBES construction	
					Site condition complexities	Geometric complexity for SPMT move	
					Scour or hydraulic complexities		
					Environmental protection near and within the site		
					Aesthetic requirements		
							Add Sub-Parameters

Figure 3-4. Decision-making parameters for highway over highway project

General Data: As the last step in the *Project Details* menu, the *General Data* (e.g., wage rate of drivers, vehicle operating cost, accident cost, accident rate, etc.) datasheet can be accessed and the user can review/edit the data incorporated into the program knowledgebase. The general data will not require frequent changes.

Site-Specific Data: As shown in Figure 3-2a, after completing project details data entry, the next command button allows access to the *Site-Specific Data* datasheet shown in Figure 3-5. The data required for this datasheet is obtained from the layout of the project site, data from the corridor planning process, and the preliminary design of the proposed bridge. Data entry to the datasheet is performed using dropdown menus and data input fields.

Traffic Data: As shown in Figure 3-2a, after completing site-specific data entry, the next command button allows access to the *Traffic Data* datasheet shown in Figure 3-6. Data from the corridor planning process and the preliminary traffic study at the site are required for completing the datasheet. Data entry is by dropdown menus and data input fields.

Cost Data: As shown in Figure 3-2a, after completing traffic data entry, the next command button allows access to the *Cost Data* datasheet (Figure 3-7). This datasheet is related to the bridge construction methods. The project manager(s) needs to identify the cost estimates for the respective bridge construction method prior to entering the data. Data entry to the datasheet is performed using data input fields.

Site-Specific Data	
Description	Data
County of the project	Alcona
Number of clustered bridge replacement projects	1
Allowable ground bearing pressure (k/ft ²)	Less than 2
Distance to staging area (or) travel path length for SPMT move (ft)	
Travel path slope	Less than 4%
Specialty equipment procuring distance to project site	249 mi or Less
Feature intersected type	Freeway or NHS arterial
Existing underclearance	14.25 ft or less
Vertical grade/slope of the existing superstructure	Less than 4%
Existing maximum span length (ft)	
New maximum span length (ft)	
Number of main spans	1
Length of new bridge (ft)	
Width of new bridge (ft)	
Superstructure type of new bridge	Steel girders system
Reuse potential of existing substructure with or without improvements	Cannot be reused
Number of major utilities that need relocation due to staging area and/or travel path	None
Level of difficulty for relocating the major utilities	N/A

Figure 3-5. *Site Specific Data* datasheet

Traffic Data

Description	Facility Carried	Feature Intersected
Recent average daily traffic (ADT)		
Recent average daily truck traffic (ADTT) (% of ADT)		
Speed limit (mph)	70	70
Work zone length (mi)		
Work zone speed limit (mph)	25	25
Number of nearby major intersections/ highway-rail grade crossings affected due to traffic on respective roadway	0	0

Description	Data				
Functional class of feature intersected	Urban freeway (f				
Average queue length on feature intersected due to work zone (mi)					
Duration of queue on feature intersected due to work zone (hr/day)					
Detour	<table border="1"> <thead> <tr> <th>Length (mi)</th> <th>Speed limit (mph)</th> </tr> </thead> <tbody> <tr> <td></td> <td>25</td> </tr> </tbody> </table>	Length (mi)	Speed limit (mph)		25
Length (mi)	Speed limit (mph)				
	25				

Description	Before Construction
Level-of-service (LOS) on facility carried	A
LOS on feature intersected	A
LOS on detour route	A
LOS on nearby major intersection-1 due to traffic on facility carried	N/A
LOS on nearby major intersection-2 due to traffic on facility carried	N/A
LOS on nearby major intersection-1 due to traffic on feature intersected	N/A
LOS on nearby major intersection-2 due to traffic on feature intersected	N/A

During Construction using PBES	During SPMT Move Activity	During Bridge Slide Activity
A	N/A, or Full Closure	N/A or Full Closure
A	A	A
A	A	A
N/A	N/A	N/A
N/A	N/A	N/A
N/A	N/A	N/A
N/A	N/A	N/A

Figure 3-6. Traffic Data datasheet

Cost Data			
Description	Data		
Maintenance of traffic (MOT) cost per day (\$) <i>Note: This cost is estimated based on the facility carried and/or feature intersected requirements to maintain traffic. It includes the cost of temporary traffic control devices, work zone intelligent transportation system devices, etc. that are included in the traffic management plan of the project.</i>	\$1		
Cost of upgrading detour (\$) <i>Note: This cost is applicable only if the required detour duration is greater than 14 days, and is added to the maintenance of traffic (MOT) cost.</i>			
Proposed SIBC category for the project	Bridge slide with diverting traffic on new structure wf ▼		
Specialty contractor cost for SIBC (\$) <i>Note: This cost is estimated based on the contractor availability and qualifications. If the general contractor is self-performing the SIBC operation, this cost need not be included.</i>			
Description	PBES	SPMT move	SIBC
Initial construction cost (\$/sq. ft) <i>Note: This deals with initial construction cost of superstructure and substructure construction, excluding the maintenance of traffic cost, specialty contractor and equipment cost, etc. For each input consider the potential type of superstructure and substructure, and materials to be used with respective bridge construction method.</i>	\$1.00	\$1.00	\$1.00
Bridge preservation cost (\$/sq. ft) <i>Note: This cost needs to include all the costs associated with the repair of structure constructed using respective bridge construction method.</i>	\$1.00	\$1.00	\$1.00
Average duration between the repair activities (year) <i>Note: The data may not be available for the ABC projects. However, analyzing completed ABC projects and related literature, the data can be estimated. The estimates can be more accurate, once large number of ABC projects are available with performance data.</i>	1	1	1
Life expectancy of the structure (year) <i>Note: Consider the proposed superstructure type for respective bridge construction method.</i>	1	1	1
Construction duration (days) <i>Note: This is the duration for which the mobility of traffic is impacted (i.e., mobility impact time).</i>	1	1	1
Detour duration (days) <i>Note: This is the duration for which the facility carried traffic is detoured. This does not include the duration for which the traffic is diverted to temporary run-around.</i>			
Disposal cost or salvage value (\$) <input type="checkbox"/> Edit Values <i>Note: The costs are calculated considering the respective residual life of the structure w.r.t life-cycle cost analysis period. The life expectancy of the structure with CC is considered as the life-cycle cost analysis period. Salvage value is negative.</i>	\$0	\$0	\$0
Discount factor (%) for life-cycle cost analysis 5% ▼ <i>Note: A high discount factor will make the life-cycle cost less important than a low discount factor, and vice-versa. Generally, a discount factor around 3% to 5% is considered reasonable with average close to 4% (FHWA 1998; Thoft-Christensen 2009).</i>			

Figure 3-7. Cost Data datasheet

Preference Ratings: As shown in Figure 3-2a, after completing cost data entry, the next command button allows access to the *Preference Ratings* datasheet (Figure 3-8). The qualitative judgments are assigned in the form of preference ratings on an ordinal scale of 1 to 9 using the *spin buttons*. The user can include their reasoning for the ratings in a text box adjacent to the rating box. The AU completes data entry after entering *Preference Ratings* as *User-1*. The AU can perform the analysis by clicking on the *User-X-OK* button (e.g. *User-1-OK* button for the AU). After that, the AU can select the *Results* command button on the *Advanced User Menu* to view the results.

Following the AU's exit, the program with the data is forwarded to the project team who will access Mi-ABCD as *Basic Users* (BUs) to enter their *Preference Ratings*. The subsequent BUs will be able to see the comments provided in the *Preference Rating* datasheet by the previous users. Only the AU is allowed to see the *Preference Ratings* together with the comments provided by the users. Once the BUs enter their *Preference Ratings*, they can perform the analysis by clicking the *User-X-OK* button (note: *User-1* is the AU; hence, *X* ranges from 2 to 10 for BUs).

When the *Preference Ratings* command button is clicked to display the ***Preference Ratings*** datasheet, a pop-up menu opens asking the question to add a "New User." If an AU is accessing the *Preference Ratings* datasheet to review ratings and comments by all the users, the option *No* is selected. Then, the *Preference Ratings* datasheet shown in Figure 3-9 is displayed and provides the AU with an opportunity to *Delete All Ordinal Scale Ratings and Comments* and *View ratings of all the users*. These options are provided because the software can be used by the MDOT bridge committee to review all the ratings and rationales provided by the users and deliberate over the results. Also, the *Delete All Ordinal Scale Ratings and Comments* option provides an opportunity for the committee to develop a set of ratings during the deliberation process and enter it into the program to evaluate the results of the collective effort.

Results: The analysis results are viewed by clicking the *Result* button in the user menu (Figure 3-2). Figure 3-10 shows the analysis results in three formats: a pie chart, a bar chart, and a line chart. Pie charts describe the results based on upper and lower bound preference

ratings. As shown in Figure 3-10, preference ratings for PBES and SIBC remain at 28% and 23%, while the preference ratings for CC and SPMT move range from 22% to 24% and from 25% to 27%, respectively. The chart on the right of the figure shows distribution of major-parameter preferences from respective users. As an example, the *User-1* preference is heavily weighted on the work zone mobility (WZM) parameter (i.e., 34.3%). That is 11%, 11%, 8.3%, and 4% for CC, PBES, SPMT move, and SIBC, respectively. The percentage distribution of each of the parameter to bridge construction methods is graphically represented in the lower chart of Figure 3-10. Further, the results are shown in a tabular format (Figure 3-11). The first four rows show the contribution of *User-1*'s preferences to each major parameter and the overall preference for CC, PBES, SPMT move, and SIBC.

Preference Ratings				
Advanced User Menu				
Parameter	Rating Significance		Ordinal Scale Rating (1 to 9)	Comments Provided by (User-1):
	1	9		
<i>Note: The background color of parameters (shown below) represent the color of respective Major-Parameter; in the results chart that shows normalized preferences of bridge construction methods.</i>				
<i>Cost Preference Ratings</i>				
Construction cost i CC: \$0.00 M PBES: \$0.00 M SPMT move: \$0.00 M SIBC: \$0.00 M	Not significant	Extremely significant	1	
Maintenance of traffic cost i CC: \$0.001 PBES: \$0.001 SPMT move: \$0.001 SIBC: \$0.001	Not significant	Extremely significant	1	
User cost i CC: \$0.000 PBES: \$0.000 SPMT move: \$0.000 SIBC: \$0.000	Not significant	Extremely significant	1	
Life-cycle cost i CC: \$0.00 M PBES: \$0.00 M SPMT move: \$0.00 M SIBC: \$0.00 M	Not significant	Extremely significant	1	
SPMT move specific cost i \$0.648	Not significant	Extremely significant	1	
SIBC specific cost i \$0.000	Not significant	Extremely significant	1	
Utility relocation cost i \$0.000 (representative value) due to utility work at staging area and/or travel path	Not significant	Extremely significant	1	
<i>Site-Specific Preference Ratings</i>				
Economic impact on surrounding businesses i	Low impact	High impact	1	
Closure of curb-lanes on the bridge i	Not possible	Highly possible	1	

Figure 3-8. Preference Ratings datasheet

Preference Ratings				
<input type="checkbox"/> View ratings of all the users		Advanced User Menu Edit/View My Ratings		
Delete All Ordinal Scale Ratings and Comments				
Parameter	Rating Significance		Comments Provided by (User-2):	Comments Provided by (User-1):
<small>Note: The background color of parameters (shown below) represent the color of respective Major-Parameter in the results chart that shows normalized preferences of bridge construction methods.</small>		1	9	
<i>Cost Preference Ratings</i>				
Construction cost <small>CC: \$0.000 M PBES: \$0.000 M SPMT move: \$0.001M SIBC: \$0.000 M</small>	Not significant	Significant		
Maintenance of traffic cost <small>CC: \$0.001 PBES: \$0.001 SPMT move: \$0.001 SIBC: \$0.001</small>	Not significant	Significant		
User cost <small>CC: \$0.000 M PBES: \$0.000 M SPMT move: \$0.000 M SIBC: \$0.000 M</small>	Not significant	Significant		
Life-cycle cost <small>CC: \$0.000 M PBES: \$0.000 M SPMT move: \$0.001M SIBC: \$0.000 M</small>	Not significant	Significant		
SPMT move specific cost <small>\$0,648</small>	Not significant	Significant		
SIBC specific cost <small>\$0,000</small>	Not significant	Significant		
Utility relocation cost <small>\$0,000 (representative value) due to utility work at staging area and/or travel path</small>	Not significant	Significant		
<i>Site-Specific Preference Ratings</i>				
Economic impact on surrounding businesses	Low	High		

Figure 3-9. Preference Ratings datasheet when accessed as an Advanced User

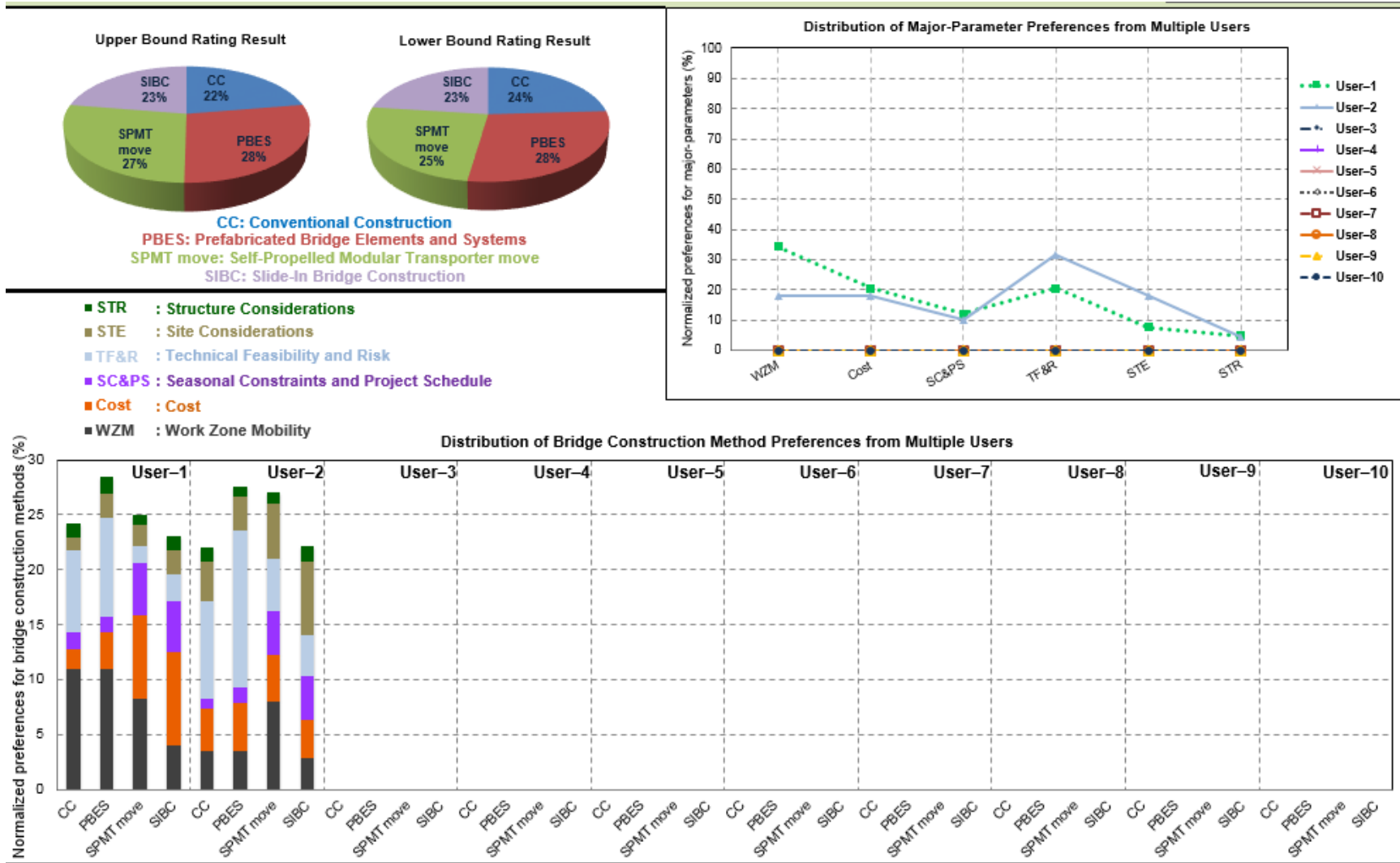


Figure 3-10. Results in chart format

Users	Bridge Construction Methods	Work Zone Mobility (WZM) (%)	Cost (%)	Seasonal Constraints and Project Schedule (SC&PS) (%)	Technical Feasibility and Risk (TF&R) (%)	Site Considerations (STE) (%)	Structure Considerations (STR) (%)	Overall Preference (%)
User-1	CC	11.0	18	15	7.6	1.1	1.3	24.1
	PBES	11.0	3.3	1.3	9.1	2.1	1.5	28.2
	SPMT move	8.3	7.6	4.7	1.5	2.0	0.8	24.8
	SIBC	4.0	8.5	4.7	2.4	2.2	1.3	22.9
User-2	CC	3.5	3.9	0.8	8.9	3.6	1.3	22.4
	PBES	3.5	4.4	1.4	14.3	3.1	0.8	27.9
	SPMT move	8.0	4.3	3.9	4.8	5.0	1.0	27.4
	SIBC	2.9	3.5	3.9	3.8	6.6	1.4	22.4
User-3	CC	0.0	0.0	0.0	0.0	0.0	0.0	0.0
	PBES	0.0	0.0	0.0	0.0	0.0	0.0	0.0
	SPMT move	0.0	0.0	0.0	0.0	0.0	0.0	0.0
	SIBC	0.0	0.0	0.0	0.0	0.0	0.0	0.0

Figure 3-11. Results in tabular format

3.3 SUMMARY

Benefits of implementing ABC over conventional construction (CC) are discussed in the *Accelerated Bridge Construction Manual* (Culmo 2011) and other publications developed under the sponsorship of the Federal Highway Administration (FHWA) - Every Day Counts Initiatives (FHWA 2013b). However, ABC is not a solution to every site. In order to make ABC a part of their business process, highway agencies are developing ABC policy statements. In the call for projects, the policy statement requires the project selection to be based on the feasibility of ABC. If ABC is not justified for a project, a rationale is required. The process of making ABC decisions needs to be supported by a rational process that utilizes tangible bridge construction parameters, site-specific qualitative and quantitative data, and the heuristic experience of the project engineers. In 2013, Aktan and Attanayake developed a multi-criteria decision-support framework to comparatively assess CC versus ABC, and a guided software program titled *Michigan Accelerated Bridge Construction Decision-support* (Mi-ABCD) tool was developed. In 2015, the framework was updated to include four bridge construction/replacement methods (CC, PBES, SPMT, and SIBC). During this project, the Mi-ABCD was revamped by incorporating the updated framework.

The specific conclusions related to the updated Mi-ABCD are as follows:

1. The tool is expanded and is now capable of comparing CC, PBES, SPMT, and SIBC or any subset.
2. Advantage of the tool is the knowledgebase incorporated that consists of *General Data* (e.g., wage rate of drivers, vehicle operating cost, accident cost, accident rate, etc.). The general data does not require frequent updates and is extensively used during the computation process.
3. The *Advanced User* can display ratings from all the users and the comments. This allows the project team to use the tool to review all the ratings and rationales provided by the users and deliberate over the results.
4. The *Advanced User* is allowed to *Delete All Ordinal Scale Ratings and Comments* and input a new set of ratings generated during the deliberation process to evaluate the results of the collective effort.
5. Project managers are expected to best estimates for several cost categories such as initial construction cost. In a future version, the cost data derived from past projects can be incorporated into the knowledgebase as general data to eliminate input of cost estimates.

6. Service life and maintenance frequency of bridges constructed using PBES, SIBC, or SPMT moves need to be estimated for life-cycle cost calculation. In a future version, the performance data needs to be incorporated into the knowledgebase as general data to minimize user input requirements.



MDOT RC-1618C



Research on Evaluation and Standardization of Accelerated Bridge Construction Techniques

**FINAL REPORT – SEPTEMBER 2017
(PART II)**



Department of Civil & Construction Engineering
College of Engineering and Applied Sciences
Western Michigan University

RESEARCH

4 ECONOMIC IMPACT ANALYSIS OF BRIDGE CONSTRUCTION

4.1 OVERVIEW

Economic impact of a roadway closure and safety within construction zones are two major parameters considered when evaluating bridge construction methods for a specific site. ABC methods are implemented over CC techniques to reduce mobility impact time. ABC procedures are being developed and refined; in the meantime, highway agencies and contractors are gaining experience through implementations and demonstrations. Site complexities, time constraints, and perceived risks increase the project cost by 6% to 21% over CC (Aktan and Attanayake 2015). ABC benefits are expected to offset these costs. ABC benefits include the ability to address seasonal limitations, and a reduction in construction duration, maintenance of traffic cost, lifecycle cost, and economic impact on surrounding communities and businesses. Aktan and Attanayake (2015) qualitatively evaluated the economic impact on surrounding businesses and quantified the economic impact on surrounding communities using a predefined county multiplier. Models were developed during this phase for further quantifying the economic impact parameters.

Quantification models for (a) user cost, (b) environmental cost, and (c) business revenue changes are described in Chapter 2. This chapter presents a comprehensive model to quantify economic impact on surrounding communities and businesses. Cost categories of the economic impact of bridge construction are summarized in Figure 4-1. As shown in Figure 4-1, economic impact is quantified using user cost, environmental cost, and business revenue change. User cost for passenger vehicles and environmental cost due to air pollution, water pollution, and climate change are considered for quantifying economic impact on surrounding communities. Impact of air pollution is quantified considering health cost and general cost. Economic impact on surrounding businesses is quantified by calculating user cost for trucks and business revenue change. The scope of analysis presented in this chapter is limited to the construction duration only, and the impacts during other life-cycle activities, such as Capital Preventive Maintenance (CPM) and Capital Scheduled Maintenance (CSM), are not included.

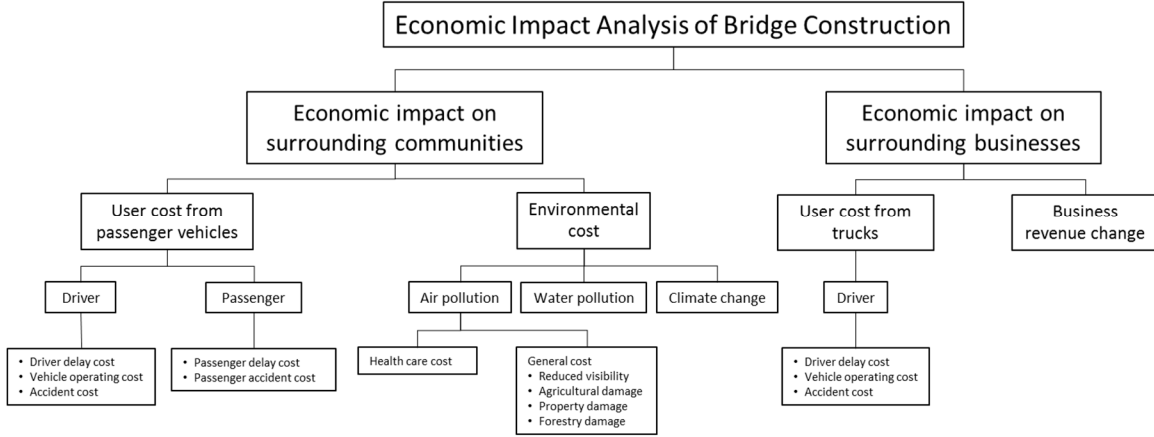


Figure 4-1. The cost categories for economic impact analysis of bridge construction

4.2 ECONOMIC IMPACT ON SURROUNDING COMMUNITIES

As shown in Figure 4-1, economic impact on surrounding communities is evaluated using user cost and environmental cost. User cost includes driver and passenger while the environmental cost includes impact of air pollution, water pollution, and climate change. Impact of air pollution is quantified using health cost and general cost. General cost is due to reduced visibility, agricultural damage, property damage, and forestry damage.

4.2.1 User Cost

Equations 4-1, 4-2, and 4-3 define user cost as driver delay cost (DDC), vehicle operating cost (VOC), and accident cost (AC) respectively (Aktan and Attanayake 2015).

$$DDC = \left[\frac{L}{S_a} - \frac{L}{S_n} \right] \cdot ADT_{pv} \cdot N \cdot w_{pvd} \quad (4-1)$$

$$VOC = \left[\frac{L}{S_a} - \frac{L}{S_n} \right] \cdot ADT_{pv} \cdot N \cdot r_{pv} \quad (4-2)$$

$$AC = L \cdot ADT_{pv} \cdot N \cdot (A_{apv} - A_{npv}) \cdot C_a \quad (4-3)$$

where, 'L' is the length of the affected roadway due to bridge construction (i.e., work zone length); 'S_a' is work zone speed limit; 'S_n' is normal speed limit of roadway; 'ADT_{pv}' is average daily passenger vehicle traffic; 'N' is duration of construction in days affecting the work zone; 'w_{pvd}' is hourly rate for passenger vehicle drivers; 'r_{pv}' is average hourly vehicle operating cost for passenger vehicles; 'A_{apv}' is accident rate per passenger vehicle-mile due to work zone; 'A_{npv}' is

normal accident rate for passenger vehicles; and ‘C_a’ is average cost per accident (includes damage to the driver and the vehicle).

The user cost also includes passenger cost and calculated using the average vehicle occupancy (AVO). AVO represents the number of people in a passenger vehicle, including the driver (Paracha and Mallela 2011). Hence, (AVO -1) represents the number of passengers. Eq. 4-1 and Eq. 4-3 are modified, as shown in Eq. 4-4 and Eq. 4-5, to calculate the passenger delay cost (PDC) and the passenger accident cost (PAC). Vehicle operating cost is not included in the passenger cost, and is only included in the driver cost.

$$PDC = \left[\frac{L}{S_a} - \frac{L}{S_n} \right] \cdot ADT_{pv} \cdot N \cdot w_p \cdot (AVO - 1) \quad (4-4)$$

$$PAC = L \cdot ADT_{pv} \cdot N \cdot (A_{apv} - A_{npv}) \cdot C_{ap} \cdot (AVO - 1) \quad (4-5)$$

where, ‘w_p’ is hourly rate for a passenger and ‘C_{ap}’ is average medical cost per accident per person (i.e., accident cost excluding cost of damages to the vehicle).

During bridge construction, when the facility carried is closed to traffic, a detour route is designated. The user cost due to the additional distance travelled on detour is calculated using Eq. 4-6 to 4-10. These additional costs include driver delay cost (DDC), vehicle operating cost (VOC), accident cost for drivers (AC), passenger delay cost (PDC), and passenger accident cost (PAC).

$$DDC = (T_{Dpv} - T_{WZpv}) \cdot V_{pv} \cdot T_M \cdot w_{pvd} \quad (4-6)$$

$$VOC = (T_{Dpv} - T_{WZpv}) \cdot V_{pv} \cdot T_M \cdot r_{pv} \quad (4-7)$$

$$AC = (L_{Dpv} - L_{WZpv}) \cdot V_{pv} \cdot T_M \cdot A_{npv} \cdot C_a \quad (4-8)$$

$$PDC = (T_{Dpv} - T_{WZpv}) \cdot V_{pv} \cdot T_M \cdot w_p \cdot (AVO - 1) \quad (4-9)$$

$$PAC = (L_{Dpv} - L_{WZpv}) \cdot V_{pv} \cdot T_M \cdot A_{npv} \cdot C_{ap} \cdot (AVO - 1) \quad (4-10)$$

where, ‘T_{Dpv}’ is time to travel via detour for passenger vehicles; ‘T_{WZpv}’ is time to travel along a distance equal to the road segment closed due to construction at the normal posted speed; ‘V_{pv}’ is volume of passenger vehicle traffic on the roadway to be closed during construction; ‘T_M’ is the mobility impact

time; 'L_{Dpv}' is the length of detour for passenger vehicles; 'L_{WZpv}' is the length of the road segment closed to passenger vehicles during construction.

4.2.2 Environmental Cost

Air pollution, water pollution, and other forms of environmental damage are a result of motor vehicle use (Delucci 2000). As it is shown in Figure 4-1, impact of air pollution, water pollution, and climate change are three major categories considered when calculating the environmental cost that contributes to economic impact on surrounding communities. Use of heavy machinery and construction equipment also contribute to environmental cost; however, the procedures presented in this report considers only the passenger vehicle and truck traffic impacts.

4.2.2.1 Air Pollution

Health care cost and general cost are the two major categories of impact from air pollution. General cost represents non-health impacts such as i) reduced visibility, ii) agricultural damage, iii) property damage, and iv) forestry damage.

4.2.2.1.1 Health Care Cost

Health care costs are calculated by using treatment cost data for a variety of disorders related to air pollution due to motor vehicle use. The health-impacting pollutants used in the analysis are carbon monoxide (*CO*), nitrogen dioxide (*NO*₂), volatile organic compounds (*VOC*), and particulate matter (*PM*). Particulate matter considered in this study includes *PM* less than 2.5 microns in aerodynamic diameter (*PM*_{2.5}) and *PM* between 2.5 microns and 10 microns (coarse *PM*₁₀). The cost of a pollutant from passenger vehicles and trucks, when traffic is allowed through work zones during construction, are represented by Eq. 4-11 and 4-12. The cost of a pollutant for passenger vehicles and trucks, when travelling through detour during T_M, are represented in Eq. 4-12 and Eq. 4-14. A speed correction factor (SCF) is used because the emission rate of a pollutant is a function of speed. The emission rates presented in literature is for an average speed and requires modifying if the data shows a statistical difference in speed.

$$CP = UC_p \cdot E_{pv} \cdot ADT_{pv} \cdot N \cdot L \cdot (SCF_{NSpv} - SCF_{WZpv}) \quad (4-11)$$

$$CP = UC_p \cdot E_t \cdot ADTT \cdot N \cdot L \cdot (SCF_{NSt} - SCF_{WZt}) \quad (4-12)$$

$$CP = UC_p \cdot E_{pv} \cdot V_{pv} \cdot T_M \cdot (L_{Dpv} \cdot SCF_{Dpv} - L_{WZpv} \cdot SCF_{NSpv}) \quad (4-13)$$

$$CP = UC_p \cdot E_t \cdot V_t \cdot T_M \cdot (L_{Dt} \cdot SCF_{Dt} - L_{WZt} \cdot SCF_{NSt}) \quad (4-14)$$

where ‘CP’ is cost due to a pollutant; ‘UC_p’ is unit cost of a pollutant, ‘E_{pv}’ is emission of a pollutant from a passenger vehicle; ‘E_t’ is emission of a pollutant from a truck; ‘ADTT’ is the average daily truck traffic; ‘SCF_{NSpv}’ and ‘SCF_{NSt}’ are speed correction factors for normal speed limit within the road segment when there is no construction for passenger vehicles and trucks respectively; ‘SCF_{WZpv}’ and ‘SCF_{WZt}’ are work zone speed correction factors for passenger vehicles and trucks respectively; ‘L_{Dt}’ is the length for detour for trucks; ‘L_{WZt}’ is the length of the road segment closed to trucks during construction; ‘SCF_{Dpv}’ and ‘SCF_{Dt}’ are detour speed correction factors for passenger vehicles and trucks respectively; ‘V_t’ is the volume of truck traffic on the roadway to be closed during construction.

Emission rate of each pollutant is different. Thus, as shown in Eq. 4-15, the total health care cost of passenger vehicles due to pollutants (HC_{pv}) is represented as the summation of cost of each pollutant. Similarly, Eq. 4-16 shows the associated health care cost due to truck traffic (HC_t). Finally, the total health care cost (HC) is calculated as the summation of HC_{pv} and HC_t, as shown in Eq. 4-17.

$$HC_{pv} = CP_{CO} + CP_{NO2} + CP_{VOC} + CP_{PM2.5} + CP_{PM10} \quad (4-15)$$

$$HC_t = CP_{CO} + CP_{NO2} + CP_{VOC} + CP_{PM2.5} + CP_{PM10} \quad (4-16)$$

$$HC = HC_{pv} + HC_t \quad (4-17)$$

4.2.2.1.2 General Cost

General cost is defined as a percentage of health care cost from air pollution. Table 2-11 in *Section 2.2.3.1.2* defines the cost with lower and upper bounds. For the rest of the calculations presented in this report, the average of lower and upper bounds are used (Table 4-1).

Table 4-1. General Cost as an Average Percentage of Health Care Cost

General Cost Category	General Cost (% of Health Care Cost)
Reduced visibility	14.5
Agricultural damage	8.5
Property damage	4.0
Forestry damage	1.0

4.2.2.2 Water Pollution

Quantification of water pollution damage from passenger vehicles (WP_{pv}) and trucks (WP_t) due to a bridge construction is shown in Eq. 4-18 and Eq. 4-19. Water pollution damage cost (WP) is calculated as the summation of WP_{pv} , and WP_t using Eq. 4-20. WP is calculated in terms of the number of extra miles a vehicle has to travel due to a detour.

$$WP_{pv} = UC_{wppv} \cdot V_{pv} \cdot T_M \cdot (L_{Dpv} - L_{WZpv}) \quad (4-18)$$

$$WP_t = UC_{wt} \cdot V_t \cdot T_M \cdot (L_{Dt} - L_{WZt}) \quad (4-19)$$

$$WP = WP_{pv} + WP_t \quad (4-20)$$

where ‘ UC_{wppv} ’ is the unit cost of water pollution from a passenger vehicle and ‘ UC_{wt} ’ is the unit cost of water pollution from a truck.

4.2.2.3 Climate Change

The greenhouse gases (GHGs) include CO_2 , CH_4 , N_2O , and CFCs. To express the global warming contributions of different GHGs, the global warming potential (GWP) concept is developed. It is an international standard to express GHGs in terms of an equivalent CO_2 emission.

Impact to climate change (CC) is calculated using the equivalent amount of total CO_2 emissions (E) and the unit social cost of CO_2 (SC_{CO_2}) (EPA 2013). Eq. 4-21 and Eq. 4-22 show the impact to climate change from passenger vehicles and trucks when traffic is allowed in the work zone during construction. Eq. 4-23 and Eq. 4-24 represent the impact to climate change from passenger vehicles and trucks travelling through a detour during T_M . A speed correction factor (SCF) is used to adjust the emissions given for an average speed.

Emission rate of GHGs is different for passenger vehicles and trucks. Hence, total impact to climate change is the summation of impact to climate change from passenger vehicles (CC_{pv}) and trucks (CC_t) (Eq.4-25).

$$CC_{pv} = SC_{CO_2} \cdot E_{pv} \cdot ADT_{pv} \cdot N \cdot L \cdot (SCF_{NSpv} - SCF_{WZpv}) \quad (4-21)$$

$$CC_t = SC_{CO_2} \cdot E_t \cdot ADTT \cdot N \cdot L \cdot (SCF_{NSt} - SCF_{WZt}) \quad (4-22)$$

$$CC_{pv} = SC_{CO_2} \cdot E_{pv} \cdot V_{pv} \cdot T_M \cdot (L_{Dpv} \cdot SCF_{Dpv} - L_{WZpv} \cdot SCF_{NSpv}) \quad (4-23)$$

$$CC_t = SC_{CO_2} \cdot E_t \cdot V_t \cdot T_M \cdot (L_{Dt} \cdot SCF_{Dt} - L_{WZt} \cdot SCF_{NSt}) \quad (4-24)$$

$$CC = CC_{pv} + CC_t \quad (4-25)$$

where ‘ E_{pv} ’ is equivalent amount of total CO₂ emitted from passenger vehicles and ‘ E_t ’ is equivalent amount of total CO₂ emitted from trucks.

4.3 ECONOMIC IMPACT ON SURROUNDING BUSINESSES

User cost and business revenue changes due to bridge construction contribute to economic impact on surrounding businesses.

4.3.1 User Cost

Eq. 4-26, 4-27, and 4-28 represent the driver delay cost (DDC), vehicle operating cost (VOC), and accident cost (AC) for trucks within the work zone during construction (Aktan and Attanayake 2015).

$$DDC = \left[\frac{L}{S_a} - \frac{L}{S_n} \right] \cdot ADTT \cdot N \cdot w_t \quad (4-26)$$

$$VOC = \left[\frac{L}{S_a} - \frac{L}{S_n} \right] \cdot ADTT \cdot N \cdot r_t \quad (4-27)$$

$$AC = L \cdot ADTT \cdot N \cdot (A_{at} - A_{nt}) \cdot C_a \quad (4-28)$$

where, ‘ w_t ’ is hourly rate for a truck driver; ‘ r_t ’ is average hourly vehicle operating cost for a truck; ‘ A_{at} ’ is accident rate per truck-mile due to work zone; and ‘ A_{nt} ’ is normal accident rate for trucks.

Trucks travel along the designated detours when the facility carried is closed. Therefore, user cost needs to include the additional cost due to travel along the detours. Eq. 4-29, 4-30, and 4-31 are used to calculate driver delay cost (DDC), vehicle operating cost (VOC), and accident cost (AC) for trucks travelling through the detour (Aktan and Attanayake 2015).

$$DDC = (T_{Dt} - T_{WZt}) \cdot V_t \cdot T_M \cdot w_t \quad (4-29)$$

$$VOC = (T_{Dt} - T_{WZt}) \cdot V_t \cdot T_M \cdot r_t \quad (4-30)$$

$$AC = (L_{Dt} - L_{WZt}) \cdot V_t \cdot T_M \cdot A_{nt} \cdot C_a \quad (4-31)$$

where, ‘ T_{Dt} ’ is time to travel via detour for trucks; ‘ T_{WZt} ’ is time to travel along a distance equal to the closed road segment due to construction at the normal posted speed for trucks; ‘ V_t ’ is volume of truck traffic on the roadway to be closed during construction; ‘ T_M ’ is the mobility impact time; ‘ L_{Dt} ’ is the length of detour for trucks; ‘ L_{WZt} ’ is the length of the road segment closed to trucks during construction.

4.3.2 Business Revenue Change

Bridge construction disrupts the traffic flow and thus, the customer flow to surrounding businesses. The disruption of the regular flow of customers could result in either positive or negative revenue change. As shown in Eq. 4-32, the business revenue change (ΔR) is directly related to the change in number of customers (ΔC), average expenditure per household (AE), and mobility impact time (T_M).

$$\Delta R = AE \cdot \Delta C \cdot T_M \quad (4-32)$$

Influence area is an important parameter in the quantification of revenue change. In order to collect site specific data or conduct impact mitigation studies, the influence area is needed to be specified. The influence area of a bridge construction project is established by either utilizing the traffic demand models or with a simple evaluation, which is determined depending on the complexity of the road network (WisDOT 2014).

The change in the number of customers is calculated using the number of households without direct access to the influence area during mobility impact time. The influence area map can be

defined by unifying the mid-points of the shortest distances to the closest commercial centers. The number of households in the area without direct access can be calculated using city maps and the traffic network. If the traffic network is large and complex, the manual calculations can be cumbersome. In such cases, the traffic demand models need to be utilized.

As shown in Eq. 4-33, change in the number of customers depends on the number of households without direct access (HWA) during mobility impact time, percent of households without direct access and avoiding the area influenced by the project (P), and the frequency of patronizing a specific business (F).

$$\Delta C = HWA \cdot P \cdot F \quad (4-33)$$

Reasonable estimates of P and F can be used during planning stages. In order to calculate accurate site specific values of P and F, a survey with the following questions can be administered during or just after bridge construction:

- If the bridge is closed to traffic for _____ days, would you still travel to the area influenced by the construction and continue your weekend routine (shopping, eating, etc.)?
- If no, what type of business/store (gas station, party store, grocery store, pharmacy, auto repair, etc.) would you still make an effort to go to?
- How often do you go to the following businesses/stores?
 - Restaurants: _____ per week
 - Party/Liquor Store: _____ per week
 - Gas Stations: _____ per month
 - Pharmacy: _____ per quarter;
 - Auto Repair: _____ per quarter

4.3.3 Case Study – SIBC in Potterville, MI

The M-100 over CN railroad in Potterville, Michigan, is the 3rd sliding project implemented by the Michigan Department of Transportation (MDOT). The bridge was slid into final alignment during a weekend (November 14-15, 2015) with a mobility impact time of 2 days. The total duration of construction activities at the work zone with a reduced speed limits was 237 days. For comparison purposes, conventional construction (CC) is considered, which requires a mobility impact time of

180 days. The detour length, road segment affected by construction activities, speed limits, ADT_{pv} , and ADTT are obtained from the project data. The comparative values of parameters for SIBC and CC are given in Table 4-2. The necessary data is obtained from project data, city maps, and traffic regulations. As shown in Figure 4-2, the length of the affected roadway due to bridge construction (i.e., work zone length, L) is established based on the start and end locations of reduced speed limits. L_D and L_{WZ} are needed separately for passenger vehicles and trucks since the designated detours given in the traffic management plan of the bridge are different. Figure 4-3 shows the length of the detour and the road segment closed to traffic during mobility impact time for passenger vehicles. Figure 4-4 shows the length of the detour and the road segment closed to traffic during mobility impact time for trucks. The detour length is measured in two different segments (L_{Dt1} and L_{Dt2}) since the speed limits are different.

' V_{WZpv} ' and ' V_{WZt} ' are speed limits of the closed section of the road for passenger vehicles and trucks, respectively. ' V_{Dpv} ' and ' V_{Dt} ' are speed limits when travelling through detour for passenger vehicles and trucks.

Table 4-2. General Parameters of the Bridge Project

Parameter	SIBC	CC
T_M	2 days	180 days
N	237 days	-
L	0.5 mile	-
ADT_{pv}	5045 vehicles/day	5045 vehicles/day
ADTT	190 vehicles/day	190 vehicles/day
S_a	25 mph	-
S_n	55 mph	-
L_{WZpv}	1.6 mile	1.6 mile
V_{WZpv}	55 mph	55 mph
T_{WZpv}	0.029 hr	0.029 hr
L_{Dpv}	4.5 mile	4.5 mile
V_{Dpv}	35 mph	35 mph
T_{Dpv}	0.129 hr	0.129 hr
L_{WZt}	8.5 mile	8.5 mile
V_{WZt}	55 mph	55 mph
T_{WZt}	0.141 hr	0.141 hr
L_{Dt1}	9.8 mile	9.8 mile
L_{Dt2}	3.6 mile	3.6 mile
V_{Dt1}	60 mph	60 mph
V_{Dt2}	55 mph	55 mph
T_{Dt}	0.229 hr	0.229 hr

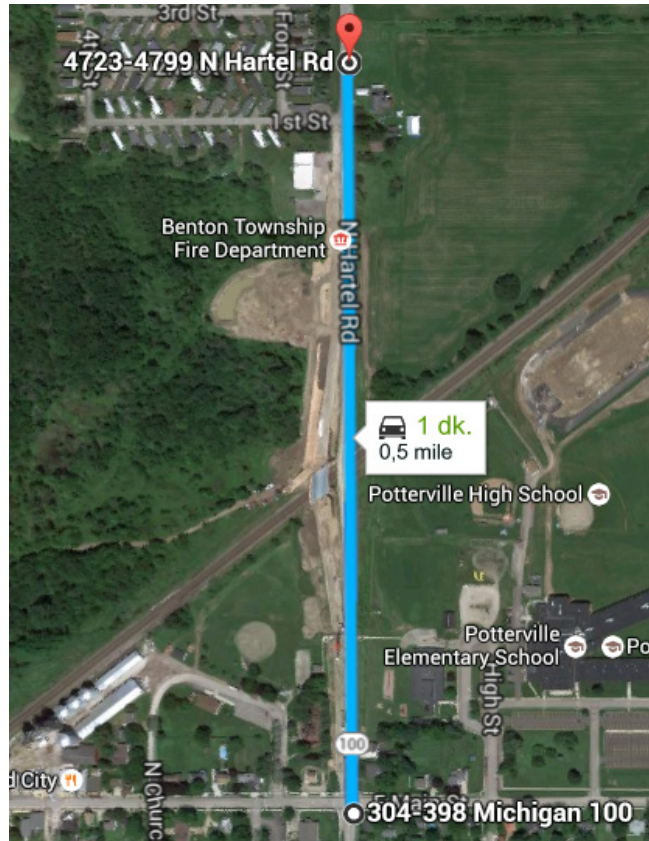


Figure 4-2. Length of the affected roadway due to bridge construction (L)



Figure 4-3. Detour and the closed road segment for passenger vehicles



Figure 4-4. Detour and closed road segment for trucks

4.3.3.1 Economic Impact on Surrounding Communities

The economic impact on surrounding communities includes i) the user cost from the driver and passenger in passenger vehicles and ii) the environmental cost. The site specific parameters for Pottersville needed for the quantification of economic impact on surrounding communities are described in the next section. The cost calculated from the models described in *Section 4.2* is presented for SIBC and CC.

4.3.3.1.1 User Cost

The parameters and databases used for this case study are given in Table 4-3. Definitions and the calculation process of input data are given below;

- Hourly rate of a passenger vehicle driver (w_{pv}) – is calculated by considering the local travel category listed in Table 2-3.
- Hourly rate of a passenger (w_p) - uses 70% of the hourly rate of a driver (w_{pv}).
- Average hourly vehicle operating cost for passenger vehicles (r_{pv}) – is calculated by multiplying vehicle operating cost in dollar per mile with an assumed speed of 55 miles per hour.
- Normal accident rate for passenger vehicles (A_{npv}) – is calculated by dividing the number of total injury level accidents by annual vehicle miles travelled. To calculate a normalized accident rate for passenger vehicles, the ratio is multiplied with the percentage of involvement. In 2014, the total injury level accidents in Michigan was 52,523 and the percentage involvement for passenger vehicles was 77.9% (MOHSP 2014). During the same year, a total of 97.1 billion miles were recorded by all the vehicles in Michigan (MDOT 2016b).
- Accident rate per vehicle-mile due to work zone (A_{apv}) – is calculated by multiplying the normal accident rate for passenger vehicle (A_{npv}) with the average crash modification factor ‘CMF’ (FHWA 2015b).
- Average cost per accident (C_a) and average medical cost per accident per person (C_{ap}) - is calculated based on the minor injury assumption since the speed limits are relatively low (Kostyniuk et al. 2011).
- Average vehicle occupancy (AVO) - obtained for all trip categories from Paracha and Mallela (2011).
- Volume of passenger vehicle traffic on the roadway impacted during construction (V_{pv}) – is made equal to ADT_{pv} with the assumption that 100% of users travel through the designated detour.

Table 4-3. User Cost Parameters of Economic Impact on Surrounding Communities

Data Source	Parameter	SIBC	CC
USDOT 2014	w_{pv}	\$12.67/vehicle/hr	\$12.67/vehicle/hr
USDOT 2014; Litman 2013	W_p	\$8.87/vehicle/hr	\$8.87/vehicle/hr
AAA 2015	r_{pv}	\$31.90/vehicle/hr	\$31.90/vehicle/hr
MOHSP 2014; MDOT 2016b	A_{npv}	4.21 accidents/10 million vehicle miles	4.2 accidents/10 million vehicle miles
FHWA 2014a	CMF	1.77	-
MOHSP 2014; MDOT 2016b; FHWA 2014a	A_{apv}	7.45 accidents/10 million vehicle miles	-
Kostniuk et al. 2011	C_a	\$43,501/accident	\$43,501/accident
Kostniuk et al. 2011	C_{ap}	\$38,579/accident	\$38,679/accident
NHTS 2009	AVO	1.67	1.67
Project data	V_{pv}	5,235 vehicles/day	5,235 vehicles/day

The analysis results are given in Table 4-4 and include the driver delay cost (DDC), vehicle operating cost (VOC), accident cost (AC), passenger delay cost (PDC), and passenger accident cost (PAC). The cost analysis is based on the Potterville-specific data shown in Table 4-2 and Table 4-3. User cost from passenger vehicles with SIBC is slightly below \$725,000 while those with CC is about \$4,640,000. Hence, the user cost contribution to economic impact on surrounding communities during SIBC is under 16% of what it could have been if bridge was constructed using conventional methods.

Table 4-4. User Cost to Surrounding Communities

Cost Category	Route	SIBC	CC	Method
DDC	Work zone	\$165,263	-	Eq.4-1
VOC	Work zone	\$416,091	-	Eq.4-2
AC	Work zone	\$8,426	-	Eq.4-3
PDC	Work zone	\$77,517	-	Eq.4-4
PAC	Work zone	\$5,007	-	Eq.4-5
DDC	Detour	\$12,718	\$1,144,586	Eq.4-6
VOC	Detour	\$32,020	\$2,881,790	Eq.4-7
AC	Detour	\$536	\$48,230	Eq.4-8
PDC	Detour	\$5,965	\$536,871	Eq.4-9
PAC	Detour	\$318	\$28,658	Eq.4-10
	Total	\$723,861	\$4,640,135	

4.3.3.1.2 Environmental Cost

The environmental cost parameters and associated unit costs are given in Table 4-5. Definitions and the calculation process of input data are given below;

- Emissions of passenger vehicles (E_{pv}) – is calculated by multiplying the measured emissions with the corresponding speed correction factor (SCF) for passenger vehicles. Emissions are

measured at 27.6 mph average speed (EPA 2008a and EPA 2008b). SCF for trucks is assumed as ‘1’ due to lack of available data.

- Unit cost of pollutant (UC_p) – uses the values given in *Section 2.2.3.1.1* for passenger vehicles and trucks.
- Unit cost of water pollution from passenger vehicle and truck (UC_{wpv} and UC_{wt}) – uses an average of upper and lower bounds given in *Section 2.2.3.2*.
- Unit cost of water pollution from passenger vehicle (UC_{wpv}) – is calculated by multiplying ‘dollar per passenger miles traveled’ with average vehicle occupancy (AVO). UC_{wpv} is expressed as ‘dollar per mile’ (Delucci and McCubbin 2010; Paracha and Mallela 2011).
- Unit cost of water pollution from trucks (UC_{wt}) – is calculated by multiplying ‘dollar per ton-mile’ values by an average weight of a truck to express the unit cost in ‘dollar per mile’. An average weight of 80,000 lbs (MDOT-Standard Interstate Semi-trailer) is used.
- Social cost of carbon dioxide (SC_{CO_2}) – uses values presented in *Section 2.2.3.3*. The speed correction factor (SCF) is assumed as ‘1’ for quantification of climate change cost, indicating that the emission of GHGs does not vary within the speed limit range used in this case study of 25 mph - 60 mph. Hence this parameter is not included in Table 4-5.
- CO_2 emission from passenger vehicles and trucks (E_{pv} and E_t) – is calculated by dividing the equivalent value of CO_2 emitted by a passenger vehicle or a truck by the total miles travelled by each respective vehicle category throughout the U.S. The corresponding values for 2013, given in EPA (2015) and FHWA (2013a), are used.

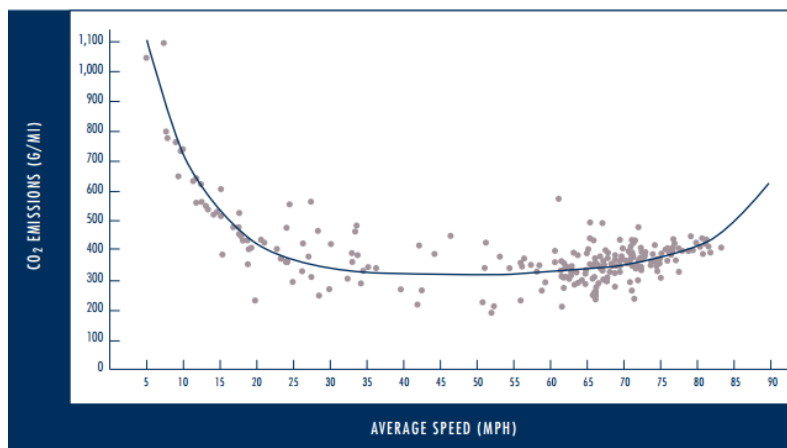


Figure 4-5. CO_2 Emissions vs speed for gasoline passenger vehicles

Table 4-5. Environmental Cost Parameters of Economic Impact on Surrounding Communities

Data Source	Parameter	SIBC	CC
EPA 2008b	E_{pv} (VOC)	2.2708×10^{-3} lbs/mile	2.2708×10^{-3} lbs/mile
EPA 2008b	E_{pv} (CO)	20.7235×10^{-3} lbs/mile	20.7235×10^{-3} lbs/mile
EPA 2008b	E_{pv} (NO _x)	1.5278×10^{-3} lbs/mile	1.5278×10^{-3} lbs/mile
EPA 2008b	E_{pv} (PM _{2.5})	0.0090×10^{-3} lbs/mile	0.0090×10^{-3} lbs/mile
EPA 2008b	E_{pv} (PM ₁₀)	0.0097×10^{-3} lbs/mile	0.0097×10^{-3} lbs/mile
EPA 2015; Highway Statistics 2013	E_{pv} (CO ₂)	0.736 lbs/mile	0.736 lbs/mile
EPA 2008a	E_t (VOC)	0.9855×10^{-3} lbs/mile	0.9855×10^{-3} lbs/mile
EPA 2008a	E_t (CO)	5.0949×10^{-3} lbs/mile	5.0949×10^{-3} lbs/mile
EPA 2008a	E_t (NO _x)	18.9884×10^{-3} lbs/mile	18.9884×10^{-3} lbs/mile
EPA 2008a	E_t (PM _{2.5})	0.4453×10^{-3} lbs/mile	0.4453×10^{-3} lbs/mile
EPA 2008a	E_t (PM ₁₀)	0.4828×10^{-3} lbs/mile	0.4828×10^{-3} lbs/mile
EPA 2015; Highway Statistics 2013	E_t (CO ₂)	7.65 lbs/mile	7.65 lbs/mile
McCubbin and Delucci 1999	UC _p (VOC)	\$0.4935 per pound	\$0.4935 per pound
McCubbin and Delucci 1999	UC _p (CO)	\$0.0395 per pound	\$0.0395 per pound
McCubbin and Delucci 1999	UC _p (NO _x)	\$7.2850 per pound	\$7.2850 per pound
McCubbin and Delucci 1999	UC _p (PM _{2.5})	\$66.9325 per pound	\$66.9325 per pound
McCubbin and Delucci 1999	UC _p (PM ₁₀)	\$56.6405 per pound	\$56.6405 per pound
EPA 2016	SC _{CO2}	\$18.665E-03 per pound	\$18.66E-03 per pound
EPA 2001	SCF _{WZpv} (CO)	1.01	-
EPA 2001	SCF _{WZpv} (NO _x)	1.02	-
EPA 2001	SCF _{NSpv} (CO)	1.34	1.34
EPA 2001	SCF _{NSpv} (NO _x)	1.16	1.16
EPA 2001	SCF _{Dpv} (CO)	1.02	1.02
EPA 2001	SCF _{Dpv} (NO _x)	0.96	0.96
Delucci and McCubbin 2010	UC _{wpv}	\$0.075 per mile	\$0.075 per mile
Delucci and McCubbin 2010	UC _{wt}	\$1.499 per mile	\$1.499 per mile

The analysis results are given in Table 4-6 and includes the costs associated with health care (HC), reduced visibility, agricultural damage, property damage, forestry damage, water pollution (WP), and climate change (CC). The cost calculations are based on the Potterville-specific data shown in Table 4-2 and Table 4-5. Environmental cost with SIBC is about \$7,200, while that with CC is about \$600,000. Hence, the environmental impacts on surrounding communities with SIBC is about 1% of what could have been if the bridge was constructed using conventional methods.

Table 4-6. Environmental Cost to Surrounding Communities

Cost Category	SIBC	CC
Air pollution		
Health care cost	\$1,163	\$67,354
Reduced visibility	\$169	\$9,766
Agricultural damage	\$99	\$5,725
Property damage	\$47	\$2,694
Forestry damage	\$12	\$674
Water pollution	\$4,998	\$449,794
Climate change	\$736	\$66,268
Total	\$7,222	\$602,276

4.3.3.2 Economic Impact on Surrounding Businesses

The economic impact on surrounding businesses includes the user cost from trucks and business revenue change. The site specific parameters for quantification of economic impact on surrounding businesses are described and presented below. The results obtained from the analysis are presented for SIBC and CC.

4.3.3.2.1 User Cost

The user cost parameters and data source are listed in Table 4-7. Definitions and the calculation process of input data are given below;

- Hourly rate for a truck driver (w_t) – is calculated using the local travel category given in Table 2-3.
- Average hourly vehicle operating cost for trucks (r_t) – is calculated in ‘dollar per hour’ by multiplying units of ‘dollar per mile’ with an assumed speed of 55 miles per hour.
- Normal accident rate for trucks (A_{nt}) – is calculated by dividing the number of injury level vehicle accidents by the annual vehicle miles travelled. To calculate normalized accident rate for trucks, the ratio is multiplied with the percentage of trucks involved in accidents. In 2014, total injury level accidents in Michigan was 52,523 and the percentage involvement for trucks is 2.4% (MOHSP 2014). During the same year, a total of 97.1 billion miles were recorded by all the vehicles in Michigan (MDOT 2016b).
- Accident rate per truck-mile due to work zone (A_{at}) - is calculated by multiplying the normal accident rate for trucks (A_{nt}) by the average crash modification factor, CMF (FHWA 2015b).
- Volume of truck traffic on the roadway impacted during construction (V_t) – is taken equal to ADTT assuming that 100% of trucks traveled through the designated detour.

Table 4-7. User Cost Parameters of Economic Impact on Surrounding Businesses

Data Source	Parameter	SIBC	CC
USDOT 2014	w_t	\$24.82/vehicle/hr	\$24.82/vehicle/hr
ATRI 2014	r_t	\$59.18/vehicle/hr	\$59.18/vehicle/hr
MOHSP 2014; MDOT 2016b	A_{nt}	1.30 accidents/100 million vehicle miles	1.30 accidents/100 million vehicle miles
FHWA 2014a	CMF	1.77	-
MOHSP 2014; MDOT 2016b; FHWA 2014a	A_{at}	2.30 accidents/100 million vehicle miles	-
Project data	V_t	190 vehicles/day	190 vehicles/day

The analysis results are given in Table 4-8 and include driver delay cost (DDC), vehicle operating cost (VOC), and accident cost (AC). The cost calculations are based on the Potterville-specific data shown in Table 4-2 and Table 4-7. User cost from trucks with SIBC is about \$43,600 and \$213,350 for those with CC. Hence, the user cost contribution to economic impact on surrounding businesses during SIBC is about 20% of the potential cost if the bridge had been constructed with conventional methods.

Table 4-8. User Cost to Surrounding Businesses

Cost category	Route	SIBC	CC	Method
DDC	Work zone	\$12,192	-	Eq.4-26
VOC	Work zone	\$29,071	-	Eq.4-27
AC	Work zone	\$10	-	Eq.4-28
DDC	Detour	\$700	\$63,020	Eq.4-29
VOC	Detour	\$1,670	\$150,263	Eq.4-30
AC	Detour	\$1	\$73	Eq.4-31
	Total	\$43,644	\$213,356	

4.3.3.2.2 Business Revenue Change

The procedure described in the *Business Revenue Change* section in Chapter 2 is implemented for the Potterville M-100 bridge replacement project. Figure 4-6 shows Potterville city limits and the area selected as the influence area. The part of the city located south of the railway line is defined as the influence area. The area where households without direct access to the influence area during bridge construction is shown in Figure 4-7. Both areas are demarcated using the nearest roads as natural borders, the expected influence of highway, and the detour on passenger vehicle travel patterns.

Business revenue change parameters and data sources are listed in Table 4-9. Definitions and the calculation process of input data are given below;

- Number of households without direct access to the influence area (HWA) - calculated to be 250 from the area defined on the city map.
- Business types - determined based on the common businesses in Potterville.
- Frequency of patronizing a specific business (F) – determined based on a typical household’s needs and activities.
- Average expenditure per household (AE) – calculated using site-specific data from the *GALE Cengage Learning, DemographicsNow* tool. The database was accessed through the Western Michigan University (WMU) Library Services since it requires subscription.

- Percent of households without direct access who are avoiding the area influenced by a project (P) - assumed to be 100%.

Table 4-9. Business Revenue Change Parameters

Data Source	Parameter	SIBC	CC
Maps	HWA	250 households	250 households
Assumption	F (to auto repair shop)	1 visit/90 days	1 visit/90 days
Assumption	F (to party/liquor store)	1 visit/7 days	1 visit /7 days
Assumption	F (to restaurant)	1 visit /7 days	1 visit /7 days
Assumption	F (to gas station)	1 visit /30 days	1 visit /30 days
Assumption	F (to pharmacy)	1 visit /30 days	1 visit /30 days
<i>DemographicsNow</i>	AE (to auto repair shop)	\$42/household/visit	\$42/household/visit
<i>DemographicsNow</i>	AE (to party/liquor store)	\$3/household/visit	\$3/household/visit
<i>DemographicsNow</i>	AE (to restaurant)	\$23/household/visit	\$23/household/visit
<i>DemographicsNow</i>	AE (to gas station)	\$235/household/visit	\$235/household/visit
<i>DemographicsNow</i>	AE (to pharmacy)	\$39/household/visit	\$39/household/visit
Assumption	P	100%	100%

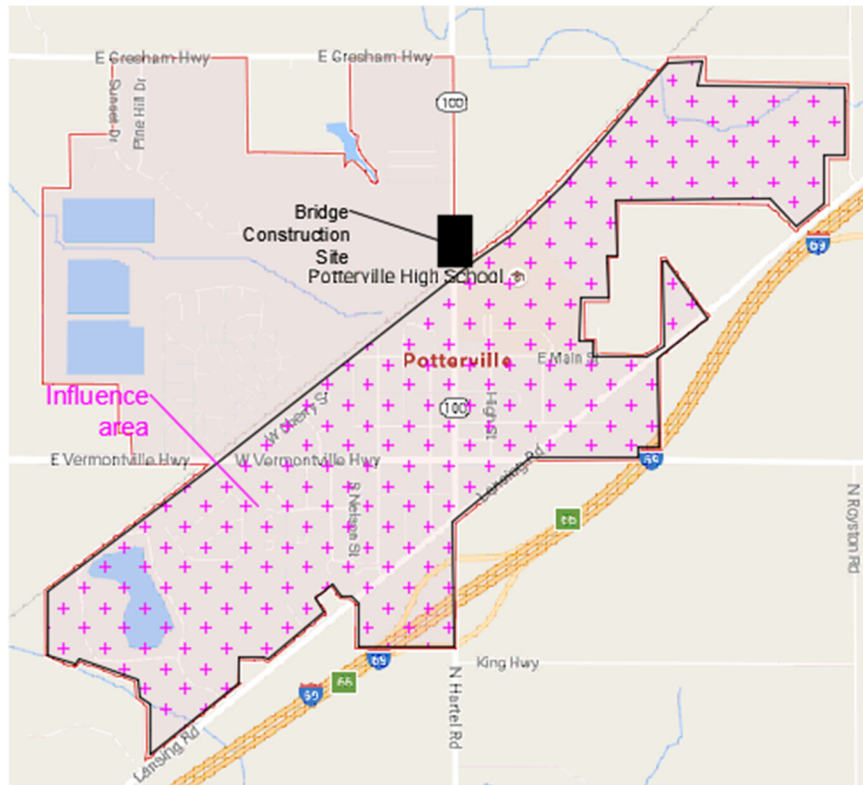


Figure 4-6. Influence area of the bridge project (Commercial center of Pottersville)

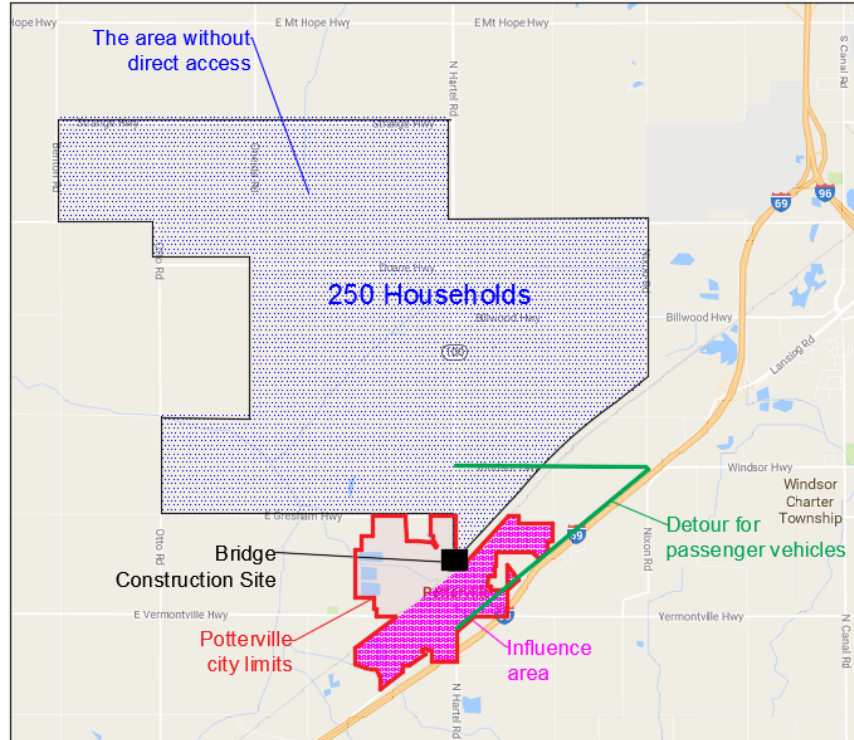


Figure 4-7. Influence area and the area without direct access to the influence area

The business revenue change during mobility impact time, in this particular case, the costs to auto repair shops, party/liquor stores, restaurants, gas stations, and pharmacies located in the influence area are calculated and presented in Table 4-10. The calculations are based on the Potterville specific data shown in Table 4-2 and Table 4-9. The revenue loss with SIBC is about \$6,670, whereas the loss is in excess of \$600,000 with CC. Hence, the economic impact on surroundings businesses due to business revenue loss with SIBC is about 1% of CC.

Table 4-10. Business Revenue Change

Business revenue change	SIBC	CC	Method
Auto repair shop	(\$232)	(\$20,875)	Eq.4-32; Eq.4-33
Party/Liquor Store	(\$211)	(\$19,038)	Eq.4-32; Eq.4-33
Restaurant	(\$1,655)	(\$148,970)	Eq.4-32; Eq.4-33
Gas Station	(\$3,925)	(\$353,250)	Eq.4-32; Eq.4-33
Pharmacy	(\$646)	(\$58,125)	Eq.4-32; Eq.4-33
Total	(\$6,669)	(\$600,258)	

The accurate assessment of business revenue change requires site-specific data for post-construction analysis. Accurate data for the percentage of households without direct access who are avoiding the area influenced by the project (P), and the frequency of patronizing a specific business (F) can be obtained by surveys.

General community and business sample surveys are presented in Appendix C. These surveys are applicable for any size of economic impact analysis with minor modifications based on the site and population characteristics. The survey goals are to collect site-specific data and develop user awareness of ABC. The questions are prepared accordingly to improve the effectiveness of the survey as described in the literature (OQI 2010; Peters 2016). Additionally, the survey rationales are provided to clarify the goal and purpose of the questions.

4.4 SUMMARY

Economic impact of a roadway closure defined as the ‘mobility impact time’ and safety within construction zone are two major parameters considered when evaluating bridge construction methods for a specific site. ABC methods are implemented over CC techniques to reduce the mobility impact time. However, site complexities, time constraints, and perceived risks increase the project cost by 6% to 21% over CC. Nonetheless, ABC incorporates immediate benefits of reduced mobility impact time such as the maintenance of traffic cost, lifecycle cost, construction duration, seasonal limitations, economic impact on surrounding communities, and economic impact on surrounding businesses. Aktan and Attanayake (2015) quantified the economic impact on surrounding communities based on a numerical county economic activity multiplier. However, the economic impact on surrounding businesses was evaluated qualitatively.

A model is developed and presented for quantifying the economic impact on surrounding communities and businesses. The economic impact on surrounding communities is defined as the aggregate value of i) user cost from vehicle driver and passengers and ii) environmental cost due to air pollution, water pollution, and climate change. Economic impact on surrounding businesses is quantified by calculating user cost from trucks and business revenue changes due to limitations in accessing the business because of road closure. The user cost contributes to economic impact on surrounding communities and businesses. User cost is also a parameter which contributes to life-cycle cost. Therefore, it is important to avoid duplication.

The M-100 over CN railroad bridge replacement project is utilized as the case study to demonstrate the application of economic impact analysis models and procedures. In this example, SIBC is compared to bridge replacement with CC in terms of economic impact on surrounding communities which includes user cost from passenger vehicles and environmental cost. Most

significant parameters affecting economic impact on surrounding communities through user cost from passenger vehicles and environmental cost are listed below:

- User cost from passenger vehicles are affected by the total duration of construction activities within the work zone (N), the mobility impact time (T_M), and the length of detour for passenger vehicles (L_{Dpv}).
- The length of detour for trucks (L_{Dt}), speed correction factor (SCF), and truck weight are the contributing parameters for environmental cost.

Table 4-11 presents the economic impact on surrounding communities and businesses. The economic impacts on surrounding communities by SIBC and CC are calculated as \$731,083 and \$5,242,411, respectively. Accordingly, the impact on communities with CC is 7.2 times greater than the impact with SIBC. The significant difference comes from the user cost. The percentage of user cost of economic impact on surrounding communities with SIBC and CC are 99% and 89%, respectively. Hence, environmental cost can be excluded from economic impact on surrounding communities in rural networks. However, it is important to incorporate those effects in the economic impact analysis for more complex road networks (such as high population urban areas) when traffic congestion is often observed.

Economic impact on surrounding businesses, which includes user cost from trucks and business revenue change, is compared for SIBC and CC. Most significant parameters affecting economic impact on surrounding businesses through user cost from trucks and business revenue change are listed below:

- User cost from trucks are impacted by the total duration of construction activities within the work zone (N), the mobility impact time (T_M), and the length of detour for trucks (L_{Dt}).
- Business revenue change is a function of the change in number of customers (ΔC), average expenditure per household (AE), mobility impact time (T_M), number of households without direct access (HWA) during mobility impact time, percent of households without direct access who are averting the area influenced by the project (P), and the frequency of patronizing a specific business (F).

As shown in Table 4-11, the economic impacts on surrounding businesses by SIBC and CC are \$50,313 and \$813,614, respectively. Hence, the economic impact on surrounding businesses by CC is about 16 times greater than the impact by SIBC. User cost and business revenue change contribute to economic impact on surrounding businesses. Similar to economic impact on surrounding communities, user cost is the significant portion of the economic impact on surrounding businesses with 87% for SIBC. However, business revenue change, contributing 74% of the total, increases when mobility impact time is extended with CC. Hence, both parameters are necessary to account for the impact to businesses due to bridge construction.

The overall economic impact due to CC is 7.8 times greater than SIBC. Several assumptions are incorporated in the calculations due to a lack of site-specific data. Two surveys presented in Appendix C can be utilized to collect site-specific data in order to improve the accuracy of the analysis.

Table 4-11. Economic Impact on Surrounding Communities and Businesses

	SIBC	CC
Economic impact on surrounding communities	(\$731,083)	(\$5,242,411)
Economic impact on surrounding businesses	(\$50,313)	(\$813,614)
Total	(\$781,396)	(\$6,056,025)

5 STANDARDIZATION OF SIBC

5.1 OVERVIEW

The construction process and procedures monitored during the US-131 over 3 Mile Road Bridge and the M-50 over I-96 Bridge slides are documented in Aktan and Attanayake (2015). During both projects, the construction complexity was to maintain bridge alignment during slide. In order to understand the reasons and bring clarity to the observed complications, numerical simulation of the US-131 over 3 Mile Road Bridge slide operation was performed and presented in Aktan and Attanayake (2015). The simulation objective was to evaluate the influence of unequal alignment of the temporary substructure and unequal friction between sliding surfaces on maintaining bridge alignment during slide. In addition, slide operations with displacement feedback as well as force feedback were simulated to demonstrate the impact of using different control procedures in bridge slides. Finally, continuous and discrete sliding events were simulated to demonstrate the forces developed in the temporary substructure. The simulation capabilities and the results presented in Aktan and Attanayake (2015) are promising, and can be utilized for the standardization of SIBC. Also, required for standardization is the instrumentation and monitoring of bridge slides to document structural responses in order to quantify forces developed in the system and to calibrate numerical models for future simulations.

This chapter presents an overview of the M-100 over the Canadian National (CN) railroad bridge slide operation, which includes measuring the acceleration response of bridge superstructure during slide, numerical simulation of slide operation, and recommendations for standardizing SIBC design and operation.

5.2 M-100 OVER CN RAILROAD SIBC PROJECT

The M-100 over the CN Railroad bridge slide project activities and observations are documented in this section. The activities are compiled after reviewing the project documents (plans, special provisions, etc.), frequent site visits, and discussions with the MDOT engineers, consultants, and the contractor. The bridge was instrumented and accelerations were recorded during the slide by installing seismic accelerometers on the deck. Two accelerometers were oriented parallel and transverse to sliding directions. The monitoring data was analyzed to calculate the forces developed in the bridge and the temporary structure. In addition, the data was used in the finite

element simulations of the slide. The monitoring of the activities during this project contributed to the recommendations in the report towards standardizing SIBC.

5.2.1 Site Characteristic and Bridge Construction Method Selection

The project site is located in Potterville, Michigan (Figure 5-1). In 2015, the bridge carried an average daily traffic (ADT) of 5,425 with an average daily truck traffic (ADTT) percentage of 3.5%. Insufficient underclearance over the railroad necessitated the bridge replacement. Even though the bridge is not a high profile structure, it connects schools and emergency services to the residential areas in Potterville. In addition, alternative detours for the bridge are significantly longer (Figure 4-3 and Figure 4-4). As a result, SIBC was recommended for this project. The project consisted of construction of a superstructure on a temporary substructure, construction of CIP abutments, and the sliding of the superstructure from temporary to permanent alignment.

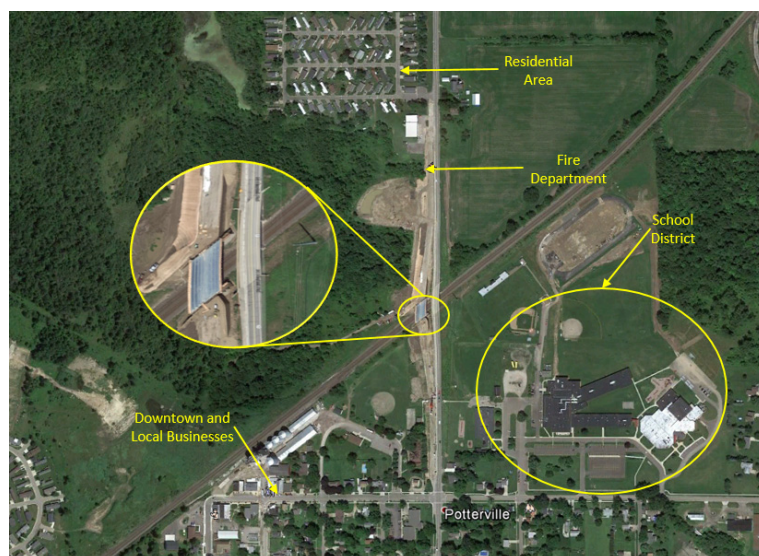


Figure 5-1. Bridge location (Google Earth)

Davis Construction was the general contractor of the project who designed the SIBC components and performed slide activities. The bridge was designed in-house by the MDOT Bridge Design Division. AECOM was the MDOT consultant for the slide operations.

5.2.2 Existing and Replacement Bridge Details

The existing 3-span bridge was 157 ft (47.8 m) long and 43 ft 3 in. (13.2 m) wide with a 38° skew (Figure 5-2a). The new 38° skew, simply supported, single span bridge is 107 ft long (32.7 m) and 57 ft 5 in. (17.5 m) wide (Figure 5-2b). The existing bridge had two 11 ft (3.35 m) wide lanes

and two 9 ft (2.75 m) wide shoulders while the new bridge includes two 12 ft (3.65 m) wide lanes, two 10 ft wide shoulders, and a 10 ft (3.05 m) wide sidewalk (Figure 5-3).



(a) Existing bridge



(a) Replacement bridge

Figure 5-2. M-100 over CN railroad bridge

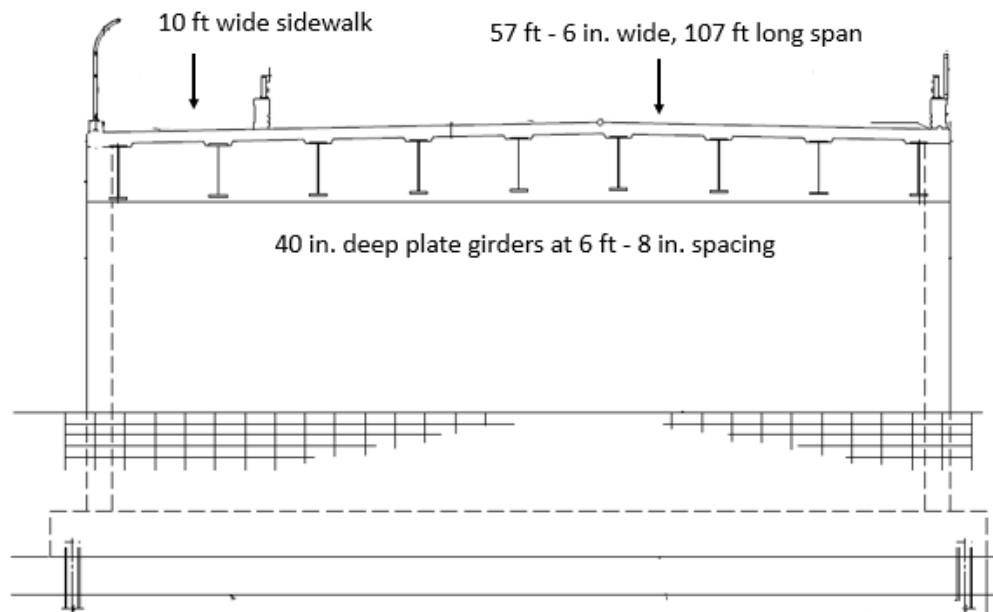


Figure 5-3. Elevation view of the new bridge

5.2.3 Construction and Maintenance of Traffic

The replacement superstructure was constructed on a temporary substructure on the west side and adjacent to the permanent alignment of the bridge. Construction staging and maintenance of traffic (MOT) strategies of the project included the following:

- Temporary structure was constructed. HP 14×73 steel H-piles were driven 60 ft into the ground. Three HP 18×76 sections were welded at the flanges by placing them side-by-side to form the railing girder and supported on the H-piles. C10×20 sections were used for bracing the temporary structure in the direction of sliding. In order to move traffic from the existing superstructure to the replacement superstructure during the demolition of the existing bridge and construction of a replacement substructure, a temporary road was constructed with a fill supported by temporary MSE walls behind the temporary structure (Figure 5-4).

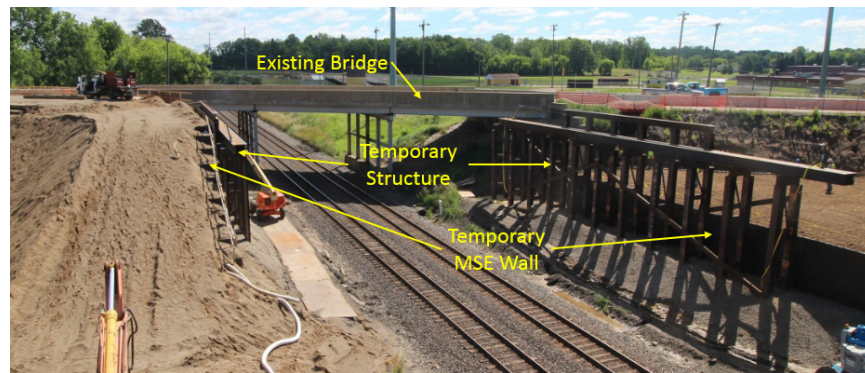


Figure 5-4. Temporary structure

- A bridge superstructure with 40 in. deep plate girders, steel diaphragms, 9 in. thick cast-in-place reinforced concrete slab, and safety barriers was constructed and supported on temporary elastomeric bearings placed over the railing girder (Figure 5-5 and Figure 5-6).



Figure 5-5. New superstructure at temporary location

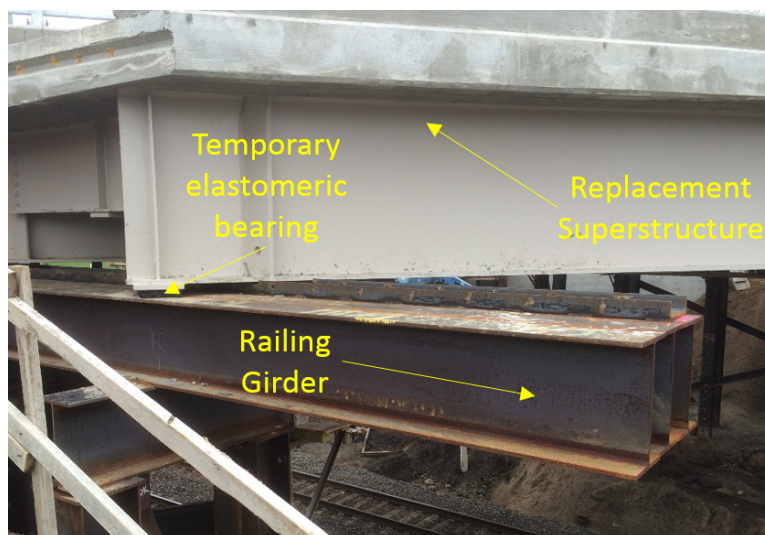


Figure 5-6. New superstructure on temporary elastomeric bearings

- During the removal of the existing substructure and construction of new substructure, M-100 traffic was shifted to the replacement superstructure in temporary alignment (Figure 5-7).



Figure 5-7. Replacement superstructure as the temporary runaround for traffic

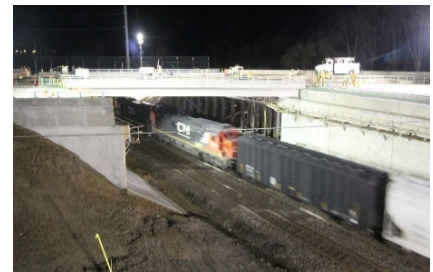
- The railroad was functional during construction and sliding (Figure 5-8). Each time a train was approaching the construction site there was a warning alarm to give notice to the workers. Sliding operation was stopped until the train cleared the bridge.



(a) During the construction of replacement superstructure



(b) During the construction of replacement substructure



(b) During bridge slide

Figure 5-8. Uninterrupted railway operation during bridge construction and slide

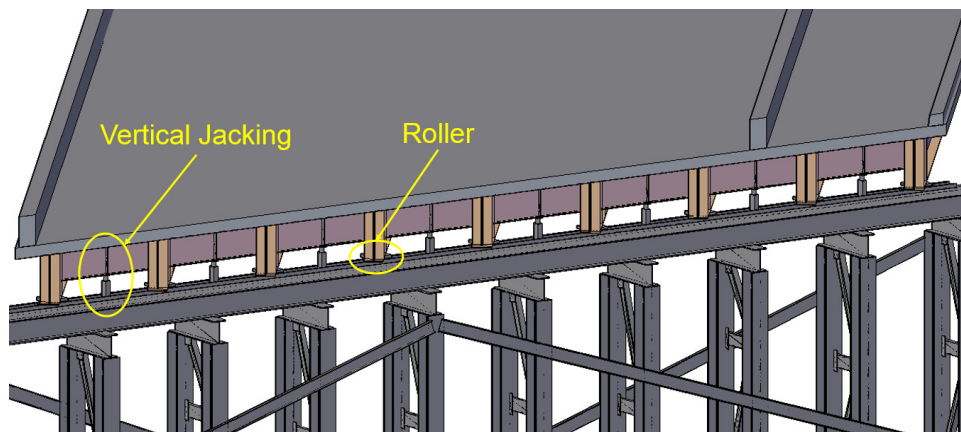
- Traffic was detoured between 7 PM on Friday November 13 to 5 PM on Monday November 16 (Figure 4-3 and Figure 4-4). During the closure, bridge slide was performed.

5.2.4 Pre-Sliding Operations

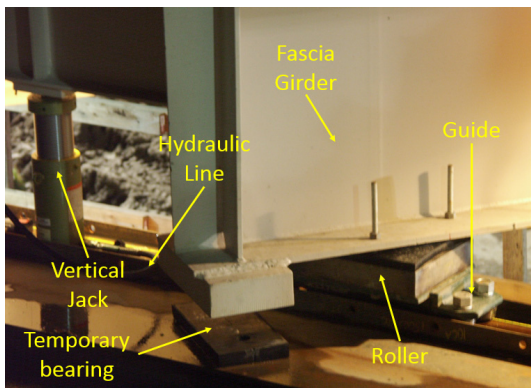
The bridge was closed to traffic at 7 PM on November 13, 2015. The Temporary Concrete Barrier (TCB) walls were removed and bridge slide equipment, including generators and hydraulic power control units, were placed on the deck. Vertical jacks were placed between each girder and under the end diaphragms to lift the bridge for mounting four high capacity sliding rollers under each girder end to facilitate bridge slide (Figure 5-9a and b). Sliding system components are shown in

Figure 5-9b. The rollers set in guides were placed under the fascia beams to maintain sliding alignment.

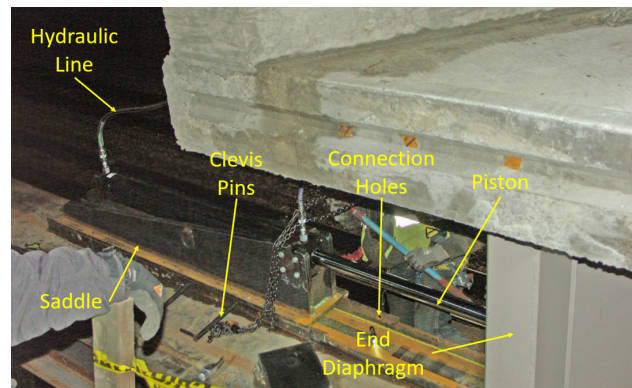
Jacks were connected to a hydraulic power control unit and vertical jacking started at 9:20 PM. Roller placement was completed at 11:30 PM. Once the replacement superstructure was placed on the rollers, two hydraulic actuators were mounted on the west side of each end diaphragm and connected to the superstructure with a clevis support at both the cylinder and the piston end (Figure 5-9c). Double acting hydraulic actuators and the connecting mechanisms provided the ability to push and pull the superstructure as needed. Stroke length and capacity of actuators were 48 in. (1.2 m) and 63.8 kips (283.8 kN), respectively. Pre-sliding operations were completed in 6 hours after the bridge closure (i.e., at 1 AM on November 14).



(a) Elevation view showing vertical jack and roller locations



(b) Sliding system components



(c) Actuating system components

Figure 5-9. Sliding and actuating system components

5.2.5 Sliding Operations

The first push operation of lateral slide started at 1 AM on November 14, 2015. Actuating system components are shown in Figure 5-9c. Every push operation cycle started with mounting actuator

saddles on the slide track with clevis pins (Figure 5-9c). Once the superstructure was pushed and the stroke length capacity was reached, the pins were removed and the piston was retracted. Activities of a one push operation cycle is presented in Figure 5-10. Push operation cycles were repeated until the bridge reached the final horizontal alignment.

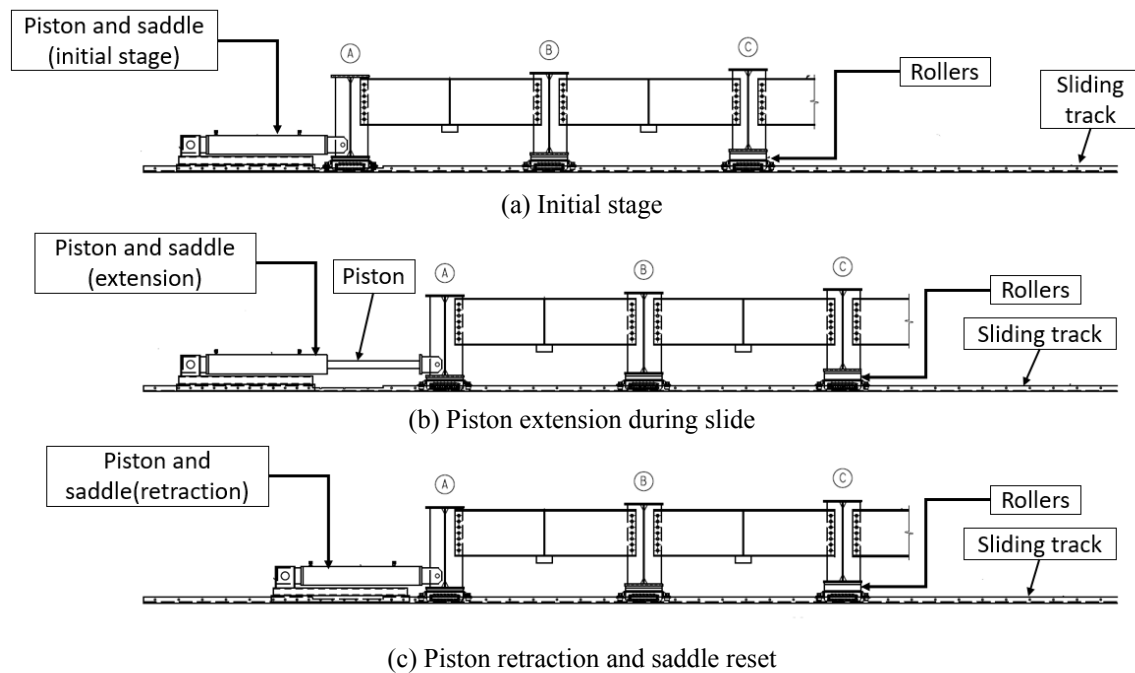


Figure 5-10. Sliding operation sequence

Due to tight tolerances between holes of the guide channels and clevis pins, construction crew had to manipulate the stroke length of each piston to align the pin holes for mounting. Mounting the saddle over the guide channel on the south side was quite cumbersome. The crew needed to use a mallet to drive the pins through the clevis holes in the saddle and the guide track. This made it difficult to maintain equal stroke length between sliding tracks. The time it took to mount the saddles and inability to use full piston stroke delayed the progress. A single cylinder capacity was deemed sufficient to push the superstructure. The contractor chose to disconnect the cylinder on the south abutment. As a result, only one saddle needed mounting and the full stroke of the cylinder could be utilized.

By 8:15 AM on November 14, superstructure was approximately 40 in. away from its final position, and the sliding operation had to be temporarily suspended because the northeast

returnwall was interfering with the slide path (Figure 5-11). This required grinding the returnwall to provide room for the bridge. Finally, the sliding operation was completed at 09:15AM.

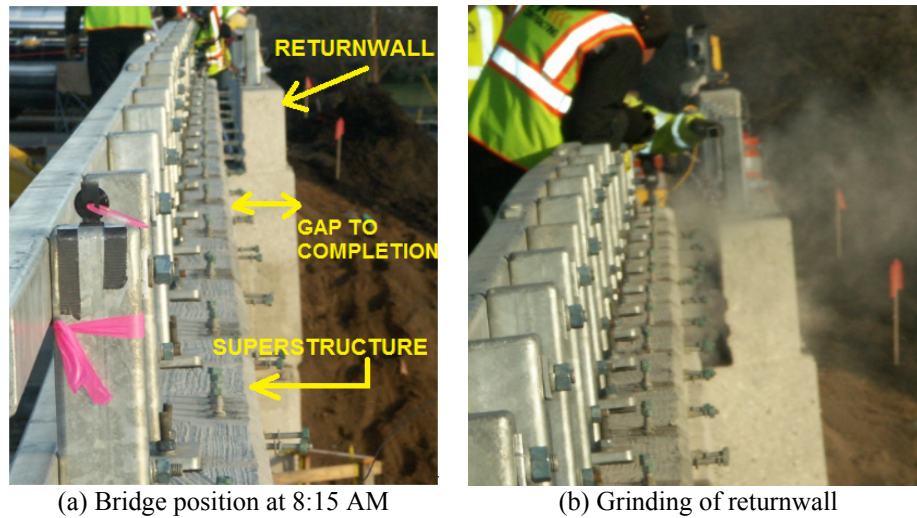


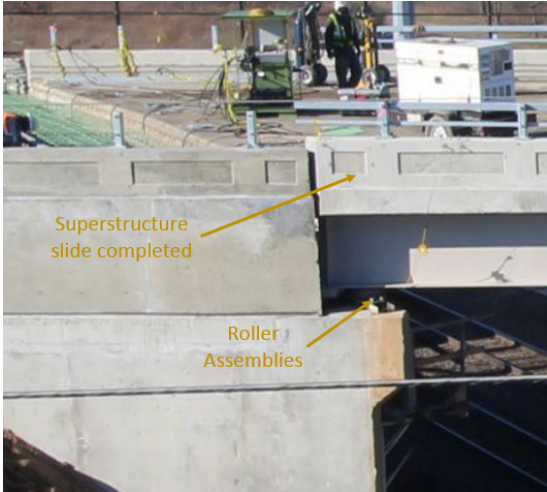
Figure 5-11. Superstructure position at 8:15 AM and returnwall grinding to provide adequate clearance to complete slide

5.2.6 Post-sliding Operations

Bridge slide was completed at 9:15 AM on November 14, 2015. Once in final alignment, superstructure was lifted with vertical jacks to remove the rollers and place the superstructure on permanent bearings. After setting the bearings in place, the superstructure was lowered onto the bearing. The four primary steps executed to place superstructure on permanent bearings are depicted in Figure 5-12.

Once the bridge was at its final alignment, approach slabs were cast with a fast setting concrete mix (Figure 5-13). Finally, the bridge was opened to traffic at 5 PM on November 16, 2015, after approximately 3 days of road closure.

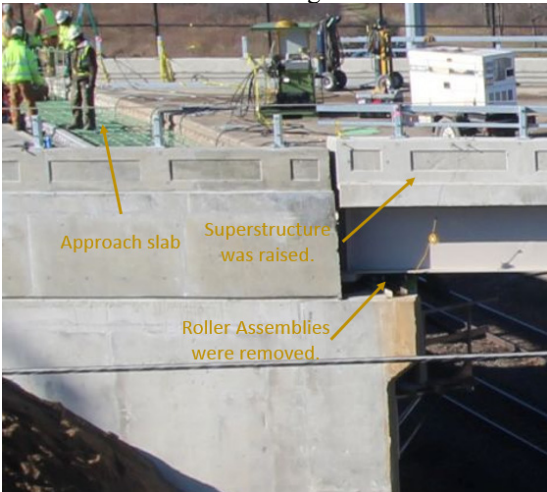
The temporary structure was removed after approximately three weeks from the bridge slide. Figure 5-14 shows the construction site conditions as of December 8, 2015.



(a) Superstructure position when it is at the final horizontal alignment



(b) Superstructure was slightly raised to remove rollers



(c) Superstructure sitting on vertical jacks after removing the rollers



(d) Superstructure on permanent bearings at its final alignment

Figure 5-12. Primary steps involved in placing superstructure on permanent bearings



Figure 5-13. Placement of approach slab



Figure 5-14. View of M-100 over CN railroad bridge site as of December 8, 2015

5.3 INSTRUMENTATION AND MONITORING OF BRIDGE SLIDE

5.3.1 Overview

SIBC design calculations are performed using assumed friction values and structural resistance. Deploying instrumentation to monitor loads and the response of the structural system is useful to verify design assumptions and to help standardize lateral bridge slide operation. Due to the rigorous construction schedule, and sometimes the limited access to a construction site, it is logistically difficult to deploy a comprehensive monitoring system in order to document forces and structural response. As an example, the M-100 bridge was over the CN railroad, and access to the site from the railroad was highly restricted. Hence, the research team could only access the deck temporarily and only one abutment to mount and monitor the instrumentation. For this reason, seismic accelerometers were used to measure superstructure acceleration and quantify the forces acting on the superstructure. This section describes the planning, design, and implementation of the monitoring system as well as the data analysis and interpretation of results.

5.3.2 Instrumentation Planning and Design

With the start of slide operations, access to the bridge deck was limited primarily to the contractor's employees. Further, the M-100 bridge carries traffic over the CN railroad with access limitations from below. After evaluating the access constraints, a remote monitoring system with two seismic accelerometers, a data acquisition system, mounting, and a remote access port were developed (Figure 5-15). Each accelerometer was connected to a power supply unit with an amplifier. Signals were transmitted to a computer with a data acquisition device and recorded through an acquisition software. Data acquisition software was installed in a laptop that was connected to the sensors on the bridge and controlled remotely through a wireless connection and a handheld computer. An outdoor router with an antenna was used to develop a wireless network in the field to facilitate communication between the computers.

Bridge superstructure rotation about its vertical axis (which is referred to as 'yaw' or 'racking') is expected due to differential friction at sliding surfaces (Aktan and Attanayake 2015). In order to capture such movements, mounting at least two accelerometers on the bridge deck (one in the direction of sliding and another in the direction transverse to sliding) was needed. To

accommodate the accelerometers, the fixture shown in Figure 5-16 was fabricated. Three bolts provided at the base allows leveling and adjusting of the accelerometer orientation.

Bridge slide was scheduled for November and the forecast was rainy and cold weather. In order to protect the field computer, data acquisition device, and power supply unit, a weather resistant enclosure was used (Figure 5-17).

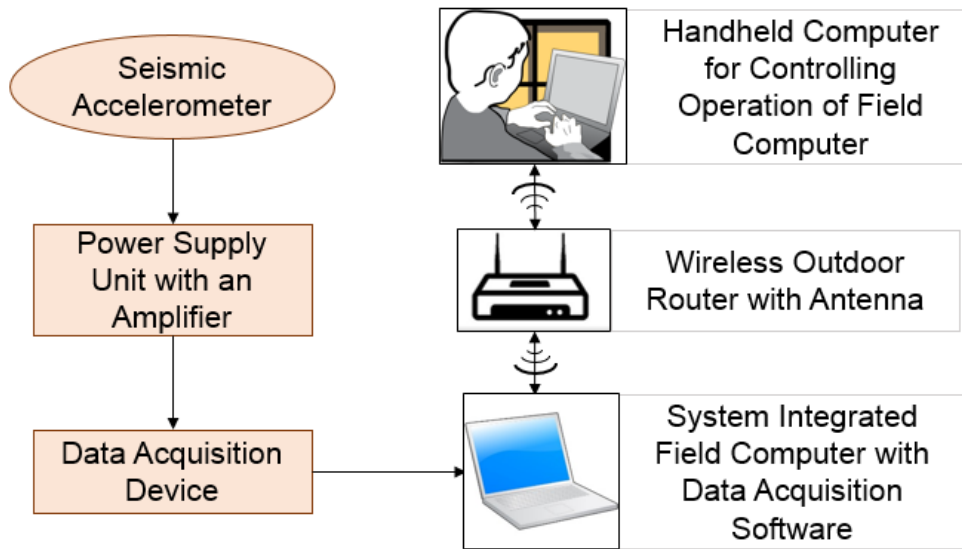


Figure 5-15. Instrumentation plan

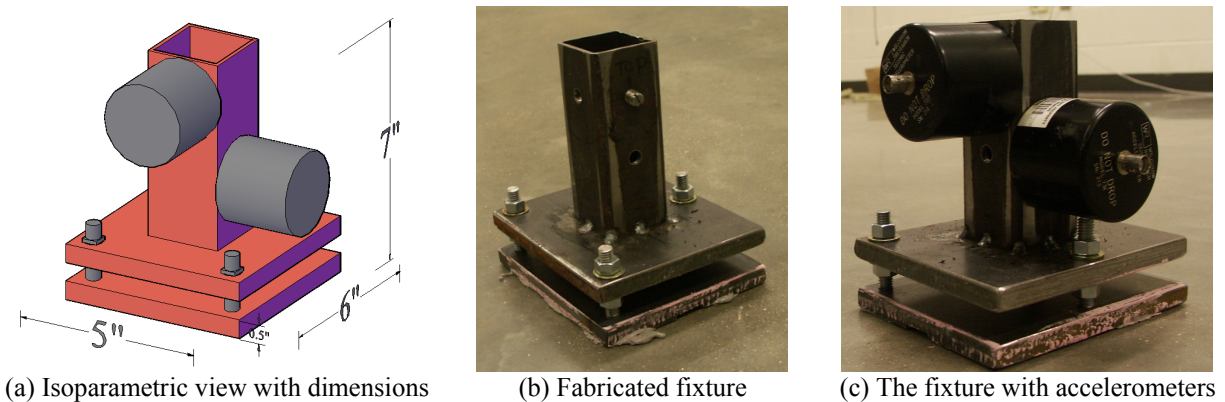


Figure 5-16. Rigid fixture for mounting accelerometers

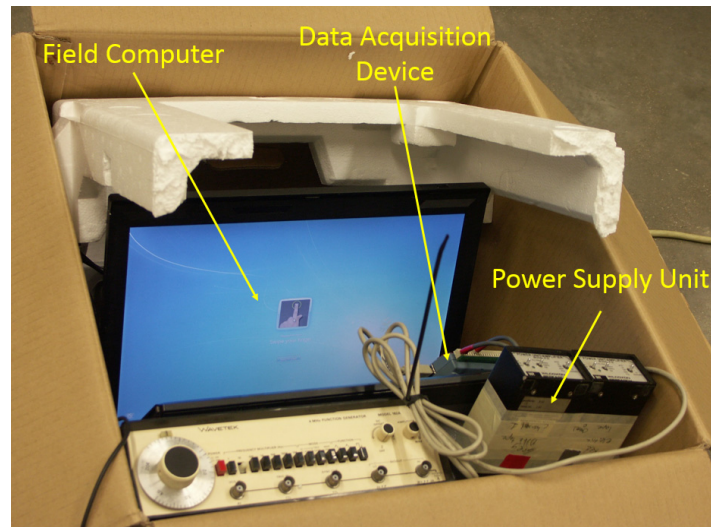


Figure 5-17. Equipment assembly in the box

5.3.3 Data Acquisition System

The data acquisition system included the following components:

- Wilcoxon Model 731 seismic accelerometers,
- Wilcoxon Model P-31 power supply unit with an amplifier,
- PMD-1208LS data acquisition device, and
- TracerDAQ Pro data acquisition software.

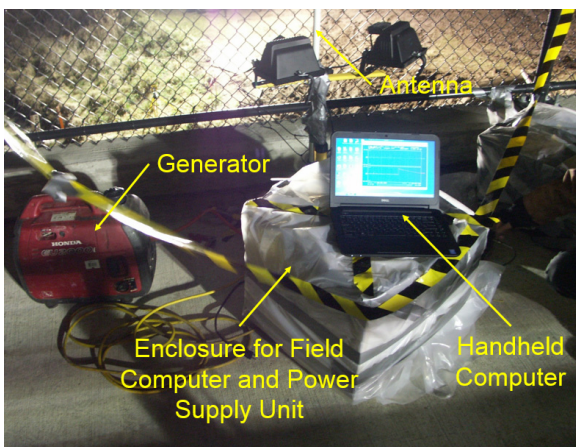
5.3.4 Field Implementation

The new bridge superstructure width accommodates two 12 ft (3.65 m) wide lanes, two 10 ft (3.05 m) wide shoulders, and a 10 ft (3.05 m) wide sidewalk. Instrumentation was located on the sidewalk near the mid span in order to minimize the obstructions to the construction crew members and to reduce risk of damage. Figure 5-18 shows the location of instrumentation, position of the monitoring crew, and the definitions of sliding and transverse directions. Signal strength of the wireless connection was adequate for being about 100 ft away from the router. Based on the site layout, the monitoring crew was positioned in an area close to a newly built abutment (Figure 5-18).

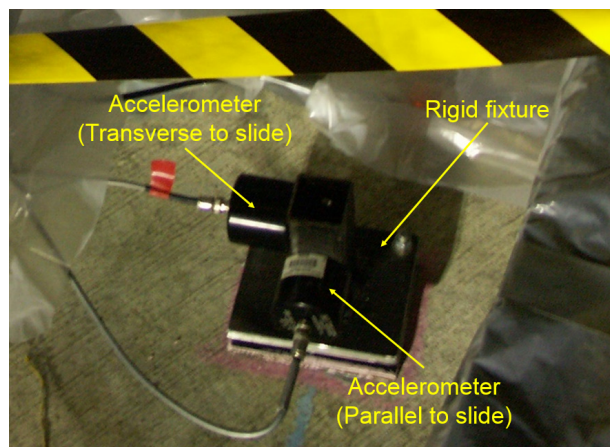


Figure 5-18. Site layout and position of sensors and monitoring crew

The router and the antenna were placed near the fixture. The power supply units for the accelerometers included 9V DC batteries. The lowest ambient temperature at the site was expected to be at 29 °F (-2 °C). Due to restricted access and unfavorable exposure conditions, it was necessary to protect the power supply units to preserve battery power and maintain operation of the monitoring system throughout the entire slide operation. Hence, as shown in Figure 5-19a, the field computer, power supply units, and data acquisition system were placed in a weather resistant enclosure. A generator was used to power the field computer and the flood lights that illuminated the area. Figure 5-19a shows the setup on the bridge with the handheld computer during initial stages of monitoring system configuration and testing. Figure 5-19b shows the accelerometers located on the bridge deck.



(a) Instrumentation setup



(b) Accelerometers

Figure 5-19. Instrumentation setup on the bridge

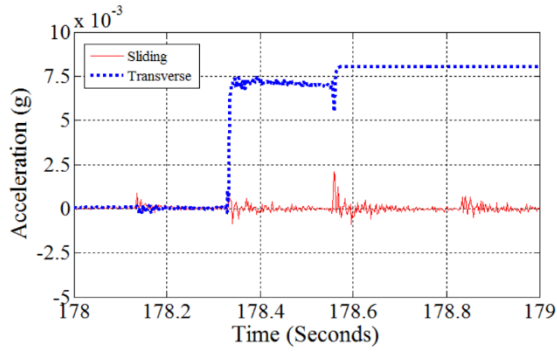
5.3.5 Data Analysis

The bridge slide was performed with a series of discrete push cycles. Data acquisition during each discrete push cycle was synchronized by visually observing the start and end of each event. Due to limited access to the site, only the first five push cycles could be clearly observed and recorded.

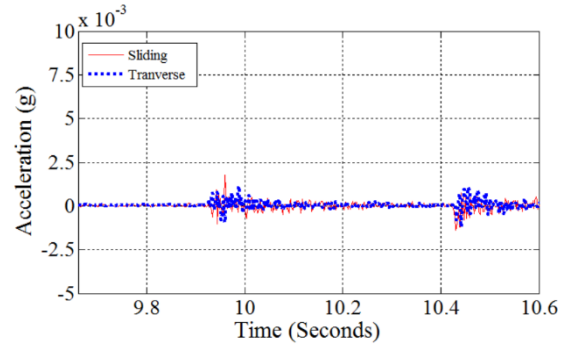
5.3.5.1 Acceleration Data Analysis

Data acquisition rate was set to 500 Hz. Superstructure moved smoothly at a constant velocity except during the beginning and end of each push cycle. Acceleration data at the onset of each push event is shown in Figure 5-20. As shown in Figure 5-20a, at the onset of the 1st push event, a peak acceleration of about 0.0075g was recorded in the direction transverse to slide (where, g is the acceleration of gravity). During the same event, the peak acceleration in the direction of sliding is about 0.002g (Figure 5-20a). Transverse acceleration during the onset of the 1st push is the evidence of a movement in the transverse direction. The movement was restrained at the point where the rollers engaged with the lateral restraints in the slide path.

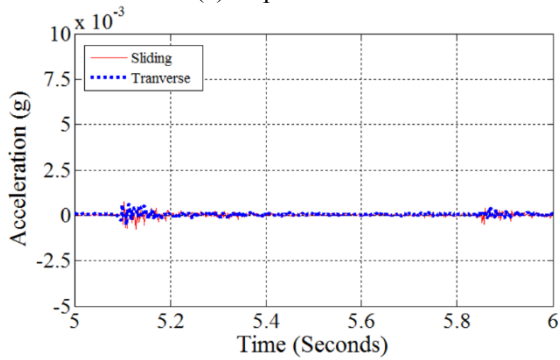
Peak acceleration values recorded during each push event were extracted from data and shown in Figure 5-21. Peak acceleration magnitudes decreased as the sliding proceeded and the transverse restraints remained engaged.



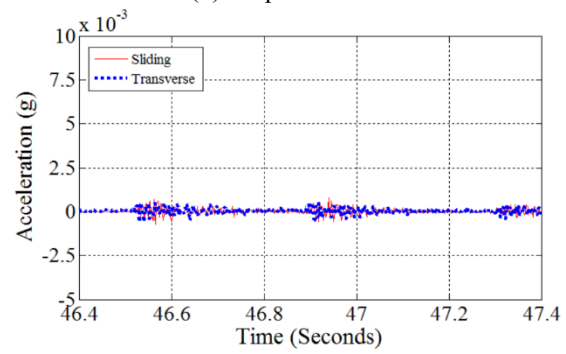
(a) 1st push event



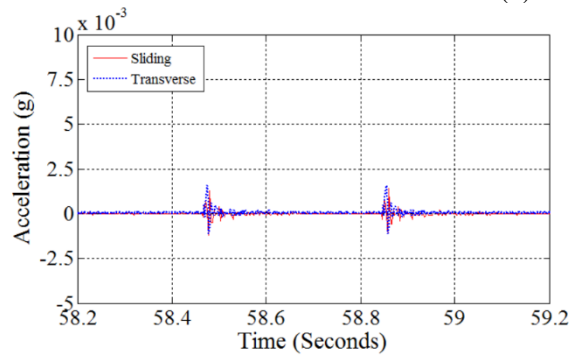
(b) 2nd push event



(c) 3rd push event



(d) 4th push event



(e) 5th push event

Figure 5-20. Acceleration histories during onset of first five push events

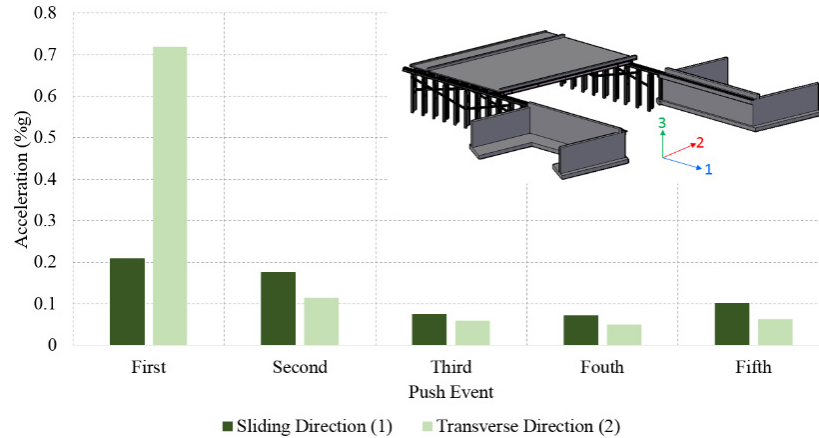


Figure 5-21. Peak accelerations recorded during the first five events

5.3.5.2 Force Generated during the Slide

As described earlier, substructure and actuating system design forces are estimated based on an assumed friction coefficient of the sliding surfaces. Quantification of the forces acting on the system during onset of sliding and during the motion is needed to help standardize bridge slide design and operations. Hence, forces acting on the system are calculated using measured accelerations. For the calculations, superstructure is considered a rigid body. Figure 5-22a shows the center of geometry (C), actuating forces at each sliding track (A_F), friction forces or resisting forces developed at each track (f_{si} , where $i = 1, 2$), and resisting forces develop at transverse restraints due to yaw (R_F). Figure 5-22b shows the net sliding force at each track (ΔF_{si} ; $i = 1, 2$), position of the accelerometers (O) with respect to the direction of sliding and the center of geometry, and the accelerations measured in the direction of sliding and transverse to sliding (a_s and a_t).

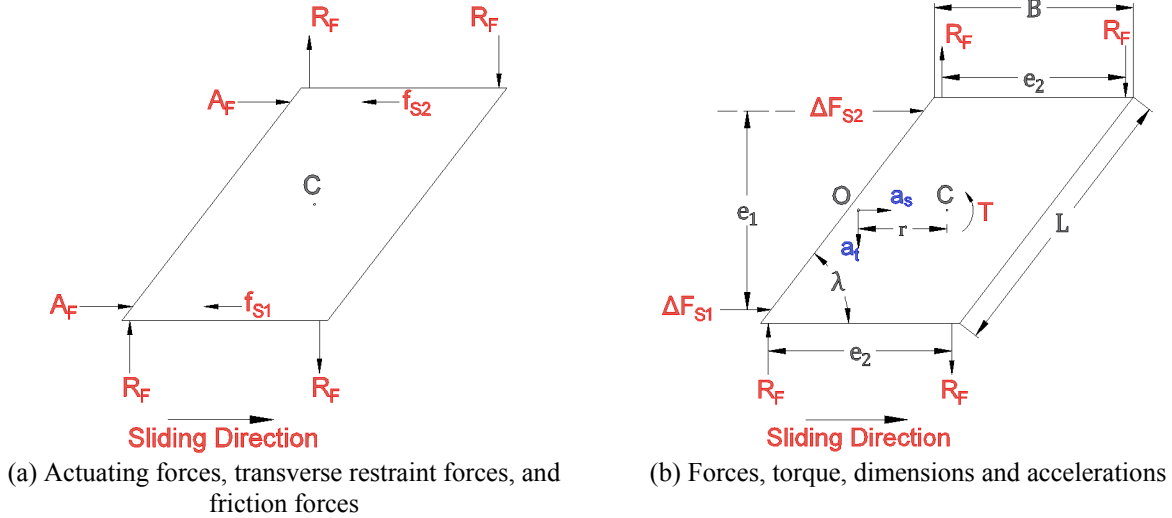


Figure 5-22. Free body diagram of bridge superstructure in motion

First, mass moment of inertia (I) of the superstructure was calculated with respect to the geometric center (C) of the superstructure. Geometric center and the center of mass were assumed to be at the same position. Angular acceleration at the centroid was calculated from transverse accelerations and the mass moment of inertia using Eq. 5-1. Torque acting on the superstructure was calculated from Eq. 5-2. Total net forces in the sliding direction which were acting on each slide track were calculated by considering the forces acting on the system just before the transverse restraints engaged. Total net sliding forces were calculated from superstructure mass, measured acceleration in the sliding direction, and torque. Torque develops from the differences in the sliding forces on each slide track. Total net sliding forces were calculated by solving force equilibrium in the sliding direction and moment equilibrium equations simultaneously (Eq. 5-3). Transverse forces and differential coefficient of friction were calculated using Equations 5-4 and 5-5.

$$\alpha = \frac{a_t}{r} \quad (5-1)$$

$$T = I\alpha \quad (5-2)$$

$$\begin{bmatrix} \Delta F_{s1} \\ \Delta F_{s2} \end{bmatrix} = \frac{1}{2} \begin{bmatrix} 2 & 2 \\ e_1 & -e_1 \end{bmatrix}^{-1} \begin{bmatrix} ma_s \\ T \end{bmatrix} \quad (5-3)$$

$$R_F(\%) = \frac{(\Delta F_{s1} - \Delta F_{s2})e_1}{4We_2} \times 100 \quad (5-4)$$

$$\Delta\mu(\%) = \frac{\Delta F_{s1} - \Delta F_{s2}}{W} \times 100 \quad (5-5)$$

where, r is the distance between the centroid and instrumentation location, α is the angular acceleration at instrumentation location, T is the total torque exerted on the superstructure at centroid, m is the superstructure mass, e_1 is the moment arm of actuation forces, e_2 is the moment arm of transverse forces, W is the superstructure weight, R_F (%) are the resisting forces developed at transverse restraints due to yaw in terms of the percentage of superstructure weight, and $\Delta\mu$ is the coefficient of friction difference between each sliding track. In this report, R_F is referred to as the transverse force.

The net sliding force acting on each track (ΔF_{s1} and ΔF_{s2}) was calculated for the first five push operations and presented as a percentage of the superstructure weight (Figure 5-23). Net sliding force is the difference between the actuating force and the friction force. The actuating forces applied at each sliding track of the M-100 bridge slide operation were equal in magnitude. However, at the onset of the first push, the breakaway friction at the interfaces were significantly different, and sliding started over one track while the friction force over the other track remained greater than the actuating force. As shown in Figure 5-23, at the onset of sliding during the first push, the actuation force over one of the rails was greater than the friction force in the magnitude of 0.65% of the superstructure weight. At the same time, the actuation force over the other rail was lower than the friction force in the magnitude of 0.44% of the superstructure weight. At the onset of the following push events, the force difference over the rails was reduced. As the slide operation continued, the force difference diminished.

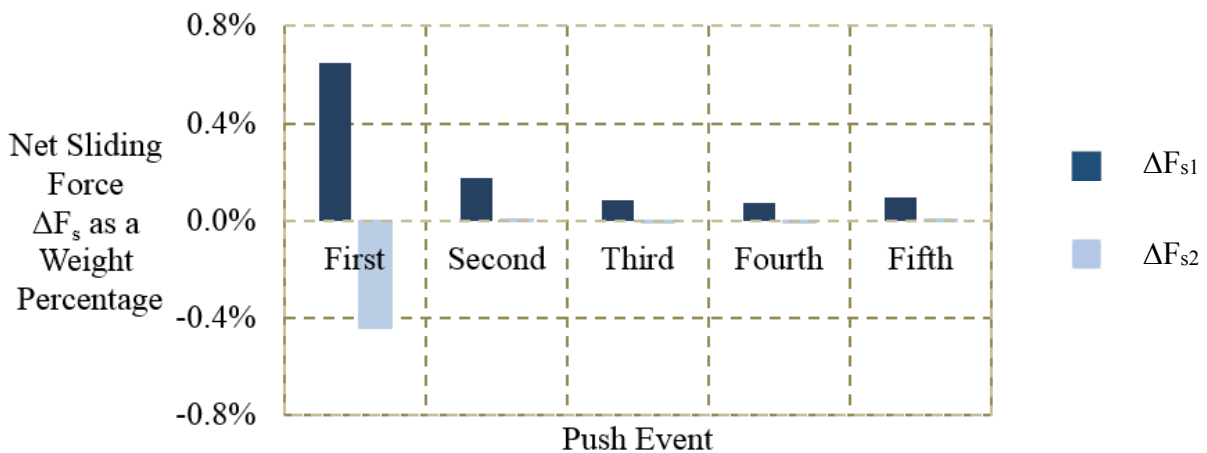


Figure 5-23. Variation of net sliding forces in terms of a percentage of superstructure weight

At the onset of sliding, a torque was developed in the system as a consequence of unequal friction forces on the sliding tracks. This caused superstructure yaw, the rollers got engaged with the transverse restraint and developed transverse forces. Transverse force magnitude, as a percentage of superstructure weight, was calculated using Eq. 5-4. Also, the difference in friction coefficients over each slide rail was calculated as a percentage using Eq. 5-5. Analysis results for each push event documented and monitored during the bridge slide are presented in Figure 5-24. The maximum difference in friction and transverse forces were developed during the onset of sliding during the first push event. For this event, difference in friction coefficient was 1.09%. The corresponding transverse force was 0.63% of the superstructure weight.

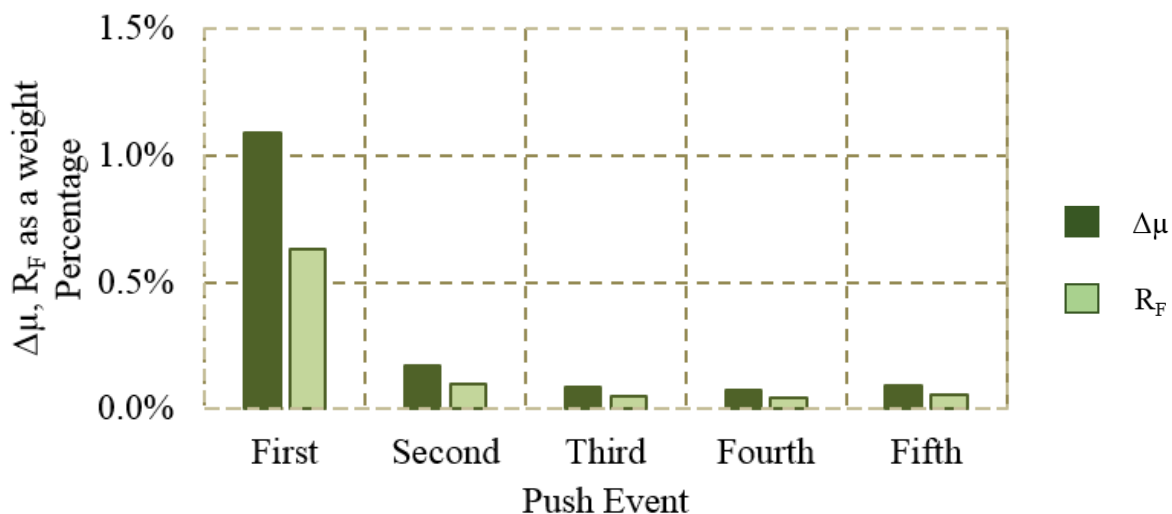


Figure 5-24. Variation of transverse force and difference in friction coefficients

5.3.6 Summary

In this section, monitoring of the M-100 over CN railroad bridge slide and the data analysis are described. The primary objectives were to quantify the difference in friction coefficients between the slide tracks and the transverse forces developed during the slide operation. The following conclusions are based on the monitoring and the data analysis:

1. Acceleration monitoring of bridge slide was adequate for quantifying the transverse force and the differential friction between the tracks. Measuring acceleration in two directions at only one location was also adequate for calculating friction differences between sliding tracks. However, actuating forces should also be monitored to verify sliding forces.
2. A large difference in friction coefficient was calculated between tracks during the first push cycle, creating a large difference in net sliding force between tracks. As a result, a large

transverse force developed. Slide difficulties at the start can lead to difficulties during the following push cycles. It is important to perform test slides to identify and minimize friction differences between sliding tracks.

3. Net sliding forces were calculated for the first push cycle as 0.65% of the weight in slide direction on one track and 0.44% of the weight in reverse direction on the other track. Actuation force overcame friction force on one track resulting in positive net sliding forces. The actuation force was below the friction force on the other track. So the motion started on one track only. This was a result of equal actuation forces resisted by unequal friction forces. Differential friction coefficient between the tracks was calculated as 1% and 0.63% of the weight.
4. A larger difference in friction coefficients between tracks result in developing large transverse forces. A certain level of difference between friction forces is unavoidable. Sliding tracks may be shielded until the start of the slide activity to control the friction and to minimize transverse force development. Another approach could be to initiate small amplitude back and forth movement (dither movement) of the superstructure to eliminate the static to dynamic friction coefficient variation.

5.4 FINITE ELEMENT SIMULATION OF BRIDGE SLIDE

The M-100 over CN railroad bridge slide, described in Section 5.2, is used as the prototype for FE slide simulation. Section 5.3 describes the acceleration response and the resultant forces developed in the system. When rollers are used, most critical forces are developed in the system when the rollers are jammed on one of the railing girders. Hence, sliding operation of the M-100 bridge is simulated and roller jamming on the railing girder at north abutment is considered. Position of the railing girders with respect to the abutments are shown in Figure 5-25. In addition, impact of the actuator jerk during the deceleration of a push event, and load transfer at the connection between the temporary structure and permanent abutments are evaluated.

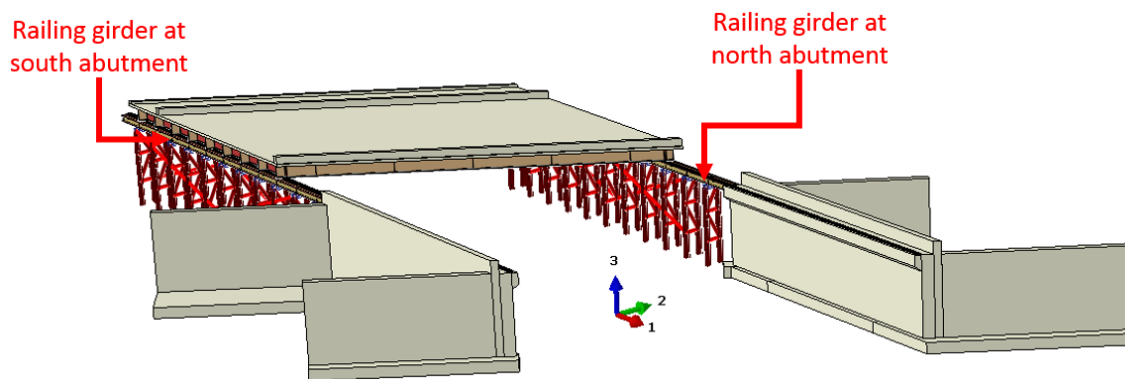


Figure 5-25. M-100 over CN railroad bridge superstructure on the temporary structure

5.4.1 Bridge Geometry, FE Modelling Parameters, and Loads

5.4.1.1 Bridge Geometry

The M-100 bridge geometry and the temporary structure and sliding mechanism details are closely replicated in the model. Minor modifications to the bridge superstructure details are made to reduce the finite element modelling complications that often reduce analysis accuracy. Table 5-1 lists the model components, remarks related to modifications, and element types used to represent each component geometry and behavior.

Table 5-1. Components Included in the Model

Components	Remarks	Element Type
Deck and Barrier	Geometry is simplified.	Solid
Guided Rollers		
Unguided Rollers		
Permanent Abutments	Excluded	N.A.
Haunch Final Bearing Stiffeners		
Girders	Built with shell elements with offset.	Shell
Sliding track		
Temporary Abutment Railing Girder		
Temporary Abutment Piles	Geometry is not altered.	Beam
D1 End Stiffeners and Diaphragms	End Stiffeners and diaphragms are combined and included as one component.	Shell
D2 Interior Stiffeners and Diaphragms		

The bridge superstructure, permanent abutments, and part of temporary structure including railing girders are first modeled in AutoCAD. The components are imported to Abaqus CAE for pre-processing. One dimensional (1-D) beam elements are used to model the members of the temporary structure and the entire geometry is completed in the Abaqus CAE environment. Figure 5-26 and Figure 5-28 show the CAD model. Figure 5-29 shows the bridge superstructure in Abaqus CAE environment. As shown in Figure 5-29 (a), direction 1, 2, and 3 define the sliding, transverse to sliding, and the vertical directions, respectively.

One of the simulation objectives is to evaluate the forces generated during the jamming rollers on one of the railing girders. In developing the simulation model, a restraint is introduced on the sliding track to stop the movement of rollers in the sliding direction. A solid rigid block is attached to the sliding track, located 10 in. away from the front roller over the north abutment, to block the roller movement (Figure 5-27).

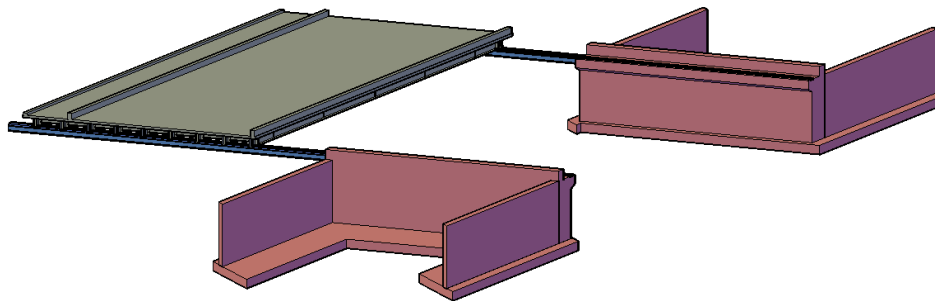


Figure 5-26. CAD model of the bridge superstructure and temporary structure

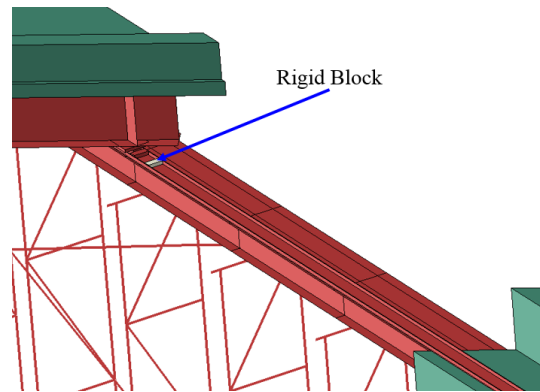


Figure 5-27. A rigid block to provide a sudden restraint to bearing movement (used for simulation of jamming)

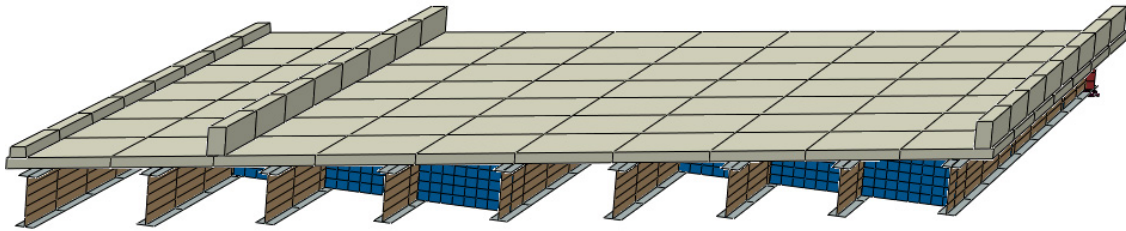


Figure 5-28. Cross-section of the superstructure

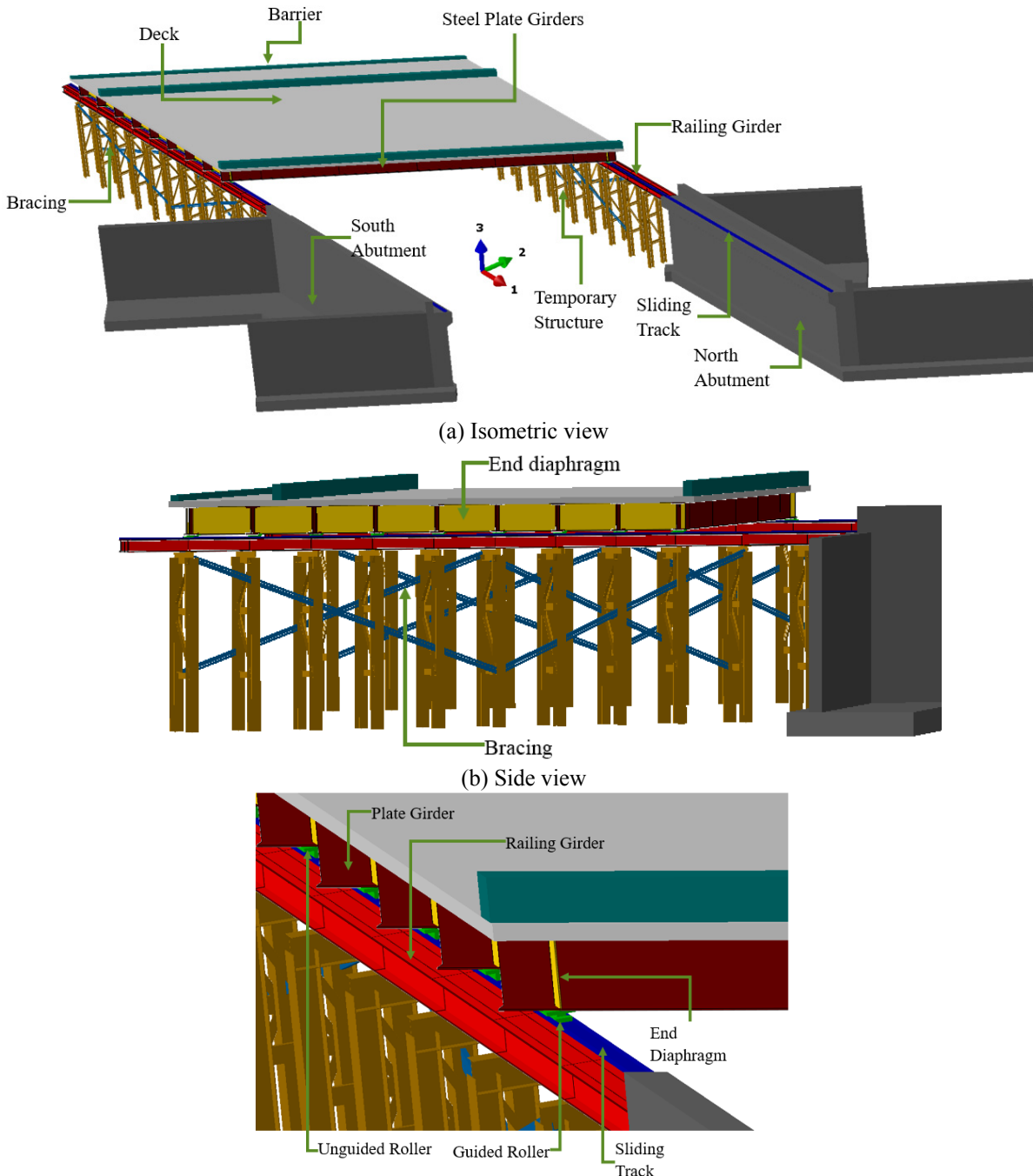


Figure 5-29. Superstructure, temporary structure, and sliding mechanism detail

5.4.1.2 Model Parameters

Modulus of elastic (E), Poisson's ratio (ν), and mass-density (ρ) values are shown in Table 5-2. The modulus of elasticity is calculated using AASHTO (2014) Eq. 5.4.2.4-1. The unit weight of 0.15 kip/ft^3 is used for concrete and converted into mass density as shown in Table 5-2 .

Table 5-2. Material Properties

Materials		Modulus of Elasticity, $E \times 10^6$ (psi)	Poisson's Ratio, ν	Mass Density, ρ ($\text{lb} \times \text{s}^2/\text{in}^4$) $\times 10^{-4}$
Concrete	Deck (Grade D)	3.834	0.2	2.25
Steel (Girders, Stiffeners, Diaphragms)		29	0.3	7.30

Hillman rollers were utilized for the M-100 bridge slide. The breakaway friction coefficient for Hillman rollers is reported as 5% (Hillman n.d.). Since the sliding velocity is slow, a constant friction coefficient of 5% is used in the analysis.

Analysis objectives are to calculate bridge superstructure velocity and acceleration response during each push event, variation of sliding surface stresses, and the forces developed in the temporary structure and at the connection between the temporary structure and permanent substructure. To achieve these objectives, in the FE model, the bridge superstructure is discretized with a coarse mesh while the roller assembly, sliding track, and members of the temporary structures are discretized into elements with aspect ratios that are appropriate for stress calculation. Geometry of the roller assembly is simplified for FE representation; yet the total contact area is maintained. Figure 5-30 shows the FE representation of a guided roller assembly, a sliding channel, new superstructure on temporary structures, and the permanent substructure on the south side.

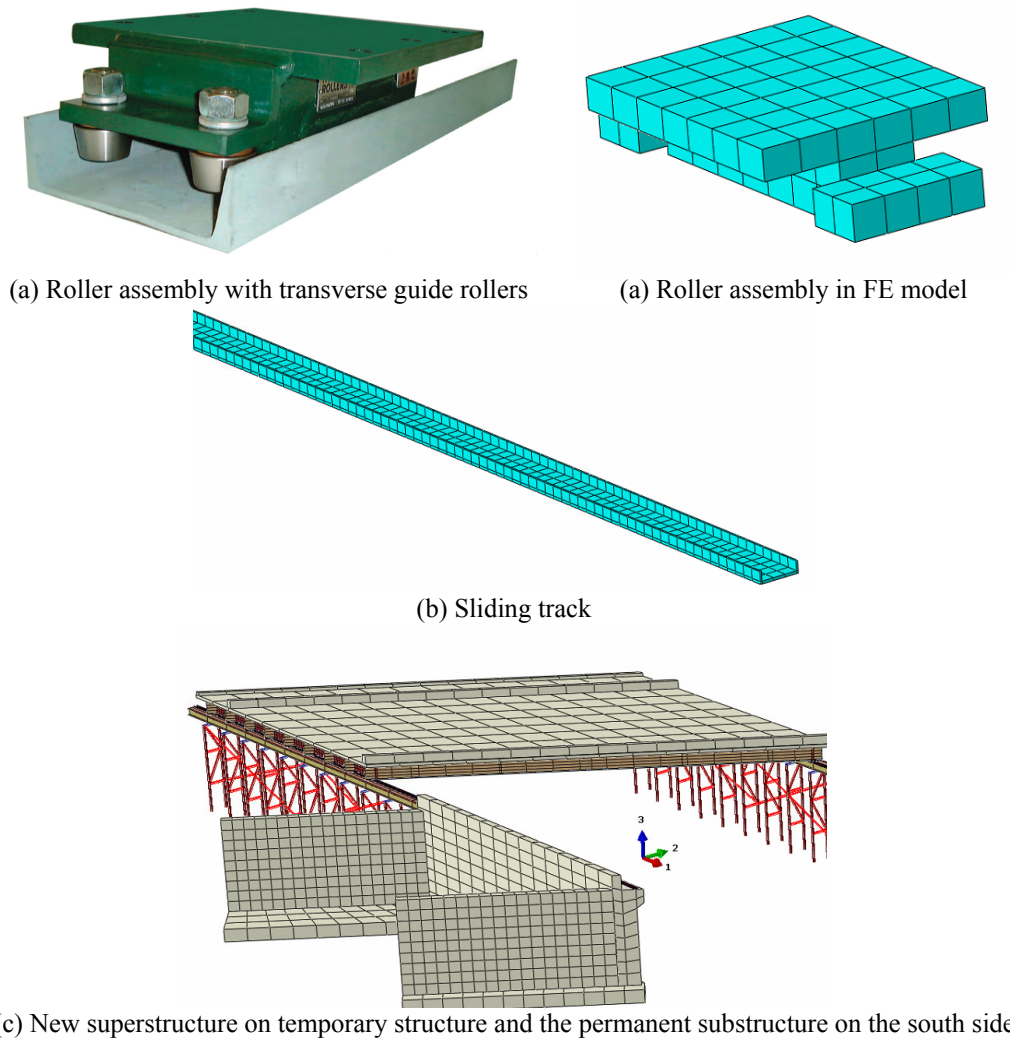
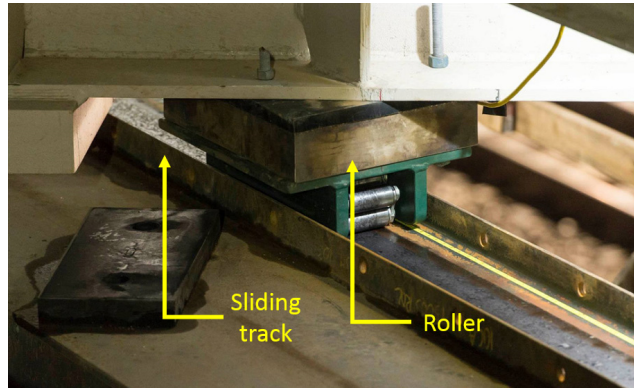
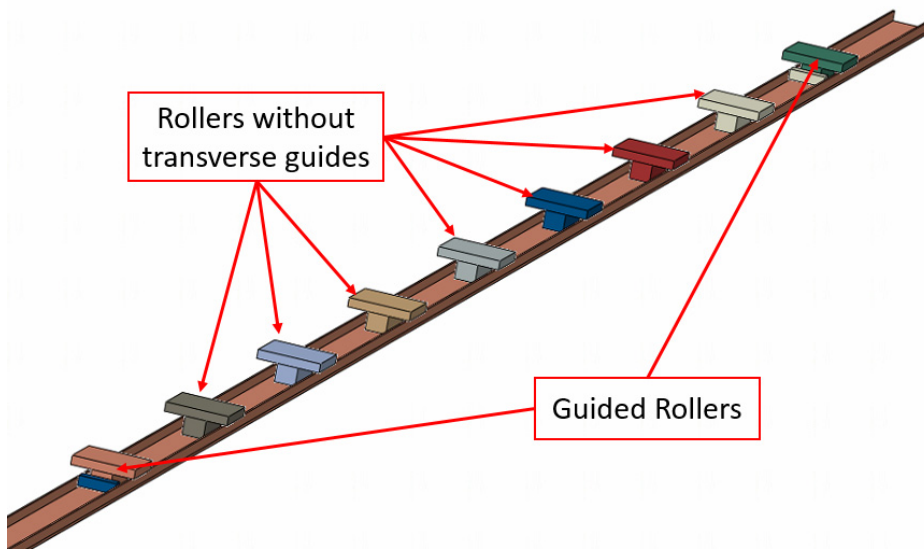


Figure 5-30. FE representation of structural and sliding details

Following FE mesh discretization, the interaction between the components is modelled by contact surfaces or constrains. The contact pair option with penalty contact method is defined for the interaction at the interface between the rollers and the sliding track (Figure 5-31). The contact pair option with frictionless contact is defined for the contact between transverse guide rollers and the side walls of the sliding track. Node-to-surface tie constraint is defined for the interaction between edges of shell elements and shell surfaces, whereas surface-to-surface tie constraint is defined between surfaces. Surface-to-surface tie constraint is also defined for the temporary structure to permanent structure rigid bolted connection. Finally, the extended piles of the temporary structure are constrained at the ground level for translations and rotations simulating fixed support conditions (Figure 5-32). Similarly, fixed supports are assigned to the permanent substructure.



(a) A roller placed in a sliding track



(b) Geometric representation of roller assemblies placed in a sliding track

Figure 5-31. A sliding track and roller assemblies (a) geometry of a roller assembly in a channel and (b) geometric representation in the model

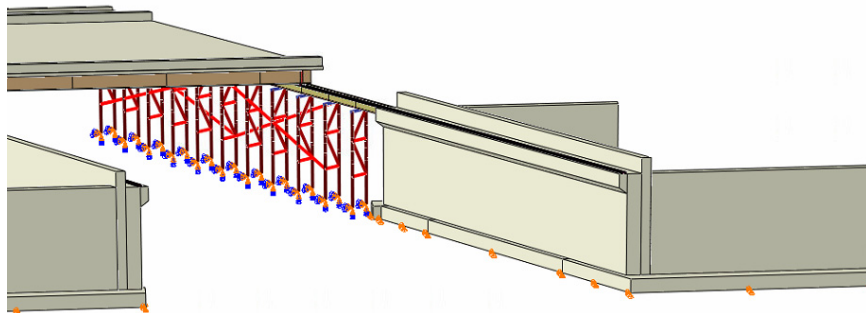


Figure 5-32. Boundary conditions assigned for extended piles and permanent substructure

5.4.1.3 Loads and Applied Forces

Self-weight of the superstructure is applied using the *DLOAD command. Abaqus Explicit is used to perform the sliding simulations. The application of the gravity load acts as an impact force and generates a large dynamic response, which influences the rest of the analysis. In order to suppress the dynamics that are not really occurring, self-weight is applied as a gradually increasing load using the *AMPLITUDE option. For consistent units, the gravitational acceleration is defined as 386 in/s^2 .

As shown in Figure 5-10, the hydraulic actuator is pin-connected to the fascia girder stiffener. Based on the superstructure weight of 900 kips, the vertical force expected on each roller is 50 kips. With 9 rollers on each sliding track and a 5% friction, the maximum pushing (or actuating) force required at each hydraulic cylinder is 22.5 kips. The actuating force applied is 24.4 kips, which is slightly greater than the calculated force based on the assumed friction. As shown in Figure 5-33, the pushing force is applied as a ramp using the *AMPLITUDE option. The pushing force is gradually increased to a value slightly greater than the calculated friction force between t_1 and t_2 . Once the force reached the defined maximum, it is maintained for a short duration between t_2 and t_3 . Then, the force is decreased to zero between t_3 and t_4 . Simulating a typical slide event, the superstructure is allowed to slide freely until the motion stops due to frictional resistance.

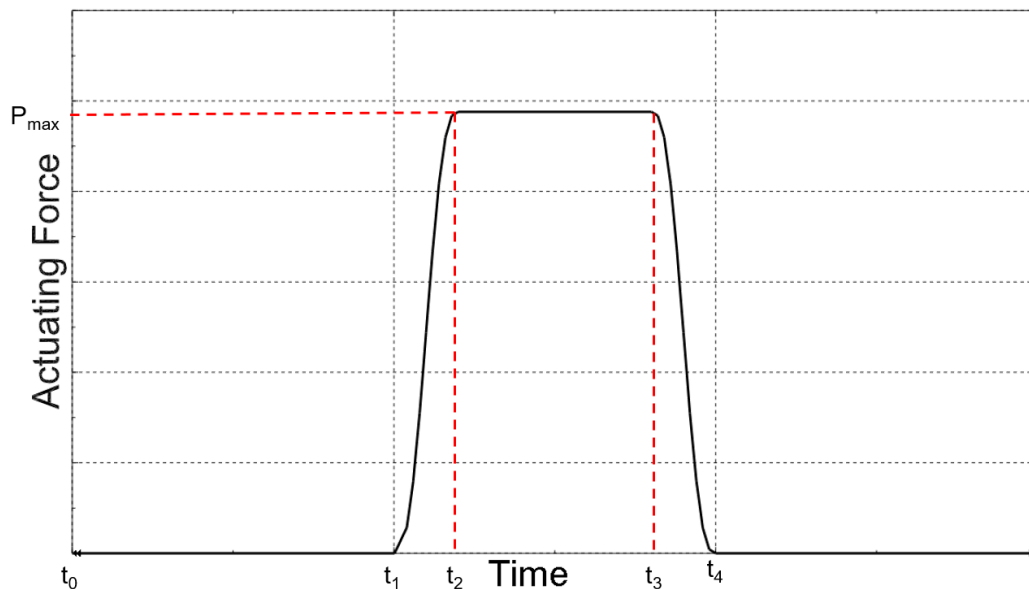


Figure 5-33. Actuating force history

Simulations are performed to calculate the forces developed due to the impact of (a) jamming of rollers on one channel and (b) variation in actuator jerk. Equal friction of 5% is assumed on each sliding surface for simulation of jamming. As shown in Figure 5-27, a rigid solid block is placed in the sliding track on the north side to suddenly stop the bridge movement simulating jamming of rollers. The solid block is placed at 10 in. away from initial position of the superstructure. This allows the superstructure slide 10 in. until the front roller hit the rigid block and thus, suddenly stopping the sliding structure and developing impact forces.

In calculating the effect of actuator jerk, several actuating forces ramp up and down profiles are defined as shown in Figure 5-34. In the first case, the force instantly decreases to zero after maintaining a constant amplitude for a short duration simulating an instant removal of the actuating force. For the other three cases of changing jerk, amplitude is decreased with the rate of 4.88 kips/s, 2.44 kips/s, and 1.22 kips/s by ramping down the load in 10s, 20s, and 40s, respectively.

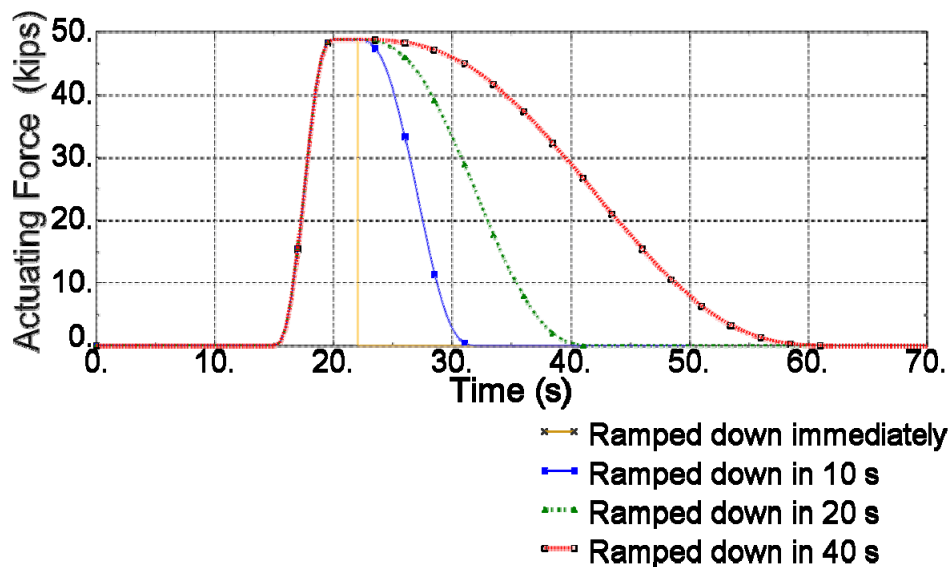


Figure 5-34. Actuating force histories with different jerks

5.4.2 Analysis Results

Analysis results are presented and discussed in the following sections. First, the effect of roller jamming on one of the sliding track is described. Next, the impact of actuator jerk is compared under different rates of force ramp down. Displacement, velocity, and acceleration histories and reaction forces in the sliding direction and the direction transverse to sliding are presented. In addition, the force transfer from the temporary to the permanent structure through the rigid connection is presented.

5.4.2.1 Structural Response to the Jamming of One Roller during a Pushing Event

The analysis deals with the case when one roller on one sliding track is obstructed. A friction coefficient of 5% is defined at each sliding track and the friction force of 22.5 kips is calculated. An actuating force of 24.4 kips is applied at each sliding track following the force amplitude profile shown in Figure 5-33. In this simulation, actuator force was ramped up until the sliding distance reached 10 in., and then the motion was abruptly halted on one sliding track by a solid block placed against the front roller assembly. As shown in Figure 5-27, a rigid block is positioned inside the north railing track at a distance of 10 in. away from the initial position of the superstructure. In this simulation, the superstructure moved 10 in. before colliding with the rigid block.

Displacement and velocity responses of a superstructure are shown in Figure 5-35. Under uniform friction and transverse restrains provided by the sliding track, the superstructure racking was not observed. As a result of the jamming the front roller, sliding velocity is decreased from 3.62 in/s to 0 in/s in 40 milliseconds.

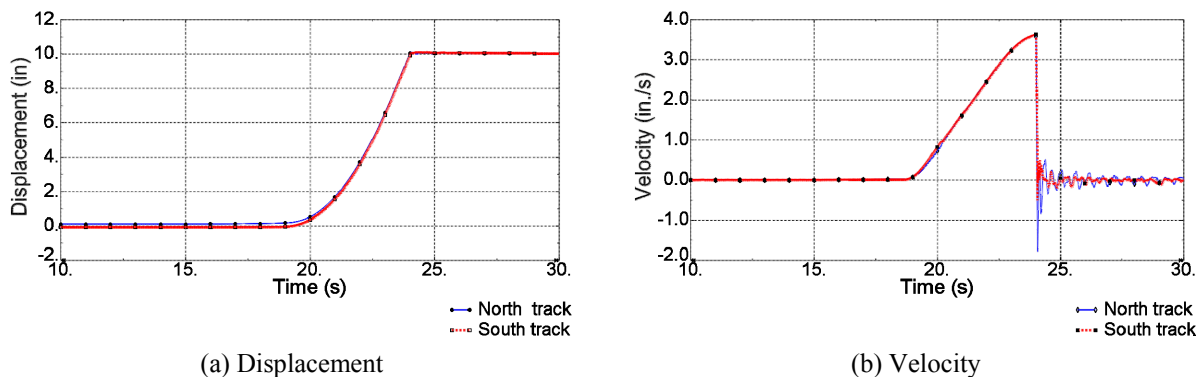


Figure 5-35. Variation of displacement and velocity of superstructure against time at each sliding track.

From the jamming of the front roller on the north railing channel, a 373-kip impact force is developed at in the direction of sliding (Figure 5-36a). The transverse restraint provided by the sliding track and the roller assembly at the front and rear ends controlled superstructure racking. As a result, a 134-kip force is developed in the direction transverse to sliding at the interface of the channel and the front roller assembly. The transverse load history is shown in Figure 5-36b.

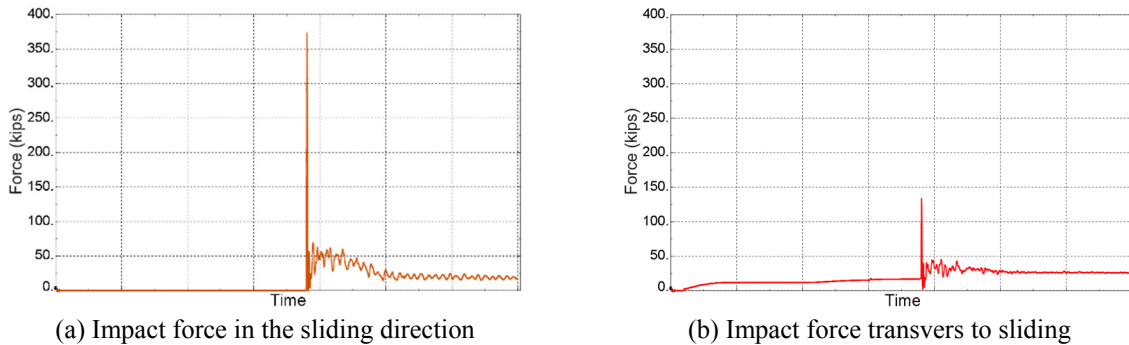


Figure 5-36. Impact forces developed at the points of contact due to jamming of the front roller on the north sliding track

Reaction forces developed as a result of the jamming. The forces in sliding and transverse directions at the supports of the temporary structure and permanent abutment are shown in Figure 5-37a and b respectively. Small magnitude reaction forces were present before sliding arising from the bridge skew. In the sliding direction, a maximum reaction force of 304 kips (33.7% of superstructure weight) is calculated at the base of the north side permanent abutment (Figure 5-37a). In the transverse direction, a maximum force of 66 kips (7.33% of superstructure weight) is calculated at the base of the south temporary structure (Figure 5-37b).

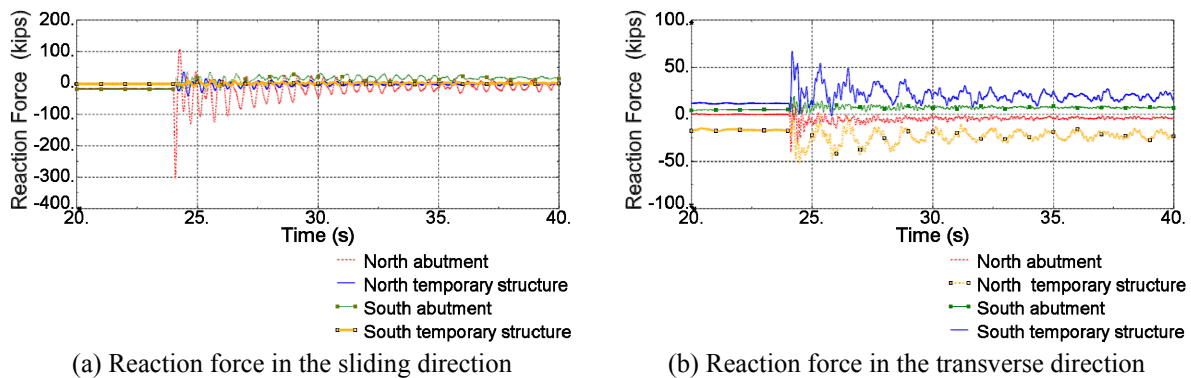


Figure 5-37. Reaction forces at the supports of temporary structure and permanent abutment

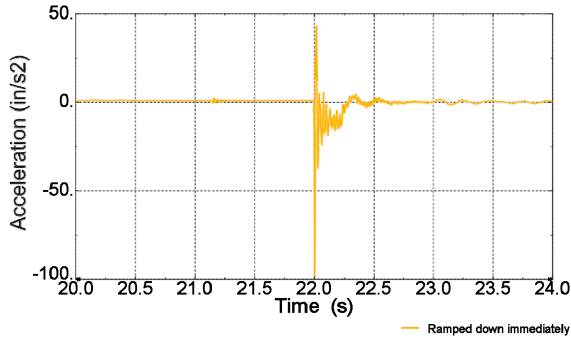
5.4.2.2 Structural Response under Actuator Piston Jerk

This section presents the analysis results due to application of actuator force profiles shown in Figure 5-34. Equal friction is specified at north and south side sliding tracks. The actuator piston motion histories and the structural response due to the actuator ramp down are presented.

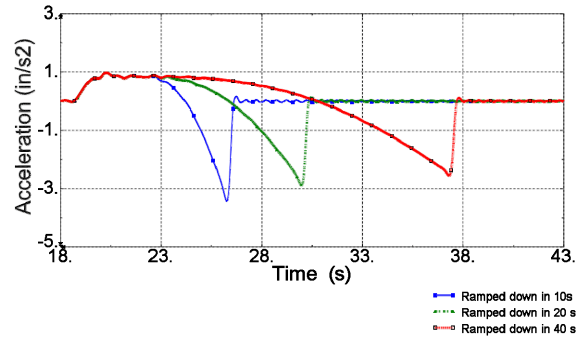
Actuator piston jerk at the onset of a pushing does not have any impact on structural response when the force magnitude is not large enough to initiate a slide. The superstructure starts accelerating at the onset of sliding. Therefore, as shown in Figure 5-34, until the onset of sliding, similar actuator force profiles are maintained. Jerk develops during the deceleration stage and impacts the sliding forces and the support reactions.

Actuator force histories are shown in Figure 5-34 and the corresponding acceleration, jerk, and velocity histories at the actuator piston and the structure connection for each simulation are shown in Figure 5-38. The following observations are derived from the analysis results:

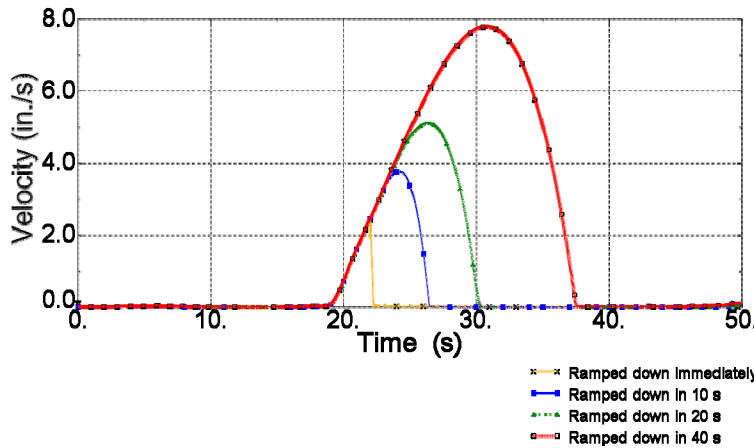
- In the first analysis case, actuator is gradually ramped up and maintained at a constant magnitude for 2 seconds. Then, the force is abruptly removed indicating a sudden ramp down. As a result, the superstructure is subjected to a maximum deceleration of 98.5 in/s^2 and the velocity is dropped to 0 in 0.2 s.
- In the second analysis case, the actuator is gradually ramped up and maintained at a constant magnitude for 2 seconds. Then, the force is gradually decreased within 10 s using a linear ramp down. In this case, the maximum deceleration is 3.4 in/s^2 . Velocity of the superstructure is dropped to 0 in 4.5 s.
- In the third analysis case, the actuator is gradually ramped up and maintained at a constant magnitude for 2 seconds. Then, the force is gradually decreased within 20 s using a linear ramp down. In this case, the maximum deceleration is 2.88 in/s^2 and the velocity is dropped to 0 in 8.5 s.
- In the fourth analysis case, the actuator is gradually ramped up and maintained at a constant magnitude for 2 seconds. Then, the force is gradually decreased within 40 s using a linear ramp down. In this case, the maximum deceleration is 2.55 in/s^2 and the velocity is dropped to 0 in 15.5 s.



(a) Acceleration for sudden ramp down



(a) Acceleration for ramp down in 10, 20, and 40 seconds



(c) Velocity

Figure 5-38. Actuator piston motion histories

Figure 5-39 shows the structural response and reaction forces developed under various actuator force profiles, which are shown in Figure 5-34. As shown in Figure 5-39, identical force responses are developed at the sliding surfaces and at the supports until the piston ramp down is started. The largest reaction at the supports of temporary structures and permanent abutments are developed when the piston force is ramped down, generating a large jerk. The largest reaction at the base of the north side permanent abutment is 14.6 kips (i.e., 1.62% of the superstructure weight).

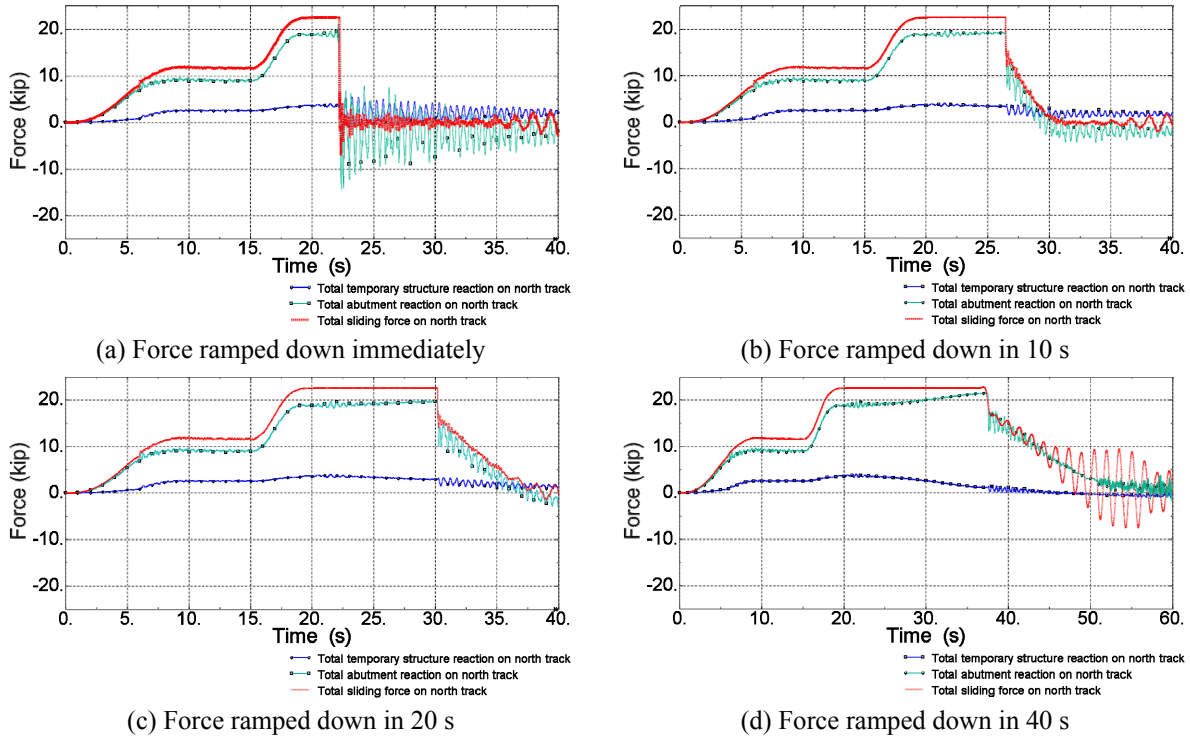


Figure 5-39. Sliding and reaction force histories

5.4.2.3 Load Transfer through Rigid Connection between Temporary Structure to Permanent Abutment

A bolted moment transfer joint connects the temporary structure with the permanent abutment. The sliding force is resisted by the temporary structure and transferred to the permanent abutment. The total sliding force and reactions at the base of the temporary structure and permanent abutment are shown in Figure 5-39. As shown in the figure, 86% to 97% of the sliding force is transferred to the permanent abutment through the connection. Total sliding force is 5% of the superstructure weight and 4.3% to 4.85% of the weight is resisted by permanent abutment while 0.7% to 0.15% of the weight is resisted by the temporary structure.

5.4.3 Summary

FE simulations of the M-100 over CN railroad bridge slide operation is performed. The primary objective of the simulations is to calculate the structural accelerations, velocities, forces from jamming of a roller, and actuator jerk. In addition, the magnitude of force transfer from temporary to the permanent substructure are calculated during these actions.

Analyses are performed under a force control procedure with discrete pushing events. In each pushing event, the superstructure moves with pauses representing the typical pushing cycles of a slide operation. For each analysis, railing girders at abutments on north and south sides are positioned at the same alignment. A constant friction of 5% is assumed between the rollers and the sliding rails. A stopping block is defined inside the sliding track on the north side to simulate the jamming of a roller during a slide event.

The following conclusions are derived based on the finite element simulation results presented in this chapter:

1. Jamming of a roller on one sliding track resulted in racking of the superstructure. The rollers used for the sliding of this particular bridge provide transverse movement restraints. Hence, forces are developed in the slide direction as well as in the direction transverse to sliding. The forces developed at the sliding track are transferred to the temporary structure and permanent substructure supports. In the sliding direction, a maximum reaction force of 304 kips (33.7% of superstructure weight) is calculated at the base of the north side permanent abutment. In the transverse direction, a maximum force of 66 kips (7.33% of superstructure weight) is calculated at the base of the south temporary structure.
2. Influence of an actuator jerk on structural response is investigated. Abrupt removal of an actuator force creates the most critical case. During such an event, a large inertia force is created on the temporary structures and transferred to permanent abutments. As a result, temporary structure and permanent abutment are subjected to a dynamic response and the maximum amplitude of support reactions developed at the base of a permanent abutment at the north track is 14.6 kips (i.e., 1.62% of the superstructure weight).

3. Various connection details are used between temporary structures and permanent substructures. For the M-100 bridge, a bolted moment transfer connection is used. Further, the temporary structure vertical supports are constructed with extended steel H-piles while the permanent abutments are concrete walls. Hence, the abutments are much stiffer than the temporary structures. As a result, 86% to 97% of the sliding force is transferred to the permanent abutment through the connection. Total sliding force is 5% of the superstructure weight and 4.3% to 4.85% of the weight is resisted by permanent abutment, while 0.7% to 0.15% of the weight is resisted by the temporary structure.

5.5 STANDARDIZING SIBC PROCEDURES

FHWA repository and DOT resources were reviewed and the various SIBC components and procedures are documented in Chapter 2. In addition, the US-131 over 3 Mile Road, M-50 over US-96, and M-100 over CN railroad SIBC projects were monitored. Successes, difficulties, and activities were documented and analyzed. Moreover, FE simulations of the US-131 over 3 Mile Road and M-100 over CN railroad were performed to calculate structural effects of the slide and investigate the sources and effects of the difficulties.

Design procedures, considerations, and limitations are formulated based on the findings from the reviewed and monitored projects as well as from FE simulations. This section presents a detailed step-by-step process to standardize bridge slide design and procedures.

5.5.1 Overview of SIBC Design

SIBC includes four major design activities encompassing the design of the replacement bridge, sliding system, actuating system, and temporary structure (Figure 5-40). The process starts with the design of a replacement bridge as if the bridge will be constructed by conventional methods. At this stage, the loads from the bridge slide are not taken into consideration. Next, a sliding system is designed and the superstructure design is checked against sliding loads, and modified if needed. Actuating system design is performed following the sliding system design. Superstructure is checked again for actuating loads. The final step is the temporary structure design under sliding loads.

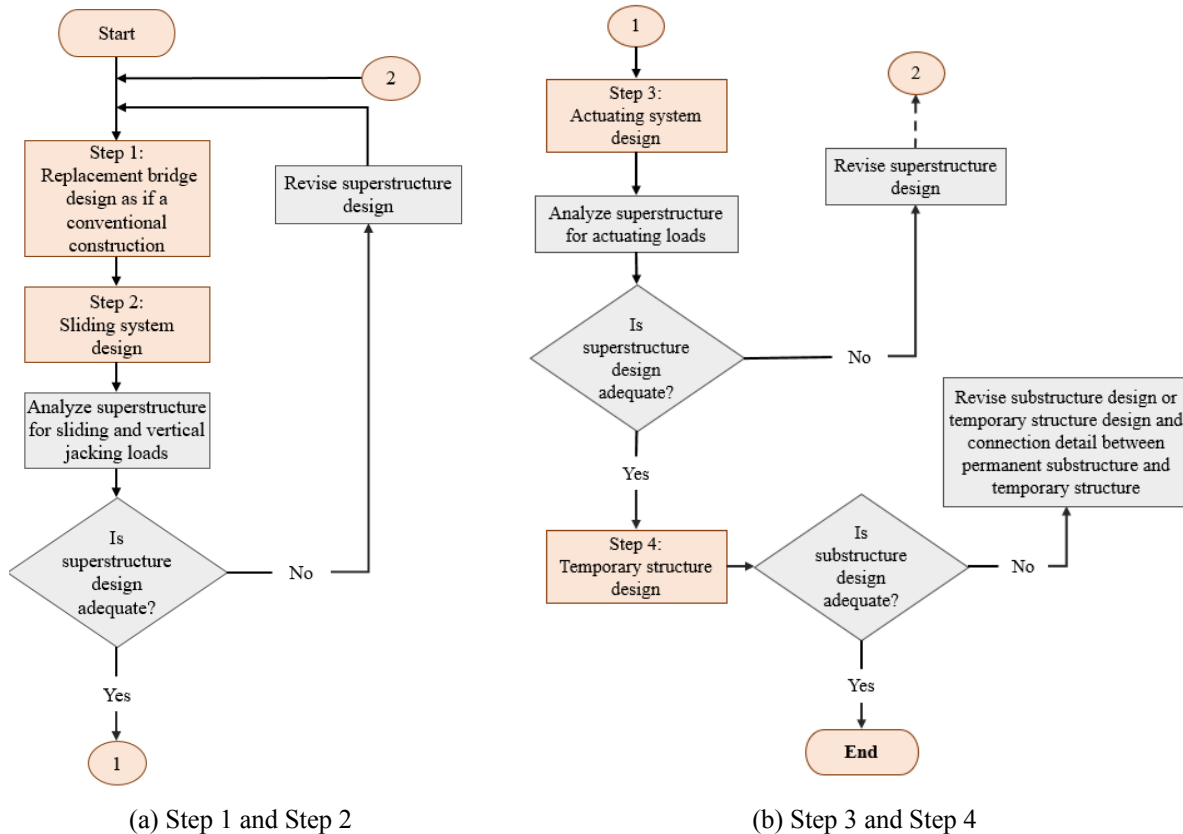


Figure 5-40. An overview of SIBC design

5.5.2 Sliding System Design Procedure

The sliding system design process is depicted in Figure 5-41, Figure 5-42, and Figure 5-43. A typical sliding mechanism can be specified using either *Teflon* or rollers. Hence, the first step in a sliding system design is the selection of a slide mechanism. Based on past project experience and numerical simulation results, it is suggested to maintain a transverse movement tolerance of, at the most, 1 in. for *Teflon* and 0.1 in. for rollers. If *Teflon* is specified, the design process depicted in Figure 5-42 is followed. For rollers, the process shown in Figure 5-43 is followed.

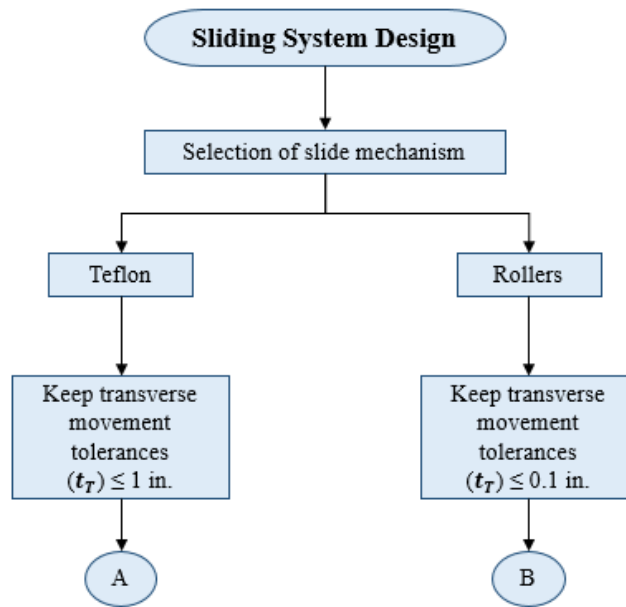


Figure 5-41. Sliding system design procedure

5.5.2.1 Sliding Shoe and Teflon Bearing Pad Design Procedure

The design procedure is shown in Figure 5-42. Weight of the superstructure is calculated after completing Design Step 1 in Figure 5-40. The number of sliding shoes and the size of a shoe need to be determined so that the bearing pressure at each shoe is maintained in between 0.5 ksi and 2 ksi. Even though bearing pressure can be calculated based on the area under the sliding shoe, it can vary based on the contact area during slide. Contact area is affected by deformations of the sliding track because of the differential stiffness of temporary structure. In previous projects, designers often used 1 ksi bearing pressure. As discussed in Aktan and Attanayake (2015), the friction coefficient decreases with increasing bearing pressure. However, for typical *Teflon* pads, the friction developed at the sliding surface with the above stated bearing pressure range is lower than the typical values used for a bridge slide design. Lubrication is often used to reduce friction between sliding surfaces. Hence, dimpled *Teflon* surfaces are recommended, as they can hold lubrication on the surface during slide.

The coefficient of friction is a function of sliding velocity. According to the data presented in Aktan and Attanayake (2015), for a velocity up to 0.1 in/s with a surface roughness of 2 micro inches and a bearing pressure range of 0.5 ksi to 2 ksi, the friction coefficient remains less than 5%. Sliding velocities of 0.07 in/s and 0.4 in/s have been recorded from past projects (Aktan and

Attanayake 2015). Force histories were not recorded during those slides that would have facilitated the calculation of friction coefficients. When designing the sliding shoe and bearings, it is recommended to assume a reasonable sliding velocity using the data presented in Aktan and Attanayake (2015). The coefficient of friction is used for the sliding force calculation and bearing design. The breakaway friction coefficient for initiating the slide is the highest. Due to the lack of field data for quantification, 10% static and 5% kinetic friction coefficients are assumed. It is recommended to use these friction coefficients until more refined data is available from future implementations. Once the bearing pressure and the sliding force is calculated, the sliding bearing is designed. If the bridge is moved on permanent bearings, the design needs to be evaluated against the permanent bearing design requirements based on the governing specifications. If the bridge is moved on temporary bearings, vertical jacking is required. It is recommended to specify the number of jacks, locations, and the capacity of each jack to minimize the differential movement of the bridge superstructure and thus, to minimize concrete cracking potential. Further, superstructure design needs to be evaluated for the vertical jacking forces and deformation tolerances.

The typical practice is to construct the replacement bridge superstructure on sliding bearings and route traffic over the new superstructure on a temporary structure while preparing the site for bridge replacement. This requires checking the bearing design against the permanent bearing design requirements. Hence, irrespective of whether the bridge is to be moved on permanent bearings or not, the sliding bearing design needs to be evaluated against the permanent bearing design requirements.

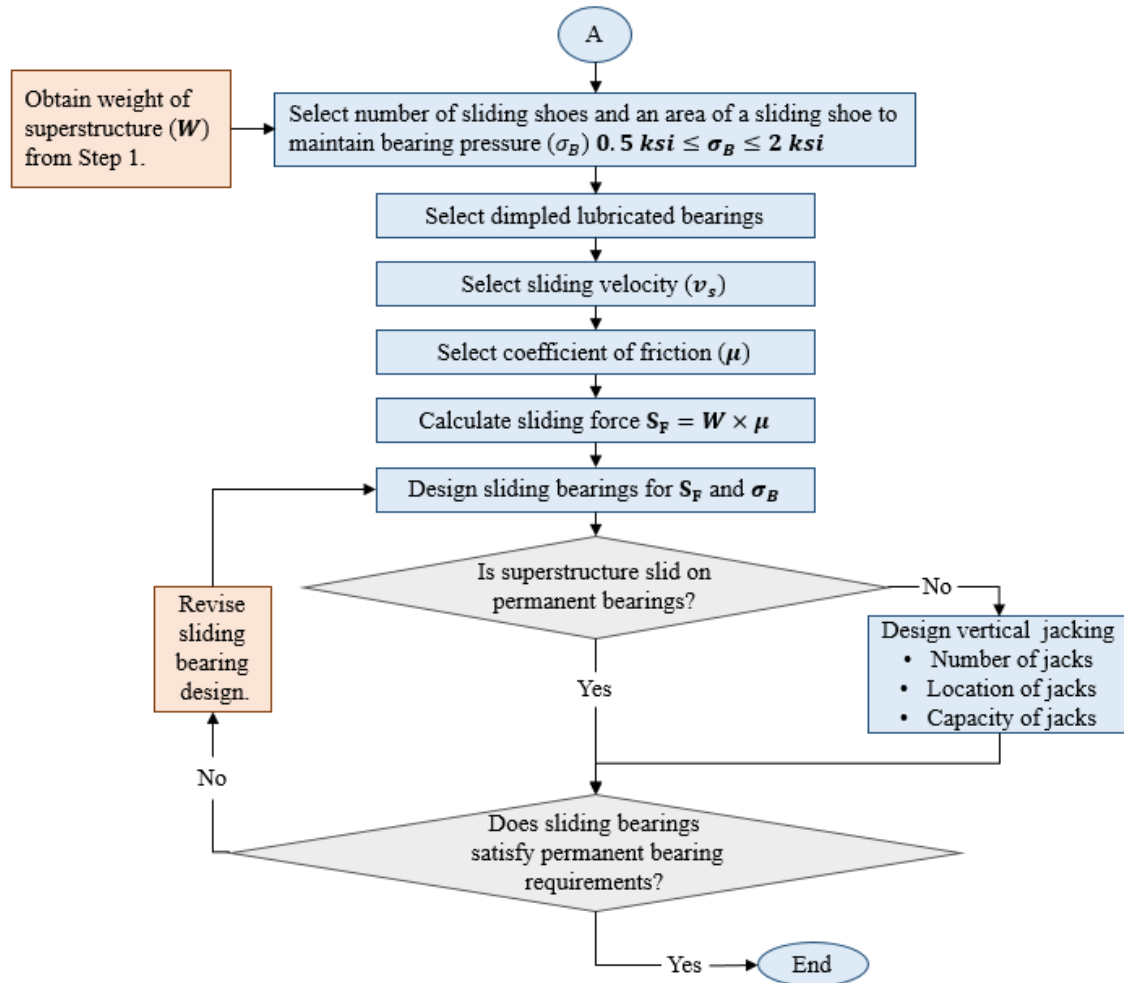


Figure 5-42. Sliding shoe and Teflon bearing pad design procedure

5.5.2.2 Design Procedure for a Sliding System with Rollers

The major steps of the design procedure are shown in Figure 5-43. The first step is to determine the number of roller assembly units needed for the slide. Here, each unit is referred to as an assembly because it consists of many rollers connected to form a chain of rollers with top and side plates (Figure 5-44). For multigirder bridges, the typical practice is to place one unit under each girder end. Once the number of units is decided, the next step is to calculate the load carried by each unit. Total weight of the bridge superstructure is acquired after completing Design Step 1, as shown in Figure 5-40. Knowing the total weight and bridge configuration, load acting on each unit can be calculated. It is reasonable to assume that the load acting on each unit is equally distributed amongst the number of rollers in contact with the slide track. As shown in Figure 5-44, only a limited number of discrete rollers in a chain is in contact with the slide track at a given

position. For example, the roller unit shown in Figure 5-44 contains 20 rollers, but only 8 of them are in contact with the track at a given position. The geometric dimension of roller units that can carry the load calculated in the previous step can be established using the technical specifications from the manufacturers/suppliers. A candidate roller assembly can then be selected based on the dimensions of the roller assembly and sliding track dimensions. Sliding track material properties required for calculations include the modulus of elasticity (E_T), Poisson's ratio (ν_T), and yield strength (f_{YT}). The next step in the design process is to acquire the design parameters from the technical specifications provided by the roller manufacturer. The design parameters are the number of rollers in contact with the track (n), radius of a single roller (R_R), contact length of a roller (L_R), and the elasticity modulus (E_R) and Poisson's ratio (ν_R) of the roller material.

The contact stress between a roller and the sliding track can be calculated with Hertz's formula (Eq. 5-6) (Hearn 1997). Using Eq. 5-6 the maximum normal stress (σ_{max}) acting on the sliding track can be calculated. Current practice is to use an allowable stress design with a safety factor of 2. If the allowable stress limits are not satisfied, the designer has two options – select a roller assembly for reevaluation or increase the number of roller units selected to support the bridge superstructure. Once the allowable stress limits are satisfied, the sliding track deflection is calculated based on the support structure configuration and the loads. Rollers are installed just before the bridge slide and removed following the slide. As a result, vertical jacking is inevitable, and requires calculating the number, location, and capacity of these jacks. In order to maintain superstructure alignment during slide and to control “racking”, guide rollers need to be incorporated into the roller units located under the fascia girders. A coefficient of friction of 5% is used for the slide force calculation.

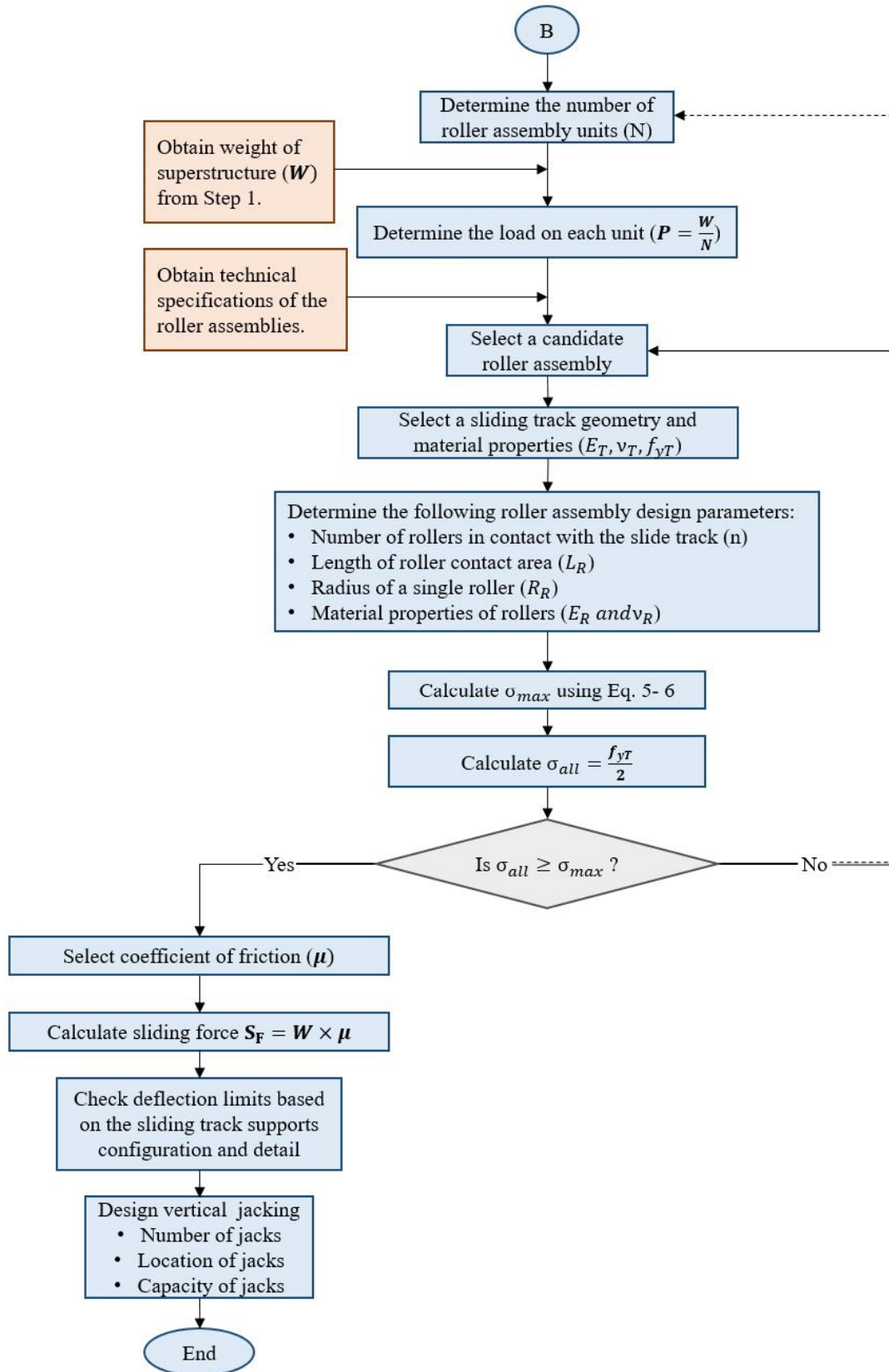
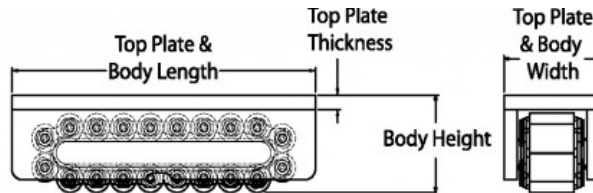


Figure 5-43. Design procedure for a sliding mechanism with rollers



(a) A roller assembly unit used for bridge slide



(b) Number of rollers in contact with a sliding track and contact width of a roller

Figure 5-44. A roller assembly unit used for bridge slide (Source: Hilman 2016)

$$\sigma_{max} = 0.591 \sqrt{\frac{P}{R_R L R E'}} \quad (5-6)$$

where,

$$E' = \frac{1-\nu_R^2}{E_R} + \frac{1-\nu_T^2}{E_T} \quad (5-7)$$

When needed, the width of the roller contact area can be calculated using the following equation:

$$b = 2.152 \sqrt{\frac{P E' R_R}{L_R}} \quad (5-8)$$

Hertz's formula shown in Eq. 5-6 incorporates several simplified assumptions (Stachowiak and Batchelor 2014). Assuming a frictionless surface, the maximum shear stress (τ_{max}) is equal to one third of σ_{max} and is located at a distance of $0.393b$ below the sliding surface of the track. When the bridge superstructure is supported on rollers, friction is present at the sliding track surface reacting to the sliding or the tendency to slide. When friction is present and other assumptions are violated, the stress state becomes highly complicated. However, the stress calculated using Hertz's formula can still be used for design. As stated by Hearn (1997), use of Hertz's formula is justified under static or very low rolling operations where failure normally arises as a result of excessive plastic flow which produces indentation to the surface. Further, when the rollers and the sliding track are reused in slide projects, surface fatigue on the contact surface needs to be evaluated. Assessing the validity of these design assumptions through instrumentation and monitoring during future implementations is needed to develop standard designs and procedures for bridge slides.

5.5.3 Actuating System Design Procedure

Design procedure is shown in Figure 5-45 and Figure 5-46. As the first step, a hydraulic operation system is specified. Actuating force capacity is a function of the sliding force and bridge superstructure acceleration and weight. Sliding force is calculated during the sliding system design. Superstructure weight has been previously calculated. Superstructure acceleration data is not widely available. The monitoring conducted as part of this project recorded a maximum of 0.2%g acceleration in the sliding direction with the slide performed using rollers. Since the acceleration data for a slide using slide bearings is not available, use of 0.2%g as peak superstructure acceleration is reasonable. In order to have an adequate capacity to initiate the slide, actuator needs to have 25% additional capacity than the calculated required force. A maximum actuator capacity should be limited to 150% of the required capacity in order to have better control during a slide. Once the actuator force capacity is determined, the next step is to specify a suitable stroke length. Different stroke lengths ranging from 2 in. to 48 in. have been used during past projects. Having a short stroke length slows down sliding of a bridge to its final alignment due to frequent resets to the hydraulic actuator positions. Long strokes require additional alignment controls to reduce the possibility of rocking and jamming. Specifying a stroke length that is in between 20 in. and 40 in. is suggested. With limited slide monitoring and actuator control, it is suggested to specify a stroke length closer to the lower bound. With a longer stroke length, it is recommended to perform the slide using advanced slide monitoring systems such as servo controlled hydraulic actuators. Next, the hydraulic oil reservoir volume and pump capacity is specified based on the required force and stroke length. A sufficiently large reservoir capacity needs to be maintained to control hydraulic oil temperature.

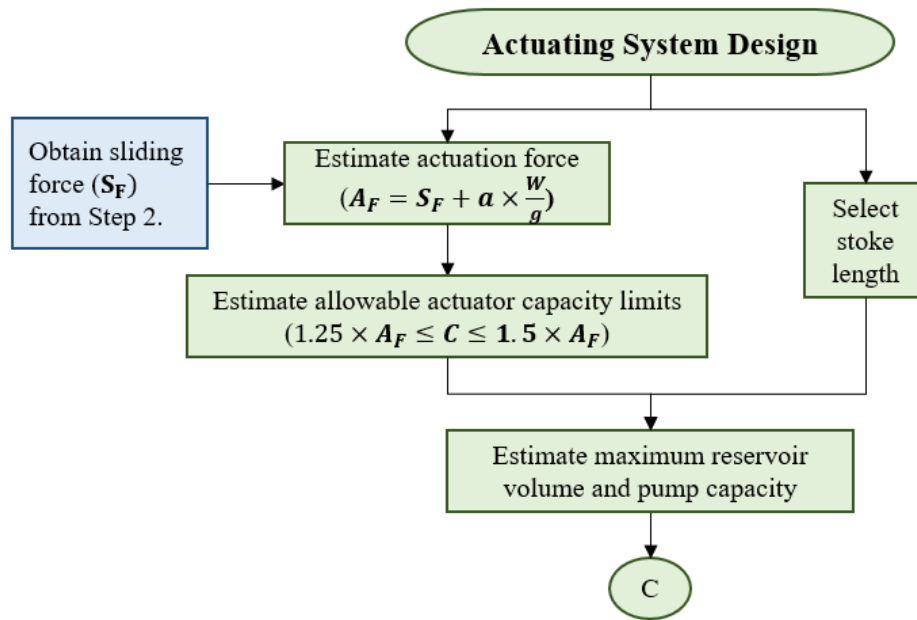


Figure 5-45. Hydraulic operation system design procedure

Actuating mechanism selection procedure is described in Figure 5-46. The use of a hydraulic actuator with pulling and pushing capabilities, or a prestressing jack with pulling capability are the two alternatives suggested.

Hydraulic actuator requires having reactive and pushing connections at the sliding track and the superstructure, respectively. An actuator casing saddle with holes and pins, or ears, are two connection types used in many completed SIBC projects as reactive connections. It is important to provide a sufficient number of connection points with appropriate tolerances in both connection types to reduce delays while retracting the actuator during bridge slide. A pushing connection is the connection between the actuator and superstructure where all the actuating loads are transferred to the superstructure. A swivel connection needs to be used for the pushing connection in order to assure load transfer alignment to the sliding direction.

A stationary reaction frame is needed when prestressing jacks are used for pulling or pushing a bridge. Depending on site conditions or the selected temporary and permanent structure types, temporary structure, permanent abutment wingwalls, backwalls, or even the superstructure itself can be used as a reaction frame. High strength steel tendons are used with prestressing jacks.

Tendon elongation and relaxation need to be properly accounted for in order to minimize jerky movements and racking of the superstructure.

Servo controlled and pressure regulated mechanisms are explained in Chapter 2. It is strongly recommended to utilize a servo controlled mechanism to minimize the potential for jamming and superstructure racking due to the unequal friction on sliding surfaces. This is especially important with unguided sliding systems.

Use of prestressing jacks create additional risks because of tendon elongation and relaxation. Manual monitoring may not be sufficient to control the movement. Therefore, a servo controlled mechanism with synchronized and computerized monitoring and control capabilities is recommended.

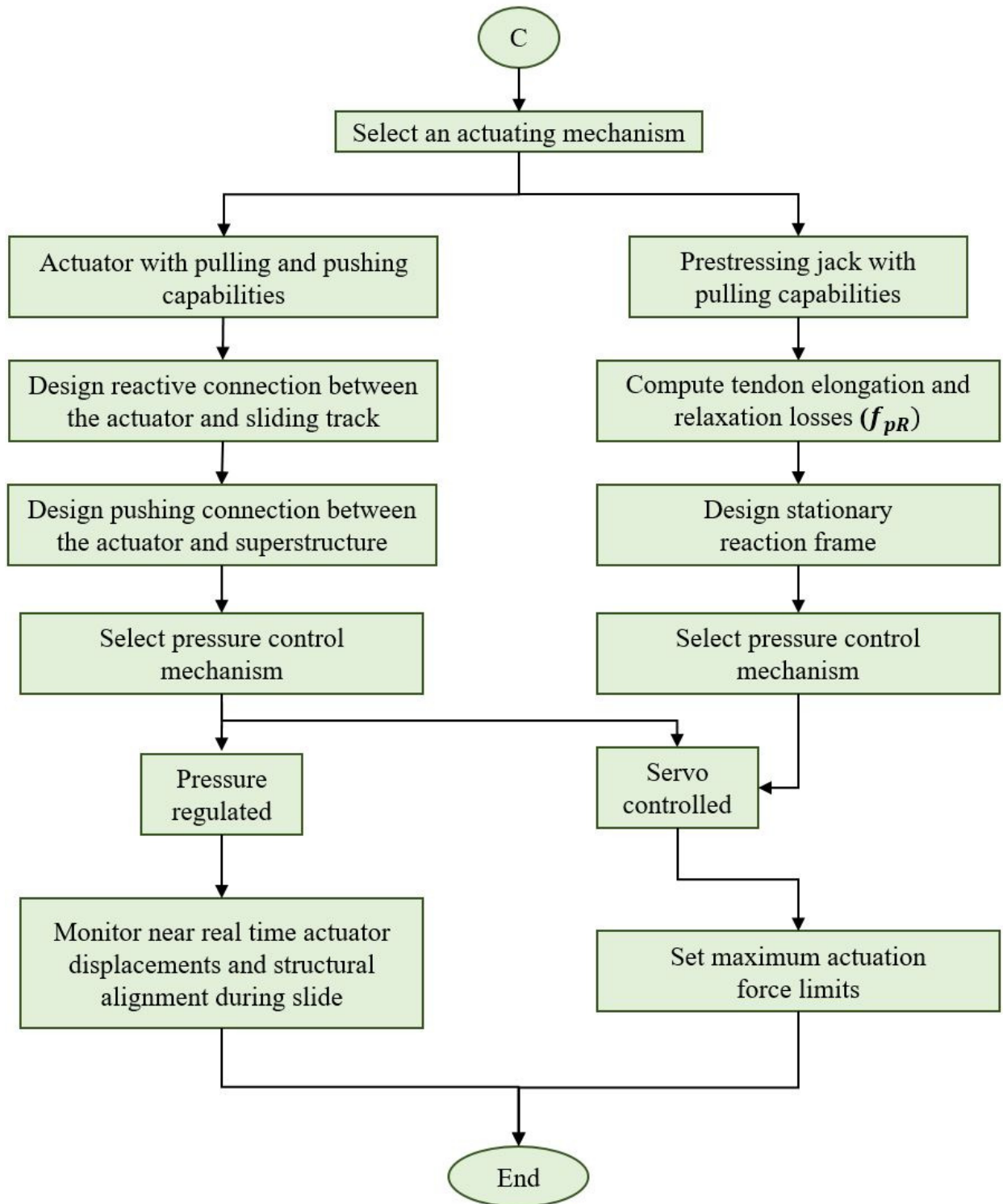


Figure 5-46. Actuating mechanism design procedure

5.5.4 Summary

Standard procedures for the design and component selection of lateral bridge slide activities are described in this section. Flowcharts describe significant design considerations and compatible components for lateral bridge slide.

The following conclusions are derived based on the developed standard procedures presented in this chapter:

1. A replacement bridge can be designed as if it is to be constructed conventionally when SIBC is specified for the project. Even though SIBC will not require significant changes to the bridge design, superstructure and substructure should be checked under SIBC loads.
2. A sliding system design includes a slide mechanism selection with options for *Teflon* with steel sliding shoes or rollers with sliding tracks. Design of the vertical jacking components are also included in a sliding system if temporary sliding bearings or rollers are used as a sliding mechanism. Use of *Teflon* requires the design of neoprene bearings with a *Teflon* surface and sliding shoes, while rollers are selected from manufactured products having the required capacity. Transverse movement tolerances, bearing pressure under sliding shoes, sliding velocity, coefficient of friction, and sliding force are estimated at this stage based on the specified and designed components.
3. Actuating system design includes a hydraulic operation system and an actuating mechanism selection including options of hydraulic actuators and prestressing jacks. A hydraulic operation system includes the design of stroke length, estimating actuating force and actuator capacity based on the sliding force calculated in the sliding system design, hydraulic pump reservoir volume, and pump capacity.
4. Hydraulic cylinders require reactive and pushing connections which may have a significant impact on slide quality and speed. On the other hand, prestressing jacks require a stationary reaction frame design.
5. Servo controlled and pressure regulated control mechanisms are available. Even though force control mechanism can be specified with the hydraulic actuators, servo controlled pressure regulated control is strongly recommended to improve the quality of monitoring and to reduce the problems created from unequal friction development on sliding tracks.

6 SUMMARY, CONCLUSIONS, AND RECOMMENDATIONS

6.1 SUMMARY AND CONCLUSIONS

The Michigan Department of Transportation (MDOT) has implemented several accelerated bridge construction (ABC) projects. The first phase of the project on ABC, *Improving Bridges with Prefabricated Precast Concrete Systems* (Aktan and Attanayake 2013), developed recommendations towards standardizing prefabricated bridge elements and systems (PBES) by classifying elements, systems, and connections for Michigan. The project also developed a multi-criteria decision-support framework and the associated software platform (Mi-ABCD) for comparing ABC and conventional construction (CC) alternatives for a specific site. At present, MDOT uses Mi-ABCD during the scoping process to evaluate bridge projects for ABC potential. Even though ABC methods include PBES, slide-in bridge construction (SIBC), and self-propelled modular transporter (SPMT) moves, the current version of Mi-ABCD considers only PBES as the ABC method. The next phase of the project expanded the framework to include SIBC and SPMT moves.

The current project was initiated to (i) develop a new version of the Mi-ABCD support tool to include bridge slides and SPMT moves, along with PBES and CC; (ii) develop methods to increase user awareness of ABC projects and construct models for quantifying the economic impact of bridge construction on surrounding communities and businesses; (iii) develop a standardization process for replacing a bridge using lateral slide technique; and (iv) develop implementation recommendations from the results of the project.

6.1.1 Mi-ABCD Support Tool

The Mi-ABCD framework presented in Aktan and Attanayake (2013) was expanded to incorporate SIBC and SPMT move parameters. The updated framework is presented in the report titled *Research on Evaluation and Standardization of Accelerated Bridge Construction Techniques* (Aktan and Attanayake 2015). During this project phase, the updated framework was implemented in a Mi-ABCD platform, enabling it to be used during the scoping process to evaluate bridge projects and identify the most suitable construction alternative among CC, PBES, SIBC, and SPMT move.

The recommended use of Mi-ABCD tool is as follows:

- Step 1: The scoping engineer or the project manager, as the *Advanced User*, first completes the datasheets for *Project Details*, *Site-Specific Data*, *Traffic Data*, and *Cost Data*. *Advanced User* can assign preference ratings, perform analysis, and view results. Then, the file is saved with the project ID and the date.
- Step 2: As needed, the file is then routed sequentially to project engineers designated as *Basic User(s)* for their entry of preference ratings and associated comments.
- Step 3: For each *Basic User* to access the *Preference Ratings* datasheet as a “New User,” the current user must *Logout* after completing preference ratings, performing analysis, and viewing the results.
- Step 4: Finally, the Statewide Bridge Alignment Team/Bridge Committee or Project Team reviews data, preference ratings, and the results to deliberate and determine the suitability of ABC in comparison to CC. If needed, the *Advanced User* is allowed to *Delete All Ratings and Comments* and input a new set of ratings that may have developed during the deliberation process. If ABC is preferred, the committee would then recommend the bridge be programmed for SIBC, PBES or SPMT. The Mi-ABCD with data and output is retained as justification to the ABC decision.

6.1.2 Economic Impact Analysis

Economic impact and safety within construction zones are two major parameters considered when evaluating bridge construction methods for a specific site. ABC methods are implemented over CC techniques to reduce roadway closure duration, which is also known as the mobility impact time. Site complexities, time constraints, and perceived risks increase ABC project cost by 6% to 21% over that of CC. Nonetheless, the reduction in mobility impact time and the improved durability of the new bridge generate benefits from the reduced maintenance of traffic cost, reduced lifecycle cost, and reduced economic impact on surrounding communities and businesses. Traditionally, the savings in user cost from reduced mobility impact time is the justification for the additional cost of accelerated construction implementations. In addition to user costs, there are other costs of bridge projects to businesses and communities. Impact on a business is primarily evaluated in terms of business revenue change. The impact on communities include disruption to mobility and adverse effects on the environment.

A model was developed to quantify economic impact on surrounding communities and businesses from a bridge project during the construction duration. Additional impacts during other lifecycle events, such as Capital Preventive Maintenance (CPM) and Capital Scheduled Maintenance (CSM), are not included. Economic impact on surrounding communities and businesses was calculated for the M-100 over Canadian National (CN) railroad bridge replacement project in Potterville, Michigan. SIBC is compared to bridge replacement using CC. The economic impact analysis yielded the following results:

- The economic impact on surrounding communities by SIBC and CC are calculated as \$731,083 and \$5,242,411, respectively. Accordingly, the impact on communities from CC is 7.2 times greater than the impact from SIBC. The significant contribution comes from the user cost. The percentage of user cost in economic impact on surrounding communities with SIBC and CC are 99% and 89%, respectively. Hence, environmental cost can be excluded from economic impact on surrounding communities in rural networks. However, it is important to incorporate those effects in the economic impact analysis for more complex road networks (such as high population urban areas) when traffic congestion is often observed.
- The significant parameters affecting economic impact on surrounding communities through user cost from passenger vehicles and environmental cost are the duration of construction activities within the work zone (N), the mobility impact time (T_M), the length of detour for passenger vehicles (L_{Dpv}), the length of detour for trucks (L_{Dt}), the speed correction factor (SCF), and truck weight.
- The economic impact on surrounding businesses by SIBC and CC are \$50,313 and \$813,614, respectively. Hence, the economic impact on surrounding businesses by CC is about 16 times greater than the impact by SIBC. User cost and business revenue change contribute to economic impact on surrounding businesses. Similar to economic impact on surrounding communities, user cost plays an influential part on the economic impact on surrounding businesses with a percentage of 87% for SIBC. However, business revenue change, contributing 74% of the total, increases when mobility impact time is extended using CC. Hence, both parameters are necessary to account for impact to businesses due to bridge construction.

- The significant parameters affecting economic impact on surrounding businesses through user cost from trucks and business revenue change are the total duration of construction activities within the work zone (N), the mobility impact time (T_M), the length of detour for trucks (L_{Dt}), the change in the number of customers (ΔC), average expenditure per household (AE), mobility impact time (T_M), number of households without direct access (HWA) during mobility impact time, percent of households without direct access who are averting the area influenced by the project (P), and the frequency of patronizing a specific business (F).
- The overall economic impact due to using CC is 7.8 times greater than that using SIBC.

6.1.3 Standardizing SIBC Design and Operations

SIBC can allow maintaining traffic on the existing bridge during construction of a new superstructure parallel to the in-service bridge. Traffic can be shifted and maintained on the new superstructure during bridge demolition and substructure construction. Typically, the mobility impact duration of SIBC is about 24 to 48 hours. SIBC activities include (i) a temporary structure designed and constructed to support a new superstructure during the construction and lateral slide, (ii) a sliding system to provide interaction surfaces and a path during slide, and (iii) an actuating system to provide forces for initiating and maintaining bridge slide.

Each SIBC implementation has, so far, been unique. Unknowns include slide properties contributing to friction between surfaces, pushing and pulling force levels, and monitoring and controlling the force levels. The purpose of standardization is to develop a repeatable set of procedures for SIBC. Another aspect of standardization is developing an understanding of the structural system response during slide activities. This requires documentation of various practices, monitoring structural response in order to quantify forces developed in the system and to calibrate numerical models for further analysis, and simulation of slide activities.

Twenty-eight (28) SIBC projects were reviewed and information was compiled on SIBC components and design parameters, temporary structure design, sequence of operations, constructability challenges, scoping parameters, foundation types, and cost. In addition, SIBC monitoring activities, technologies used for monitoring, and the findings were documented. However, the monitoring objectives were primarily focused on successfully completing the project

in time rather than collecting data for verifying the design assumptions and quantifying the forces developed during sliding activities.

A remote monitoring system with accelerometers was developed and implemented during the M-100 over CN railroad bridge slide. The following conclusions are derived based on the monitoring and data analysis results:

- Acceleration monitoring of bridge slide was sufficient for quantifying transverse force and differential friction between the tracks. Measuring acceleration in two directions at only one location was also sufficient for calculating friction differences between sliding tracks. However, actuating forces should also be monitored to verify sliding forces.
- Large difference in friction coefficient was calculated between tracks during the first push cycle. This generated a large difference in the net sliding force between tracks. As a result, a large transverse force developed. Slide difficulties at the start can create challenging situations for the following push cycles. It is important to perform test slides to identify and minimize friction differences between sliding tracks.
- Net sliding forces were calculated for the first push cycle as 0.65% of the weight in slide direction on one track, and 0.44% of the weight in reverse direction on the other track. Actuation force overcame friction force on one track resulting in positive net sliding forces. The actuation force was less than the friction force on the other track. So the motion started on one track only. This was a result of equal actuation forces resisted by unequal friction forces. The differential friction coefficients between the tracks were calculated as 1% and 0.63% of the weight.
- A larger difference in friction coefficient between tracks results in developing larger transverse forces. A certain level of difference between friction forces is unavoidable. Sliding tracks may be shielded until the start of the slide activity to control the friction and to minimize transverse force development. Another approach could be to initiate a small amplitude back and forth movement (dither movement) of the superstructure to eliminate the static to dynamic friction coefficient variation.

The M-100 over CN railroad bridge slide was used as the prototype for FE slide simulation. When rollers are used, most critical forces are developed in the system if the rollers jam on one of the

railing girders. Hence, sliding operation of the M-100 bridge was simulated and roller jamming on the railing girder at the north abutment was modelled. In addition, the impact of actuator jerk during the ramp down of a push event and the load transfer was evaluated at the connection between the temporary structure and permanent abutments. The following conclusions are derived based on the finite element simulation results:

- Roller jamming on one sliding track resulted in racking of the superstructure. The rollers of this particular bridge provide transverse movement restraints. Hence, forces are developed in the slide direction as well as in the direction transverse to sliding. The forces developed at the sliding track are transferred to the temporary structure and the permanent substructure supports. In the sliding direction, a maximum reaction force of 304 kips (33.7% of superstructure weight) is calculated at the base of the north side permanent abutment. In the transverse direction, a maximum force of 66 kips (7.33% of superstructure weight) is calculated at the base of the south temporary structure.
- The influence of actuator jerk on structural response is investigated. Abrupt removal of actuator force creates the most critical case. During such an event, large inertia forces are created on the temporary structure and transferred to permanent abutments. As a result, the temporary structure and permanent abutment are subjected to a dynamic force. The maximum amplitude of support reactions developed at the base of the permanent abutment at the north track is 14.6 kips (i.e., 1.62% of the superstructure weight).
- Various connections are designed between temporary and permanent substructures. A bolted moment transfer connection was designed for the M-100 bridge. Further, the temporary structure vertical supports are constructed with extended steel H-piles, while the permanent abutments are concrete walls. Hence, the abutments are stiffer than the temporary structures. As a result, 86% to 97% of the sliding force is transferred to the permanent abutment through the connection. The total sliding force is 5% of the superstructure weight; 4.3% to 4.85% of the weight is resisted by the permanent abutment while 0.7% to 0.15% of the weight is resisted by the temporary structure.

After reviewing 28 SIBC project activities, monitoring SIBC activities in Michigan, monitoring acceleration response during bridge slide using rollers, and performing FE simulation of SIBC, this report is the first step towards standardization. This report presents a set of flowcharts

depicting an overview of a SIBC design, a sliding system design with *Teflon* pads and rollers, and an actuating system design.

6.2 RECOMMENDATIONS

The recommendations developed in this study are specific to (1) the implementation of Mi-ABCD, (2) economic impact analysis, and (3) the standardization of SIBC. As a result, the following actions are advised:

1. Mi-ABCD is developed as a tool to compare bridge construction alternatives for a given site. In order to help with the implementation, hands-on training workshops will be useful. Further, an additional lite version can be developed for network level analysis.
2. A model is developed for the quantification of economic impact on surrounding communities and businesses from a bridge construction project. This model can be used for network level or project level scoping with the available data and posted speed limits. The model can also be used as a post-construction analysis tool. In this case, historical data and site-specific data need to be collected. Data needs for post-construction analysis are: volume of passenger vehicle and truck traffic to be detoured (V_{pv} and V_T), work zone speed (S_a), normal speed of the roadway (S_n), accident rate per passenger vehicle-mile and truck-mile due to work zone (A_{apv} and A_{at}), normal accident rate for passenger vehicles and trucks (A_{npv} and A_{nt}), and average cost per accident. Data collection methods can be i) traffic count devices, ii) speed measurement devices, and iii) historical accident and their associated cost records. Depending on the complexity of the road network travel demand, models can be employed to capture network-based impact. Accurate numbers for the percent of households without direct access who are avoiding the area influenced by the project (P) and the frequency of patronizing a specific business (F) can be calculated through the surveys included in Appendix C. In that respect, data collection tools can be upgraded from surveys to automated surveys utilizing mobile devices. Aggregate unit daily cost for economic impact on surrounding communities and businesses can be developed depending on the complexity of the road network if a large sample of case studies for statistical accuracy is achieved with the use of the model developed in this research.
3. Monitoring needs to be incorporated into project special provisions, which will provide data for understanding structural response and the quantification of forces. This will help reduce

the uncertainty and risks of implementing SIBC projects. Additional work is needed to develop a comprehensive instrumentation plan for single and multi-span bridges by considering potential constraints for monitoring, data analysis procedures, and the implementation of outcome to standardization of SIBC.

4. A set of flowcharts depicting an overview of the SIBC design, sliding system design with *Teflon* pads and rollers, and actuating system design is presented. The flowcharts can be used as a guide during design submittal development and design review. Effective implementation of the proposed procedures requires developing design examples and conducting workshops for bridge contractors.
5. The project so far dealt with PBES and SIBC. It is important to develop a project towards standardizing SPMT move.

7 REFERENCES

- AAA (2015). "Your Driving Costs", *American Automobile Association (AAA)*, <<http://exchange.aaa.com/automobiles-travel/automobiles/driving-costs/#.Vov0H8YrK70>> (January 5, 2016)
- Aktan H. and Attanayake U. (2015). *Research on Evaluation and Standardization of Accelerated Bridge Construction Techniques*, Report: MDOT RC-1618A, Michigan Department of Transportation, Lansing, MI.
- Aktan, H. and Attanayake, U. (2013). *Improving Bridges with Prefabricated Precast Concrete Systems*, Report: MDOT RC-1602, Michigan Department of Transportation, Lansing, MI.
- Aktan, H., Attanayake, U., and Mohammed, A. W. (2014). *Michigan Department of Transportation Bridge Slide Showcase*, Report: MDOT RC-1618B, Michigan Department of Transportation, Lansing, MI.
- Allouche, E. and Gilchrist, A. (2004). "Quantification of Social Costs Associated with Construction Projects: State-of-the-Art Review." *Tunneling and Underground Space Technology*, 20, 89-104.
- American Association of State Highway Transportation Officials. *AASHTO LRFD Bridge Design Specifications, Customary U.S. Units*. Washington, DC: American Association of State Highway and Transportation Officials, 2014.
- Anderson, W. V. and Trenkler, F. (1991). "Continuous Bridge Slides Laterally into Final Position," *International Association of Bridge and Structural Engineering Report (IABSE)*.
- ARE (2010). *External Cost of Transport in Switzerland, Swiss Federal Office of Spatial Development-2014 Revision*, Federal Office for Spatial Development (ARE), Bern, Switzerland.
- Arens, M. and Jaynes, B. (2012). Utah Lateral Bridge Slide Experience.
- ATRI (2014). *An Analysis of the Operational Costs of Trucking- 2014 Update*, American Transportation Research Institute (ATRI), Arlington, VA.
- Barth, M. and Boriboonsomsin, K. (2010). *Traffic Congestion and Greenhouse Gases*, Transportation Research Board (TRB), Washington, DC.
- Bein, P. (1997). *Monetization of Environmental Impacts of Roads*, Ministry of Transportation and Highways, Vancouver, British Columbia, Canada.
- Buflco, G., Galante, F., Pariota, L., Russo Spena, M., and Del Gais, P. (2014). "Data Collection for Traffic and Drivers' Behavior Studies: A Large Scale Survey", *Procedia-Social and Behavioral Sciences*, Vol 111, pp 721-730.
- CALTRANS (2011). *Community Impact Assessment, Standard Environmental Reference Environmental Handbook Volume 4*, California Department of Transportation, Sacramento, CA.

Cohen, A., Anderson, R., Ostro, B., Dev Pandey, K., Krzyzanowski, M., Künzli, N., Gutschmidt, K., Pope, A., Romieu, I., Samet, J., and Smith, K. (2005). “The Global Burden of Disease Due to Outdoor Air Pollution”, *Journal of Toxicology and Environmental Health, Part A*, 68:13-14, pp.1301-1307.

Craig, L., Krewski, D., Shortreed, J., and Samet, J. (2005). “Strategies for Clean Air and Health”, *AIRNET Annual Conference*, Rome, Italy, November 5-7.

Culmo, M.P. (2011). *Accelerated bridge construction – Experience in design, fabrication and erection of prefabricated bridge elements and systems*, Report FHWA-HIF-12-013, Federal Highway Administration (FHWA), McLean, VA.

De Solminihaç, H. and Harrison R. (1993). “Analyzing Effects of Highway Construction on Businesses. *Transportation Research Record*, Vol 1395, pp 137-143.

Delucci M. (2000) “Environmental Externalities of Motor Vehicle Use in the US” *Journal of Transport Economic and Policy*, May 2000, Vol 34, pp 135-168.

Delucci M. and McCubbin D. (2010). “External Costs of Transportation in the US”, *Handbook of Transportation Studies*, Edward Elgar Publishing, MA, USA, pp 341-368.

Delucci, M., Murphy, J., McCubbin, D., and Kim, H. (1998). *The Cost of Crop Damage Caused by Ozone Air Pollution from Motor Vehicles*, Report: UCD-ITS-RR-96-03(12), University of Davis Institute of Transportation Studies, Davis, CA.

Delucci, M., Murphy, J., McCubbin, D., and Kim, H. (1996). *The Cost of Reduced Visibility due to Particulate Air Pollution from Motor Vehicles*, Report: UCD-ITS-RR-96-03(13), University of Davis Institute of Transportation Studies, Davis, CA.

Dobmeier, J. (2014). Slide in Bridge Construction from Engineer/Designer Perspective.

EPA (2016). “The Social Cost of Carbon”, *Environmental Protection Agency (EPA)*, <<https://www3.epa.gov/climatechange/EPAactivities/economics/scc.html>> (February 14, 2016)

EPA (2015). *Inventory of US Greenhouse Gas Emissions and Sinks: 1990-2013*, Report: EPA 430-15-004, Environmental Protection Agency (EPA), Washington, DC.

EPA (2014). “Greenhouse Gas Emissions from a Typical Passenger Car”, *Environmental Protection Agency (EPA)*, < <https://www.epa.gov/greenvehicles/greenhouse-gas-emissions-typical-passenger-vehicle-0> >, (April 23, 2016)

EPA (2013). “Understanding Global Warming Potentials”, *Environmental Protection Agency (EPA)*, < <https://www3.epa.gov/climatechange/ghgemissions/gwps.html> > (February 14, 2016)

EPA (2011). *Greenhouse Gas Emissions Standards and Fuel Efficiency Standards for Medium- and Heavy-Duty Engines and Vehicles; Final Rule US DOT/EPA*, Environmental Protection Agency (EPA), Washington, DC.

EPA (2008a). *Average in Use Emissions from Heavy Duty Trucks*, Report: EPA 420-F-08-027, Environmental Protection Agency (EPA) Washington DC.

EPA (2008b). *Average Annual Emissions and Fuel Consumption for Gasoline-Fueled Passenger Cars and Light Trucks*, Report: EPA 420-F-08-024, Environmental Protection Agency (EPA) Washington DC.

EPA (2001). *Final Facility Specific Speed Correction Factors*, Report: EPA 420-R-01-060, Environmental Protection Agency (EPA), Washington DC.

Ferguson A. (2012). *Qualitative Evaluation of Transportation Construction Related Social Costs and Their Impacts on Local Community*, Master's Thesis, University of Texas, Arlington, TX.

FHWA. (2015a). "Accelerated Bridge Construction (ABC) Project Exchange." *Bridge Collaboration Portal, Federal Highway Administration (FHWA)*, < <http://utcdb.fiu.edu/> > (April 2016)

FHWA (2015b). "Work Zone Road User Costs- Concepts and Applications", *Federal Highway Administration* FHWA <<http://ops.fhwa.dot.gov/wz/resources/publications/fhwahop12005/sec2.htm>> (January 5, 2016)

FHWA (2014a), *Crash Modification Factors in Practice*, Report: FHWA-SA-13-015, Federal Highway Administration (FHWA), Washington, DC.

FHWA (2014b). "Slide in Bridge Construction (SIBC) from the Engineer/Designer Perspective", Webinar, April 3.

FHWA (2014c). *Slide in Bridge Construction, Case Study*. Report: FHWA-HIF-13-057. 10, Federal Highway Administration (FHWA), Washington, DC.

FHWA (2013a). "Highway Statistics 2013", *Federal Highway Administration (FHWA)*, <<http://www.fhwa.dot.gov/policyinformation/statistics/2013/> > (April 4, 2016)

FHWA. (2013b). *Slide-In Bridge Construction Implementation Guide: Planning and Executing Projects with the Lateral Slide Method*, Final Report: F-ST99 (232), Office of Asset Management, Federal Highway Administration (FHWA), Washington, D.C.

FHWA (1998). *Lifecycle Cost Analysis in Pavement Design*, Report: FHWA-SA-98-079, Federal Highway Administration (FHWA), Washington, DC.

FHWA (1997). "Federal Highway Summary Report, Other Highway-Related Costs", *Federal Highway Administration (FHWA)*, < <https://www.fhwa.dot.gov/policy/hcas/summary/sum5.cfm> > (March 28, 2016)

Forkenbrock D. J. and Weisbrod G.E (2001). *Guidebook for Assessing the Social and Economic Effects of Transportation Projects*, Report: TRB 456, Transportation Research Board (TRB), Washington, DC.

Forkenbrock D. (1999) “External Costs of Intercity Truck Freight Transportation”, *Transportation Research Part A* 33 (1999) pp. 505-526.

Gangavarapu B, Najafi M. and Salem O. (2004). “Quantitative analysis and comparison of traffic disruption using open-cut and trenchless methods of pipe installation”, *Pipeline Engineering and Construction International Conference*, Baltimore, Maryland, July 13-16.

Gwilliam, K., Kojima, M., and Johnson T. (2004). “Reducing Air Pollution from Urban Transport” *The World Bank*, Washington, DC.

Handy S., Kubly S., Larsen D., Sralla J., Vanka S., and Oden M. (2000). *Economic Impacts of Highway Relief Routes on Small and Medium-Size Communities: Case Studies*, Report: FHWA/TX-0-1843-3, Texas Department of Transportation, Austin, TX.

Hawash A. A. and Nelson J. (2014). Massena Bridge Lateral Slide Replacement, ASPIRE, Spring, 33-35.

Hearn, E.J. (1997). *Mechanics of Materials, Volume 2 - An Introduction to the Mechanics of Elastic and Plastic Deformation of Solids and Structural Materials* (3rd Edition), Butterworth-Heinemann, 225 Wyman Street, Waltham, MA 02451, USA.

Hillman R. n.d., Formulas, Test, Technical Data, Marlboro, NJ.

Hilman (2016). <<https://hilmanrollers-mf.com>> (September 15, 2016)

Hwang J.S., Chang K.C., and Lee G.C. (1990). "Quasi-Static and Dynamic Sliding Characteristics of Teflon-Stainless Steel Interfaces." *Journal Of Structural Engineering*, 2747-2762.

Islam A., Allouche E. N., and Matthews J. C. (2014). *Assessment of social cost savings in trenchless projects*, North American Society for Trenchless Technology (NASST), Orlando, FL.

Innovative Bridge Designs for Rapid Renewal: ABC Toolkit, SHRP 2, Report No. S2-R04-RR-2. <http://onlinepubs.trb.org/onlinepubs/shrp2/SHRP2_S2-R04-RR-1.pdf> (July 20, 2016).

Johnson M. M. (2012). “Move That Bridge.” *Modern Steel Construction Magazine*, <http://msc.aisc.org/globalassets/modern-steel/archives/2012/02/2012v02_move.pdf> (July 20, 2016).

Kelley, K., Clark, B., Brown, V., and Sitzia J., (2003). “Good Practice in the Conduct and Reporting of Survey Research”, *International Journal for Quality in Health Care*, Vol 15, pp 261-266.

Kockelman K. M., Srinivasan S., and Handy S. L. (2000). *Economic Impacts of Highway Relief Routes on Small and Medium-Size Communities: An Econometric Analysis*, Report: FHWA/TX-01/1843-2, Texas Department of Transportation, Austin, TX.

Konduri K., Lownes N., and Angueira J. (2013). *Analyzing the Economic Impacts of Transportation Projects*, Report: CT-2279-F-13-13, Connecticut Department of Transportation, Newington, CT.

Kostyniuk, L., Molnar, L., St. Louis, R., Zanier, N., and Eby, D. (2011). *Societal Costs of Traffic Crashes and Crime in Michigan: 2011 Update*, The University of Michigan Transportation Research Institute, Ann Arbor, MI.

Lesch, T. (2015). Overview of Lateral Slide in Minnesota, Doing ABC with Design Build.

Litman T. (2013). “Transportation Cost and benefit Analysis-Travel Time Costs” *Victoria Transport Policy Institute (VTPI)*, <<http://www.vtpi.org/tca/tca0502.pdf>> (January 5, 2016)

Maibach, M., Schreyer C., Sutter D., Van Essen H., Boon B., Smokers R., Schrotten, A., Doll C., Pawlowska, B., and Bak M. (2008). *Handbook on Estimation of External Costs in the Transportation Sector*, Publication: 07.4288.52, Internalization Measures and Policies for All External Cost of Transport (IMPACT), Delft, Netherlands.

Matthews J. C., Allouche E. N., and Sterling R. L. (2014). “Social Cost Impact Assessment of Pipeline Infrastructure Projects”, *Environmental Impact Assessment Review*, Vol 50, pp 196-202.

McCubbin, D. and Delucci, M. (1999). “The Health Costs of Motor-Vehicle-Related Air Pollution”, *Journal of Transport Economics and Policy*, Vol 33, pp 253-286.

MDOT (2016a). “CO³ Analysis”, *Michigan Department of Transportation (MDOT)*, <http://www.michigan.gov/mdot/0,4616,7-151-9625_54944-227053--,00.html> (June 09, 2016)

MDOT (2016b) “Fast facts 2016”, *Michigan Department of Transportation (MDOT)*, <https://www.michigan.gov/documents/mdot/MDOT_fastfacts02-2011_345554_7.pdf> (April 25, 2016)

MDOT (2013). “Michigan’s Truck-Weight Law and Truck-User Fees”, *Michigan Department of Transportation (MDOT)*, <https://www.michigan.gov/documents/mdot/MDOT_013-4-16TruckWeightsMichigan_418609_7.pdf> (June 10, 2016)

Merth, J. (2008). “Rapid Replacement of Hood Canal Bridge Approach Spans.” *International Bridge Conference*, Pittsburgh, Pa., 139-145.

MOHSP (2014). *Michigan Traffic Crash Facts, Statewide*. Michigan Office of Highway Safety Planning, Lansing MI.

Mills J. B. and Fricker J. D. (2011). *Transportation and Socioeconomic Impacts of Bypasses on Communities: An Integrated Synthesis of Panel Data, Multilevel, and Spatial Econometric Models with Case Studies*, Report: 029PY02, USDOT Region V Regional University Transportation Center (NEXTRANS), Francisco, CA.

Milton Madison Bridge, Lifting of two main spans and lateral sliding of a 740m-long bridge. VSL Heavy Lifting. <http://www.vsl-heavy-lifting.com/references-media/documents/RefPDF_1_111.pdf> (July 20, 2016)

Muller N. and Mendelsohn R., (2007) Measuring the Damages of Air Pollution in the United States, *Journal of Environmental Economics and Management*, Vol 54, pp 1-14.

NHTS (2009). “Online Analysis Tools”, *National Household Travel Survey (NHTS)*, <<http://nhts.ornl.gov/tools.shtml>> (June 22, 2017)

NJDOT (2001). *Road User Cost Manual* New Jersey Department of Transportation (NJDOT), Trenton, NJ.

OQI (2010). “Survey Fundamentals-A Guide to Designing and Implementing Surveys”, *University of Wisconsin-Madison, Office of Quality Improvement (OQI)*, Madison, WI.

Paracha, J. and Mallela, J. (2011). “Road User Cost Analysis for Work Zone Applications”, *Federal Highway Administration (FHWA)* <http://www.ops.fhwa.dot.gov/wz/traffic_analysis/webinar111511jmjp/> (February 12, 2016)

Peters, C. (2016). *How to Design and Analyze a Survey*, <<https://zapier.com/learn/ultimate-guide-to-forms-and-surveys/design-analyze-survey/>> (May 1, 2016)

Ridvanoglu, O. (2016) “Developing Standard Procedures for Structural Aspects of Slide-in Bridges in Accelerated Bridge Construction (ABC),” Master’s Thesis, Western Michigan University at Kalamazoo, MI, in partial fulfillment of the requirements for the degree of Master of Science in Engineering.

Schieck S. and Young R. (2005). *Highway Construction Related Business Impacts: Phase II Report*, Report: FHWA-WY-04/01F, Wyoming Department of Transportation, Laramie, WY.

Searcy, A., Dobry, M., and Kolkman, L. (2012). West Mesquite Interchange at I-15, ASPIRE, Summer, 28-30.

SHRP2 R04 (2015), *ABC Standard Concepts: The Lateral Slide Addendum Report*, Transportation Research Board of the National Academies, Washington, D.C.

Sirikijpanichkul A., Iyengar M., and Ferreira L, (2006). *Valuing Air quality impacts of Transportation: A review of Literature*, School of Urban Development Faculty of Built Environment and Engineering Queensland University of Technology (QUT), Brisbane, Australia.

Slide in Bridge Construction, Case Study. FHWA-HIF-13-057. <<https://www.fhwa.dot.gov/construction/sibc/pubs/hif13057.pdf>> (July 20, 2016).

Stachowiak, G. and Batchelor, A. (2014). *Engineering Tribology*, 4th Edition, Butterworth-Heinemann, 225 Wyman Street, Waltham, MA.

USDOE (2014). “Vehicle Weight Classes & Categories”, *United States Department of Energy (USDOE)* <<http://www.afdc.energy.gov/data/widgets/10380>> (June 10, 2016)

USDOT (2015). “Diesel Powered Passenger Cars and Light Trucks”, *United States Department of Transportation (USDOT)* <http://www.rita.dot.gov/bts/sites/rita.dot.gov/bts/files/publications/bts_fact_sheets/oct_2015/html/entire.html> (June 09, 2016)

USDOT (2014). *Revised Departmental Guidance on Valuation of Travel time in Economic Analysis*, U.S Department of Transportation (USDOT), Washington, DC.

VSL Heavy Lifting® n.d. “Lifting of two main spans and lateral sliding of a 740m-long bridge” <http://www.vsl-heavy-lifting.com/references-media/documents/RefPDF_1_111.pdf> (July 20, 2016)

WisDOT (2014). *Guidance for Conducting an Indirect Effects Analysis*, Wisconsin Department of Transportation WisDOT, Waukesha, WI.

Wolffing C., Liesman J., Young R., and Ksaibati K. (2004). *Highway Construction Related Business Impacts: Phase I Report*, Report: FHWA-WY-04/01F, Wyoming Department of Transportation, Laramie, WY.

Yao, Z., Wei, H., Perugu, H., Liu, H., and Li, Z., (2014). “Sensitivity Analysis of Project Level MOVES Running Emission Rates for Light and Heavy Duty Vehicles”, *Journal of Traffic and Transportation Engineering*, Vol 1, pp 81-96.