

1 DETAIL - STEEL STRAIN POLE

2 DETAIL - COUPLING

A SECTION - ROUND POLE

A' SECTION - 12-SIDED POLYGON (OPTIONAL)

STRAIN POLE REQUIREMENTS

MARK	DESCRIPTION	UNIT	NOT CONNECTED TO TIE-OFF SPANS					CONNECTED TO TIE-OFF SPANS	
			SIZE 1A	SIZE 1B	SIZE 2	SIZE 3	SIZE 4	SIZE 5	
A	POLE LENGTH	FT	30		36	40	36	40	
W	MIN POLE WALL THICKNESS	GR 50 STEEL	IN	5/8		5/8	5/8	5/8	5/8
		GR 65 STEEL	IN	1/2		1/2	1/2	1/2	1/2
B'	POLE DIAMETER - TOP *	IN	12.3 (MIN) ± 1/2		13.96 (MIN) ± 1/2	14.4 (MIN) ± 1/2	14.96 (MIN) ± 1/2	15.4 (MIN) ± 1/2	
B	POLE DIAMETER - BOTTOM *	IN	16.5 ± 1/2		19 ± 1/2	20 ± 1/2	20 ± 1/2	21 ± 1/2	
-	FULL LENGTH TAPER		IN / FT	+0.002	+0.002	+0.002	+0.002	+0.002	+0.002
				-0.000	-0.000	-0.000	-0.000	-0.000	-0.000
E	POLE BASE FILLET WELD	GR 50 STEEL	IN	7/16		7/16	1/2	7/16	1/2
		GR 65 STEEL	IN	7/16		7/16	7/16	7/16	7/16
F	POLE BASE LANDING	IN	5/8		5/8	5/8	5/8	5/8	
-	ANCHOR BOLT DIAMETER	IN	1 3/4	2	2	2	2	2	
-	ANCHOR BOLT HOLE DIAMETER	IN	2 1/16	2 3/16	2 3/16	2 3/16	2 3/16	2 3/16	
-	ANCHOR BOLT CIRCLE DIAMETER	IN	24	27	27	27	29	29	
C	ANCHOR BOLT CHORD	IN	12	13 1/2	13 1/2	13 1/2	14 1/2	14 1/2	
D	BASE PLATE EDGE	IN	15 1/4	17 1/2	17 1/2	17 1/2	20 1/4	20 1/4	
T	BASE PLATE THICKNESS	IN	2 1/4	2 1/4	2 1/4	2 1/4	2 1/4	2 1/4	
P.O.C.H.	12 1/2" POLE BAND CLAMP	FT-IN	21'-6" TO 28'-6"		-	-	-	-	
P.O.C.H.	13 1/2" POLE BAND CLAMP	FT-IN	17'-0" TO 21'-0"	32'-6" TO 34'-6"		-	-	-	
P.O.C.H.	14 1/2" POLE BAND CLAMP	FT-IN	-	25'-6" TO 32'-0"	32'-6" TO 38'-6"	32'-6" TO 34'-6"	-	-	
P.O.C.H.	15 1/2" POLE BAND CLAMP	FT-IN	-	18'-0" TO 25'-0"	25'-6" TO 32'-0"	25'-6" TO 32'-0"	32'-6" TO 38'-6"	-	
P.O.C.H.	16 1/2" POLE BAND CLAMP	FT-IN	-	17'-0" TO 17'-6"	18'-0" TO 25'-0"	18'-0" TO 25'-0"	25'-6" TO 32'-0"	-	
P.O.C.H.	17 1/2" POLE BAND CLAMP	FT-IN	-	-	17'-0" TO 17'-6"	17'-0" TO 17'-6"	18'-0" TO 25'-0"	-	
P.O.C.H.	18 1/2" POLE BAND CLAMP	FT-IN	-	-	-	-	17'-0" TO 17'-6"	-	

- NOTES:
- SEE SIG-020-B FOR LOADING TABLE AND DESIGN CRITERIA.
  - ROUND OR 12-SIDED SECTIONS ARE ALLOWED.
  - MULTI-PLY SECTIONS ARE NOT ALLOWED.
  - STRAIN POLES USED IN APPLICATIONS OTHER THAN TRAFFIC SIGNALS REQUIRE UNIQUE DESIGN CALCULATIONS FOR THE SPECIFIC LOADING CASE.
  - MINIMUM REQUIRED TENSILE STRENGTH (Fu) FOR WELD CONSUMABLES:  
 Fu = 70 KSI FOR GR. 50 POLE  
 Fu = 80 KSI FOR GR. 65 POLE EXCEPT Fu = 70 KSI FOR LONGITUDINAL SEAM WELDS QUALIFIED PER AWS D1.1

- ABBREVIATIONS:
- S.S. = STAINLESS STEEL
  - GA. = GAUGE
  - GR = GRADE
  - O.D. = OUTSIDE DIAMETER
  - I.D. = INSIDE DIAMETER
  - H.S. = HIGH STRENGTH
  - SCH. = SCHEDULE
  - P.O.C.H. = POINT OF CONTACT HEIGHT OF THE POLE BAND CLAMP, MEASURED FROM THE BOTTOM OF THE STRAIN POLE

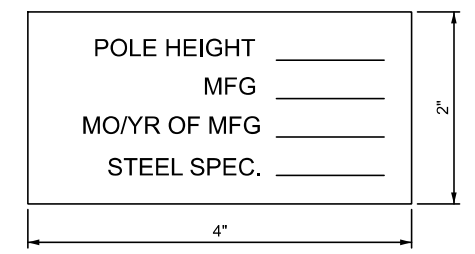

- NOTES:
- ATTACH ID TAG TO STRAIN POLE AT LOCATIONS SHOWN 4" ABOVE BASE OF TUBE, BELOW HANDHOLE, WITH (4) #8 x 3/8" S.S. TYPE U DRIVE SCREWS.
  - STAMP IN LETTERS WITH 3/8" CHARACTERS.
  - STEEL SPEC. REFERS TO THE ASTM SPECIFICATION AND GRADE: "AXXX GR YY"

3 DETAIL - STRAIN POLE S.S. ID TAG

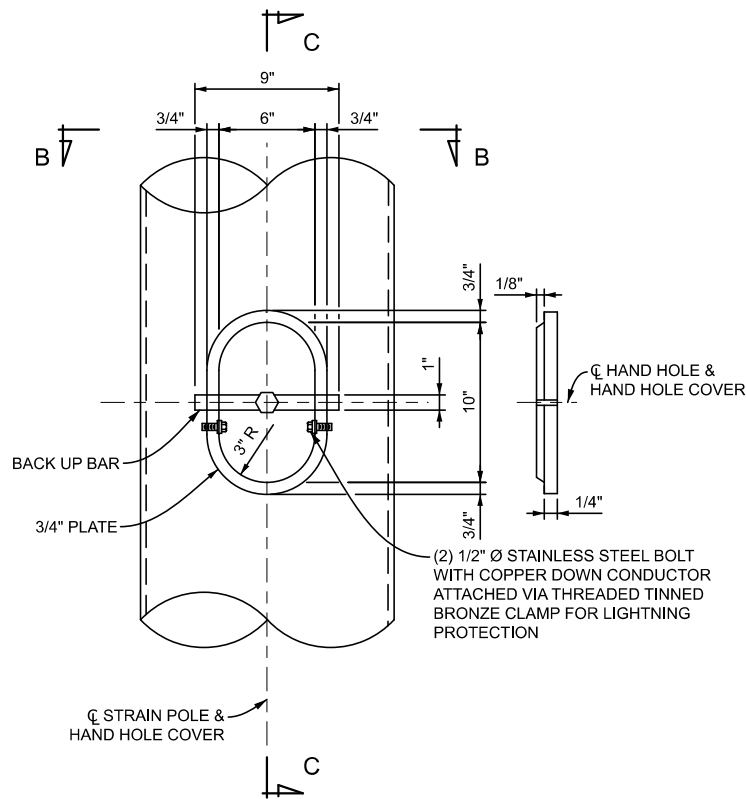

4 DETAIL - HAND HOLE

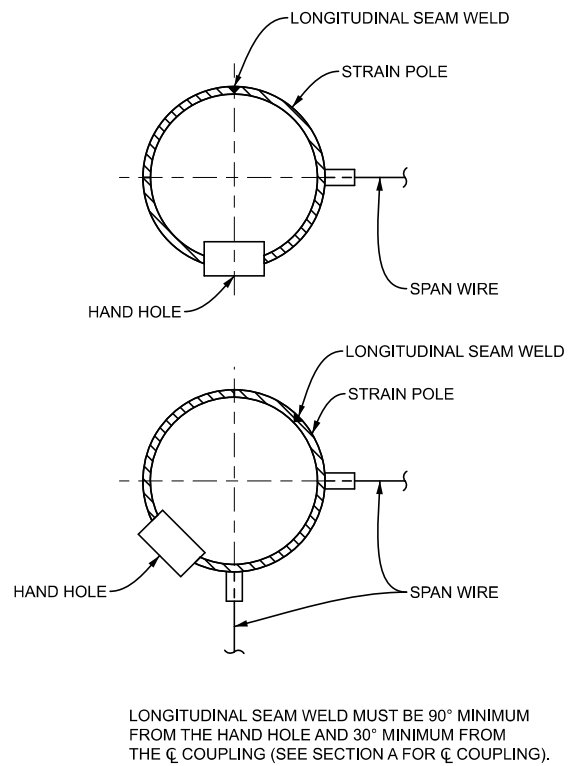

5 DETAIL - STRAIN POLE ORIENTATION

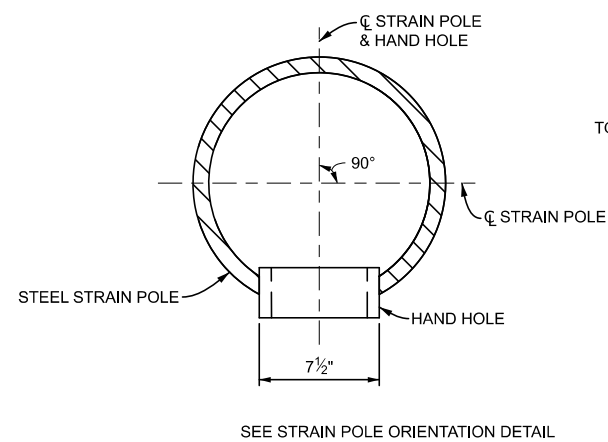

B SECTION - HAND HOLE

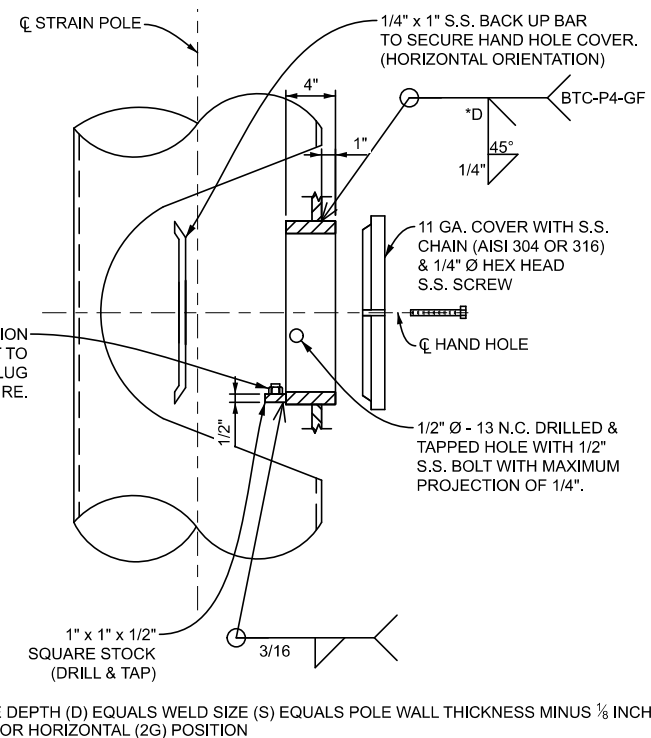

C SECTION - HAND HOLE

\* GROOVE DEPTH (D) EQUALS WELD SIZE (S) EQUALS POLE WALL THICKNESS MINUS 1/8 INCH FLAT (1G) OR HORIZONTAL (2G) POSITION

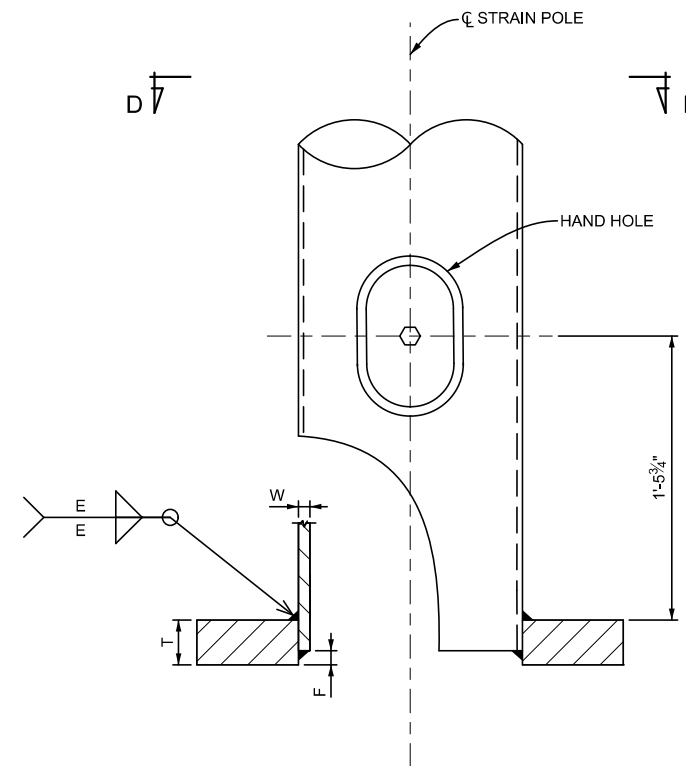

6 DETAIL - BASE PLATE

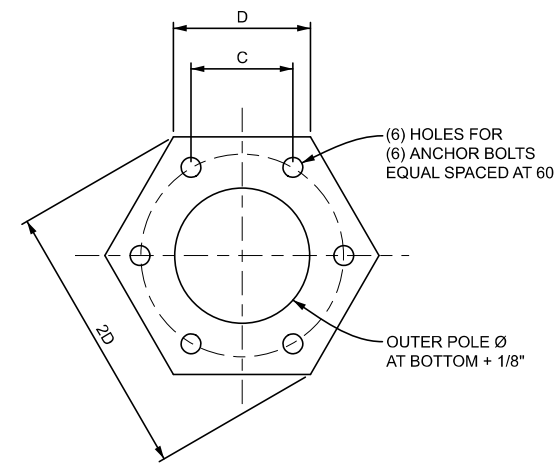

NOTES:  
 1. STRAIN POLE NOT SHOWN FOR CLARITY.  
 2. SEE STRAIN POLE REQUIREMENTS TABLE ON SHEET 2 FOR:  
 ANCHOR BOLT CIRCLE Ø  
 ANCHOR BOLT HOLE Ø  
 ANCHOR BOLT Ø

D SECTION - BASE PLATE

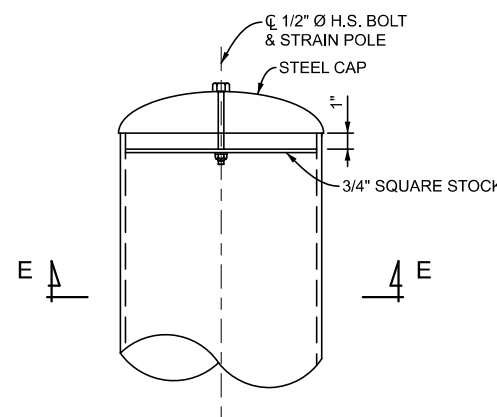

7 DETAIL - STRAIN POLE CAP

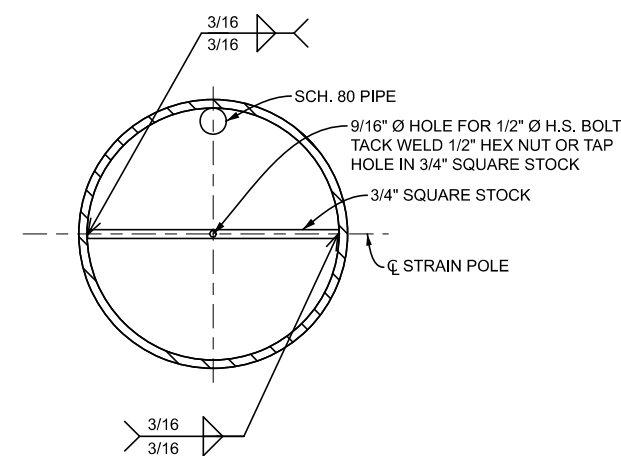

E SECTION - STRAIN POLE CAP

	STANDARD PLAN FOR HAND HOLE & STRAIN POLE ORIENTATION DETAILS			
	(SPECIAL DETAIL) FHWA APPROVAL	08/28/24 PLAN DATE	SIG-021-B	SHEET 3 OF 7

	STANDARD PLAN FOR BASE PLATE AND STRAIN POLE CAP DETAILS			
	(SPECIAL DETAIL) FHWA APPROVAL	08/28/24 PLAN DATE	SIG-021-B	SHEET 4 OF 7 SECT

STRAIN POLE FOUNDATION REQUIREMENTS								
MARK	DESCRIPTION	UNIT	NOT CONNECTED TO TIE-OFF SPANS				CONNECTED TO TIE-OFF SPANS	
			SIZE 1A	SIZE 1B	SIZE 2	SIZE 3	SIZE 4	SIZE 5
A	POLE LENGTH	FT	30		36	40	36	40
	ANCHOR BOLT DIAMETER	IN	1 3/4	2	2	2	2	2
	ANCHOR BOLT CIRCLE DIAMETER	IN	24	27	27	27	29	29
	ANCHOR BOLT LENGTH	IN	72		72	72	72	72
	FOUNDATION DIAMETER	IN	42	48	48	48	48	48

**NOTES:**

- ALL WORK AND MATERIALS MUST BE IN ACCORDANCE WITH THE MDOT STANDARD SPECIFICATIONS FOR CONSTRUCTION. CONSTRUCT STRAIN POLE FOUNDATIONS ACCORDING TO SECTION 718.03 OF THE MDOT STANDARD SPECIFICATIONS FOR CONSTRUCTION.
- IF SOIL CONDITIONS INDICATE THERE IS NO NEED FOR A CASING PAY ITEM AS SHOWN ON THE PLAN, THE CONTRACTOR SHALL REQUEST PERMISSION OF THE ENGINEER TO INSTALL THE FOUNDATION WITHOUT CASING.
- WHEN THE CASING PAY ITEM IS INCLUDED ON THE PLANS FOR A FOUNDATION (DUE TO GRANULAR SOILS, A WET HOLE OR OTHER UNSTABLE CONDITIONS), STEEL CASING (SMOOTH WALLED) IS TO BE INSTALLED TO ENABLE THE FOUNDATION TO BE POURED. THE THICKNESS OF THE STEEL CASING IS TO BE DETERMINED BY THE CONTRACTOR. THE STEEL MUST BE LEFT IN PLACE, SMOOTH WALLED STEEL CASING OUTSIDE DIAMETER TO MEET OR EXCEED FOUNDATION DIAMETER. IF SOIL EXTENDING LATERALLY WITHIN 6 FEET OF THE DRILLED SHAFT FOUNDATION IS LOOSENEED OR OTHERWISE DISTURBED, SCARIFY MATERIAL AT THE BASE OF THE EXCAVATION BELOW THE DEPTH OF DISTURBANCE AND RECOMPACT IN ACCORDANCE WITH 206.03.B OF THE MDOT STANDARD SPECIFICATIONS FOR CONSTRUCTION. COMPACT ALL BACKFILL PLACED ABOVE THE RECOMPACTED BASE OF EXCAVATION IN ACCORDANCE WITH 206.03.B OF THE MDOT STANDARD SPECIFICATIONS FOR CONSTRUCTION.
- WHEN THE CASING PAY ITEM IS CALLED FOR ON THE PLANS, THE STEEL CASING MAY STOP AT THE CONDUIT ENTRANCE TO FOUNDATION. TOP OF FOUNDATION MUST THEN BE FORMED SEPARATELY, EVEN THOUGH THE STEEL CASING STOPS AT THE CONDUIT ENTRANCE. THE CASING PAY ITEM QUANTITY WILL BE PAID FOR BASED ON ACTUAL LINEAR FEET INSTALLED.
- CONSTRUCT STRAIN POLE FOUNDATIONS, CASED OR UNCASED, ACCORDING TO SUBSECTION 820.03.A AND 718 OF THE STANDARD SPECIFICATIONS FOR CONSTRUCTION. ALL WORK AND MATERIALS MUST BE IN ACCORDANCE WITH THE MDOT STANDARD SPECIFICATIONS FOR CONSTRUCTION.
- STEEL REINFORCEMENT MUST CONFORM TO SECTION 905 OF THE MDOT STANDARD SPECIFICATIONS FOR CONSTRUCTION.
- EXPOSED CONCRETE SURFACES MUST BE CAST IN FORMS.
- CONDUITS AND ANCHOR BOLTS MUST BE RIGIDLY INSTALLED BEFORE CONCRETE IS PLACED. ANCHOR BOLTS MUST BE SPACED BY MEANS OF A TEMPLATE. THE CENTER OF THE TEMPLATE MUST COINCIDE WITH THE CENTER OF THE FOUNDATION.
- GROUNDING OF POLE INCLUDES ADDING #4 BARE COPPER GROUND WIRE BONDED BY LISTED MECHANICAL CONNECTION TO FOUNDATION REINFORCING STEEL AND HAVING 24" OF SLACK ABOVE THE TOP OF FOUNDATION.
- INSTALL COPPER CLAD GROUND ROD(S) AS DIRECTED BY ENGINEER AND IN ACCORDANCE WITH CURRENT N.E.C. ALL GROUNDS MUST PROVIDE LESS THAN 10 OHM RESISTANCE TO GROUND.

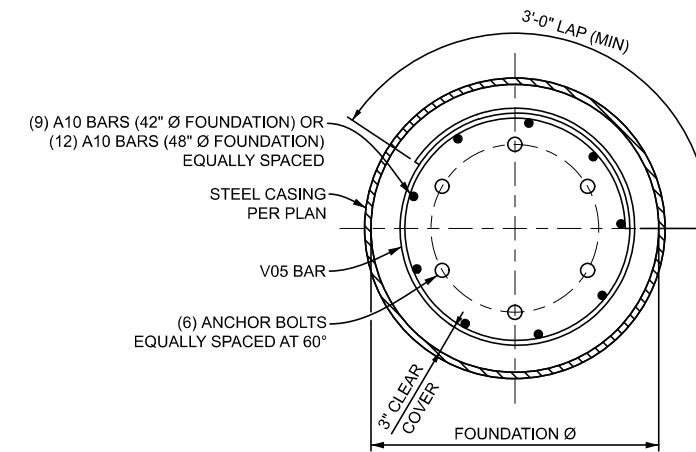

SEE STRAIN POLE FOUNDATION REQUIREMENTS TABLE ON PAGE 5 FOR: ANCHOR BOLT CIRCLE Ø, ANCHOR BOLT Ø, & FOUNDATION Ø

**8** DETAIL - FOUNDATION PLAN

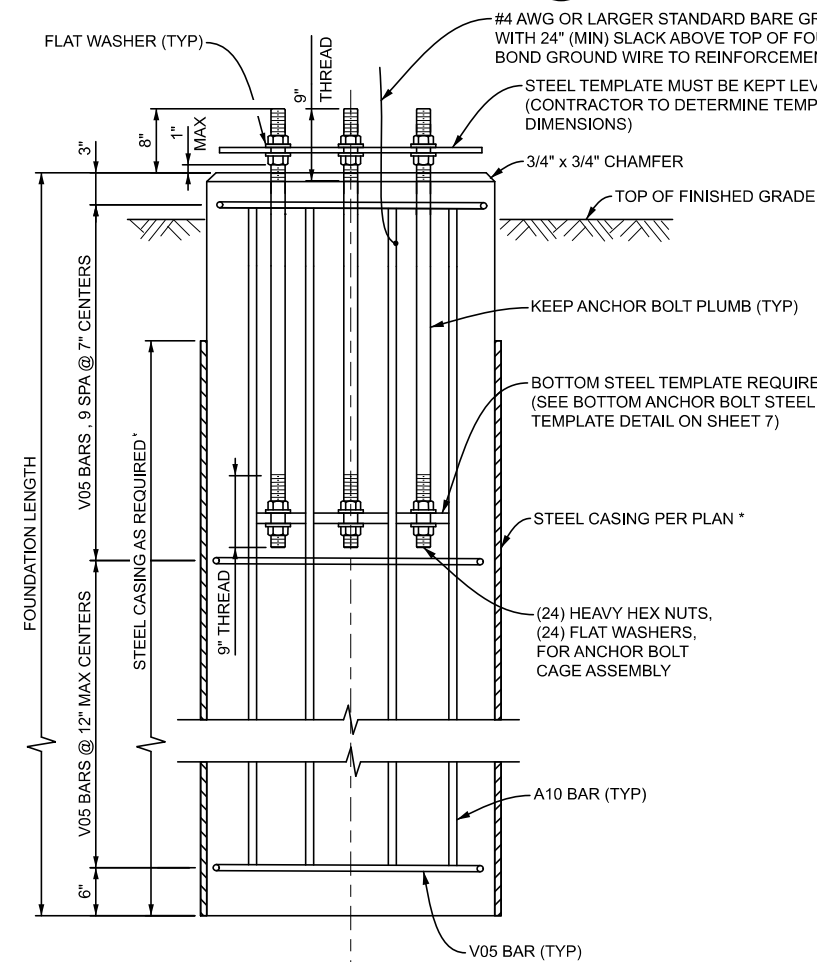

\* SEE FOUNDATION NOTES AND PLANS FOR STEEL CASING PAY ITEM

**9** DETAIL - FOUNDATION ELEVATION

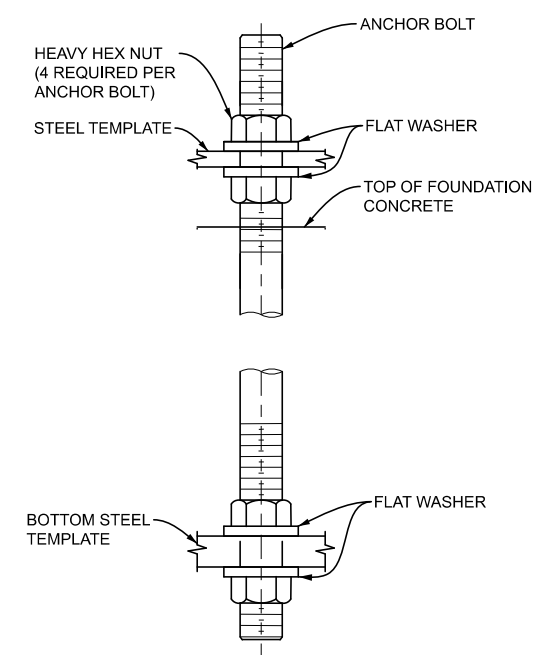

**10** DETAIL - ANCHOR BOLT WASHER PLACEMENT

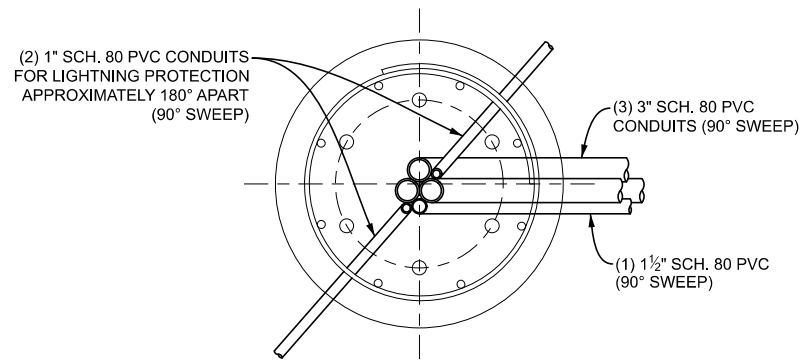

SECURE CONDUITS TOGETHER WITH SUITABLE BANDING TO ENSURE PLACEMENT TOGETHER PRIOR TO CONCRETE POUR.

**F** SECTION-CONDUIT LAYOUT

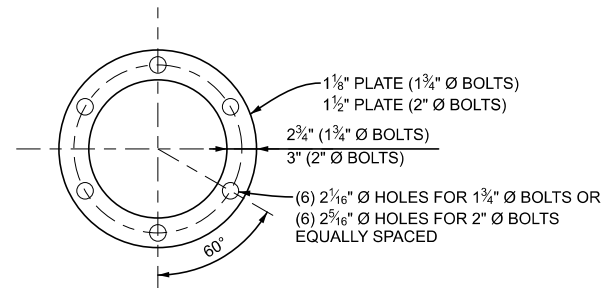

SEE STRAIN POLE FOUNDATION REQUIREMENTS TABLE ON SHEET 5 FOR:  
 ANCHOR BOLT CIRCLE Ø  
 ANCHOR BOLT HOLE Ø  
 FOUNDATION Ø

**12** DETAIL - BOTT. ANCHOR BOLT STEEL TEMPLATE

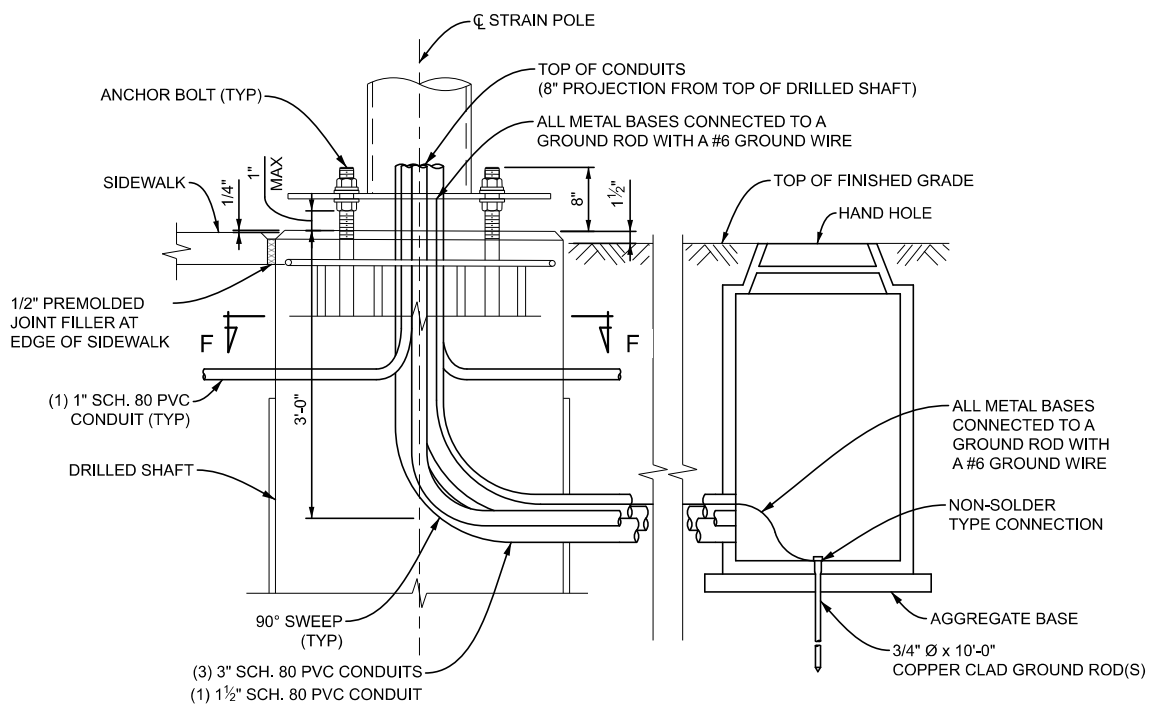

**11** DETAIL - CONDUIT LAYOUT

APPROVED BY: _____ DIRECTOR, BUREAU OF FIELD SERVICES		STANDARD PLAN FOR CONDUIT DETAILS			
APPROVED BY: _____ DIRECTOR, BUREAU OF DEVELOPMENT		(SPECIAL DETAIL) FHWA APPROVAL	08/28/24 PLAN DATE	<b>SIG-021-B</b>	SHEET 7 OF 7

	STANDARD PLAN FOR			
	(SPECIAL DETAIL) FHWA APPROVAL	### PLAN DATE		SHEET OF SECT