

PLAN

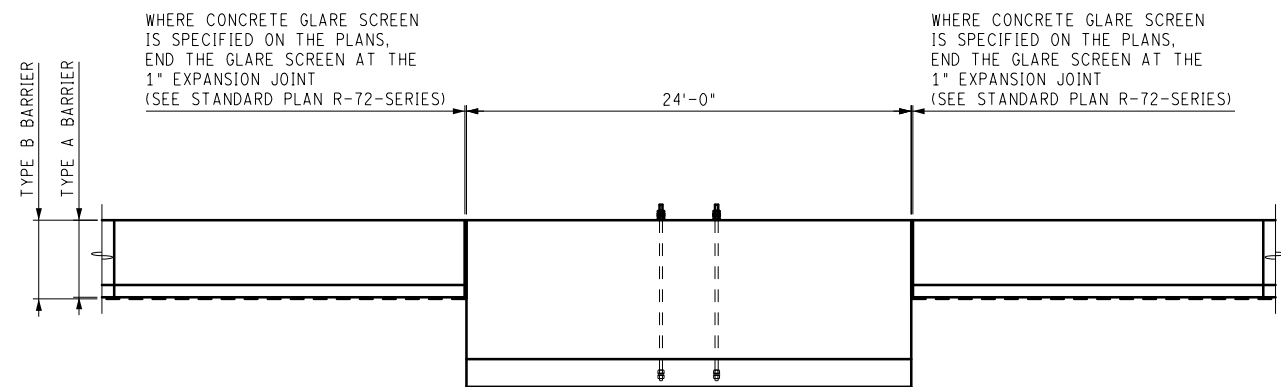

ELEVATION

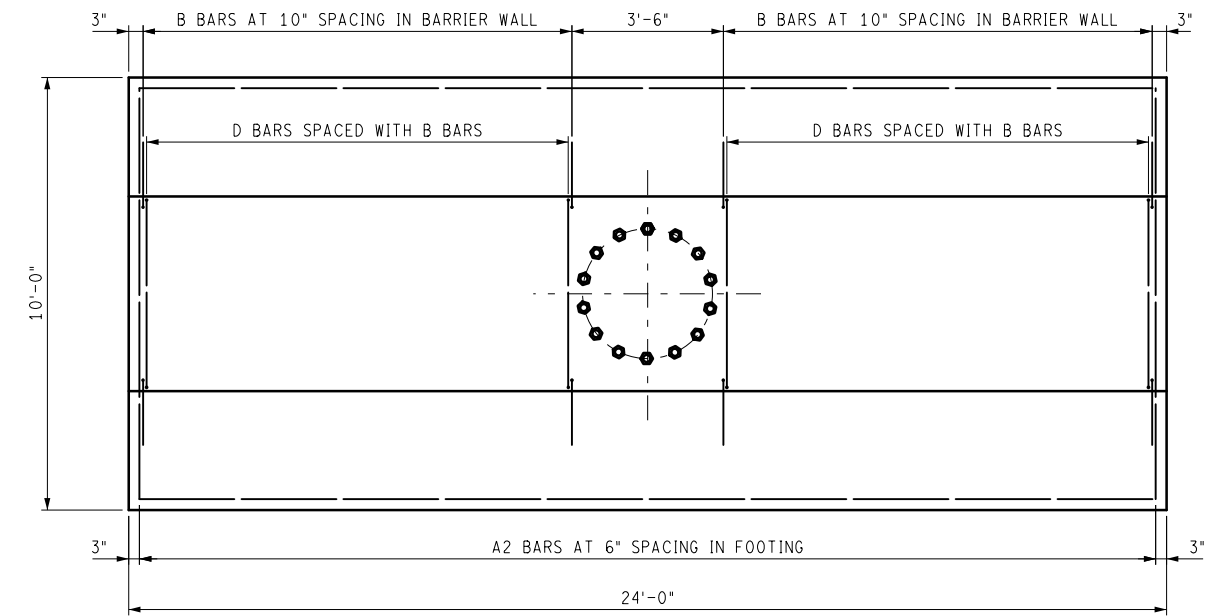

PLAN
SHOWING STEEL REINFORCEMENT

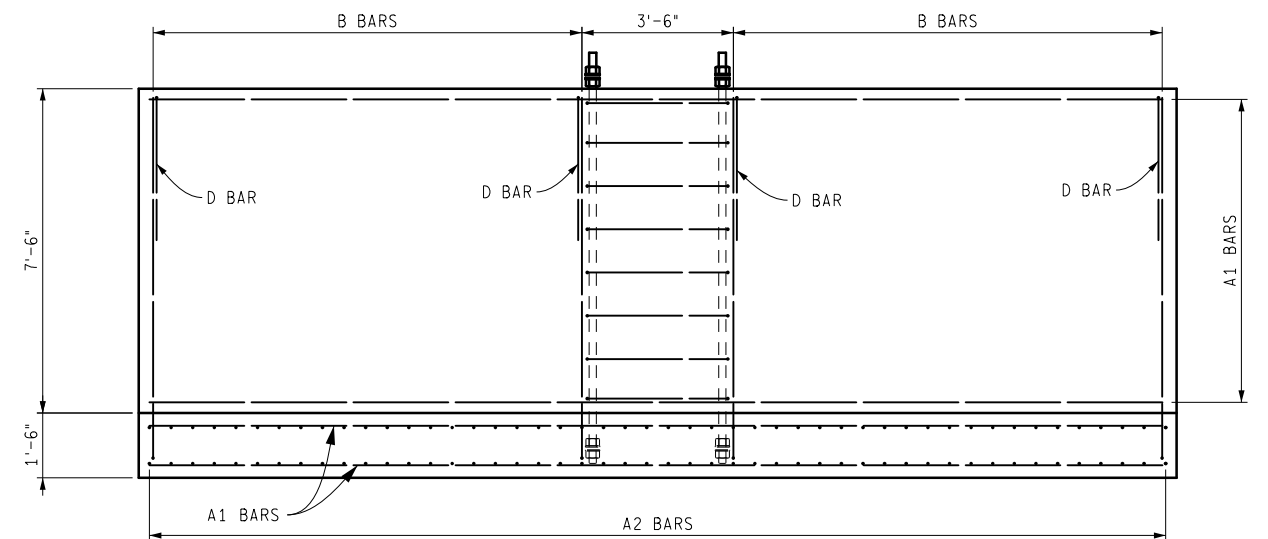

ELEVATION
SHOWING STEEL REINFORCEMENT

NOT TO SCALE

	DEPARTMENT DIRECTOR Bradley C. Wiefelich, P.E.	MICHIGAN DEPARTMENT OF TRANSPORTATION			
	PREPARED BY ANCILLARY STRUCTURES	APPROVED BY: _____ DIRECTOR, BUREAU OF FIELD SERVICES	SPREAD FOOTING FOUNDATION FOR TRUSS TYPE E		
DRAWN BY: HNTB	APPROVED BY: _____ DIRECTOR, BUREAU OF DEVELOPMENT	(SPECIAL DETAIL) F.H.W.A. APPROVAL	08/08/23 PLAN DATE	SIGN-365-B	SHEET 1 OF 8

MICHIGAN DEPARTMENT OF TRANSPORTATION		(SPECIAL DETAIL) F.H.W.A. APPROVAL	08/08/23 PLAN DATE	SIGN-365-B	SHEET 2 OF 8
---------------------------------------	--	---------------------------------------	-----------------------	------------	-----------------

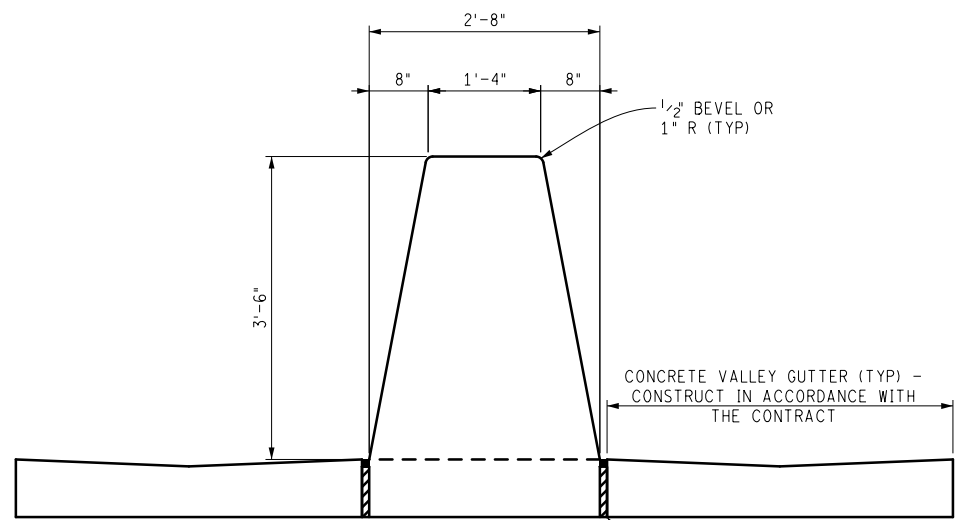

SECTION A-A
(TYPE A BARRIER)

E5 JOINT (TYP)
SEE STANDARD PLAN R-49-SERIES

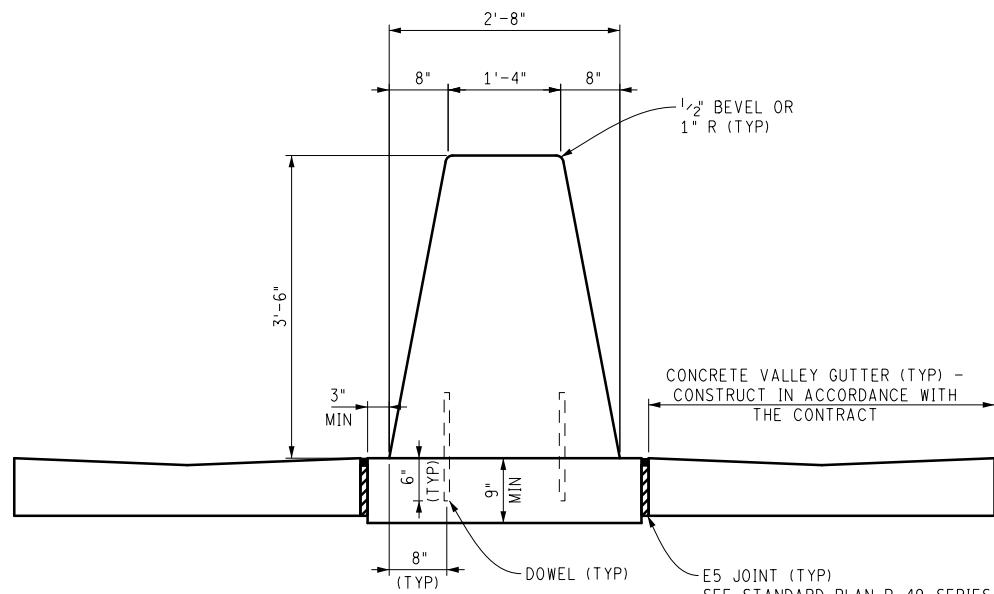

SECTION A-A
(TYPE B BARRIER)

E5 JOINT (TYP)
SEE STANDARD PLAN R-49-SERIES

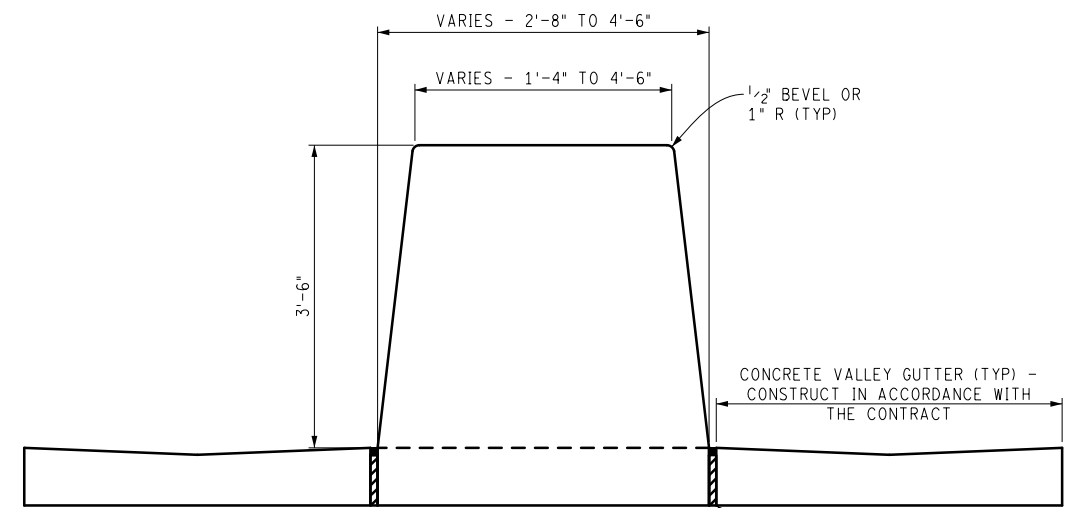

SECTION B-B

(TYPE A BARRIER)
UNIFORMLY TRANSITION THE BARRIER FACES
FROM SINGLE SLOPE SHAPE TO VERTICAL WALL

E5 JOINT (TYP)
SEE STANDARD PLAN R-49-SERIES

* UNIFORMLY TRANSITION E5 JOINT FROM 3" OUTSIDE THE FACE OF THE CONCRETE BARRIER, DOUBLE FACE TO FLUSH WITH THE VERTICAL WALL BARRIER SECTION OVER THE LENGTH OF THE TRANSITION SECTION

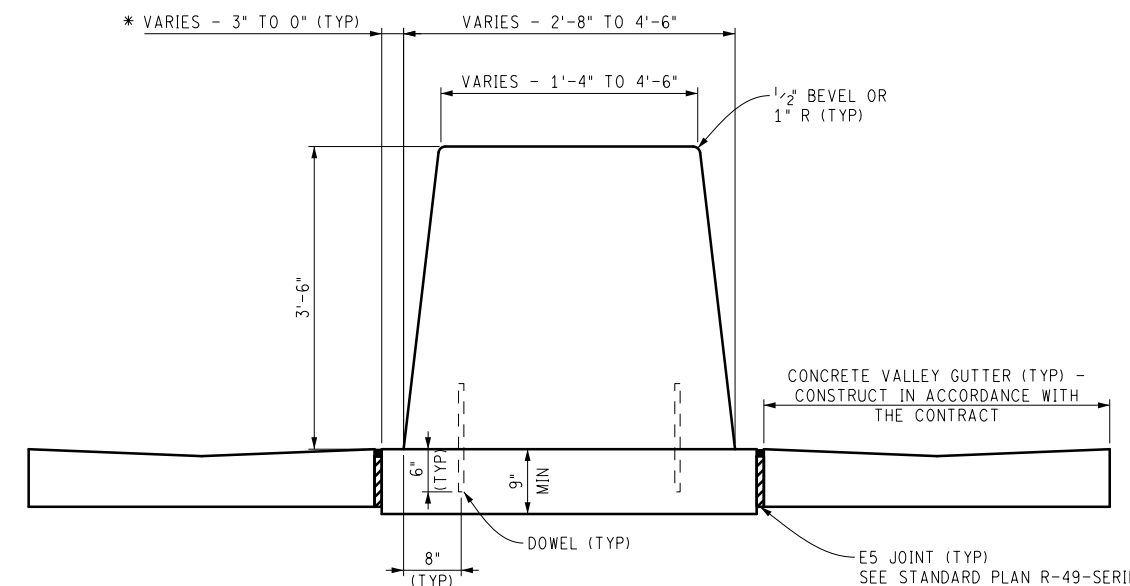

SECTION B-B

(TYPE B BARRIER)
UNIFORMLY TRANSITION THE BARRIER FACES
FROM SINGLE SLOPE SHAPE TO VERTICAL WALL

E5 JOINT (TYP)
SEE STANDARD PLAN R-49-SERIES

NOT TO SCALE

MICHIGAN DEPARTMENT OF TRANSPORTATION

(SPECIAL DETAIL)
F.H.W.A. APPROVAL

08/08/23
PLAN DATE

SIGN-365-B

SHEET
3 OF 8

NOT TO SCALE

MICHIGAN DEPARTMENT OF TRANSPORTATION

(SPECIAL DETAIL)
F.H.W.A. APPROVAL

08/08/23
PLAN DATE

SIGN-365-B

SHEET
4 OF 8

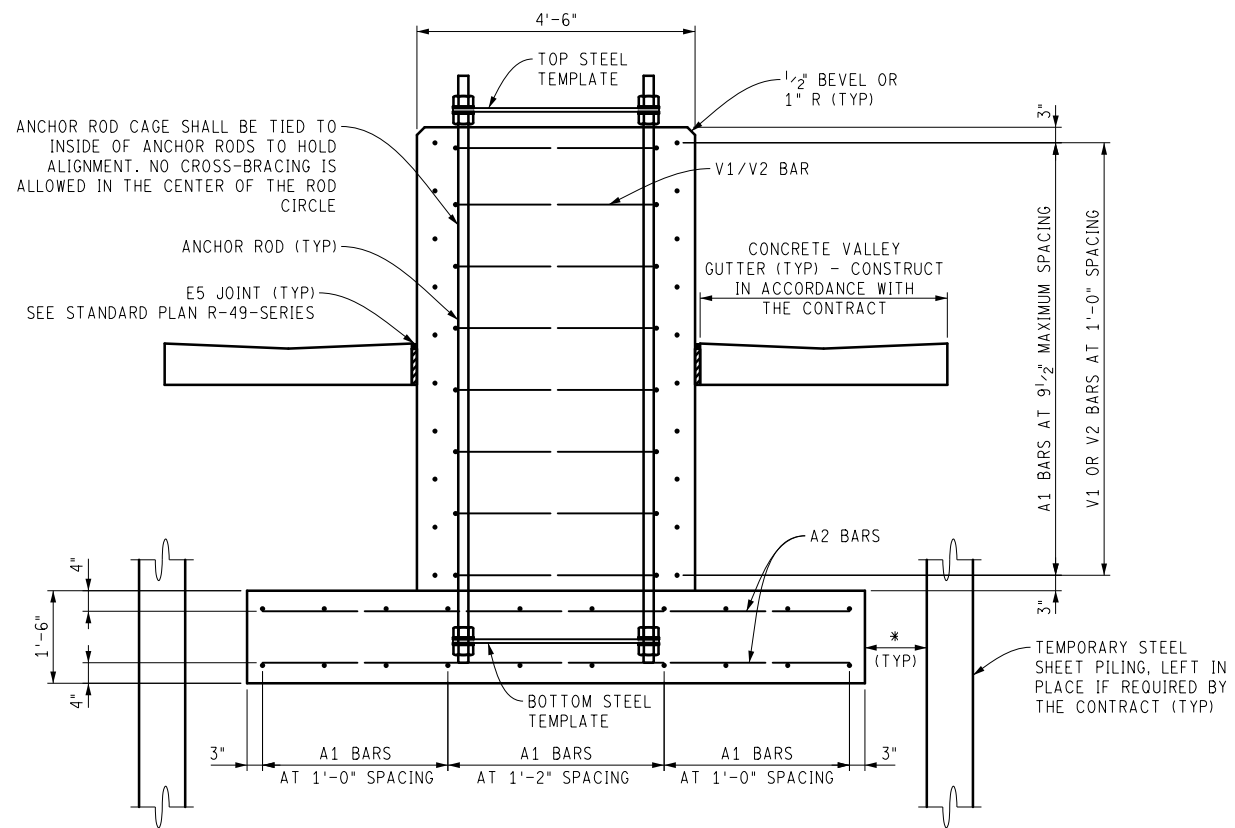

SECTION C-C

* 0" MIN, 18" MAX, OR AS APPROVED BY THE ENGINEER

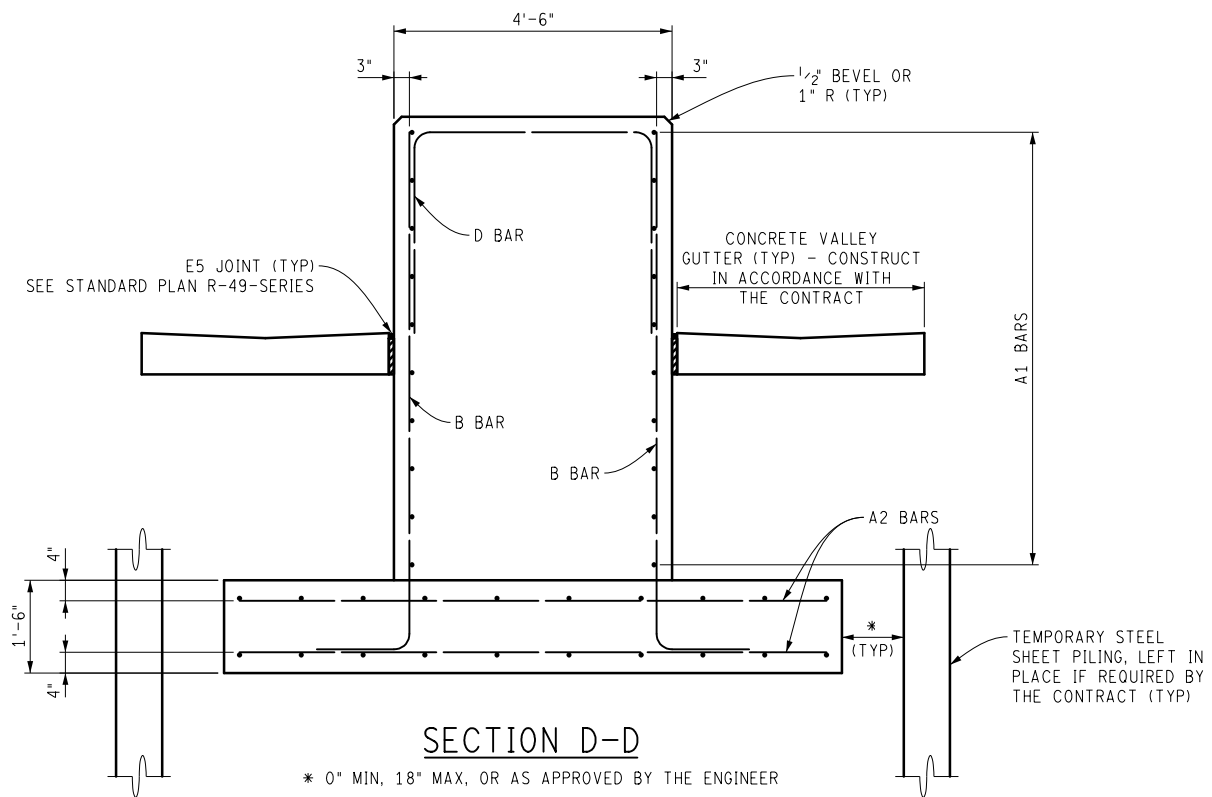

SECTION D-D

* 0" MIN, 18" MAX, OR AS APPROVED BY THE ENGINEER

NOT TO SCALE

MICHIGAN DEPARTMENT OF TRANSPORTATION

(SPECIAL DETAIL)
F.H.W.A. APPROVAL

08/08/23
PLAN DATE

SIGN-365-B

SHEET
5 OF 8

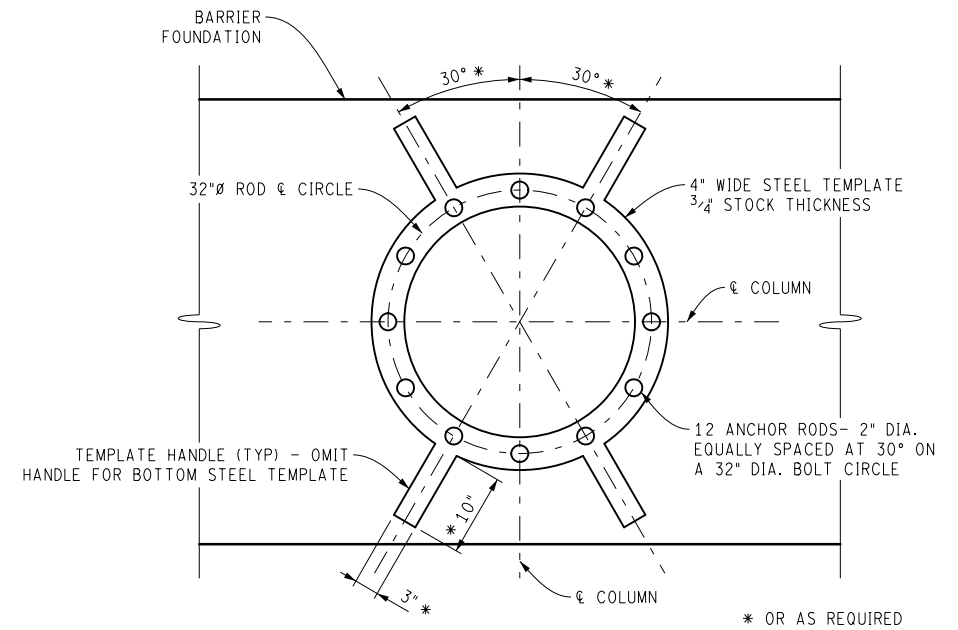

PLAN VIEW TEMPLATE FOR TYPE E TRUSS 50' - 105'

NOTE: OMIT TEMPLATE HANDLES ON BOTTOM STEEL TEMPLATES.

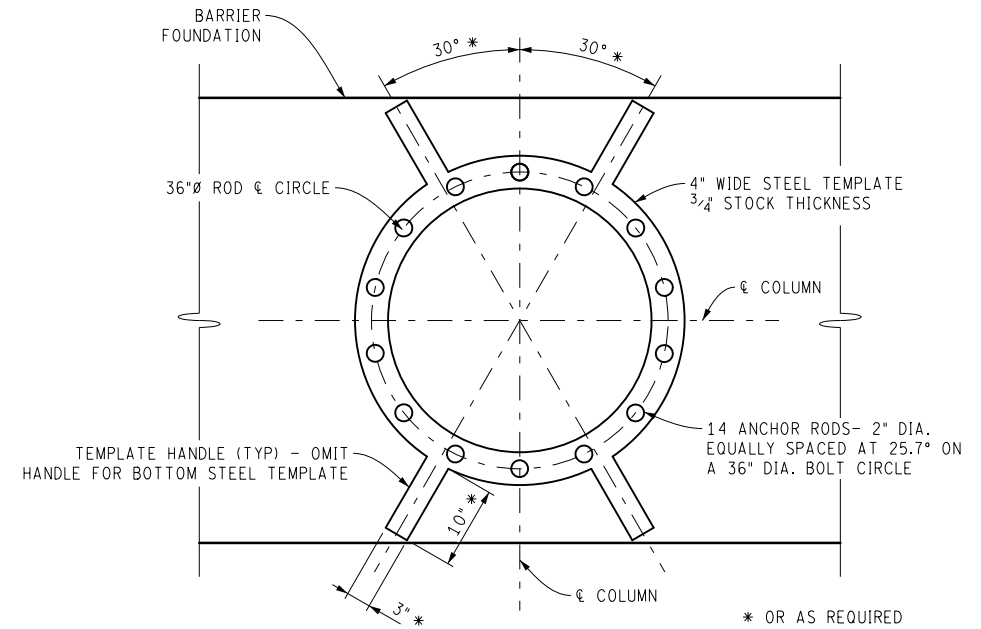

PLAN VIEW TEMPLATE FOR TYPE E TRUSS 110' - 140'

NOTE: OMIT TEMPLATE HANDLES ON BOTTOM STEEL TEMPLATES.

NOT TO SCALE

MICHIGAN DEPARTMENT OF TRANSPORTATION

(SPECIAL DETAIL)
F.H.W.A. APPROVAL

08/08/23
PLAN DATE

SIGN-365-B

SHEET
6 OF 8

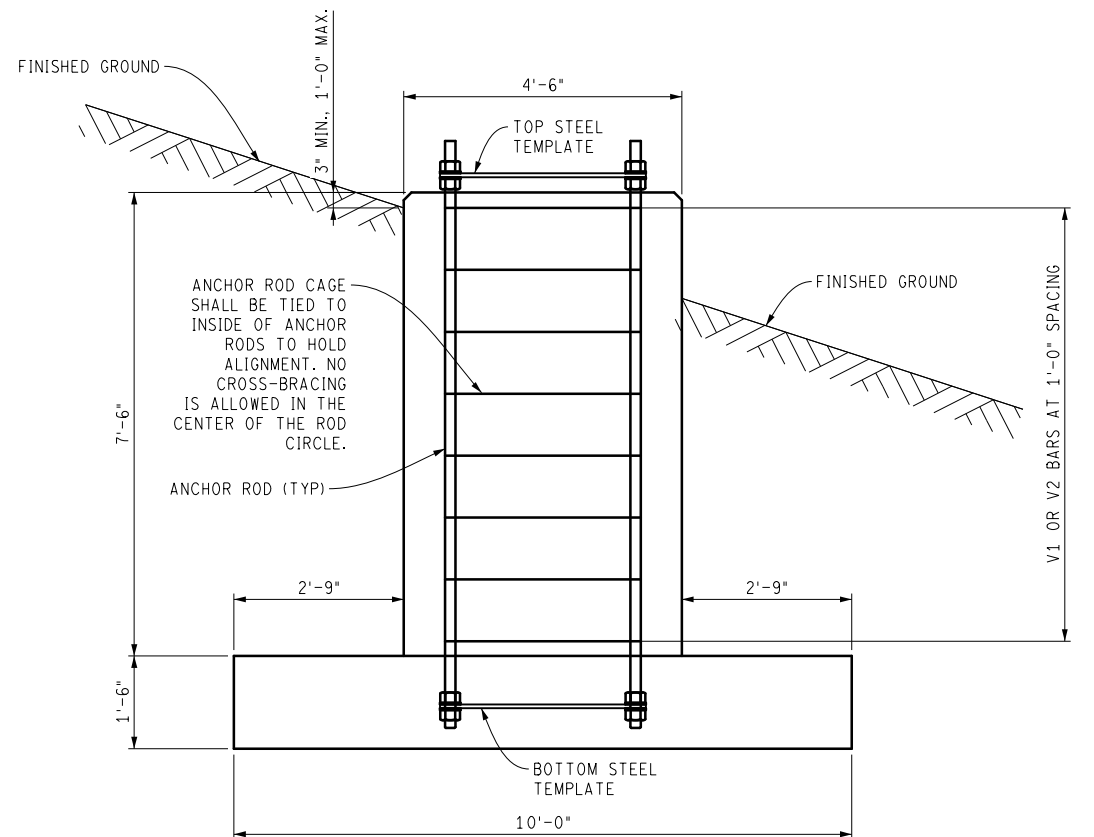

CROSS SECTION AT SHOULDER

NOTE: SEE SECTION C-C AND D-D FOR ADDITIONAL INFORMATION.

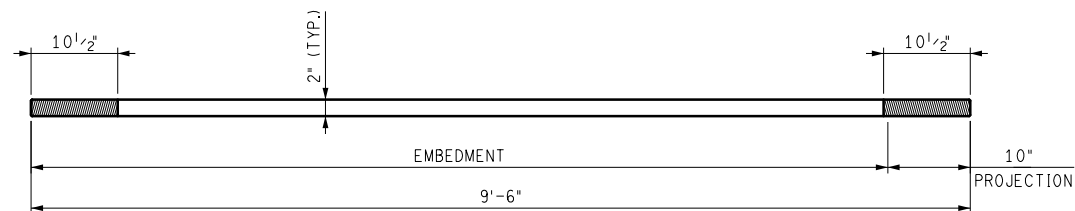

ANCHOR ROD DETAIL

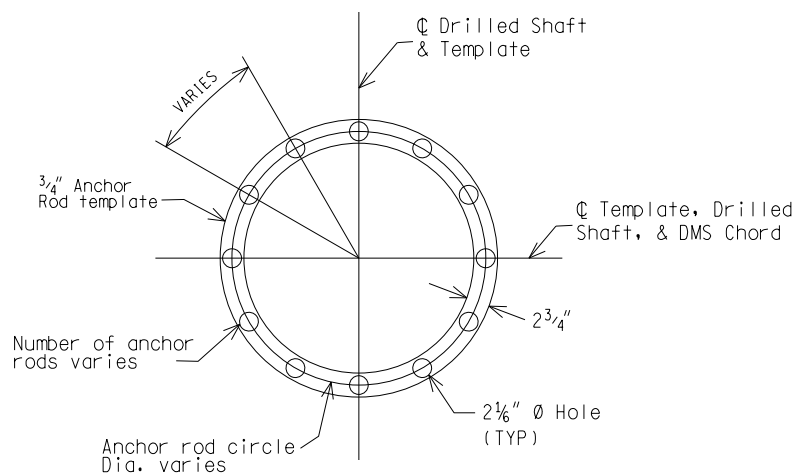

BOTTOM ANCHOR ROD TEMPLATE DETAIL

ANCHOR ROD TABLE		
STRUCTURE TYPE	PROJECTION	NUMBER REQ'D
50' TO 105' TYPE E TRUSS	10"	12
110' TO 140' TYPE E TRUSS	10"	14

NUTS: 4 PER ANCHOR ROD
WASHERS: 4 PER ANCHOR ROD

NOT TO SCALE

MICHIGAN DEPARTMENT OF TRANSPORTATION

(SPECIAL DETAIL)
F.H.W.A. APPROVAL

08/08/23
PLAN DATE

SIGN-365-B

SHEET
7 OF 8

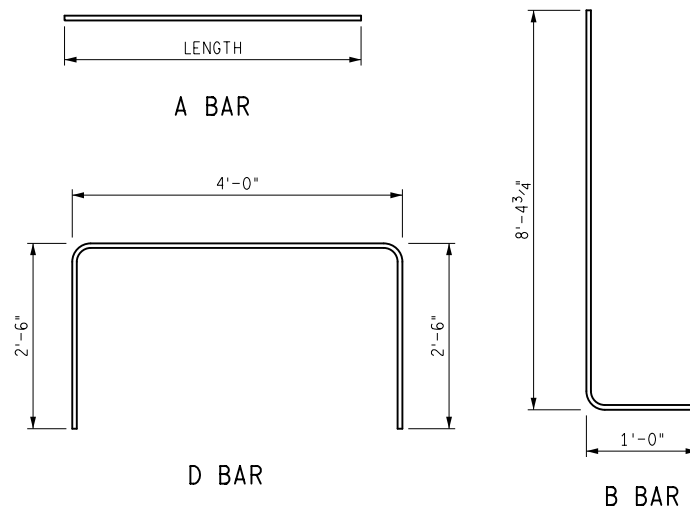

STEEL REINFORCEMENT (EPOXY COATED)				
BAR	BAR SIZE	LENGTH	NUMBER REQUIRED	WEIGHT (LBS)
A1	#5	23'-6"	40	981
A2	#5	9'-6"	96	952
B	#6	9'-4 3/4"	52	734
D	#6	9'-0"	26	352
V1	#4	10'-7 3/8"	8	57
V2	#4	11'-8"	8	63

CONCRETE QUANTITIES

FOOTING	13.4 CYD
VERTICAL WALL SECTION	30.0 CYD
TRANSITION SECTIONS (TYPE A)	19.4 CYD
TRANSITION SECTIONS (TYPE B)	20.1 CYD

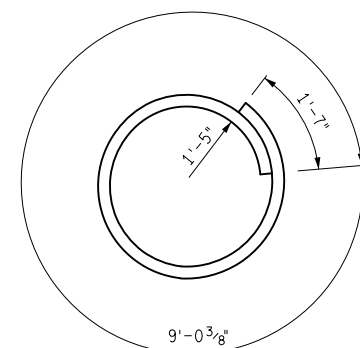

V1 BAR

NOTE: USE WITH 32" DIA. ROD CIRCLE.

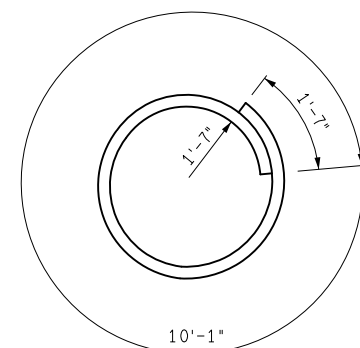

V2 BAR

NOTE: USE WITH 36" DIA. ROD CIRCLE.

NOTES:

TEMPLATES MAY USE MULTIPLE PIECES JOINED BY TWO-SIDED COMPLETE JOINT PENETRATION WELDS, WITH WELDS AT LEAST 2" CLEAR OF ROD HOLES.

THE DESIGN OF THIS FOUNDATION IS BASED ON THE AASHTO LRFD SPECIFICATIONS FOR STRUCTURAL SUPPORTS FOR HIGHWAY SIGNS, LUMINAIRES, AND TRAFFIC SIGNALS, 1ST EDITION, WITH INTERIM REVISIONS THROUGH 2022.

USE OF THESE DETAILS IS ONLY PERMITTED FOR FINISHED GRADES OF 1:3 OR FLATTER.

FOR SLOPES OF 1:6 OR FLATTER, DO NOT USE THIS FOOTING ON COHESIVE SOIL THAT HAS AN UNDRAINED SHEAR STRENGTH (S_u) OF LESS THAN 1250 PSF.

FOR SLOPES BETWEEN 1:3 TO 1:6, DO NOT USE THIS FOOTING ON COHESIVE SOIL THAT HAS AN UNDRAINED SHEAR STRENGTH (S_u) OF LESS THAN 1750 PSF.

DO NOT USE THIS FOOTING ON GRANULAR SOIL WITH STANDARD PENETRATION TEST N60-VALUES LESS THAN 5.

IF STEEL SHEET PILING IS REQUIRED FOR CONSTRUCTION OF THE FOUNDATION, THEN STEEL SHEET PILING, TEMP, LEFT IN PLACE WILL BE PAID FOR SEPARATELY. THE STEEL SHEET PILING MUST BE LEFT IN PLACE AND CUT OFF 1' BELOW FINISHED GROUND.

A 3 1/2' SUBFOOTING MAY BE REQUIRED IF THE WATER TABLE IS HIGH OR WATER SEEPAGE INTO THE FOUNDATION EXCAVATION IS EXPECTED. THE CONCRETE FOR THE SUBFOOTING WILL BE PAID FOR SEPARATELY USING THE APPROPRIATE PAY ITEMS.

DIAMETER OF ROD HOLES IN TEMPLATES SHALL BE 1/16" LARGER THAN ANCHOR ROD DIAMETER.

DO NOT HAMMER ON ANCHOR RODS OR TEMPLATES.

AFTER THE TOP STEEL TEMPLATE IS REMOVED, THREAD NUTS ON TO ROD FLUSH WITH THE ROD END TO PROTECT THREADS UNTIL TRUSS IS ERECTED.

NOT TO SCALE

MICHIGAN DEPARTMENT OF TRANSPORTATION

(SPECIAL DETAIL)
F.H.W.A. APPROVAL

08/08/23
PLAN DATE

SIGN-365-B

SHEET
8 OF 8