

ELEVATION - MAST ARM POLE

TAPERED STEEL MAST ARM POLE		
POLE DIMENSIONS *	LUMINAIRE ARM	MAST ARM LENGTH (FT)
0.4375"-18.00" x 14.78" x 23'-0"	NO	20, 25, 30, 35, 40, 45
0.4375"-18.00" x 13.94" x 29'-0"	YES	
0.5000"-18.00" x 14.78" x 23'-0"	NO	50
0.5000"-18.00" x 13.94" x 29'-0"	YES	

POLE TUBE TAPER IS 0.140 IN/FT  
 \* DIAMETERS ARE GIVEN BY O.D.

TAPERED STEEL MAST ARM			
MAST ARM LENGTH	MAST ARM DIMENSIONS *	MTG HT SINGLE	MTG HT TWIN
20'-0"	0.1793"-16.50" x 13.70" x 20'-0"	19'-0"	18'-6" & 21'-6"
25'-0"	0.1793"-16.50" x 13.00" x 25'-0"		
30'-0"	0.1793"-16.50" x 12.30" x 30'-0"		
35'-0"	0.4290"-16.50" x 13.70" x 20'-0" 0.1793"-14.30" x 12.00" x 16'-9"		
40'-0"	0.4290"-16.50" x 13.70" x 20'-0" 0.1793"-14.30" x 11.30" x 21'-9"		
45'-0"	0.4290"-16.50" x 13.70" x 20'-0" 0.1793"-14.30" x 10.60" x 26'-9"		
50'-0"	0.4290"-17.50" x 14.70" x 20'-0" 0.2391"-15.45" x 11.00" x 31'-11"		

MAST ARM TUBE TAPER IS 0.140 IN/FT  
 \* DIAMETERS ARE GIVEN BY O.D.

NOTES:

- THE DESIGN OF THIS STRUCTURE IS BASED ON CATEGORY I GALLOPING, NATURAL WIND GUSTS, AND TRUCK INDUCED FATIGUE LOADS.
- WELD THE LONGITUDINAL ARM SEAM ON THE INBOARD AND OUTBOARD SECTIONS OF THE TELESCOPIC FIELD SPLICE WITH A COMPLETE JOINT PENETRATION (CJP) WELD WITH A LENGTH EQUAL TO THE TELESCOPIC FIELD SPLICE LENGTH PLUS 6 INCHES. THE LAP OF THE ARM SECTIONS CANNOT EXTEND BEYOND THE LONGITUDINAL ARM SEAM CJP WELD WHEN THE FIELD SPLICE IS ERECTED AND IN ITS FINAL POSITION. IN ADDITION, LONGITUDINAL SEAM WELDS MUST HAVE 60% MINIMUM PENETRATION OR FUSION AND MUST BE CJP FOR A MINIMUM OF 6 INCHES FROM TUBE TO PLATE CJP WELDS.
- SEAM WELDS IN MAST ARM POLE MUST BE 90° ± FROM HAND HOLE AT BASE. SEAM WELDS IN MAST ARM MUST BE LOCATED ON BOTTOM OF MAST ARMS.
- LUMINAIRE ARM IS 11 GAUGE ROUND STEEL WITH 0.140 INCH PER FOOT TAPER.
- BACKING BAR FOR PIPE TO BASE PLATE (□) AND MAST ARM TO MAST ARM PLATE MUST BE MINIMUM 5/16 INCH X 2 INCH PLATE.
- 1/2 INCH DIAMETER (Ø) ROUND STOCK C-HOOK ATTACHED TO ALL POLE SIZES. 1 INCH SCHEDULE (SCH.) 80 PIPE ATTACHED TO ALL POLE SIZES AND INBOARD AND OUTBOARD ARM.
- S.S. DENOTES STAINLESS STEEL. GA. DENOTES GAUGE. O.D. DENOTES OUTSIDE DIAMETER. I.D. DENOTES INSIDE DIAMETER. H.S. DENOTES HIGH STRENGTH.
- ROUND OR 16-SIDED SECTIONS ARE ALLOWED.
- MULTI-PLY SECTIONS ARE NOT ALLOWED.
- A VIBRATION MITIGATION DEVICE IS REQUIRED FOR 50 FOOT ARM AND SHALL BE INSTALLED AS CLOSE AS POSSIBLE TO THE END OF THE ARM.

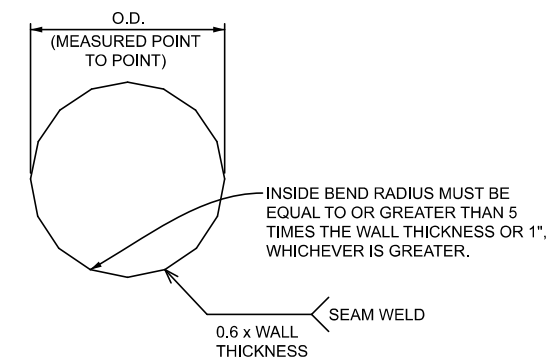

1 DETAIL - 16-SIDED SECTION

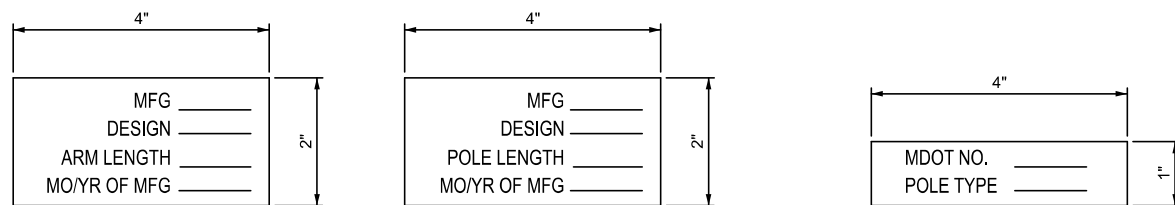

ATTACH TO POLE OR MAST ARM AT LOCATIONS SHOWN 4" FROM BASE OF TUBE BELOW HANDHOLE WITH (4) #8 x 3/8" S.S. TYPE U DRIVE SCREWS. (LETTERS STAMPED IN 3/8" CHARACTERS)

WELD TAG TO EDGE OF BASE PLATE (LETTERS STAMPED IN 3/8" CHARACTERS)

2 DETAIL - ARM/POLE S.S. ID TAG

3 DETAIL - BASE S.S. ID TAG

APPROVED BY: \_\_\_\_\_  
 DIRECTOR, BUREAU OF FIELD SERVICES



STANDARD PLAN FOR  
 TRAFFIC SIGNAL MAST ARM POLE AND  
 MAST ARM DETAILS - CATEGORY I

APPROVED BY: \_\_\_\_\_  
 DIRECTOR, BUREAU OF DEVELOPMENT

DEPARTMENT DIRECTOR  
 BRADLEY C. WIEFERICH, PE

(SPECIAL DETAIL) 07/27/23  
 FHWA APPROVAL PLAN DATE

SIG-031-A

SHEET  
 1 OF 6



STANDARD PLAN FOR  
 MAST ARM POLE AND MAST ARM  
 REQUIREMENTS

DEPARTMENT DIRECTOR  
 BRADLEY C. WIEFERICH, PE

(SPECIAL DETAIL) 07/27/23  
 FHWA APPROVAL PLAN DATE

SIG-031-A

SHEET  
 2 OF 6

SECT

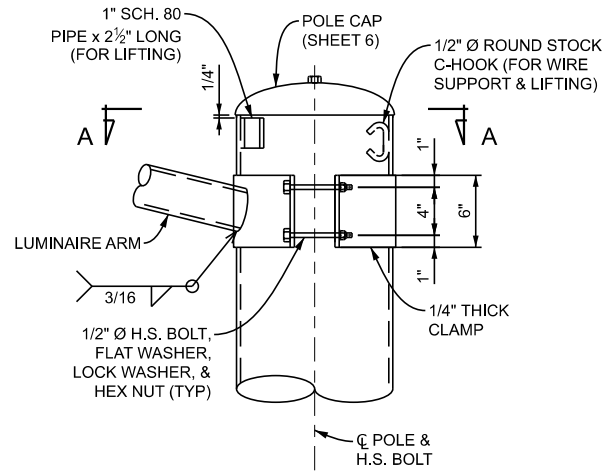

ORIENTATION OF SCH. 80 PIPE 180° FROM HAND HOLE AT BASE & C-HOOK 180° FROM SCH. 80 PIPE

4 DETAIL - LUMINAIRE ARM BRACKET

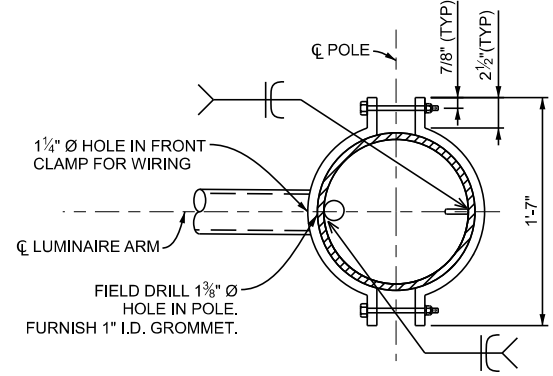

A SECTION - LUMINAIRE ARM BRACKET

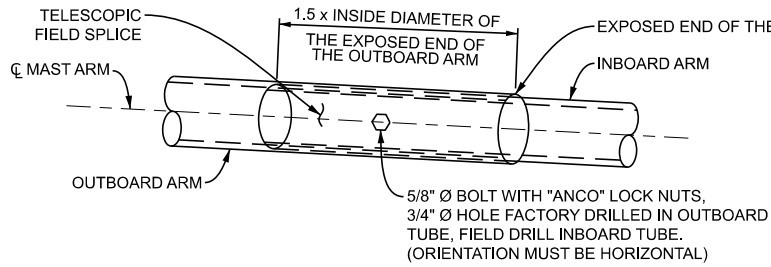

NOTES:  
1. FOR 35'-0" ARMS AND GREATER.  
2. THE INBOARD AND OUTBOARD ARMS MUST FIT TIGHTLY.

5 DETAIL - TELESCOPIC SPLICE

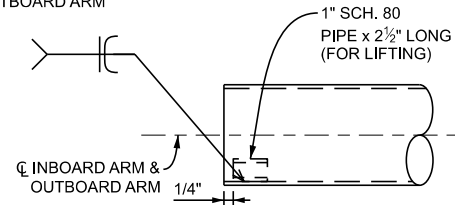

6 INBOARD/OUTBOARD ARM DETAIL - LIFTING DEVICE

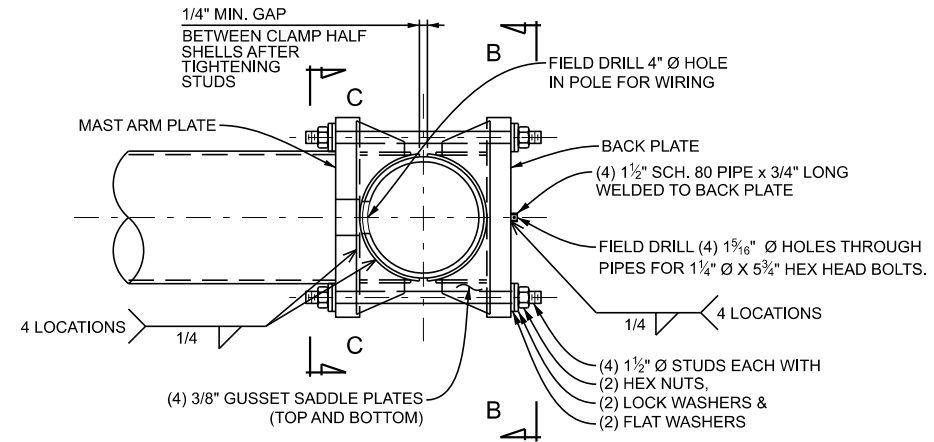

ROUND SECTION SHOWN. SAME CONNECTION DETAILS FOR 16-SIDED SECTION. GUSSET SADDLE PLATES MUST MATCH 16-SIDED POLE SHAPE

7 DETAIL - MAST ARM BRACKET PLAN

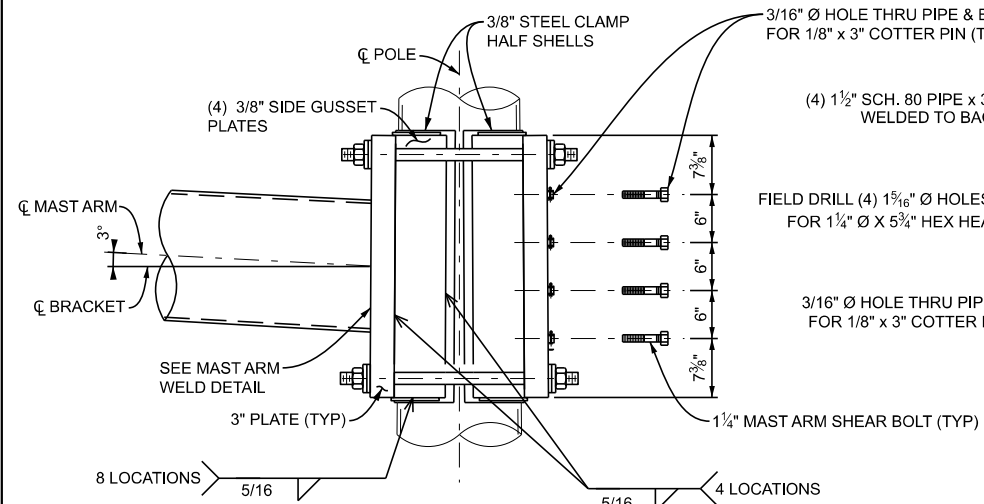

8 DETAIL - MAST ARM BRACKET ELEVATION

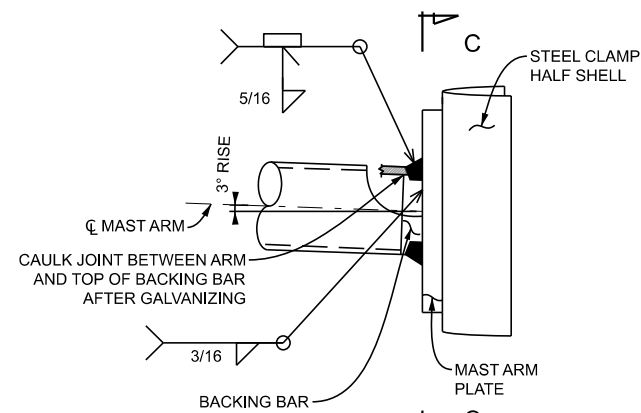

SIDE GUSSET PLATES AND SADDLE PLATES NOT SHOWN FOR CLARITY

9 DETAIL - MAST ARM WELD

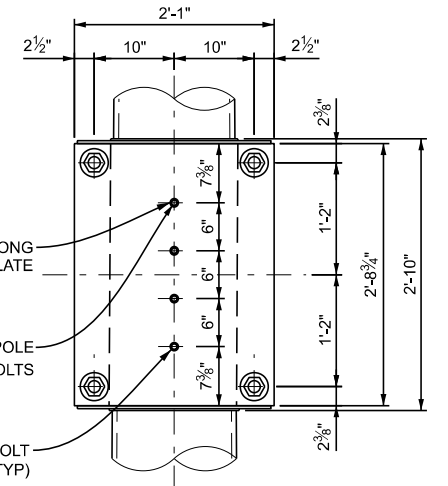

SIDE GUSSET PLATES AND SADDLE PLATES NOT SHOWN FOR CLARITY

B SECTION - BACK PLATE

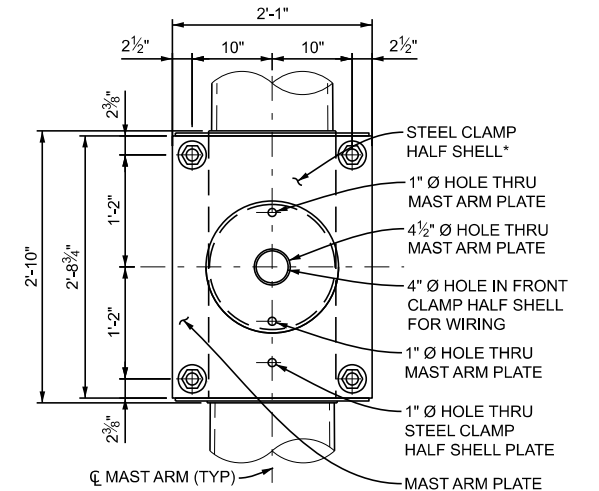

SIDE GUSSET PLATES AND SADDLE PLATES NOT SHOWN FOR CLARITY

\*INSIDE RADIUS OF STEEL CLAMP HALF SHELL SHALL BE WITHIN 1/4" OF THE DESIGNED POLE OUTSIDE RADIUS AT THE INTENDED MOUNTING HEIGHT

C SECTION - MAST ARM PLATE



DEPARTMENT DIRECTOR  
BRADLEY C. WIEFERICH, PE

(SPECIAL DETAIL)  
FHWA APPROVAL

07/27/23  
PLAN DATE

SIG-031-A

SHEET  
3 OF 6

STANDARD PLAN FOR  
LUMINAIRE ARM BRACKET, TELESCOPIC  
SPLICE, AND LIFTING DEVICE DETAILS



DEPARTMENT DIRECTOR  
BRADLEY C. WIEFERICH, PE

(SPECIAL DETAIL)  
FHWA APPROVAL

07/27/23  
PLAN DATE

SIG-031-A

SHEET  
4 OF 6

STANDARD PLAN FOR  
MAST ARM BRACKET DETAILS

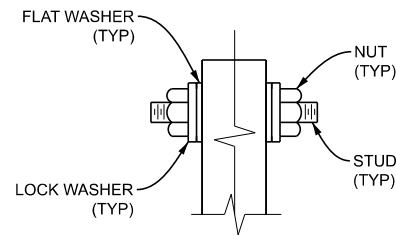

10 DETAIL - MAST ARM BRACKET WASHERS

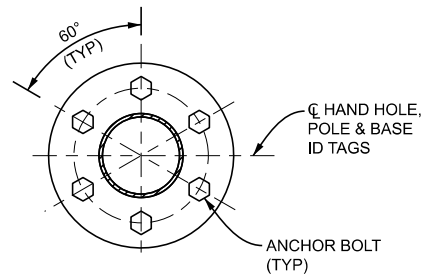

11 DETAIL - ORIENTATION OF HAND HOLE

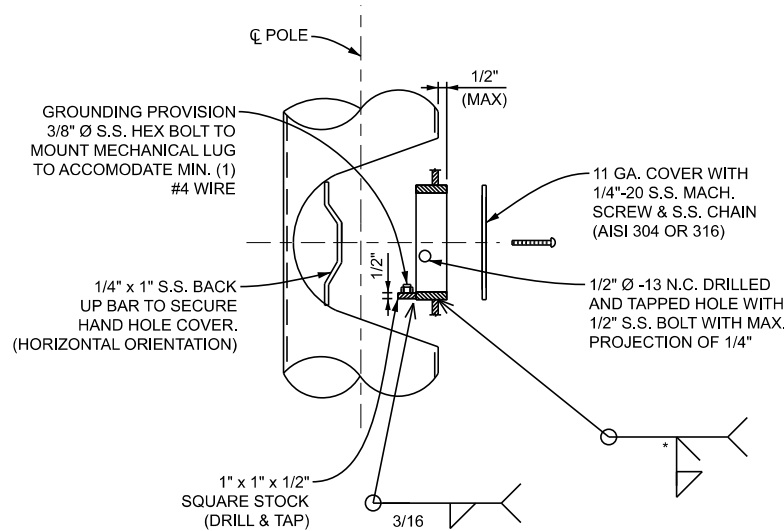

12 DETAIL - 6" X 10" BAR BOTTOM HAND HOLE

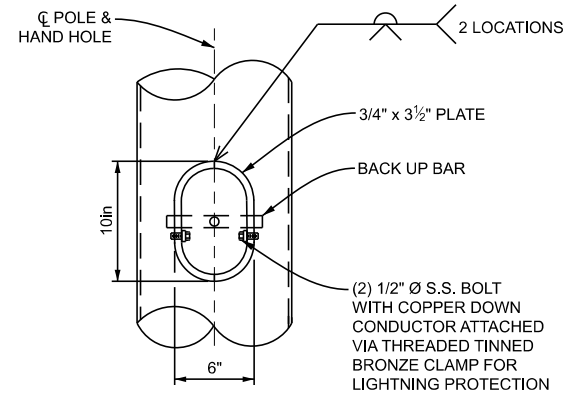

13 DETAIL - 6" X 10" BAR BOTTOM HAND HOLE  
VIEW ROTATED 90 DEGREES

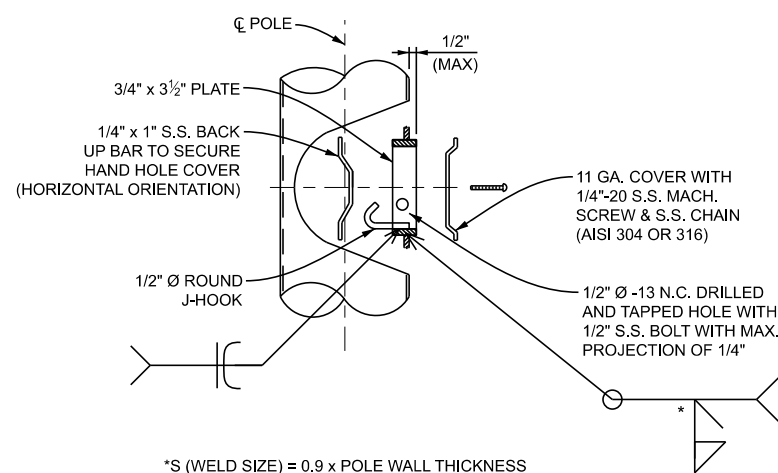

14 DETAIL - 5 1/2" X 8" BAR TOP HAND HOLE

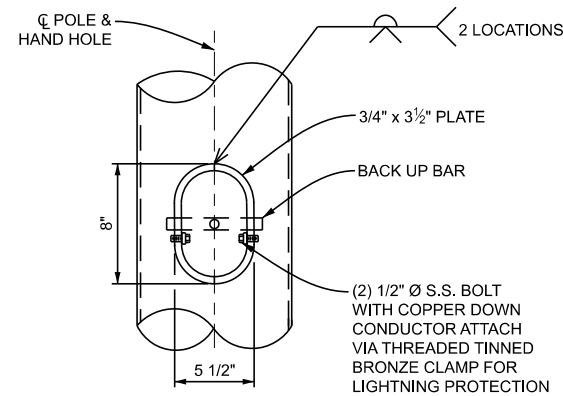

15 DETAIL - 5 1/2" X 8" BAR TOP HAND HOLE  
VIEW ROTATED 90 DEGREES

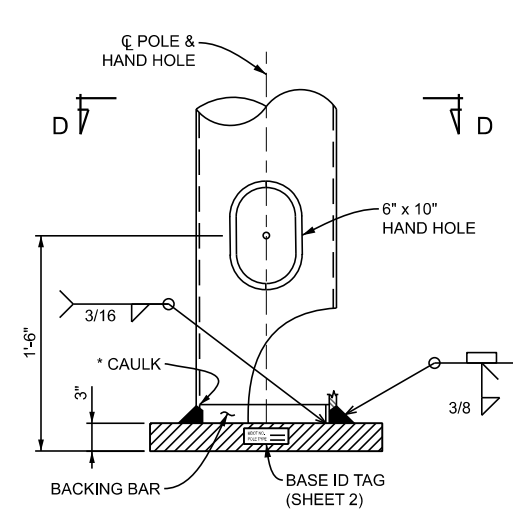

16 DETAIL - BASE PLATE WELD  
VIEW ROTATED 90 DEGREES

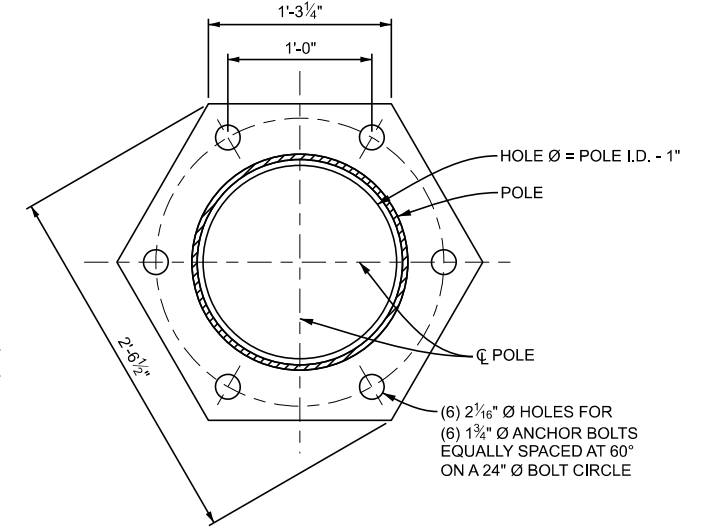

D SECTION - BASE PLATE

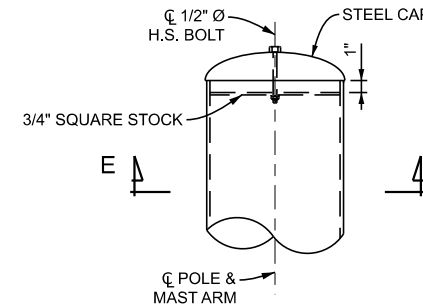

17 DETAIL - POLE AND MAST ARM CAP

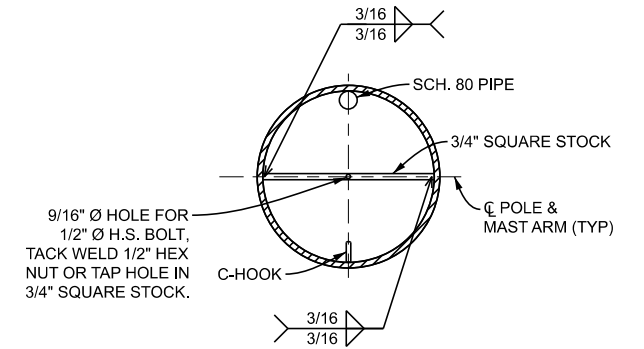

E SECTION - POLE AND MAST ARM CAP

 Michigan Department of Transportation	STANDARD PLAN FOR HAND HOLE DETAILS			SHEET 5 OF 6
	(SPECIAL DETAIL) FHWA APPROVAL	07/27/23 PLAN DATE	SIG-031-A	

 Michigan Department of Transportation	STANDARD PLAN FOR BASE PLATE, MAST ARM POLE CAP, AND MAST ARM CAP DETAILS			SHEET 6 OF 6
	(SPECIAL DETAIL) FHWA APPROVAL	07/27/23 PLAN DATE	SIG-031-A	