

MEDIAN CROSS-OVER

NOTES:

1. FOR "AUTHORIZED VEHICLES ONLY" CROSSOVERS, CONTINUE 6 INCH YELLOW EDGELINE COMPLETELY THROUGH CROSSOVER.

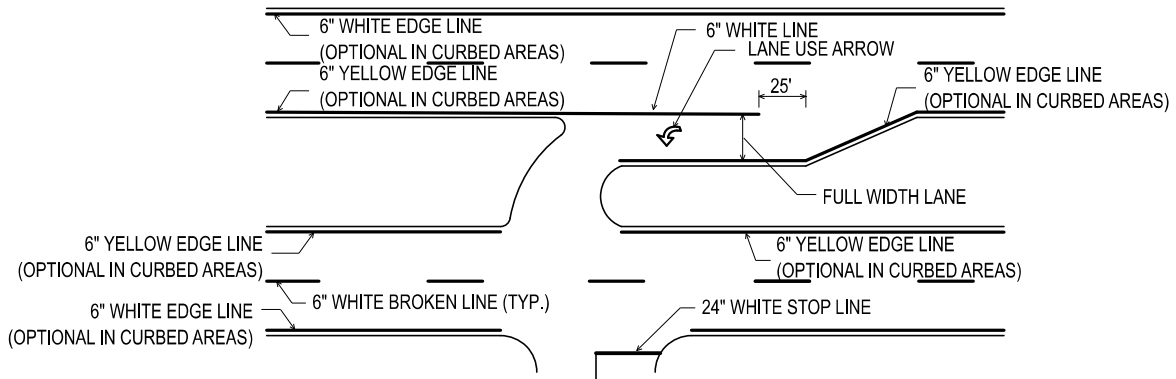

DIRECTIONAL CROSS-OVER

NOTES:

1. INSTALL ARROW(S) AS SHOWN IN PAVE-900 AND PAVE-935. OMIT ARROW(S) IF THE LANE IS NOT FULL WIDTH IN ADVANCE OF THE ISLAND OR THE CHANNELIZING MARKING IS LESS THAN 75 FT IN LENGTH.

NOT TO SCALE

APPROVED BY: _____
DIRECTOR, BUREAU OF FIELD SERVICES

APPROVED BY: _____
DIRECTOR, BUREAU OF DEVELOPMENT



DEPARTMENT DIRECTOR
BRADLEY C. WIEFERICH, PE

STANDARD PLAN FOR
CROSS-OVER
PAVEMENT MARKINGS

11/22/2023
FHWA APPROVAL

09/13/2023
PLAN DATE

PAVE-985-F

SHEET
1 OF 4

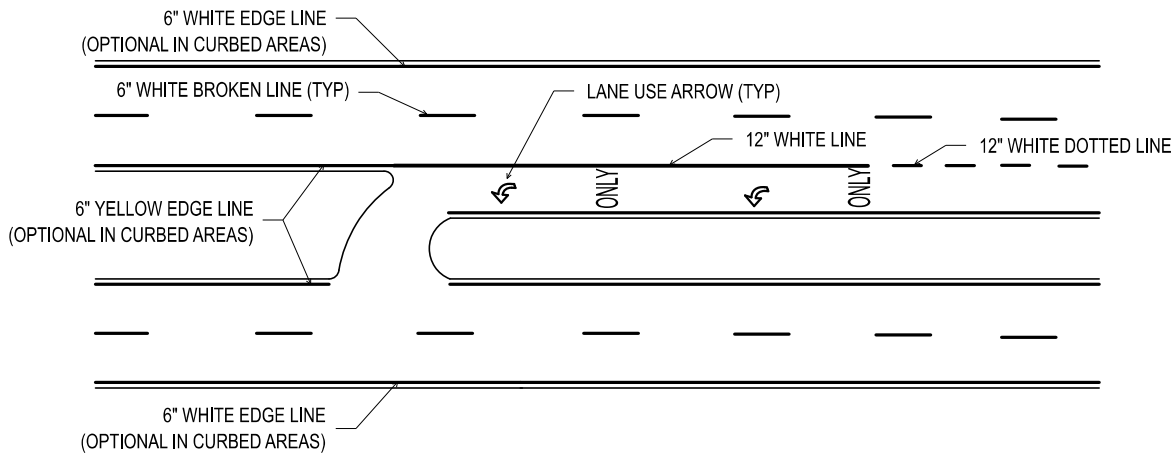

DIRECTIONAL CROSS-OVER WITH LANE DROP

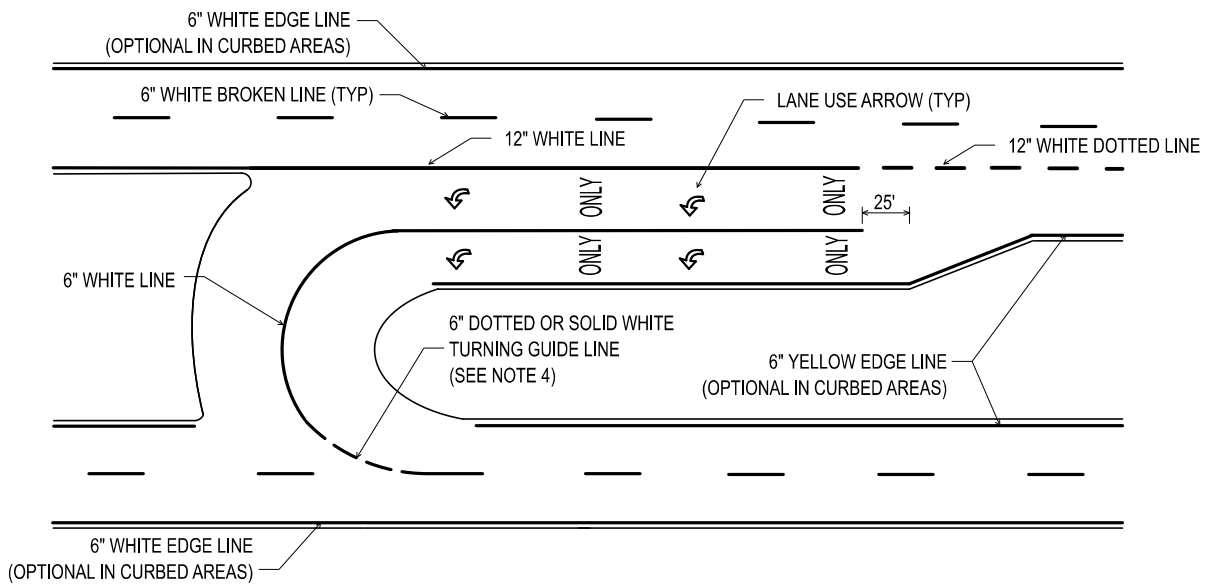

DIRECTIONAL CROSS-OVER WITH DUAL LANES

NOTES:

1. SEE PAVE-900 AND PAVE-935 FOR LOCATION OF SPECIAL MARKINGS.
2. "ONLY" LEGENDS ARE NOT REQUIRED WHEN ALL CROSSOVER LANES ARE DEVELOPED. IF AT LEAST ONE CROSSOVER LANE IS A DROP LANE, THEN "ONLY" LEGENDS ARE REQUIRED IN ADDITION TO THE ARROWS.
3. INCLUDE A DOTTED TURNING GUIDELINE FOR ALL DOUBLE TURN MOVEMENTS.
4. EVALUATE ROAD CONDITIONS WHEN MORE THAN TWO RECEIVING LANES ARE PRESENT TO DETERMINE WHICH LANE THE TURNING GUIDE LINE SHOULD LEAD TO (RADIUS CONSIDERATIONS, LANES DROPPING, ETC.).



DEPARTMENT DIRECTOR
BRADLEY C. WIEFERICH, PE

STANDARD PLAN FOR
CROSS-OVER
PAVEMENT MARKINGS

11/22/2023
FHWA APPROVAL

09/13/2023
PLAN DATE

PAVE-985-F

SHEET
2 OF 4

NOT TO SCALE

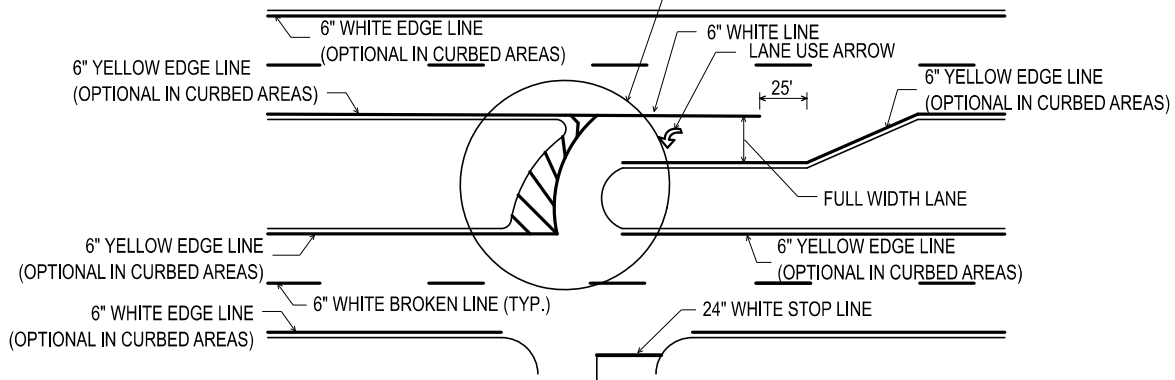
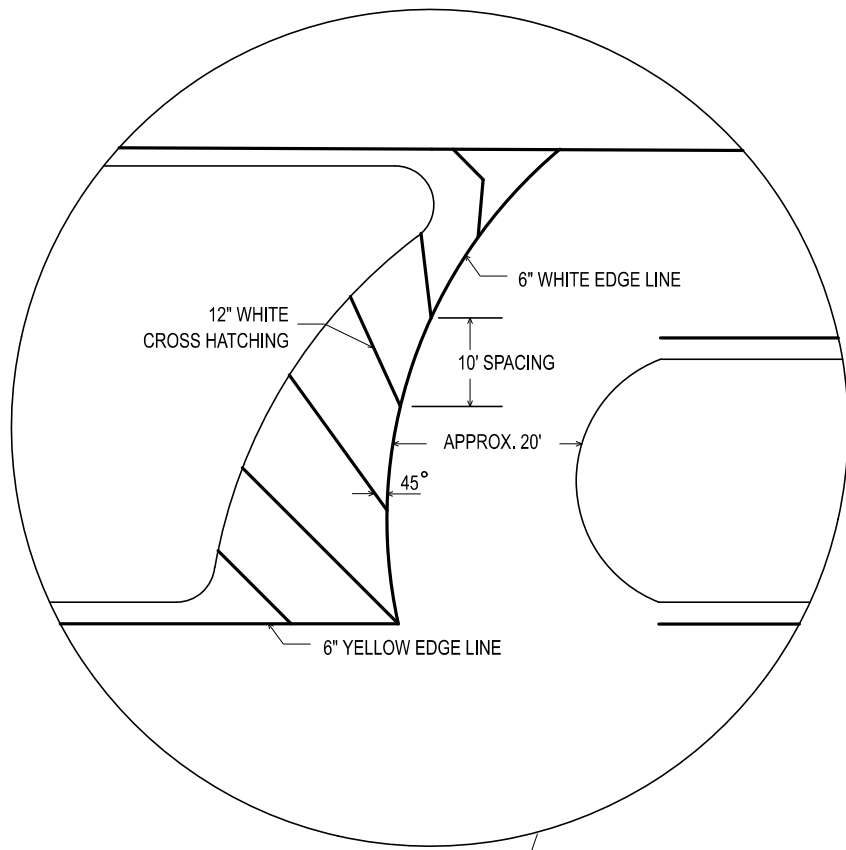

CROSS HATCHING FOR WIDE SINGLE-LANE CROSS-OVERS

NOTES:

1. SEE PAVE-900 AND PAVE-935 FOR LOCATION OF SPECIAL MARKINGS.
2. "ONLY" LEGENDS ARE NOT REQUIRED WHEN ALL CROSSOVER LANES ARE DEVELOPED. IF AT LEAST ONE CROSSOVER LANE IS A DROP LANE, THEN "ONLY" LEGENDS ARE REQUIRED IN ADDITION TO THE ARROWS.
3. CROSS HATCHING IS RADIAL TO ALWAYS POINT UPWARDS IN THE DIRECTION OF TRAFFIC MOVEMENT AND MAINTAIN A 45 DEGREE ANGLE TO THE EDGELINE. 10 FOOT SPACING IS MEASURED ALONG THE WHITE EDGELINE.



DEPARTMENT DIRECTOR
BRADLEY C. WIEFERICH, PE

STANDARD PLAN FOR
CROSS-OVER
PAVEMENT MARKINGS

11/22/2023
FHWA APPROVAL

09/13/2023
PLAN DATE

PAVE-985-F

SHEET
3 OF 4

NOT TO SCALE

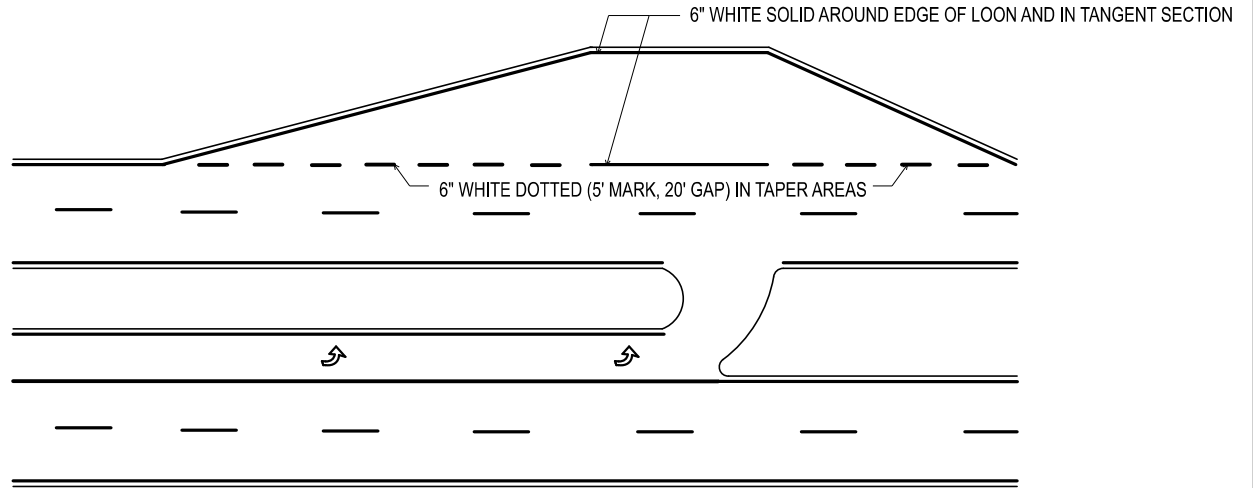

LOON DETAILS

NOTES:

1. SEE PAVE-900 AND PAVE-935 FOR LOCATION OF SPECIAL MARKINGS.
2. "ONLY" LEGENDS ARE NOT REQUIRED WHEN ALL CROSSOVER LANES ARE DEVELOPED. IF AT LEAST ONE CROSSOVER LANE IS A DROP LANE, THEN "ONLY" LEGENDS ARE REQUIRED IN ADDITION TO THE ARROWS.



DEPARTMENT DIRECTOR
BRADLEY C. WIEFERICH, PE

STANDARD PLAN FOR
CROSS-OVER
PAVEMENT MARKINGS

11/22/2023
FHWA APPROVAL

09/13/2023
PLAN DATE

PAVE-985-F

SHEET
4 OF 4