

A HIGH PRESSURE METHOD OF BITUMEN
EXTRACTION FROM ASPHALT PAVEMENT
Final Report

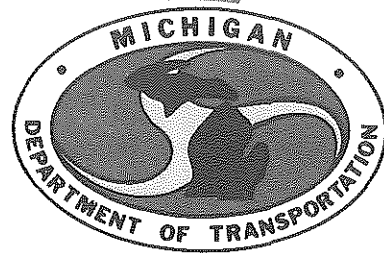

MATERIALS and TECHNOLOGY DIVISION

A HIGH PRESSURE METHOD OF BITUMEN
EXTRACTION FROM ASPHALT PAVEMENT
Final Report

T. J. Houser
Chemistry Department
Western Michigan University
Kalamazoo, Michigan 49008

In Cooperation with the
Michigan Department of Transportation
and the Federal Highway Administration

Michigan Transportation Commission
William C. Marshall, Chairman;
Rodger D. Young, Vice-Chairman;
Hannes Meyers, Jr., Shirley E. Zeller,
Stephen Adamini, Nansi I. Rowe
James P. Pitz, Director
Lansing, June 1990

Disclaimer

The contents of this report reflect the views of the author who is responsible for the facts and the accuracy of the data presented herein. The contents do not necessarily reflect the official views or policies of the Michigan Department of Transportation or the Federal Highway Administration. This report does not constitute a standard, specification, or regulation.

INTRODUCTION

The various departments of transportation in the United States perform numerous asphalt extraction tests yearly for quality control and performance evaluation. The most critical step in the test procedure is the quantitative extraction of bitumen from the asphalt paving mixtures. Other determinations that are useful in evaluating these mixtures are of the particle size distribution of the aggregate after extraction, and of the hardness of the extracted bitumen after solvent removal (penetration test).

The procedure used currently by the Michigan Department of Transportation (MDOT) and others (ASTM Designation D 2172-81) involves soaking the paving mixture in a solvent followed by removal of the solvent by a complex procedure employing a centrifuge and repeated solvent washings. The solvents that have been found to be effective and are extensively used are trichloroethylene (TCE), 1,1,1-trichloroethane, and methylene chloride. Unfortunately, because of their chlorine content, these solvents present a serious problem for hazardous waste disposal and to the health of personnel. In order to minimize this problem MDOT eliminated TCE from use for their field extractions, although it is still being used in the Lansing laboratory. A commercial solvent, Bioact-DG-1 (which is primarily limonene, a terpine hydrocarbon), has been substituted for TCE in field testing because it provides the advantages that it does not pose a hazardous waste disposal problem nor does it appear to present a health hazard to exposed personnel, although some workers have had some irritation due to its odor. In addition, it can be used with essentially the same equipment as used with TCE. However, Bioact does present four disadvantages when compared to the commonly used solvents: a) it is significantly more expensive, b) it extracts the bitumen more slowly, c) its high boiling point does not allow for separation from the extract in order to perform the penetration test, d) phase separations occur when stored outside during the winter in Michigan.

The Vermont Agency of Transportation has used xylene in place of TCE and although it performs satisfactorily as a solvent, it is reported to present a serious health hazard to personnel. In addition, its low volatility prevents separation from the bitumen. They ran preliminary tests to determine the suitability of substituting Bioact for xylene which indicated that Bioact was able to extract the bitumen satisfactorily but took about twice as long and again was significantly more expensive than xylene. The alternate methods for bitumen extraction involving solvent reflux or vacuum filtration also have been developed for use with the chlorinated solvents, which does not circumvent the aforementioned problems caused by these materials.

Thus, the objective of this program was to develop a new method of bitumen extraction that is competitive in both cost and time consumption with those currently in use, that can be performed by non-professional staff, and would not use chlorinated or aromatic solvents.

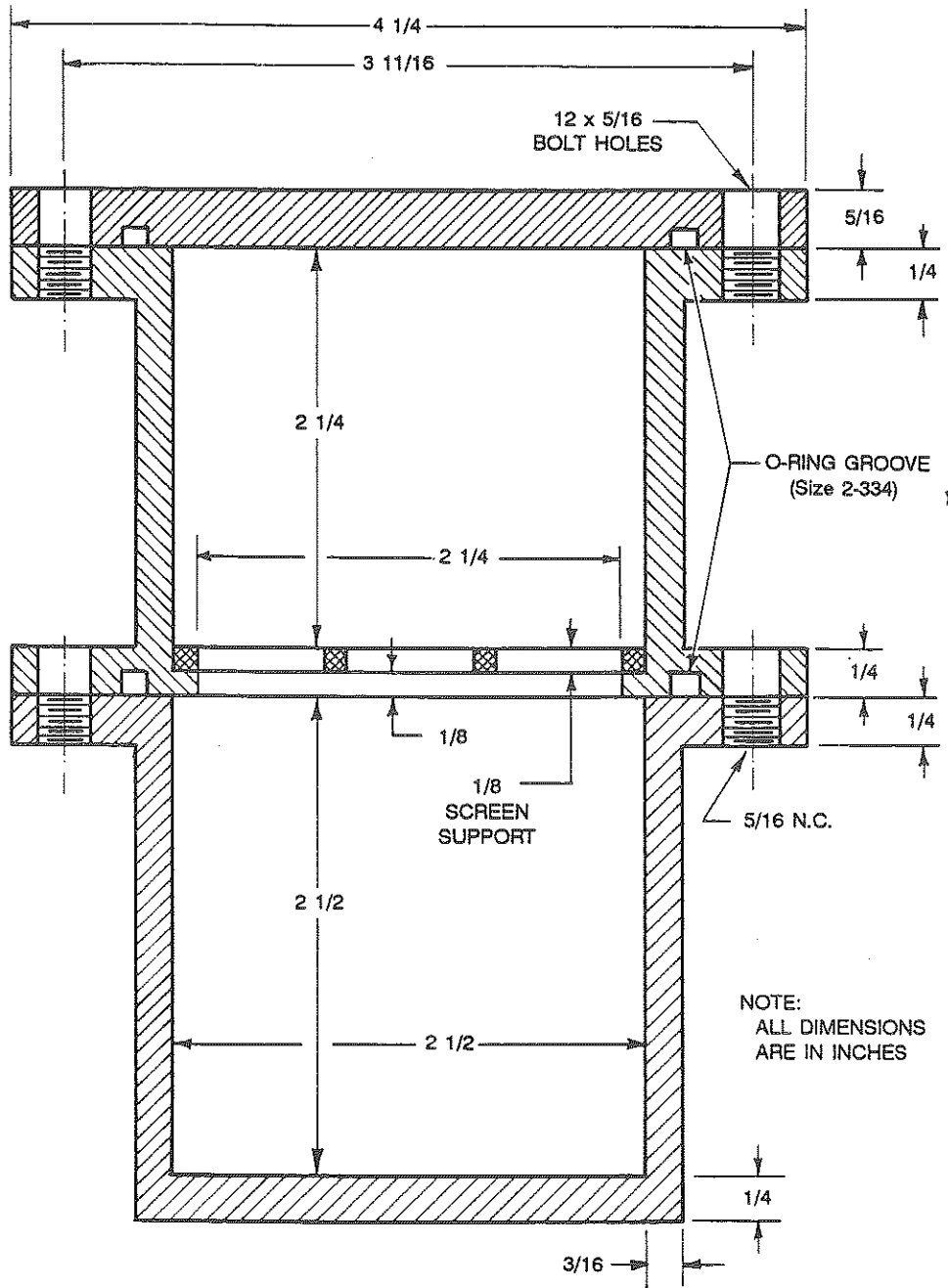

Figure 1. Small experimental extractor - stainless steel.

The initial approach was to investigate the use of supercritical fluid extraction (SFE) since it has been found that fluids at these conditions greatly increase the solubility of many non-volatile materials; increases of several orders of magnitude are common (1, 2). Therefore, compounds which at (or near) ambient conditions are not effective solvents for bitumen may be effective at supercritical conditions.

DISCUSSION OF RESULTS AND PROCEDURE

Preliminary Experiments

The preliminary experiments were run using a small, exploratory sized, stainless steel extractor which consisted of a lid, and cylindrical asphalt pavement and solvent sections (Fig. 1). Each section was machined from a single piece of steel, had a volume of about 200 cc, was grooved for viton o-rings and flanged for bolts.

The basic principle of the SFE experiment was that an asphalt pavement sample (100 to 150 g), supported on a stainless steel screen, and sufficient solvent to produce supercritical densities were placed in the extractor, heated to the critical point or above, cooled, and the extent of extraction determined either by weighing the dried aggregate (the difference method) or by weighing the bitumen after solvent removal (the direct method).

The data are listed in Table 1. It was found that SFE was not practical because the heating times in the oven were too long for those solvents that were effective, cyclopentane and cyclohexane. The MSDS for cyclohexane is given in the Appendix. Of the solvents investigated, carbon dioxide was poorest with no evidence of extraction while n-pentane, although somewhat effective, generally gave low yields of bitumen. In addition, the critical temperature of cyclohexane was too high (280 C) for the o-rings and there was some evidence of bitumen pyrolysis above 280 C. Finally, the screen that was available with the smallest holes (10 microns) still let some fines through, while filter paper at these conditions showed some charring. Thus, it appears that the use of filter paper and lower temperatures are necessary.

These observations led to the investigation of the subcritical procedure which proved to be as effective as SFE in the small extractor; the data are listed in Table 2. The next step was to start the experiments in the large extractor as described in the following section.

Experiments Using the Large Extractor

The large, stainless steel extractor, which can be manufactured for about \$990 (Ronningen-Petter Co.), has the same configuration as the small unit with the sample and solvent sections having volumes of about 1450 and 2300 cc, respectively. Figure 2 illustrates the cross-sectional view and Figure 3 shows the unit disassembled. Figure 2 incorporates

TABLE 1
RESULTS OF SUPERCRITICAL EXTRACTION IN THE SMALL EXTRACTOR

Solvent	Sample Weight, g	Temperature, C ¹	Heating Time, hours ¹	Sample Weight Loss, g	Weight of Solids in Extract, g	Bitumen Extracted, Percent	
						Difference	Direct
<u>Amoco Oil Co. - Top Course 5.5% Bitumen</u>							
CO ₂	151	36	1.5	0	0	—	—
	151	36	2.5	0	0	—	—
n-Pentane	151	200-220	2	6.1	—	4.0	—
	168.8	205-210	4	6.9	7.2	4.1	4.3
	117.9	220	6	5.7	5.6	4.8	4.7 ²
	90.7	210	6	4.7	4.7	5.2	5.2 ²
	100.6	215-225	3.5	—	6.6	—	6.6 ²
	98.1	220	3.7	—	5.2	—	5.3
Cyclopentane	111.2	220	5	—	5.2	—	4.7
	161.4	250	5	—	8.7	—	5.4
	125.1	245	5	—	6.3	—	5.0
Cyclohexane	112.1	250	5.5	—	6.6	—	5.9
	105.1	290	5.5	—	6.3	—	6.0 ²
<u>Amoco Oil Co. - Leveling Course 5.3% Bitumen</u>							
Cyclopentane	132.8	250	6.5	—	6.5	—	4.9
	100.3	245	5	—	5.4	—	5.4
	106.6	250	5	—	5.3	—	5.0
	120.7	250	3.5	—	6.3	—	5.2
	85.2	250	3.5	—	4.6	—	5.4 ²
	108.1	245	3.5	6.6	6.3	6.1	5.8

¹ All extractions were heated in the oven, thus the samples were not at the oven temperature for the times given.

² These extractions showed significant amounts of fines passing through the screens used. It is probable that even the 10 μ screen allows the passage of too many fines, thus filter paper is necessary as used later.

TABLE 2
RESULTS OF SUBCRITICAL EXTRACTION IN THE SMALL EXTRACTOR
(Solvent - Cyclohexane/Asphalt - Leveling Course 5.3% Bitumen)

Sample Weight, g	Temperature, C ¹	Heating Time, hours ¹	Sample Weight Loss, g	Weight of Solids in Extract, g	Bitumen Extracted, Percent	
					Difference	Direct
92.4	240	4	5.3	5.1	5.7	5.5
104.4	250	4	6.3	5.8	6.0	5.6
109.2	250	2	6.4	6.1	5.8	5.6
109.4	250	2	5.4	5.0	4.9	4.6
90.9	250	2	5.2	4.6	5.7	5.1
109.6	240	2	6.8	6.2	6.2	5.7
100.2	240	4	5.7	5.9	5.7	5.9
102.6	245	5	5.6	5.4	5.5	5.3
109.2	240	4	6.0	5.7	5.5	5.2

¹ All extractions were heated in the oven, thus the samples were not at the oven temperature for the times given.

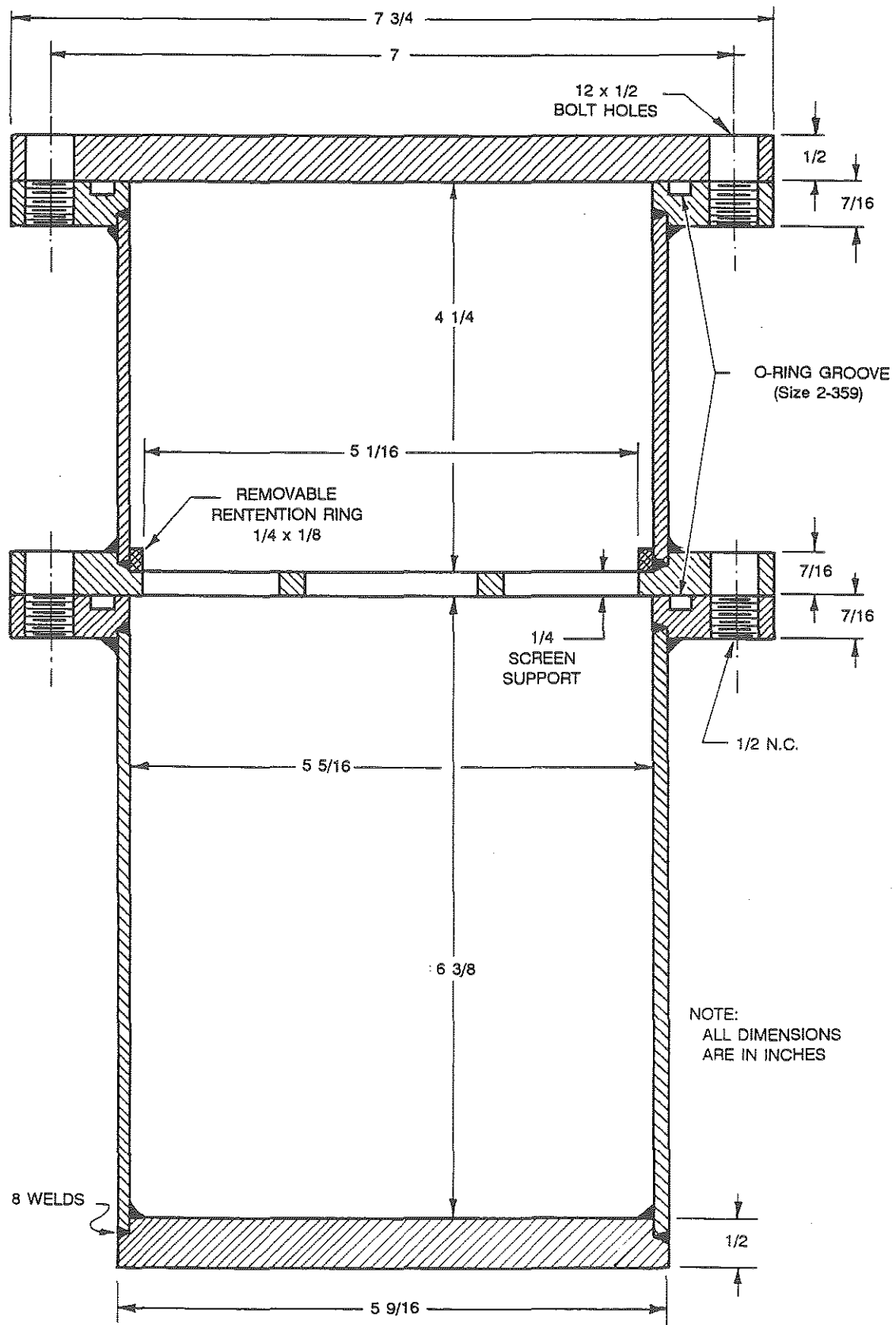

Figure 2. 316-L stainless steel extractor.

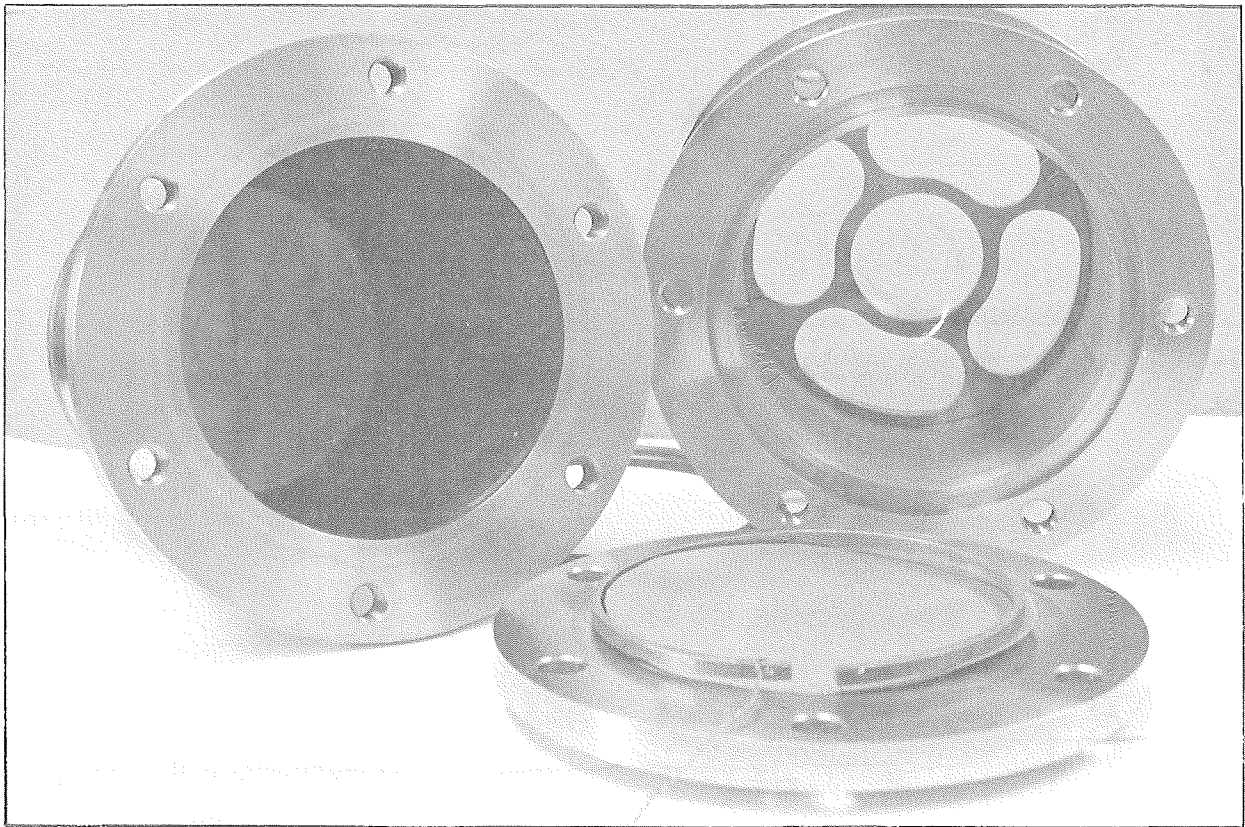

Figure 3. Extractor disassembled.

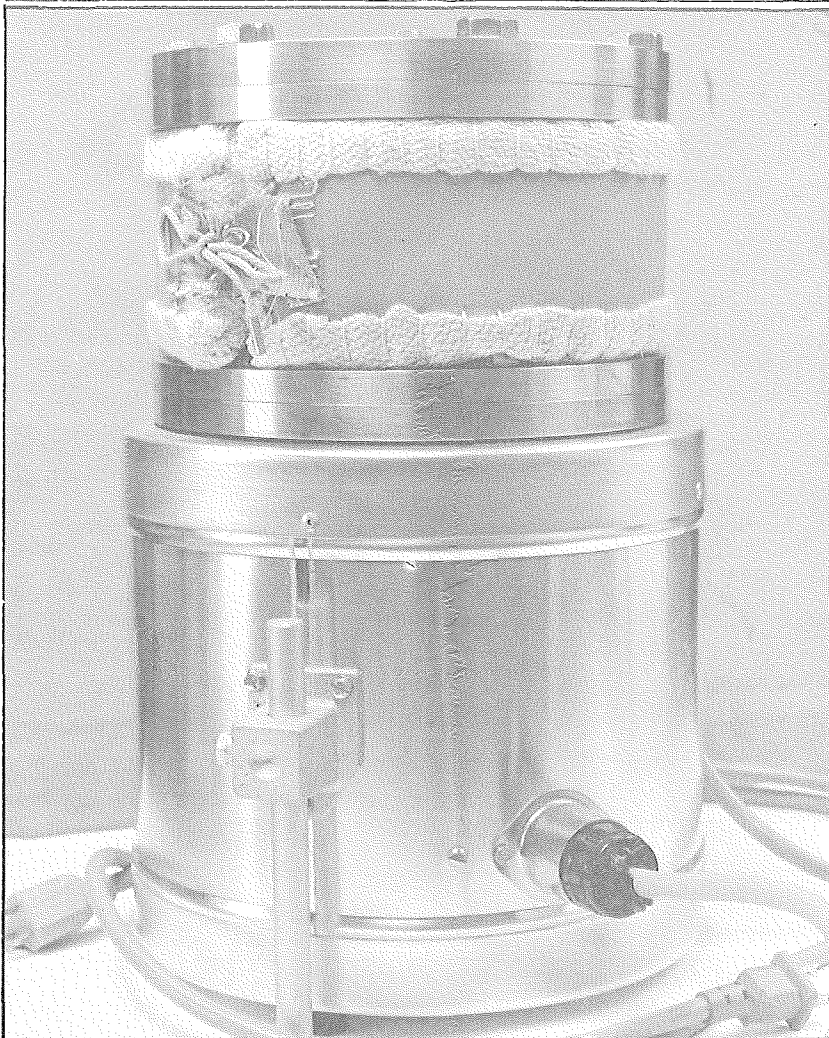

Figure 4. Extractor plus Glas-Col heaters.

two small modifications to the current prototype unit to simplify the operation of the extractor. These modifications are, (a) making the screen support part of the bottom flange of the top section thus permanently welding it into place, and (b) moving one o-ring groove to the bottom section flange. The principle of the procedure is that the solvent (cyclohexane) is heated to 40 to 50 C below its critical temperature which causes it to expand sufficiently to immerse the sample in hot solvent under pressure (about 25 to 30 atm). The bottom section is then cooled causing solvent contraction bringing most of the bitumen with it into the lower section. Washes with ambient solvent, which are vacuum filtered, complete the extraction. The aggregate is dried and weighed and, when necessary as a check on the material balance, the solvent can be distilled from the extract plus washings to get a direct measure of bitumen content. The recovered bitumen can, at least in theory, be used for a penetration test (this point will be elaborated on later).

It is possible to use the 70 percent cyclopentane mixture (minimum of 70 percent cyclopentane plus other low boiling hydrocarbons) as the solvent since it is cost competitive with cyclohexane; pure cyclopentane is about a factor of ten higher in price. However, it is not quite as good a solvent, has a lower flash point and is more difficult to filter.

The advantage of the subcritical extraction procedure (SBE) over SFE is that some surfaces (e.g., the lid and flanges) can be relatively cool without invalidating the procedure since the solvent is as both liquid and vapor. Thus the heating could be accomplished much more quickly using Glas-Col heaters (total cost of both heaters about \$300), which provide more rapid heat transfer to the extractor than an oven; Figure 4 shows the unit with heaters. SFE requires that all surfaces be at least at the critical temperature and also involves higher pressures. In addition, it was found that the same filter paper that is currently in use (No. 627-85 Eaton-Dikeman) could be used with SBE since the temperatures and heating times were lower than with SFE. A 700 mesh, stainless steel screen was used to support the asphalt sample. Details of the procedure will be given in the next section.

The results of the extractions are given in Table 3. In addition to the percent bitumen determinations, some samples of extract, after solvent removal, were submitted to MDOT for recovered penetration tests. Our results are compared to those obtained by MDOT from weight loss after extraction using TCE (the ranges of their percent bitumen results are reported). It can be seen that the percent bitumen results from both procedures are quite comparable.

An examination of the penetration test results indicates that extracts from our procedure are significantly harder than those obtained by MDOT. This may be due to the high temperatures to which the bitumen was exposed during our extraction, since the maximum temperature during distillation of the solvent, run in an inert atmosphere of nitrogen or argon, was about the same (160 to 165 C) for both procedures (although a longer time was

TABLE 3
RESULTS OF SUBCRITICAL EXTRACTION IN THE LARGE EXTRACTOR
(Glas-Col Heaters)

Asphalt Sample		Bitumen, ¹ Percent		Fines, ² Percent	Recovered Penetration, dmm		Heating Time, minutes
MDOT NO.	Weight, g	MDOT	WMU		MDOT	WMU	
3829	1491.2	5.3/5.9	5.7	—	55	60	130
3114	1524.8	6.5/6.9	6.9	—	185	177	130
4044	1420.3	5.5/5.9	6.1	—	55	54	120
3817	1327.9	6.2	6.1	—	62	—	120
3588	1468.7	5.1/5.3	5.3	—	58	67	120
4248	1279.4	5.6/6.0	5.9	—	108	148	120
3977	1397.7	5.3/5.4	5.5	—	134	—	120
3979	1483.1	5.5/5.6	5.7	—	165	118	120
3112	1558.6	6.6/6.9	7.1	2.3	192	79	115
4248	1038.3	5.6/6.0	6.4	3.3	108	44	105
3978	1395.8	5.6/5.8	5.8	2.4	141	87	105
3979	1453.8	5.5/5.6	5.6	2.3	165	108	105
3978	1424.5	5.6/5.8	5.7	3.3	141	68	90
5324	1518.6	5.0	5.3	3.8	70	68	90
5004	1450.5	5.3	5.4	5.3	69	52	75
5337	1501.8	5.1	5.7	—	73	—	75
5337	1431.2	5.1	5.3	—	73	—	75
5323	1521.6	4.8	5.1	4.2	63	51	75

¹ These reported values were determined by difference only, direct measurement of bitumen was impractical because of distillation times necessary for complete solvent removal. The MDOT values are their ranges when reported.

² These are % fines in recovered bitumen.

needed to remove the cyclohexane because of the larger quantity of solvent needed). However, the validity of the recovered penetration tests must be questioned. In most, if not all, of the cyclohexane distillations some light, colorless, oils of low volatility were observed separating from the bitumen before all the solvent had been removed, presumably leaving a harder residue in the pot. Since the normal boiling point of cyclohexane is 7 C below that of TCE and 6 C above that of 1,1,1-trichloroethane it would be difficult, if not impossible, to remove all of those chlorinated solvents without some oils separating also. It appears that a determination of the causes of bitumen hardening during extraction would be a research project in itself.

Procedures

The following is an outline of our procedure, Part A is the extraction step to determine percent bitumen by difference, Part B is the distillation step to recover the bitumen for the penetration test and the solvent for recycling if needed.

Part A - The entire extractor is made of 316 stainless steel. The filter paper and 700 mesh screen are placed, in that order, on the grill at the bottom of the top section followed by a retaining ring and the asphalt sample (up to 1.75 kg with packing in the unit described). The lid is bolted closed, about 1800 ml of cyclohexane is placed in the bottom section and the sections bolted together; viton o-rings are used to make the seals. The extractor is placed in a Glas-Col heater (3 l beaker size) which surrounds the solvent section to the flange, a custom made Glas-Col jacket is placed around the sample section and both are heated for 75 minutes at 115 V. The unit is separated from the heaters and air cooled (with a stream of compressed air if available) for 40 minutes then water cooled (bottom first) for about 20 to 30 minutes until warm to the touch. The air cooling prevents too large a pressure differential from developing between sections by slowing the initial rate of temperature decrease. Following the cooling the extractor is opened, the solvent plus extract decanted into a 4 l polyethylene beaker and discarded or set aside for Part B if bitumen and/or solvent recovery are needed. The retaining ring is removed and the aggregate removed to another 4 l polyethylene beaker. The extractor parts, screen and filter paper are rinsed with ambient solvent and the solids are all washed into the beaker. The aggregate washing is filtered using a Buchner funnel and stranded coarse filter paper, then the aggregate is repeatedly rinsed with solvent until the filtrate is a light straw color (about four or five more washings of about 350 ml each). The filtrate can be saved for Part B or discarded. After the washings with cyclohexane, two additional washings with n-pentane are made so that the aggregate can be dried more rapidly; the pentane washes are discarded. During the final washing the aggregate is transferred to a 3 l pyrex beaker and is combined with the solid on the filter paper from the Buchner funnel for drying with warming in the Glas-Col heater. An alternate drying procedure is to spread the entire aggregate on smooth heavy paper after the pentane wash and allow it to dry at ambient temperature with occasional stirring (about 20 to 30 minutes), then return it to the beaker. The dried aggregate in the beaker and that trapped on the extractor screen and filter paper is weighed to calculate the percent bitumen by difference. Part A requires 3.5 to 4 hours to complete. However, it may be possible to reduce this time by 0.5 hours after more experience with the procedure.

Part B - The extract (about 1.8 l) can be distilled in an inert atmosphere to separate the bitumen from the solvent for the penetration test. The cyclohexane washings (about 3 l) can be distilled also and the distillates combined to recover the solvent for reuse or to be recycled. This part can be time consuming and is not necessary if only the bitumen content and aggregate size distribution are needed. The solvent - bitumen mixtures can be disposed of by combining with the asphalt pavement batches since they are below the autoignition temperature of cyclohexane if recovery is not needed. To determine the bitumen by direct measurement, the distillation step was much too slow for practical applications since the extract and washings had to be combined and the last bit of solvent was very difficult to remove from the flask necks and standard taper joints.

CONCLUSIONS

A new method of extracting bitumen from asphalt pavement mixtures has been developed which gives bitumen contents essentially the same as those obtained by the currently used method. The preferred solvent is cyclohexane (although cyclopentane may be used) at high temperatures and pressures. The new method has met a majority of the program objectives:

(a) It employs equipment less costly than that currently used in the centrifuge procedure.

(b) It uses a solvent that does not have the disposal problem that chlorinated solvents have, nor is it the health hazard to exposed personnel that chlorinated and aromatic solvents are.

(c) The solvent is less expensive than Bioact and is as volatile as chlorinated solvents, thus allowing separation from the bitumen for solvent recovery and further testing.

(d) The procedure is not too complex for non-professional personnel to perform.

The objective that the method would be as fast as the centrifuge method using chlorinated solvents was not met, although it is about as fast as the Bioact procedure. Finally, the solvent can be a fire hazard unless reasonable precautions are taken. However, it should be noted that this hazard would exist for every common solvent for bitumen that is not chlorinated and is volatile enough to be separated from the extract, and thus cannot be avoided within those constraints.

REFERENCES

1. Williams, D. F., Chem. Eng. Sci., 36, 1769 (1981).
2. Gangoli, N. and Thodos, G., Ind. Eng. Chem: Prod. Res. Dev., 16, No. 3, 208 (1977).

APPENDIX
MSDS for Cyclohexane

DATE: 10/05/89
INDEX: 05892650226

ACCT: 876320-01
CAT NO: C5564

PAGE: 1
PO NBR: 08100-P

CYCLOHEXANE
CYCLOHEXANE
CYCLOHEXANE

MATERIAL SAFETY DATA SHEET

FISHER SCIENTIFIC
CHEMICAL DIVISION
1 REAGENT LANE
FAIR LAWN NJ 07410
(201) 796-7100

EMERGENCY CONTACTS:
GASTON L. PILLORI: (201) 796-7100
AFTER BUSINESS HOURS; HOLIDAYS:
(201) 796-7523
CHEMTREC ASSISTANCE: (800) 429-9300

THE INFORMATION BELOW IS BELIEVED TO BE ACCURATE AND REPRESENTS THE BEST INFORMATION CURRENTLY AVAILABLE TO US. HOWEVER, WE MAKE NO WARRANTY OF MERCHANTABILITY OR ANY OTHER WARRANTY, EXPRESS OR IMPLIED, WITH RESPECT TO SUCH INFORMATION, AND WE ASSUME NO LIABILITY RESULTING FROM ITS USE. USERS SHOULD MAKE THEIR OWN INVESTIGATIONS TO DETERMINE THE SUITABILITY OF THE INFORMATION FOR THEIR PARTICULAR PURPOSES.

SUBSTANCE IDENTIFICATION

SUBSTANCE: ***CYCLOHEXANE***

CAS-NUMBER 110-82-7

TRADE NAMES/SYNONYMS:

HEXAHYDROBENZENE; HEXAMETHYLENE; HEXANAPHTHENE; BENZENE HEXAHYDRIDE;
RCRA U056; STCC 4908132; UN 1145; C-552; C-553; C-555; C-620; C-2093; C6H12;
ACCU5870

CHEMICAL FAMILY:
HYDROCARBON, ALICYCLIC

MOLECULAR FORMULA: C6-H12

MOLECULAR WEIGHT: 84.18

CERCLA RATINGS (SCALE 0-3): HEALTH=2 FIRE=3 REACTIVITY=0 PERSISTENCE=0
NFPA RATINGS (SCALE 0-4): HEALTH=1 FIRE=3 REACTIVITY=0

COMPONENTS AND CONTAMINANTS

COMPONENT: CYCLOHEXANE

PERCENT: 100

OTHER CONTAMINANTS: NONE

EXPOSURE LIMITS:

CYCLOHEXANE:
300 PPM (1050 MG/M3) OSHA TWA
300 PPM (1050 MG/M3) ACGIH TWA

1000 POUNDS CERCLA SECTION 103 REPORTABLE QUANTITY
SUBJECT TO SARA SECTION 313 ANNUAL TOXIC CHEMICAL RELEASE REPORTING

PHYSICAL DATA

DESCRIPTION: COLORLESS LIQUID WITH A MILD, SWEET ODOR RESEMBLING CHLOROFORM
OR BENZENE. BOILING POINT: 179 F (81 C) MELTING POINT: 44 F (7 C)

SPECIFIC GRAVITY: 0.779 VOLATILITY: 100% VAPOR PRESSURE: 95 MMHG @ 20 C

EVAPORATION RATE: NOT AVAILABLE SOLUBILITY IN WATER: <0.01%

ODOR THRESHOLD: 0.41 PPM VAPOR DENSITY: 2.90

SOLVENT SOLUBILITY: SOLUBLE IN METHANOL, ETHANOL, ETHER, ACETONE, BENZENE,
LIGROIN, CARBON TETRACHLORIDE

VISCOSITY: 0.914 CP @ 72 F

FIRE AND EXPLOSION DATA

FIRE AND EXPLOSION HAZARD:
DANGEROUS FIRE HAZARD WHEN EXPOSED TO HEAT OR FLAME.

MODERATE EXPLOSION HAZARD WHEN EXPOSED TO HEAT OR FLAME.

VAPORS ARE HEAVIER THAN AIR AND MAY TRAVEL A CONSIDERABLE DISTANCE TO A SOURCE
OF IGNITION AND FLASH BACK.

VAPOR-AIR MIXTURES ARE EXPLOSIVE ABOVE FLASH POINT.

FLASH POINT: -4 F (-20 C) (CC) UPPER EXPLOSIVE LIMIT: 8.4%

LOWER EXPLOSIVE LIMIT: 1.3% AUTOIGNITION TEMP.: 473 F (245 C)

DATE: 10/05/89
INDEX: 05892650226

ACCT: 876320-01
CAT NO: C5564

PAGE: 2
PO NBR: 08100-P

FLAMMABILITY CLASS(OSHA): IB

FIREFIGHTING MEDIA:

DRY CHEMICAL, CARBON DIOXIDE, HALON, WATER SPRAY OR ALCOHOL FOAM (1987 EMERGENCY RESPONSE GUIDEBOOK, DOT P 5800.4).

FOR LARGER FIRES, USE WATER SPRAY, FOG OR ALCOHOL FOAM (1987 EMERGENCY RESPONSE GUIDEBOOK, DOT P 5800.4).

FIREFIGHTING:

MOVE CONTAINER FROM FIRE AREA IF POSSIBLE. COOL FIRE-EXPOSED CONTAINERS WITH WATER FROM SIDE UNTIL WELL AFTER FIRE IS OUT. STAY AWAY FROM STORAGE TANK ENDS. FOR MASSIVE FIRE IN STORAGE AREA, USE UNMANNED HOSE HOLDER OR MONITOR NOZZLES, ELSE WITHDRAW FROM AREA AND LET FIRE BURN. WITHDRAW IMMEDIATELY IN CASE OF RISING SOUND FROM VENTING SAFETY DEVICE OR ANY DISCOLORATION OF STORAGE TANK DUE TO FIRE (1987 EMERGENCY RESPONSE GUIDEBOOK, DOT P 5800.4, GUIDE PAGE 26).

EXTINGUISH ONLY IF FLOW CAN BE STOPPED. USE FLOODING AMOUNTS OF WATER AS FOG. SOLID STREAMS MAY SPREAD FIRE. COOL CONTAINERS WITH FLOODING AMOUNTS OF WATER; APPLY FROM AS FAR A DISTANCE AS POSSIBLE. AVOID BREATHING TOXIC VAPORS. KEEP UPWIND. IF FIRE IS UNCONTROLLABLE EVACUATE TO A DISTANCE OF 1500 FEET. CONSIDER EVACUATION OF DOWNWIND AREA IF MATERIAL IS LEAKING.

WATER MAY BE INEFFECTIVE (NFPA FIRE PROTECTION GUIDE ON HAZARDOUS MATERIALS, EIGHTH EDITION).

TRANSPORTATION DATA

DEPARTMENT OF TRANSPORTATION HAZARD CLASSIFICATION 49CFR172.101:
FLAMMABLE LIQUID

DEPARTMENT OF TRANSPORTATION LABELING REQUIREMENTS 49CFR172.101 AND 172.402:
FLAMMABLE LIQUID

DEPARTMENT OF TRANSPORTATION PACKAGING REQUIREMENTS: 49CFR173.119
EXCEPTIONS: 49CFR173.118

TOXICITY

CYCLOHEXANE:

IRRITATION DATA: 1548 MG/2 DAYS-INTERMITTENT SKIN-RABBIT IRRITATION
TOXICITY DATA: 12,705 MG/KG ORAL-RAT LD50; 813 MG/KG ORAL-MOUSE LD50;
5500 MG/KG ORAL-RABBIT LDLO; 77 MG/KG INTRAVENOUS-RABBIT LDLO; MUTAGENIC DATA (RTECS).

CARCINOGEN STATUS: NONE.

LOCAL EFFECTS: IRRITANT-EYES, SKIN AND MUCOUS MEMBRANES.

ACUTE TOXICITY LEVEL: SLIGHTLY TOXIC BY INGESTION.

TARGET EFFECTS: CENTRAL NERVOUS SYSTEM DEPRESSANT.

AT INCREASED RISK FROM EXPOSURE: PERSONS WITH A HISTORY OF CHRONIC

RESPIRATORY, LIVER, KIDNEY, OR SKIN DISEASE.

ADDITIONAL DATA: THE USE OF ALCOHOLIC BEVERAGES MAY ENHANCE THE TOXIC EFFECTS.

HEALTH EFFECTS AND FIRST AID

INHALATION:

CYCLOHEXANE:

IRRITANT/NARCOTIC. 10,000 PPM IMMEDIATELY DANGEROUS TO LIFE OR HEALTH.

ACUTE EXPOSURE- INHALATION OF LOW CONCENTRATIONS MAY CAUSE IRRITATION OF THE EYES, NOSE, AND RESPIRATORY TRACT. EXPOSURE TO CONCENTRATIONS ABOVE 12,000 PPM MAY CAUSE CENTRAL NERVOUS SYSTEM DEPRESSION WITH EXCITEMENT, HEADACHE, DIZZINESS, DULLNESS, NAUSEA, VOMITING, NARCOSIS, COMA, AND POSSIBLE DEATH DUE TO RESPIRATORY FAILURE. LETHAL CONCENTRATIONS TO ANIMALS CAUSED GENERALIZED VASCULAR DAMAGE WITH SEVERE DEGENERATIVE CHANGES IN THE HEART, LUNGS, LIVER, KIDNEYS, AND BRAIN.

CHRONIC EXPOSURE- REPEATED OR PROLONGED EXPOSURE TO CONCENTRATIONS ABOVE 300 PPM MAY PRODUCE MILD IRRITATION OF THE EYES AND UPPER RESPIRATORY TRACT. REPEATED EXPOSURES CAUSED MICROSCOPIC CHANGES IN THE LIVER AND KIDNEYS, LETHARGY, LIGHT NARCOSIS, DIARRHEA, AND SOME DEATHS IN ANIMALS.

FIRST AID- REMOVE FROM EXPOSURE AREA TO FRESH AIR IMMEDIATELY. IF BREATHING HAS STOPPED, PERFORM ARTIFICIAL RESPIRATION. KEEP PERSON WARM AND AT REST. TREAT SYMPTOMATICALLY AND SUPPORTIVELY. GET MEDICAL ATTENTION IMMEDIATELY.

SKIN CONTACT:

CYCLOHEXANE:

IRRITANT.

ACUTE EXPOSURE- MAY CAUSE IRRITATION WITH REDNESS AND DRYNESS. MASSIVE APPLICATIONS TO RABBIT SKIN HAVE PRODUCED MICROSCOPIC CHANGES IN THE LIVER AND KIDNEYS.

CHRONIC EXPOSURE- REPEATED OR PROLONGED CONTACT WITH LIQUID CYCLOHEXANE MAY CAUSE IRRITATION, DEFATTING OF THE SKIN, AND A DRY, SCALY, FISSURED DERMATITIS.

FIRST AID- REMOVE CONTAMINATED CLOTHING AND SHOES IMMEDIATELY. WASH AFFECTED AREA WITH SOAP OR MILD DETERGENT AND LARGE AMOUNTS OF WATER UNTIL NO

DATE: 10/05/89
INDEX: 05892650226

ACCT: 876320-01
CAT NO: C5564

PO NBR: 08100-P

EVIDENCE OF CHEMICAL REMAINS (APPROXIMATELY 15-20 MINUTES). GET MEDICAL ATTENTION IMMEDIATELY.

EYE CONTACT:
CYCLOHEXANE:
IRRITANT.

ACUTE EXPOSURE- CYCLOHEXANE HAS NO NOTABLE IRRITANT EFFECTS ON HUMAN EYES, NOR ON RABBIT EYES TESTED BY EXPOSURE TO CONCENTRATIONS OF 11 MG/M3. CONTACT WITH LIQUID OR HIGH VAPOR CONCENTRATIONS MAY CAUSE IRRITATION, WITH TEARING AND REDNESS, AND A MILD CONJUNCTIVITIS.
CHRONIC EXPOSURE- REPEATED OR PROLONGED EXPOSURE MAY CAUSE CONJUNCTIVITIS.

FIRST AID- WASH EYES IMMEDIATELY WITH LARGE AMOUNTS OF WATER OR NORMAL SALINE, OCCASIONALLY LIFTING UPPER AND LOWER LIDS, UNTIL NO EVIDENCE OF CHEMICAL REMAINS (APPROXIMATELY 15-20 MINUTES). GET MEDICAL ATTENTION IMMEDIATELY.

INGESTION:
CYCLOHEXANE:
NARCOTIC.

ACUTE EXPOSURE- INGESTION OF CYCLOHEXANE MAY CAUSE SYMPTOMS OF CENTRAL NERVOUS SYSTEM DEPRESSION WITH EXCITEMENT, HEADACHE, DIZZINESS, DULLNESS, NAUSEA, VOMITING, NARCOSIS, COMA, AND POSSIBLE DEATH DUE TO RESPIRATORY FAILURE. ASPIRATION MAY CAUSE CHEMICAL PNEUMONITIS. LETHAL DOSES TO ANIMALS CAUSED GENERALIZED VASCULAR DAMAGE WITH SEVERE DEGENERATIVE CHANGES IN THE HEART, LUNGS, LIVER, KIDNEYS, AND BRAIN.
CHRONIC EXPOSURE- NO DATA AVAILABLE.

FIRST AID- EXTREME CARE MUST BE USED TO PREVENT ASPIRATION. USE GASTRIC LAVAGE WITH ACTIVATED CHARCOAL AND A CUFFED ENDOTRACHEAL TUBE WITHIN 15 MINUTES. IN THE ABSENCE OF DEPRESSION OR CONVULSIONS OR IMPAIRED GAG REFLEX, IPECAC EMESIS CAN BE DONE. WHEN VOMITING BEGINS, KEEP HEAD LOWER THAN HIPS TO PREVENT ASPIRATION. AFTER VOMITING STOPS, GIVE 30-60 MILLILITERS OF FLEET'S PHOSPHO-SODA DILUTED 1:4 IN WATER. MAINTAIN AIRWAY, BLOOD PRESSURE AND RESPIRATION. (DREISBACH, HANDBOOK OF POISONING, 11TH ED.) TREATMENT MUST BE ADMINISTERED BY QUALIFIED MEDICAL PERSONNEL. GET MEDICAL ATTENTION.

ANTIDOTE:
NO SPECIFIC ANTIDOTE. TREAT SYMPTOMATICALLY AND SUPPORTIVELY.

REACTIVITY

REACTIVITY:
STABLE UNDER NORMAL TEMPERATURES AND PRESSURES.

INCOMPATIBILITIES:
CYCLOHEXANE:
NITROGEN DIOXIDE (LIQUID): POSSIBLE EXPLOSION.
OXIDIZERS (STRONG): FIRE AND EXPLOSION HAZARD.
PLASTICS, RUBBER, COATINGS: MAY BE ATTACKED.

DECOMPOSITION:
THERMAL DECOMPOSITION PRODUCTS MAY INCLUDE TOXIC OXIDES OF CARBON.

POLYMERIZATION:
HAZARDOUS POLYMERIZATION HAS NOT BEEN REPORTED TO OCCUR UNDER NORMAL TEMPERATURES AND PRESSURES.

STORAGE AND DISPOSAL

OBSERVE ALL FEDERAL, STATE AND LOCAL REGULATIONS WHEN STORING OR DISPOSING OF THIS SUBSTANCE. FOR ASSISTANCE, CONTACT THE DISTRICT DIRECTOR OF THE ENVIRONMENTAL PROTECTION AGENCY.

STORAGE

STORE IN ACCORDANCE WITH 29 CFR 1910.106.

BONDING AND GROUNDING: SUBSTANCES WITH LOW ELECTROCONDUCTIVITY, WHICH MAY BE IGNITED BY ELECTROSTATIC SPARKS, SHOULD BE STORED IN CONTAINERS WHICH MEET THE BONDING AND GROUNDING GUIDELINES SPECIFIED IN NFPA 77-1983, RECOMMENDED PRACTICE ON STATIC ELECTRICITY.

STORE AWAY FROM INCOMPATIBLE SUBSTANCES.

DISPOSAL

DISPOSAL MUST BE IN ACCORDANCE WITH STANDARDS APPLICABLE TO GENERATORS OF HAZARDOUS WASTE, 40CFR 262. EPA HAZARDOUS WASTE NUMBER U056.

CONDITIONS TO AVOID

MAY BE IGNITED BY HEAT, SPARKS OR FLAMES. CONTAINER MAY EXPLODE IN HEAT OF FIRE. VAPOR EXPLOSION HAZARD INDOORS, OUTDOORS OR IN SEWERS. RUN-OFF TO

SEWER MAY CREATE FIRE OR EXPLOSION HAZARD.

SPILL AND LEAK PROCEDURES

SOIL SPILL:

DIG A HOLDING AREA SUCH AS A PIT, POND OR LAGOON TO CONTAIN SPILL AND DIKE SURFACE FLOW USING BARRIER OF SOIL, SANDBAGS, FOAMED POLYURETHANE OR FOAMED CONCRETE. ABSORB LIQUID MASS WITH FLY ASH OR CEMENT POWDER.

IMMOBILIZE SPILL WITH UNIVERSAL GELLING AGENT.

REDUCE VAPOR AND FIRE HAZARD WITH FLUOROCARBON WATER FOAM.

AIR SPILL:

KNOCK DOWN VAPORS WITH WATER SPRAY. KEEP UPWIND.

WATER SPILL:

LIMIT SPILL MOTION AND DISPERSION WITH NATURAL BARRIERS OR OIL SPILL CONTROL BOOMS.

APPLY DETERGENTS, SOAPS, ALCOHOLS OR ANOTHER SURFACE ACTIVE AGENT.

APPLY UNIVERSAL GELLING AGENT TO IMMOBILIZE TRAPPED SPILL AND INCREASE EFFICIENCY OF REMOVAL.

USE SUCTION HOSES TO REMOVE TRAPPED SPILL MATERIAL.

USE MECHANICAL DREDGES OR LIFTS TO EXTRACT IMMOBILIZED MASSES OF POLLUTION AND PRECIPITATES.

OCCUPATIONAL SPILL:

SHUT OFF IGNITION SOURCES. STOP LEAK IF YOU CAN DO IT WITHOUT RISK. USE WATER SPRAY TO REDUCE VAPORS. FOR SMALL SPILLS, TAKE UP WITH SAND OR OTHER ABSORBENT MATERIAL AND PLACE INTO CONTAINERS FOR LATER DISPOSAL. FOR LARGER SPILLS, DIKE FAR AHEAD OF SPILL FOR LATER DISPOSAL. NO SMOKING, FLAMES OR FLARES IN HAZARD AREA! KEEP UNNECESSARY PEOPLE AWAY; ISOLATE HAZARD AREA AND DENY ENTRY.

REPORTABLE QUANTITY (RQ): 1000 POUNDS

THE SUPERFUND AMENDMENTS AND REAUTHORIZATION ACT (SARA) SECTION 304 REQUIRES THAT A RELEASE EQUAL TO OR GREATER THAN THE REPORTABLE QUANTITY FOR THIS SUBSTANCE BE IMMEDIATELY REPORTED TO THE LOCAL EMERGENCY PLANNING COMMITTEE AND THE STATE EMERGENCY RESPONSE COMMISSION (40 CFR 355.40). IF THE RELEASE OF THIS SUBSTANCE IS REPORTABLE UNDER CERCLA SECTION 103, THE NATIONAL RESPONSE CENTER MUST BE NOTIFIED IMMEDIATELY AT (800) 424-8802 OR (202) 426-2675 IN THE METROPOLITAN WASHINGTON, D.C. AREA (40 CFR 302.6).

PROTECTIVE EQUIPMENT

VENTILATION:

PROVIDE LOCAL EXHAUST OR GENERAL DILUTION VENTILATION TO MEET PUBLISHED EXPOSURE LIMITS. VENTILATION EQUIPMENT MUST BE EXPLOSION-PROOF.

RESPIRATOR:

THE FOLLOWING RESPIRATORS AND MAXIMUM USE CONCENTRATIONS ARE RECOMMENDATIONS BY THE U. S. DEPARTMENT OF HEALTH AND HUMAN SERVICES, NIOSH POCKET GUIDE TO CHEMICAL HAZARDS OR NIOSH CRITERIA DOCUMENTS; OR DEPARTMENT OF LABOR, 29CFR1910 SUBPART 2.

THE SPECIFIC RESPIRATOR SELECTED MUST BE BASED ON CONTAMINATION LEVELS FOUND IN THE WORK PLACE AND BE JOINTLY APPROVED BY THE NATIONAL INSTITUTE OF OCCUPATIONAL SAFETY AND HEALTH AND THE MINE SAFETY AND HEALTH ADMINISTRATION.

CYCLOHEXANE:

1000 PPM- ANY POWERED AIR-PURIFYING RESPIRATOR WITH ORGANIC VAPOR CARTRIDGE(S).

ANY CHEMICAL CARTRIDGE RESPIRATOR WITH A FULL FACEPIECE AND ORGANIC VAPOR CARTRIDGE(S).

7500 PPM- ANY SUPPLIED-AIR RESPIRATOR OPERATED IN A CONTINUOUS FLOW MODE.

10,000 PPM- ANY AIR-PURIFYING FULL FACEPIECE RESPIRATOR (GAS MASK) WITH A CHIN-STYLE OR FRONT- OR BACK-MOUNTED ORGANIC VAPOR CANISTER.
ANY SELF-CONTAINED BREATHING APPARATUS WITH A FULL FACEPIECE.
ANY SUPPLIED-AIR RESPIRATOR WITH A FULL FACEPIECE.

ESCAPE- ANY AIR-PURIFYING FULL FACEPIECE RESPIRATOR (GAS MASK) WITH A CHIN-STYLE OR FRONT- OR BACK-MOUNTED ORGANIC VAPOR CANISTER.
ANY APPROPRIATE ESCAPE-TYPE SELF-CONTAINED BREATHING APPARATUS.

FOR FIREFIGHTING AND OTHER IMMEDIATELY DANGEROUS TO LIFE OR HEALTH CONDITIONS:

SELF-CONTAINED BREATHING APPARATUS WITH FULL FACEPIECE OPERATED IN PRESSURE DEMAND OR OTHER POSITIVE PRESSURE MODE.

SUPPLIED-AIR RESPIRATOR WITH FULL FACEPIECE AND OPERATED IN PRESSURE-DEMAND OR OTHER POSITIVE PRESSURE MODE IN COMBINATION WITH AN AUXILIARY SELF-CONTAINED BREATHING APPARATUS OPERATED IN PRESSURE-DEMAND OR OTHER

DATE: 10/05/89
INDEX: 05892650226

ACCT: 876320-01
CAT NO: C5564

PAGE: 5
PO NBR: 08100-P

POSITIVE PRESSURE MODE.

CLOTHING:
EMPLOYEE MUST WEAR APPROPRIATE PROTECTIVE (IMPERVIOUS) CLOTHING AND EQUIPMENT TO PREVENT REPEATED OR PROLONGED SKIN CONTACT WITH THIS SUBSTANCE.

GLOVES:
EMPLOYEE MUST WEAR APPROPRIATE PROTECTIVE GLOVES TO PREVENT CONTACT WITH THIS SUBSTANCE.

EYE PROTECTION:
EMPLOYEE MUST WEAR SPLASH-PROOF OR DUST-RESISTANT SAFETY GOGGLES TO PREVENT EYE CONTACT WITH THIS SUBSTANCE. CONTACT LENSES SHOULD NOT BE WORN.

AUTHORIZED - FISHER SCIENTIFIC GROUP, INC.
CREATION DATE: 10/02/84 REVISION DATE: 03/23/89

-ADDITIONAL INFORMATION-

THE INFORMATION BELOW IS BELIEVED TO BE ACCURATE AND REPRESENTS THE BEST INFORMATION CURRENTLY AVAILABLE TO US. HOWEVER, WE MAKE NO WARRANTY OF MERCHANTABILITY OR ANY OTHER WARRANTY, EXPRESS OR IMPLIED, WITH RESPECT TO SUCH INFORMATION, AND WE ASSUME NO LIABILITY RESULTING FROM ITS USE. USERS SHOULD MAKE THEIR OWN INVESTIGATIONS TO DETERMINE THE SUITABILITY OF THE INFORMATION FOR THEIR PARTICULAR PURPOSES.