

- NOTES:**
- 1) Lead-in slot may be on either near or far side of loop approach as directed by the Engineer.
 - 2) Two loops maximum allowed per saw cut from loop to curb.
 - 3) 3 turns required for loops equal to or greater than 6'x10'.
 - 4) 4 turns required for loops less than 6'x10'.
 - 5) Refer to contract documents for high pressure washing of saw cuts and removal of debris.

NOT TO SCALE File: PW:RD/TR/Signals/WC SD/Final Rev. 10/21/14

 PREPARED BY TRAFFIC AND SAFETY	_____ ENGINEER OF DELIVERY	MICHIGAN DEPARTMENT OF TRANSPORTATION BUREAU OF HIGHWAYS DELIVERY STANDARD PLAN FOR TRAFFIC LOOPS		
	_____ ENGINEER OF DEVELOPMENT		_____ PLAN DATE	WC-170-A
DRAWN BY: CHECKED BY:	(SPECIAL DETAIL) FHWA APPROVAL DATE			

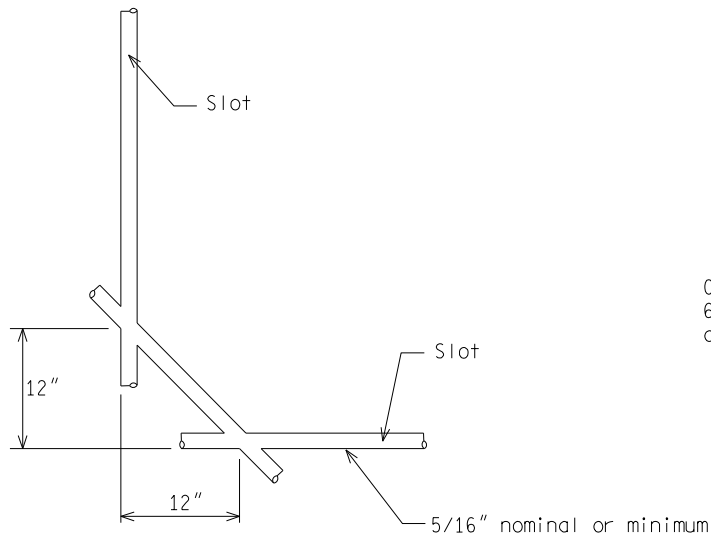

DETAIL "A"
CORNER CUTS

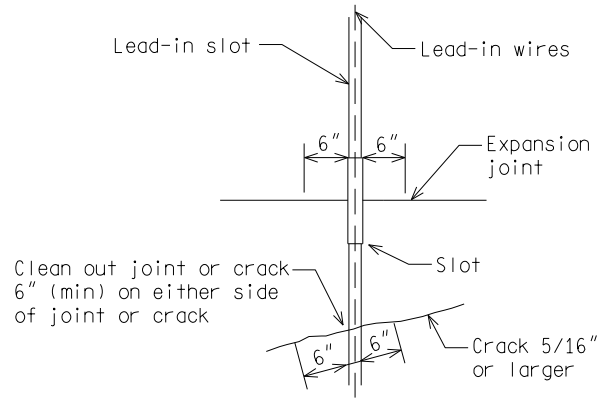

DETAIL "B"
EXPANSION JOINT CUTS

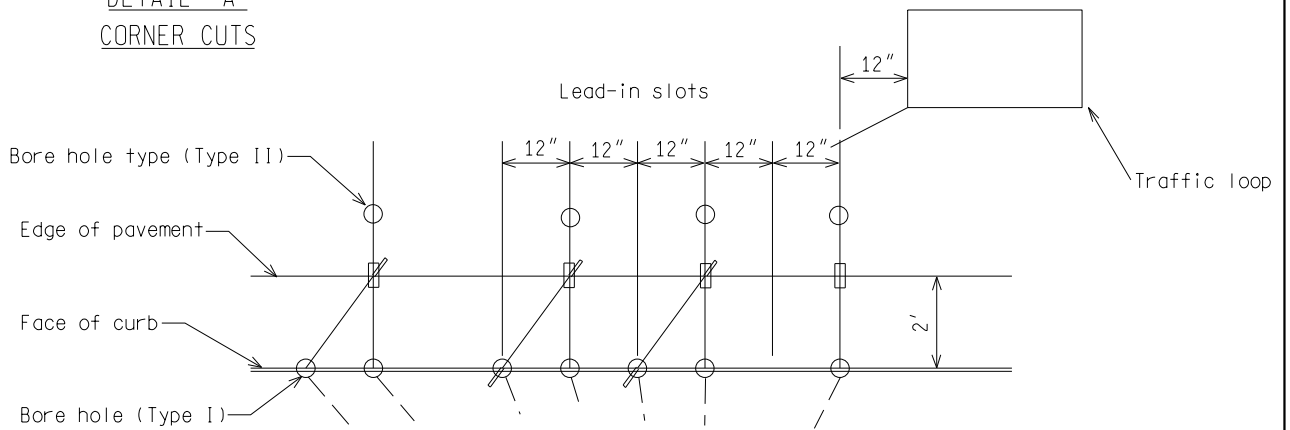

DETAIL "C"
TERMINATION OF LEAD-IN SLOTS

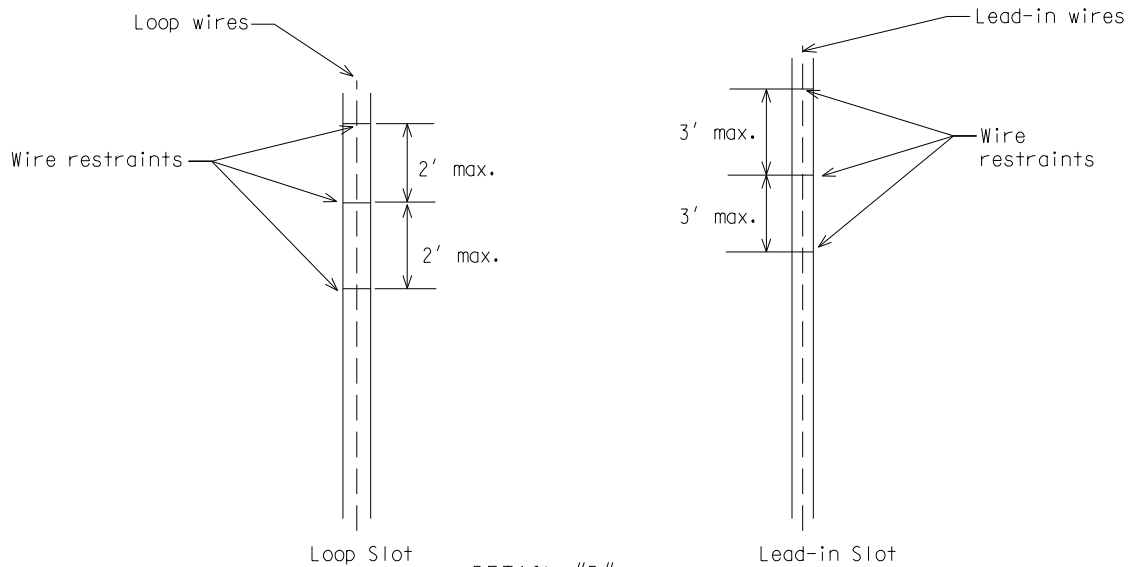

DETAIL "D"
WIRE RESTRAINTS

NOT TO SCALE

MICHIGAN DEPARTMENT OF TRANSPORTATION
BUREAU OF HIGHWAYS DELIVERY STANDARD PLAN

(SPECIAL DETAIL)
FHWA APPROVAL DATE

PLAN DATE

WC-170-A

SHEET
2 of 4

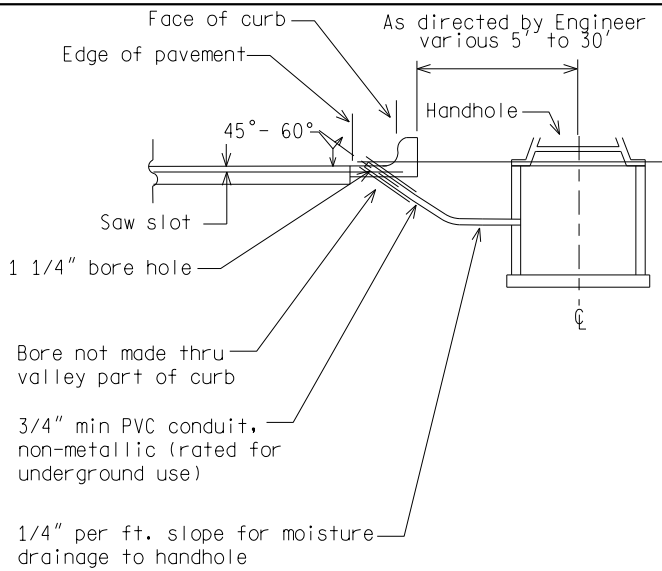

TYPE I
SECTION "C-C"
UNDER CURB INSTALLATION

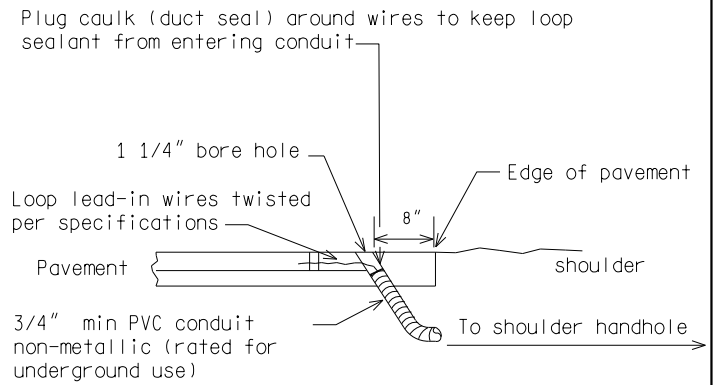

TYPE II
BORE HOLE & LOOP WIRING
SECTION "D-D"
UNDER PAVEMENT INSTALLATION

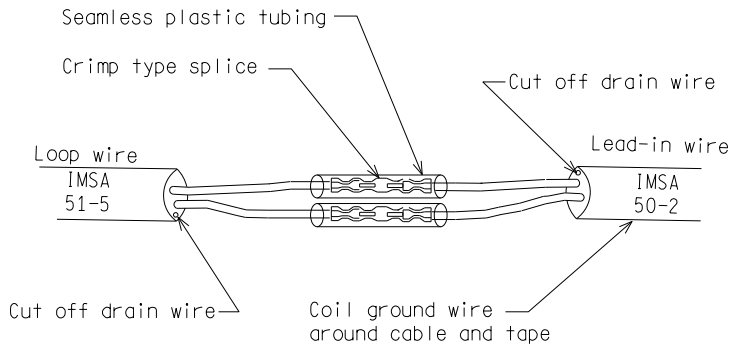

HANDHOLE & PULL-BOX SPLICES
(WATERPROOF)

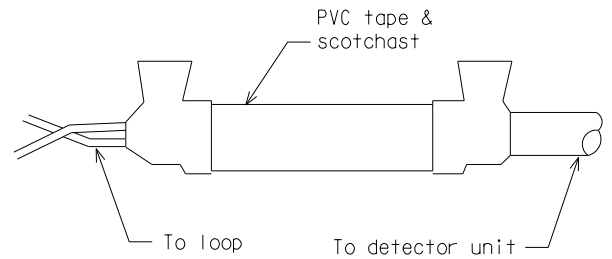

CONTROLLER CABINET CONNECTION

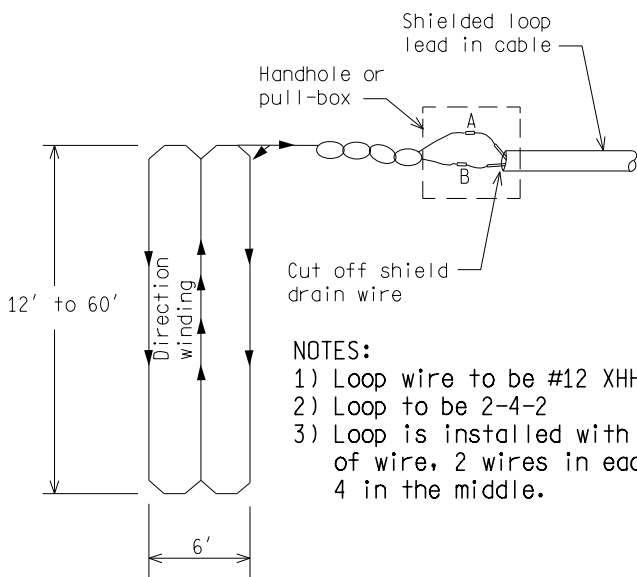

SERIES LOOP CONNECTION

- NOTES:
- 1) Loop wire to be #12 XHHW
 - 2) Loop to be 2-4-2
 - 3) Loop is installed with a double layer of wire, 2 wires in each outside cut, 4 in the middle.

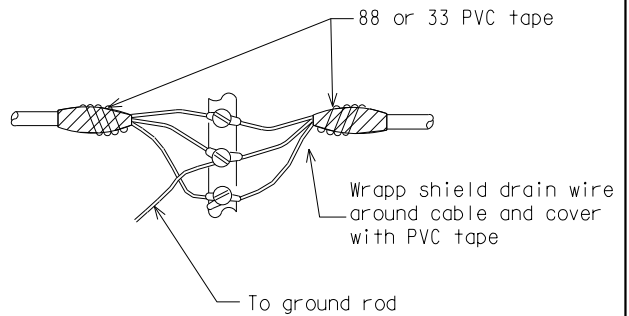

NOT TO SCALE

MICHIGAN DEPARTMENT OF TRANSPORTATION
BUREAU OF HIGHWAYS DELIVERY STANDARD PLAN

(SPECIAL DETAIL)
FHWA APPROVAL DATE

PLAN DATE

WC-170-A

SHEET
3 of 4

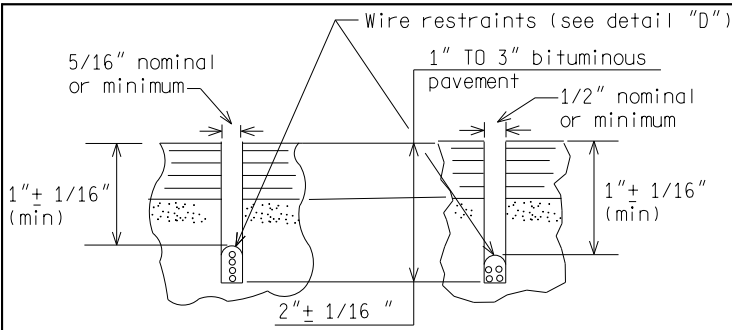

SECTION A-A
LOOP SLOT

SECTION B-B
LEAD-IN SLOT

SLOT CROSS SECTIONS
(BITUMINOUS PAVEMENT OVER CONCRETE)

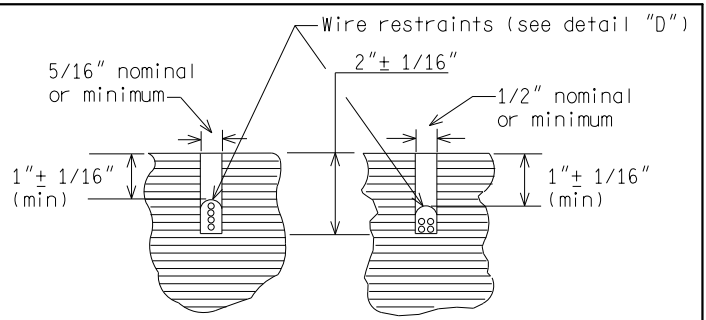

SECTION A-A
LOOP SLOT

SECTION B-B
LEAD-IN SLOT

SLOT CROSS SECTIONS
(BITUMINOUS PAVEMENT)

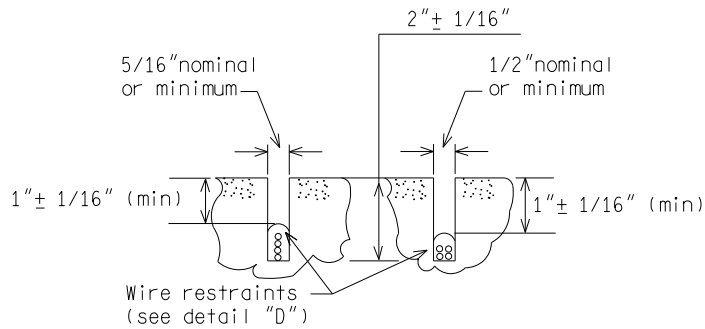

SECTION A-A
LOOP SLOT

SECTION B-B
LEAD-IN SLOT

SLOT CROSS SECTIONS
(CONCRETE PAVEMENT)

NOT TO SCALE

MICHIGAN DEPARTMENT OF TRANSPORTATION
BUREAU OF HIGHWAYS DELIVERY STANDARD PLAN

(SPECIAL DETAIL)
FHWA APPROVAL DATE

PLAN DATE

WC-170-A

SHEET
4 of 4