

REVENUE SERVICE BRAKE LINING TEMPERATURE  
MEASUREMENTS FOR A RETARDER EQUIPPED BUS



**TESTING AND RESEARCH DIVISION  
RESEARCH LABORATORY SECTION**

REVENUE SERVICE BRAKE LINING TEMPERATURE  
MEASUREMENTS FOR A RETARDER EQUIPPED BUS

L. E. DeFrain

Research Laboratory Section  
Testing and Research Division  
Research Project 81 TI-728  
Research Report No. R-1215

Michigan Transportation Commission  
William C. Marshall, Chairman;  
Lawrence C. Patrick, Jr., Vice-Chairman;  
Hannes Meyers, Jr., Carl V. Pellonpaa,  
Weston E. Vivian, Rodger D. Young  
James P. Pitz, Director  
Lansing, March 1983

The information contained in this report was compiled exclusively for the use of the Michigan Department of Transportation. Recommendations contained herein are based upon the research data obtained and the expertise of the researchers, and are not necessarily to be construed as Department policy. No material contained herein is to be reproduced—wholly or in part—without the expressed permission of the Engineer of Testing and Research.

## Background

Brake linings on revenue coaches have a limited life due to high temperatures. Repeated brake applications on busy urban routes do not allow the linings to cool. Therefore, the lining temperature continues to rise until it stabilizes at some elevated temperature. If the braking effort could be supplemented by some other device, the linings would not overheat and their useful life would be prolonged. In response to a request by the Bureau of Urban and Public Transportation, this investigation was undertaken to evaluate the effectiveness of one such device.

## Research Procedure

A "Telma" electric brake retarder was installed on a revenue bus in the City of Detroit. This device supplies the majority of braking force until the bus speed is reduced to approximately 5 miles per hour. The remainder of the brake effort is supplied by the linings.

The Woodward Ave bus line between Jefferson Ave and the State Fair Grounds was used for evaluating the electric brake retarder. This route is characterized by frequent stopping; between periods of high accelerations and decelerations.

The effectiveness of the retarder was determined by continuously measuring brake lining temperature while the bus was in operation. Data were collected with the retarder in operation and with braking provided by the brake linings only.

## Instrumentation Procedure

Temperature measurements of the brake linings were obtained from resistive temperature transducers (600 C RTD). Temperature measurements of the floor above the retarder and air bags were obtained from copper-constantan thermocouples.

Vehicle speed and hydraulic brake pressure were also measured using a wheel tachometer and pressure transducer. Transducer outputs were conditioned, amplified, and scaled for recording on magnetic tape. Data were recorded on a 14-channel FM recorder (Honeywell 5600C).

In the laboratory, the data were digitized and plotted using a hybrid computer system and the Department's B6700 computer.

The brake lining temperature transducers were installed as shown in Figure 1. Placement of these devices was in accordance with SAE Procedure J 786a with the exception of using the RTD transducers in lieu of thermocouples. The instrumentation procedure allowed the temperature at the drum/lining interface to be measured. The RTD transducers were installed on both linings of all four wheels.

#### Equipment Storage

The signal conditioning equipment was located in a compartment near the front of the bus. The equipment was supplied with 24-v d.c. power source for operation. The tape recorder was placed on a seat in the bus and operated by a technician. The 12-v d.c. power for the recorder was obtained from the bus battery.

#### Test Procedure

RTD devices were installed in the linings at the Research Laboratory in Lansing. Transducer leads were extended and secured for easy attachment to cabling. The instrumented linings were subsequently installed on a bus (vehicle No. 1807) by Detroit DOT personnel. The bus was then driven several days to wear in the linings. Subsequently, transducer cabling was installed and equipment was placed on the seat behind the driver. After system check-out the bus was placed into revenue service.

Data were collected almost continuously on February 9, 1982, between the hours of 2:00 and 8:00 p. m. During this time, four trips were made on Woodward Ave between the Fair Grounds and Jefferson Ave. The first trip was 18 miles long (round trip) and required approximately two hours to complete. The remaining three trips were 9 miles long (one way trips). The test runs encompassed the evening rush hour period. There were many times when the coach was filled to capacity with patrons standing the full length of the aisle. The outside temperature was -3 C (27 F) at 2:00 p.m. and dropped gradually to -10 C (15 F) at 8:00 p.m. The inside bus temperature at a level 6 ft from the floor was approximately 21 C (70 F) during the testing. During the high volume period this inside temperature increased to 27 C (80 F).

The retarder was placed in operation on alternate trips. Therefore, two trips were made with the retarder operating and two trips without it functioning.

## Test Results

A typical sample of the recorded test temperatures showing the variation in brake lining temperature for each of the four trips is shown in Figures 2 through 6. The large spike in the temperature data was caused by radio transmitter interference which occurred at several places along the route.

Table 1 is a summary of the average brake lining temperatures measured for each of the four trips. Runs No. 1 and No. 4 were with the retarder in operation and Runs No. 2 and No. 3 were conducted using standard brakes only.

TABLE 1  
AVERAGE BRAKE LINING TEMPERATURES  
(in degrees Celsius)

Run No.	Right Front Top	Right Front Bottom	Right Rear Top	Right Rear Bottom	Left Front Bottom	Outside Temperature, degrees C
1	75	65	104	110	65	-3
2	130	130	155	170	130	-8
3	115	115	155	170	115	-9
4	55	55	70	55	55	-10

Peak brake lining temperatures obtained from the data were 110 C during Run No. 1 (retarder in operation), and 175 C during Run No. 2 when the retarder was not in operation. When the retarder was taken out of operation, during Run No. 2, the rise in lining temperature is apparent in Figure 4. The lining temperatures seem relatively constant during Run No. 3. The decrease in lining temperatures during Run No. 4 is also apparent in Figure 6.

Air bag temperatures and the floor of the coach directly above the retarder were also measured at random intervals during the runs. The results of Runs No. 1 and No. 2 are given in Table 2.

The falling temperatures during Run No. 2 shown in Table 2 are the result of not using the retarder.

TABLE 2  
AIR BAG AND FLOOR TEMPERATURE MEASUREMENTS  
(in degrees Celsius)

Run No.	Air Bag Temperature	Floor Temperature
1 (with retarder)	21	20
	36	39
	26	45
	39	47
2 (without retarder)	13	39
	11	24
	6	16
	-1	6
	-2	3

Conclusions

Average brake lining temperatures were reduced by approximately 60 C when the retarder was in operation. As a result, brake lining life should be significantly increased. Only the coach floor above the retarder and air bag area experienced elevated temperatures as a result of its operation.

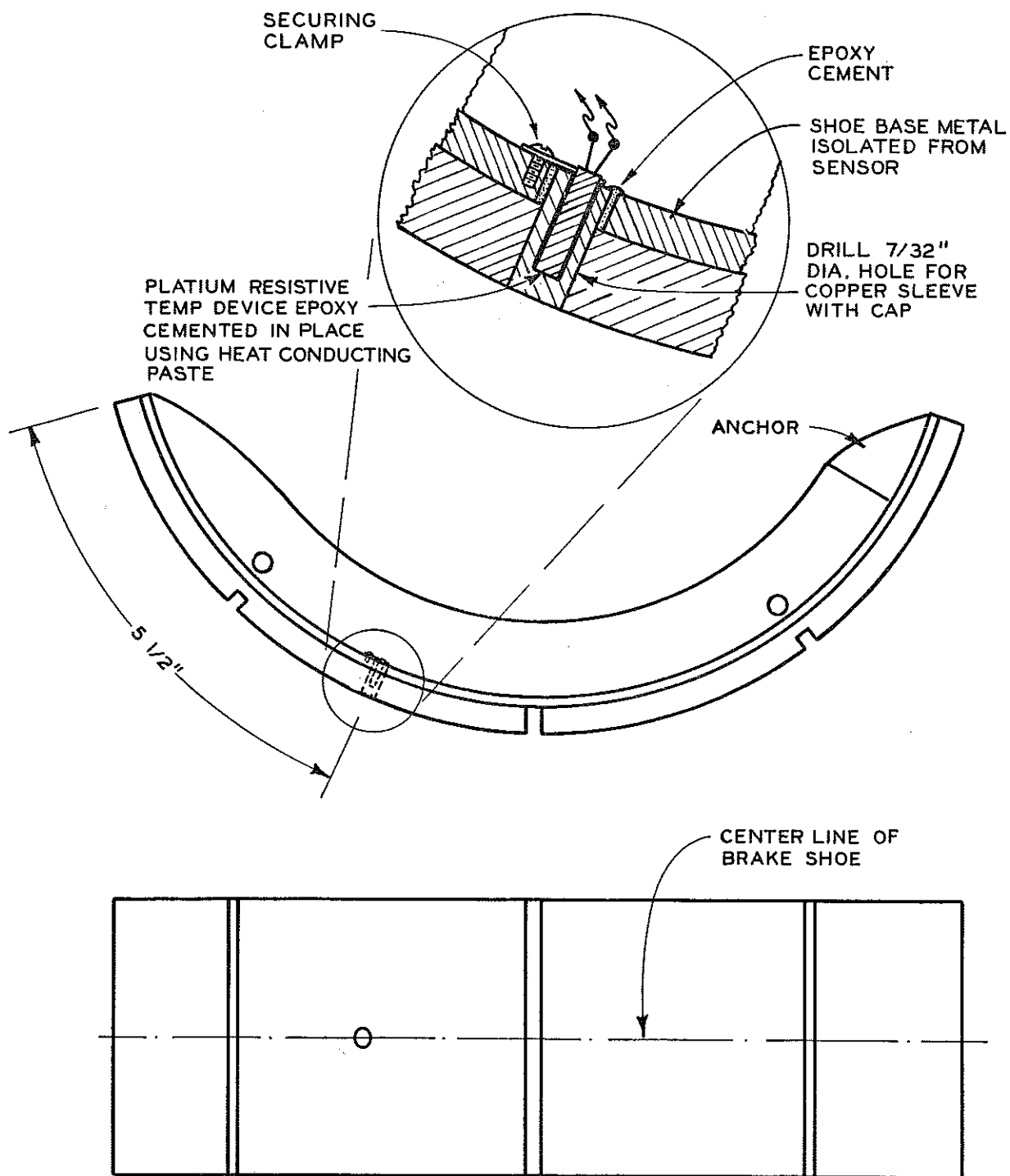

Figure 1. Instrumentation of brake shoe linings using RTD transducer.



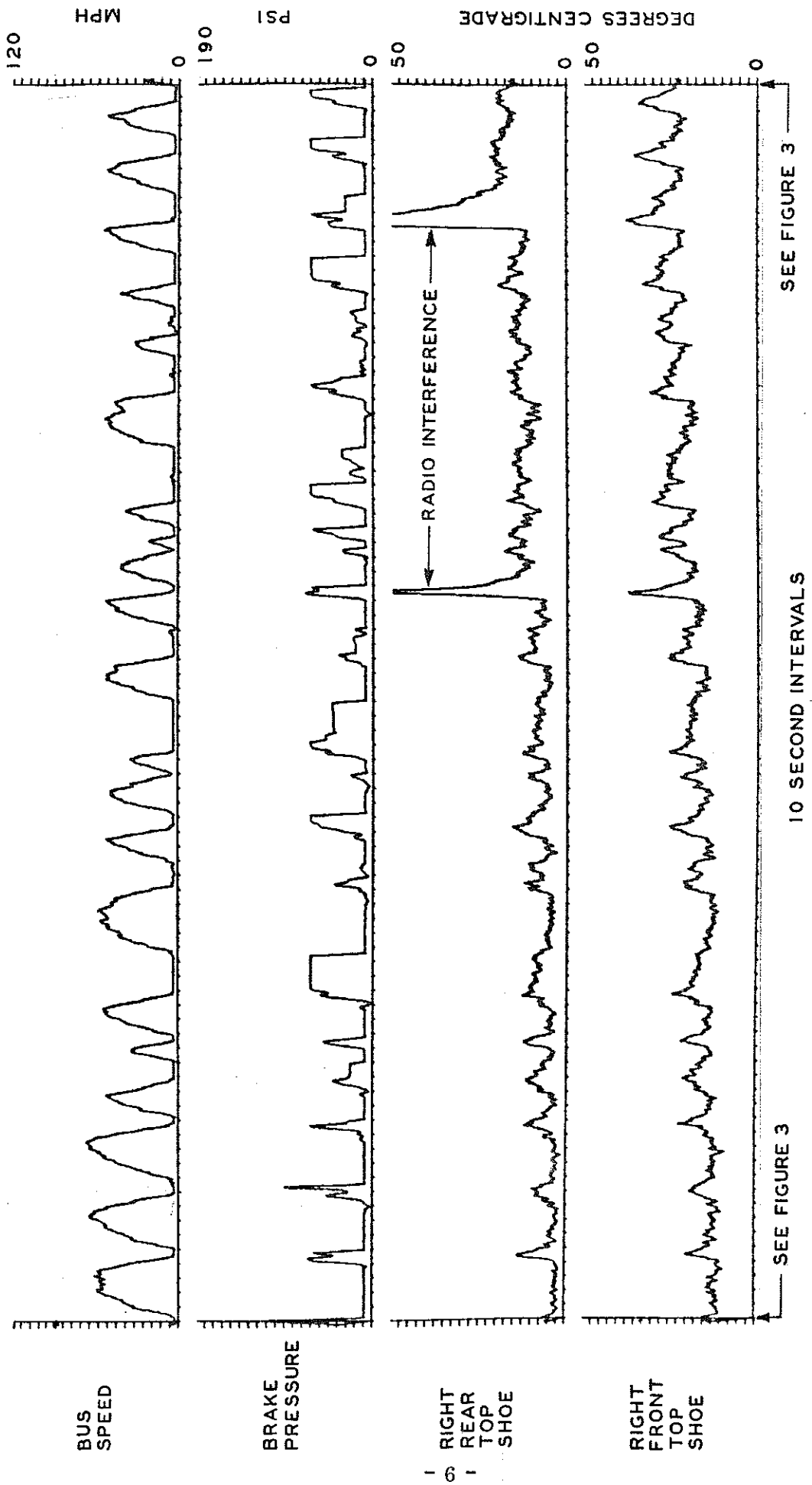

Figure 2. Brake lining temperature measurements (Run No. 1) with retarder in operation.

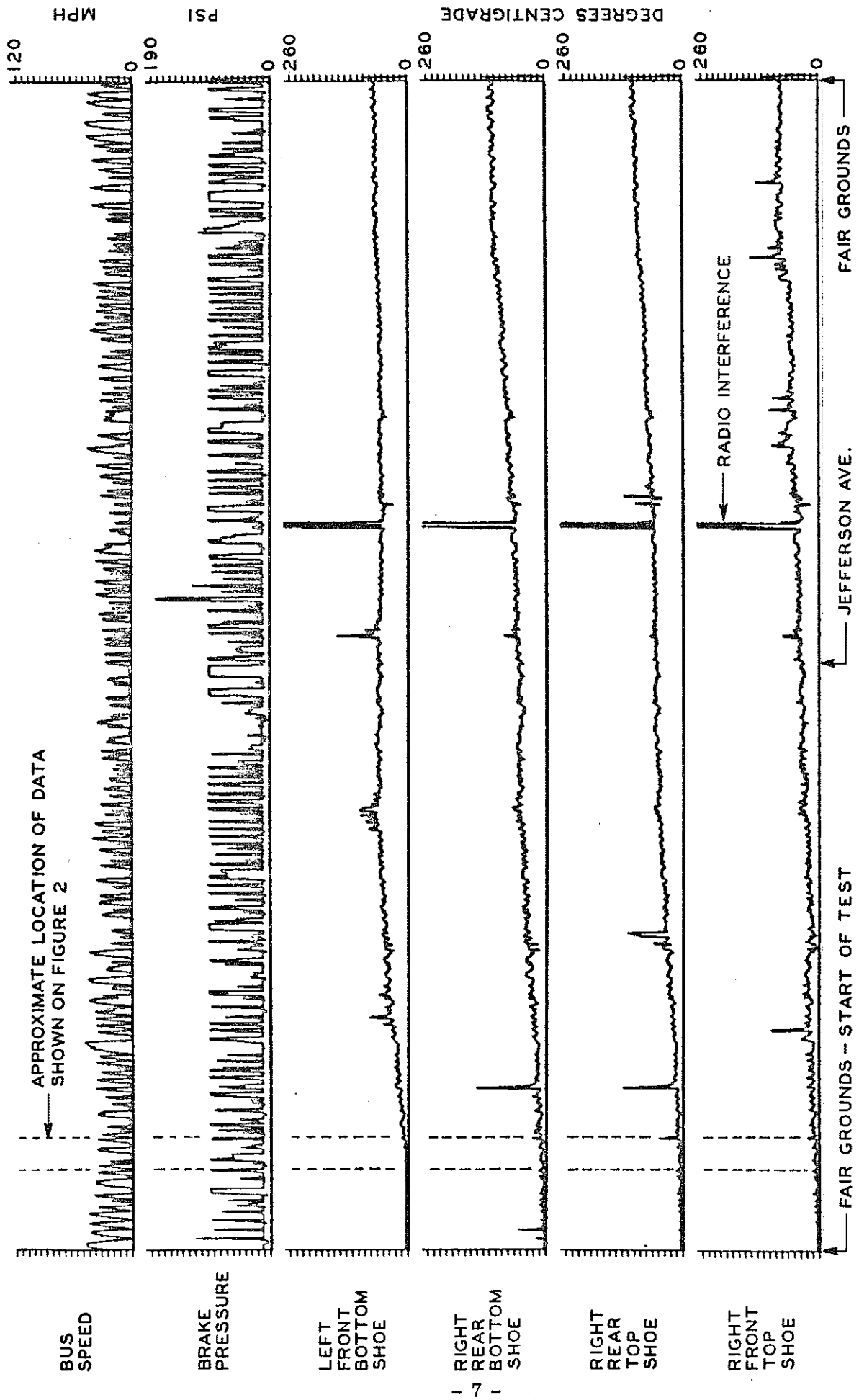

Figure 3. Brake lining temperature measurements (Run No. 1) with retarder in operation.

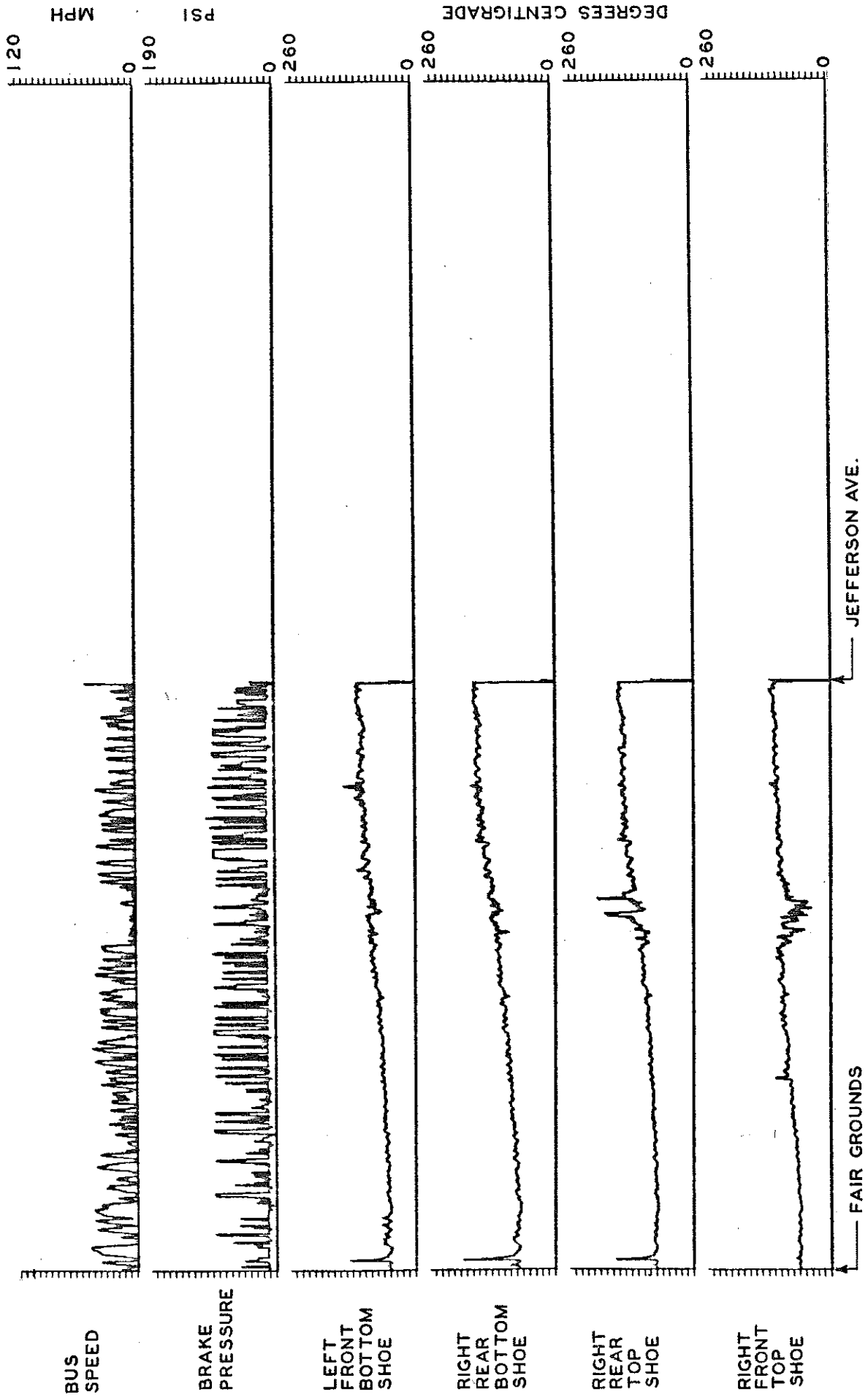

Figure 4. Brake lining temperature measurements (Run No. 2) with retarder not in operation.



Figure 5. Brake lining temperature measurements (Run No. 3) with retarder not in operation.

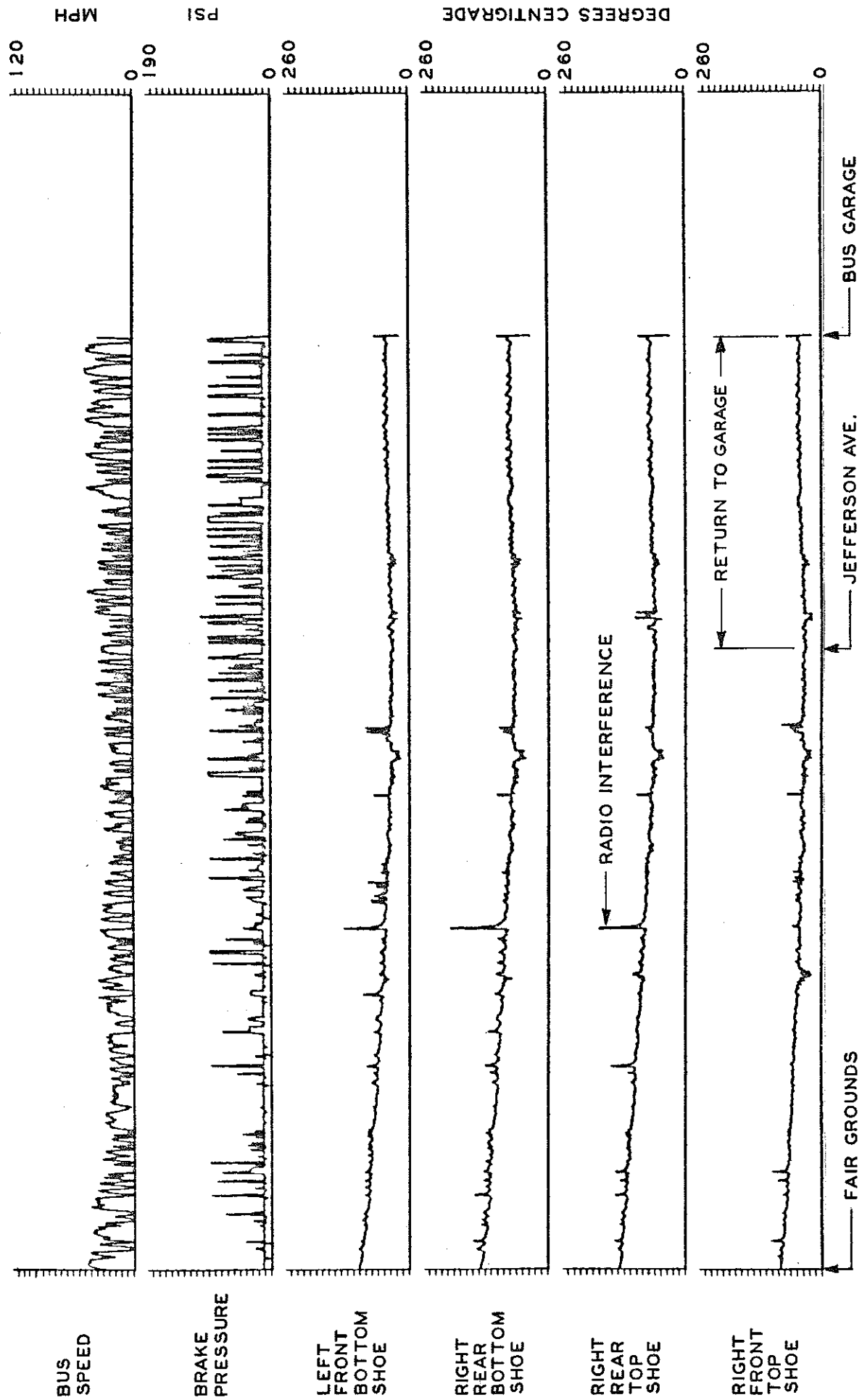

Figure 6. Brake lining temperature measurements (Run No. 4) with retarder in operation.