

ISOMETRIC VIEW

TRUSS DATA					
TRUSS SPAN (FT)	NUMBER OF PANELS	END PANEL LENGTH (FT)	TRUSS DEPTH (CHORD-TO-CHORD) (FT)	BASE PLATE DIAMETER (IN)	*CAMBER AT MIDPOINT (IN)
50	5	10.0	6.0	38	5/8
55	6	7.5			3/4
65	6	10.0			7/8
70	7	7.5			1
75	7	10.0			1 1/8
80	8	7.5			1 1/8
85	8	10.0			1 1/4
90	9	7.5			1 3/8
95	9	10.0			1 1/2
100	10	7.5			1 3/4
110	10	10.0			1 7/8
105	11	7.5	8	42	2
110	11	10.0			2
115	12	7.5			2 1/8
120	12	10.0			2 1/4
125	13	7.5			2 1/2
130	13	10.0			2 3/4
135	14	7.5			2 3/4
140	14	10.0			3 1/8

*SEE CAMBER DIAGRAM SHEET 3

APPROVED BY: _____
DIRECTOR, BUREAU OF FIELD SERVICES

APPROVED BY: _____
DIRECTOR, BUREAU OF DEVELOPMENT



DEPARTMENT DIRECTOR
BRADLEY C. WIEFERICH, PE

STANDARD PLAN FOR
STEEL TRUSS TYPE E
(50FT - 140FT)

(SPECIAL DETAIL)
FHWA APPROVAL

08/08/23
PLAN DATE

SIGN 360-C

SHEET
1 OF 10

NOTES:

1. THE DESIGN OF THIS STRUCTURE IS BASED ON THE AASHTO LRFD SPECIFICATIONS FOR STRUCTURAL SUPPORTS FOR HIGHWAY SIGNS, LUMINAIRES AND TRAFFIC SIGNALS, 1ST EDITION, WITH INTERIM REVISIONS THROUGH 2022.
2. WELDING MUST BE IN ACCORDANCE WITH AWS D1.1 AS SPECIFIED IN 20SP-707A, STRUCTURAL STEEL AND ALUMINUM CONSTRUCTION.
3. MAXIMUM SIGN AREA IS 1200 SQUARE FEET. SIGNS MUST NOT PROJECT PAST THE ENDS OF THE TRUSS. MAXIMUM 6 FOOT SIGN PROJECTION ABOVE THE TOP CHORD.
4. FOR TRUSS LENGTHS 50 FEET TO 105 FEET, MINIMUM SIGN HEIGHT WITH ALUMINUM BEAM IS 7 FEET. FOR TRUSS LENGTHS 100 FEET TO 140 FEET, MINIMUM SIGN HEIGHT WITH ALUMINUM BEAM IS 9 FEET.
5. TYPE I SIGNS MUST NOT BE USED ON THE SAME TRUSS AS VARIABLE MESSAGE SIGNS.
6. GALVANIZING OF BOLT ASSEMBLIES SHALL BE IN ACCORDANCE WITH SUBSECTIONS 919.07.I AND 906.07 OF THE MDOT STANDARD OF SPECIFICATIONS FOR CONSTRUCTION.
7. PROVIDE 15/16" DIAMETER HIGH STRENGTH (HS) BOLTS FOR ALL CONNECTIONS UNLESS OTHERWISE STATED. PROVIDE HIGH STRENGTH BOLTS, NUTS, AND WASHERS IN ACCORDANCE WITH SUBSECTION 906.07 OF THE MDOT STANDARD SPECIFICATIONS FOR CONSTRUCTION. PROVIDE LOCK WASHERS THAT MEET ASME B18.21.1.
8. TIGHTEN ALL HIGH STRENGTH (HS) BOLTS BY THE TURN OF NUT METHOD PER SUBSECTION 707.03.E OF THE MDOT STANDARD SPECIFICATIONS FOR CONSTRUCTION.
9. DO NOT LIFT THE TRUSS BY THE WEB MEMBERS.
10. FIELD SPLICES MAY BE PLACED ALONG THE TRUSS CHORD TO FACILITATE FABRICATION. PLACE FIELD SPLICE 1'-6" MINIMUM TO THE GUSSET PLATE EDGE. ANY DEVIATION FROM THE DETAILS SHOWN ON THIS TYPICAL WILL REQUIRE APPROVAL BY THE ENGINEER IN WRITING BEFORE FABRICATION.
11. ALL WELDS MUST BE INSPECTED IN ACCORDANCE WITH SUBSECTION 707.03.D.12 OF THE STANDARD SPECIFICATIONS FOR CONSTRUCTION, EXCEPT MINIMUM MT INSPECTION FREQUENCY IS INCREASED TO 25 PERCENT.
12. SEE CURRENT MDOT SIGN SUPPORT TYPICAL PLAN SIGN-340-SERIES FOR SIGN FOUNDATION.
13. SEE CURRENT MDOT SIGN SUPPORT TYPICAL PLAN SIGN-700-SERIES FOR SIGN CONNECTION.
14. COLUMN SECTIONS MUST BE ASTM A53, GRADE B OR API-5L-X42. SECTIONS FOR 50 FEET TO 105 FEET TRUSSES MUST BE 24" BY 0.969". SECTIONS FOR 110 FEET TO 140 FEET TRUSSES MUST BE 24" BY 1.219". CHORD SECTIONS MUST BE ASTM A500 GRADE B 6 5/8" x 0.432 OR ASTM A519-4140 ANNEALED 6" x 0.375.
15. WEB ANGLES MUST BE ASTM A709, GRADE 36 OR ASTM A36 L5" X 5" X 7/16" OR L5" X 5" X 1/2". STEEL PLATES MUST BE ASTM A709, GRADE 36 OR 50, ASTM A36, OR ASTM A572 GRADE 50.
16. THE ESTIMATED WEIGHT OF THE TRUSS IS 195 LBS/FT.
17. DURING THE ERECTION PROCESS THE MINIMUM NUMBER OF BOLTS REQUIRE TO BE INSTALL PRIOR TO LETTING TRAFFIC RESUME UNDER THE ERECTED TRUSS MUST BE: 2 BOLTS MINIMUM PER CHORD-COLUMN CONNECTION PLATE FOR SPAN LENGTHS BETWEEN 50' AND 105', AND 4 BOLTS MINIMUM PER CHORD-COLUMN CONNECTION PLATE FOR SPAN LENGTHS BETWEEN 110' AND 140'. NO SIGNS SHALL BE ERECTED UNTIL ALL BOLTS ARE INSTALLED.
18. BASE PLATE (B) WARPAGE MUST NOT EXCEED 1/16 INCH PER FOOT.
19. CJP WELDS ON OPTIONAL COLUMN AND ARM SPLICES SHALL BE GROUND SMOOTH. ANY GRINDING OF WELDS IS TO BE DONE PRIOR TO GALVANIZATION. WELDING SHALL BE IN ACCORDANCE WITH SECTION 707 OF THE STANDARD SPECIFICATIONS FOR CONSTRUCTION.
20. SELECT SEALANT FOR PERIMETER OF BACKING BAR PLATE FROM THE QUALIFIED PRODUCTS LIST. PROVIDE SEALANT IN CAULKING TUBES.
21. CHARPY V-NOTCH TESTING IS REQUIRED FOR THE COLUMN UPRIGHT IN ACCORDANCE WITH THE AASHTO LRFD SPECIFICATIONS FOR STRUCTURAL SUPPORTS FOR HIGHWAY SIGNS, LUMINAIRES, AND TRAFFIC SIGNALS, 1ST EDITION, WITH INTERIM REVISIONS THROUGH 2022.



DEPARTMENT DIRECTOR
BRADLEY C. WIEFERICH, PE

STANDARD PLAN FOR
STEEL TRUSS TYPE E
(50FT - 140FT)

(SPECIAL DETAIL)
FHWA APPROVAL

08/08/23
PLAN DATE

SIGN 360-C

SHEET
2 OF 10

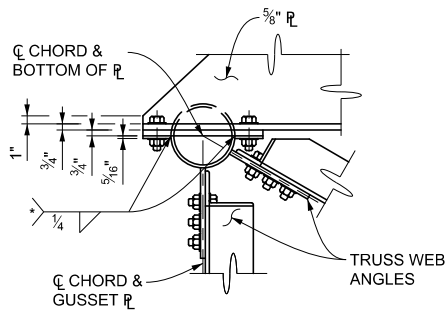

DETAIL A

* TOP AND BOTTOM CHORD

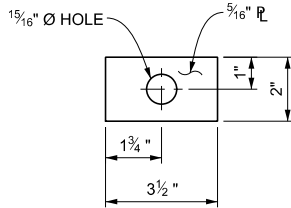
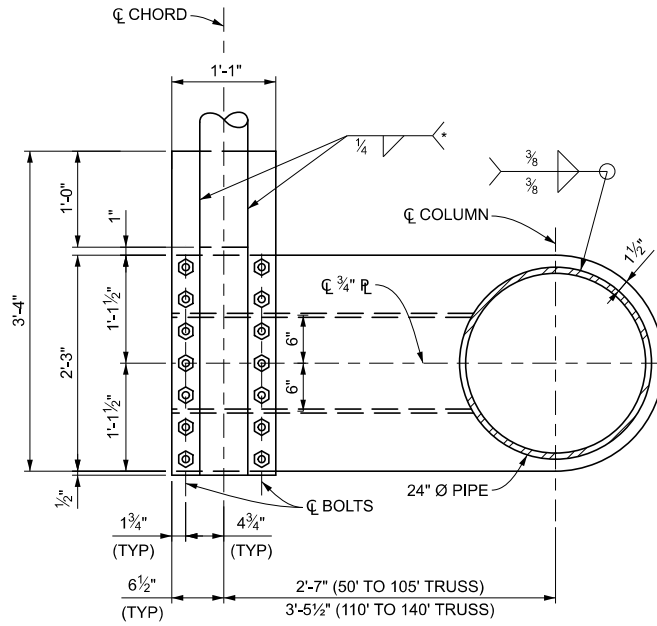
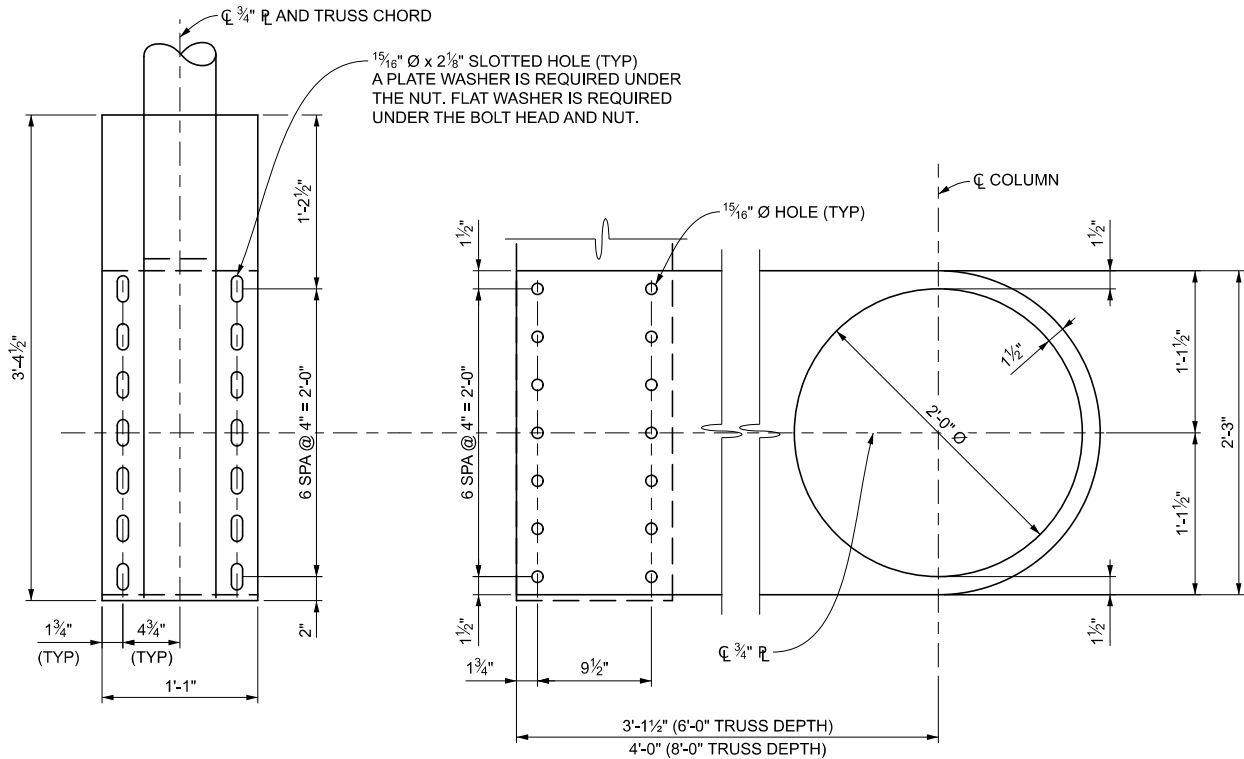

PLATE WASHER DETAIL



SECTION B-B

WEB MEMBERS AND CONNECTION PLATES OMITTED FOR CLARITY.
TOP CHORD SIMILAR
* TOP AND BOTTOM CHORD



CHORD-COLUMN CONNECTION PLATE DETAILS

<p>DEPARTMENT DIRECTOR BRADLEY C. WIEFERICH, PE</p>	<p>STANDARD PLAN FOR STEEL TRUSS TYPE E (50FT - 140FT)</p>		<p>SHEET 4 OF 10</p>
	<p>(SPECIAL DETAIL) FHWA APPROVAL</p>	<p>08/08/23 PLAN DATE</p>	

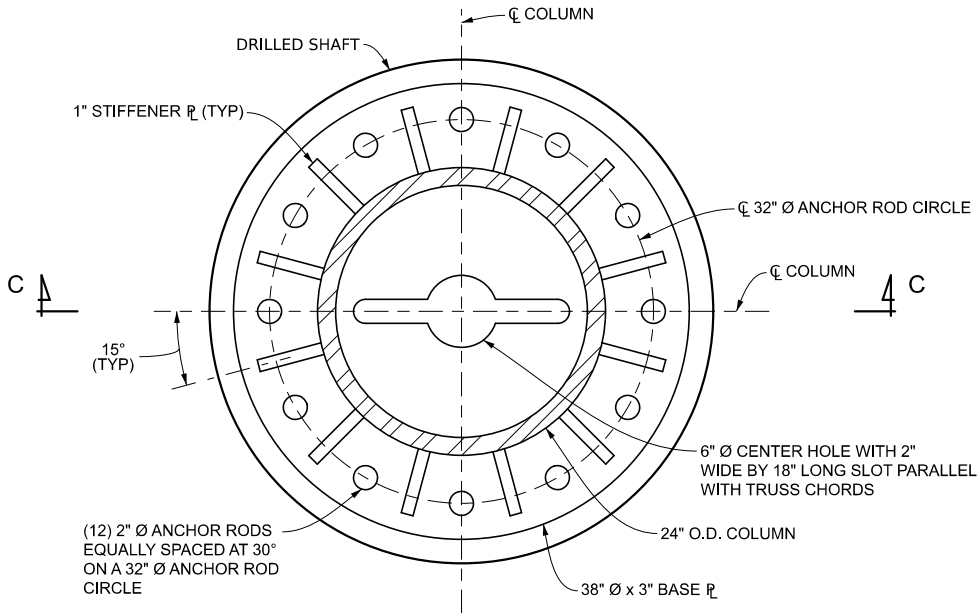

PLAN VIEW 38" BASE PLATE DETAIL

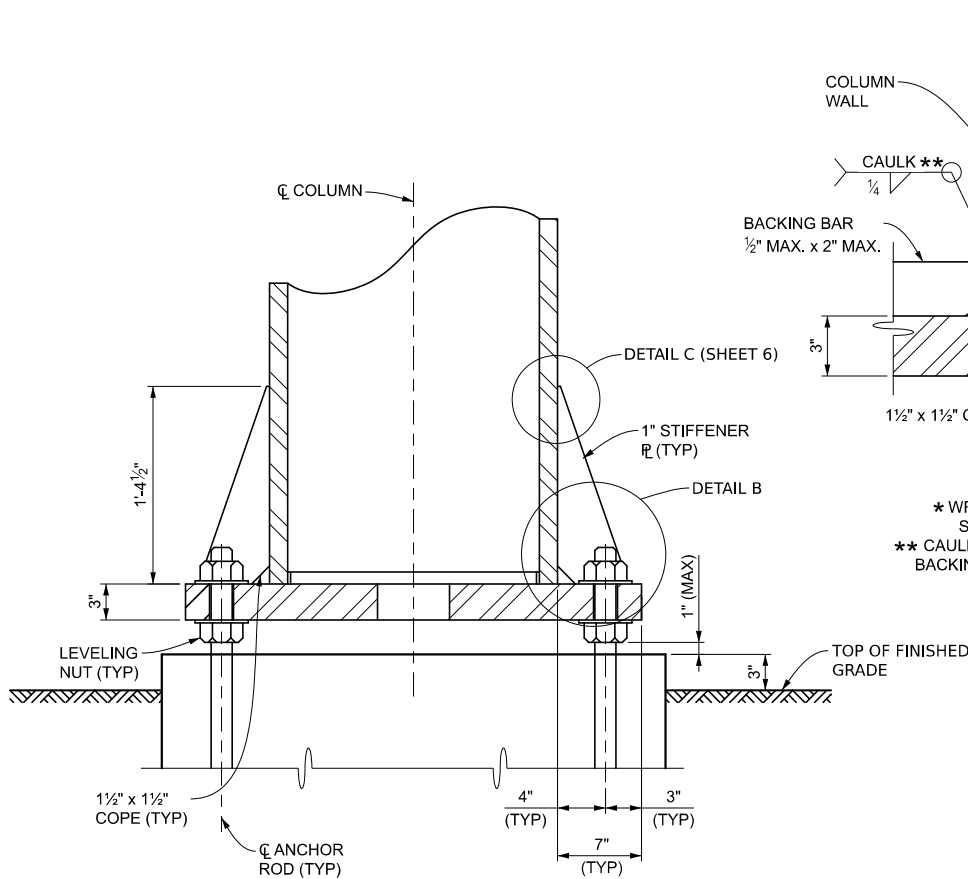

SECTION C-C

ELEVATION VIEW FOR 50' TO 105' TRUSS

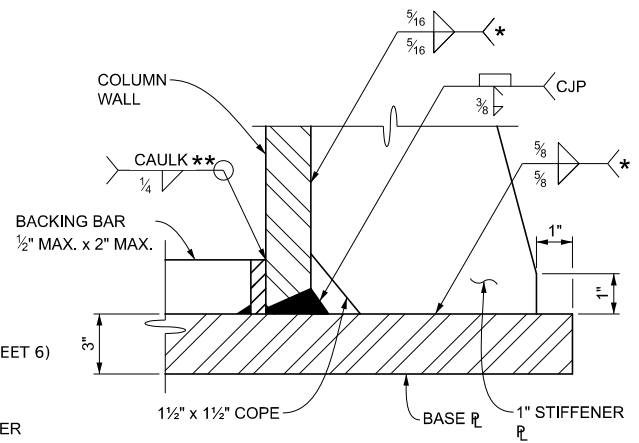

DETAIL B

- * WRAP WELD AROUND OUTSIDE EDGE STOP 1/4" SHORT OF CORNER CLIP
- ** CAULK TOP OF UNWELDED JOINT BETWEEN BACKING BAR AND COLUMN WALL AFTER HDG

MDOT
Michigan Department of Transportation

DEPARTMENT DIRECTOR
BRADLEY C. WIEFERICH, PE

STANDARD PLAN FOR STEEL TRUSS TYPE E (50FT - 140FT)			
(SPECIAL DETAIL)	08/08/23	SIGN 360-C	SHEET 5 OF 10
FHWA APPROVAL	PLAN DATE		

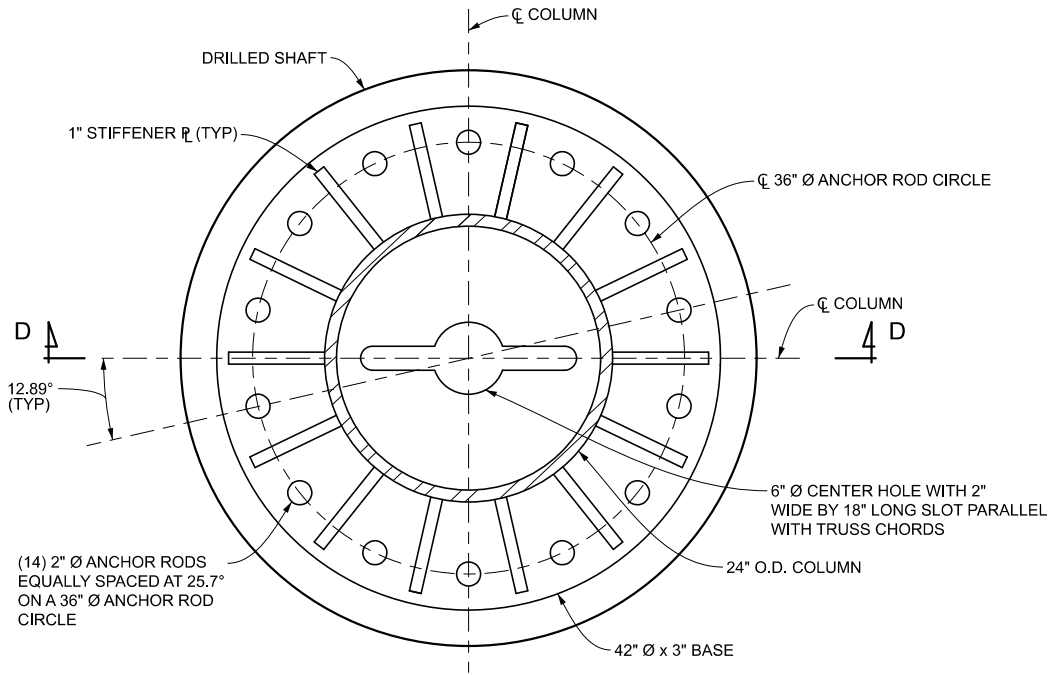

PLAN VIEW 42" BASE PLATE DETAIL

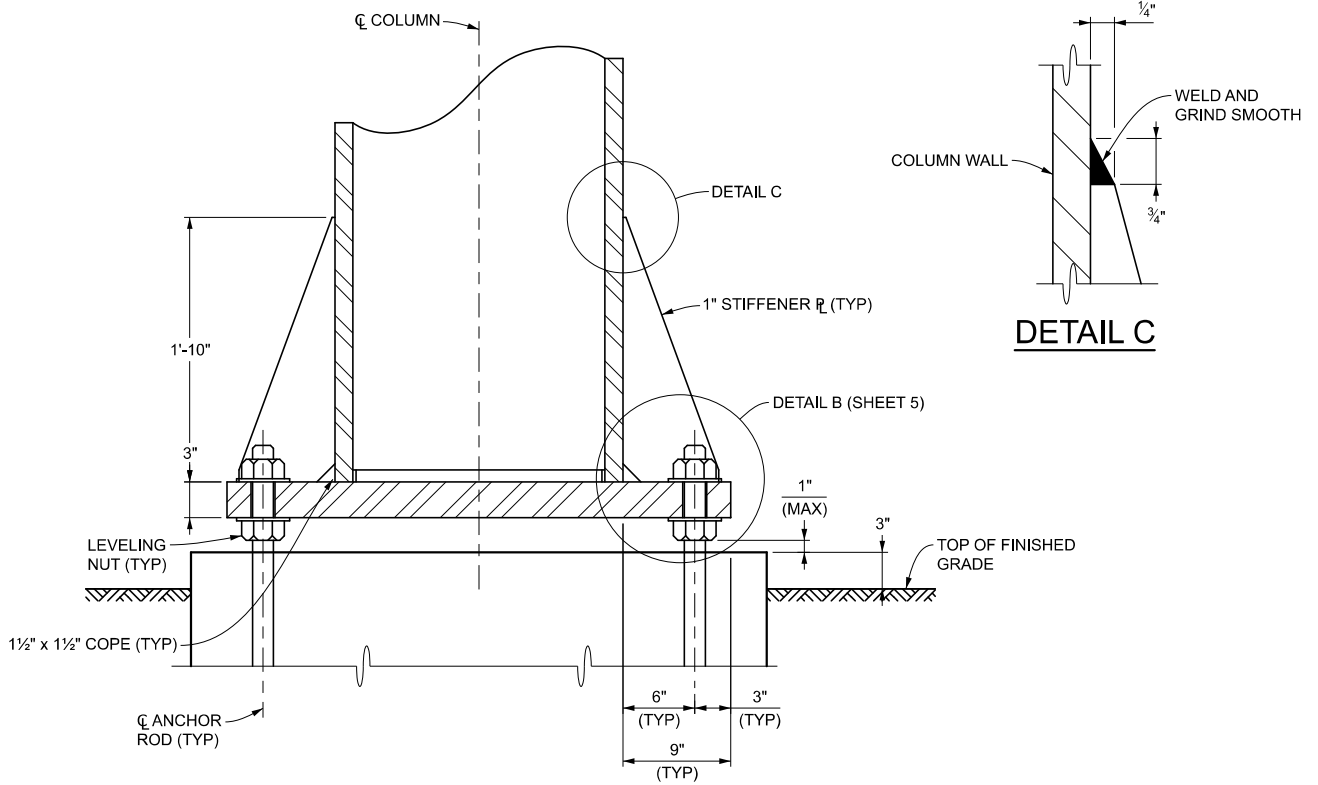

SECTION D-D

ELEVATION VIEW FOR 110' TO 140' TRUSS



DEPARTMENT DIRECTOR
BRADLEY C. WIEFERICH, PE

STANDARD PLAN FOR
STEEL TRUSS TYPE E
(50FT - 140FT)

(SPECIAL DETAIL)
FHWA APPROVAL

08/08/23
PLAN DATE

SIGN 360-C

SHEET
6 OF 10

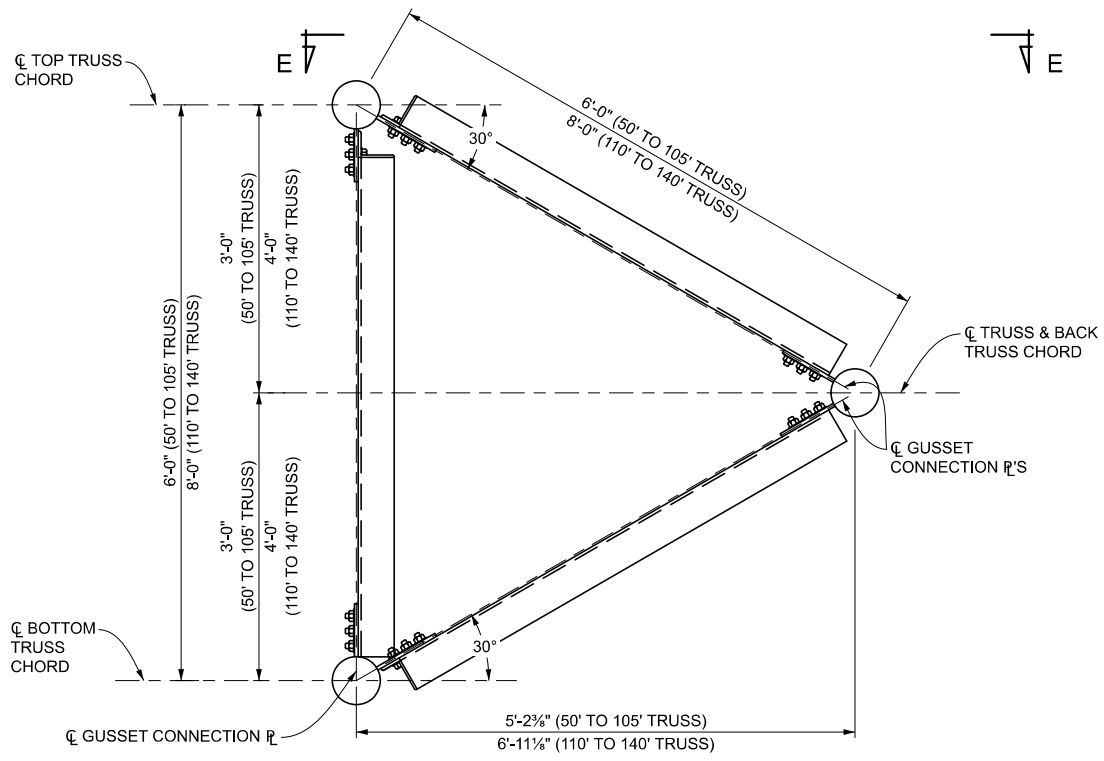

TYPICAL SECTION OF TRUSS

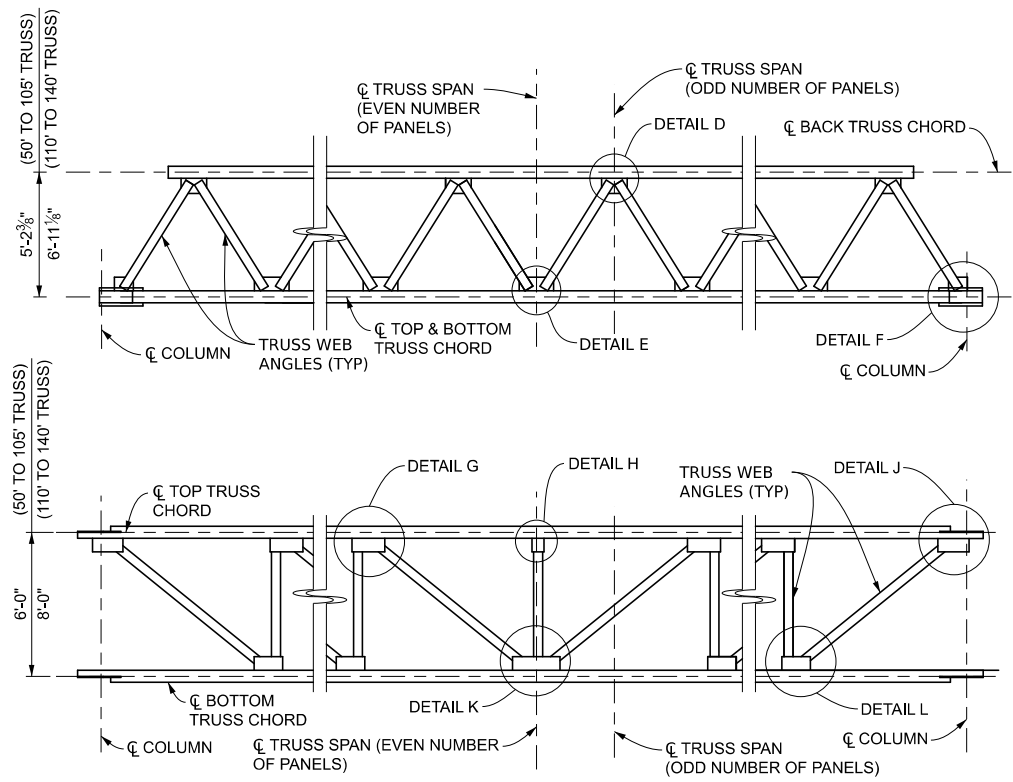

BACK TRUSS CHORD AND ATTACHED ANGLES NOT SHOWN FOR CLARITY
(SEE SHEET 8 FOR DETAILS)

 DEPARTMENT DIRECTOR BRADLEY C. WIEFERICH, PE	STANDARD PLAN FOR STEEL TRUSS TYPE E (50FT - 140FT)		SIGN 360-C	SHEET 7 OF 10
	(SPECIAL DETAIL) FHWA APPROVAL	08/08/23 PLAN DATE		

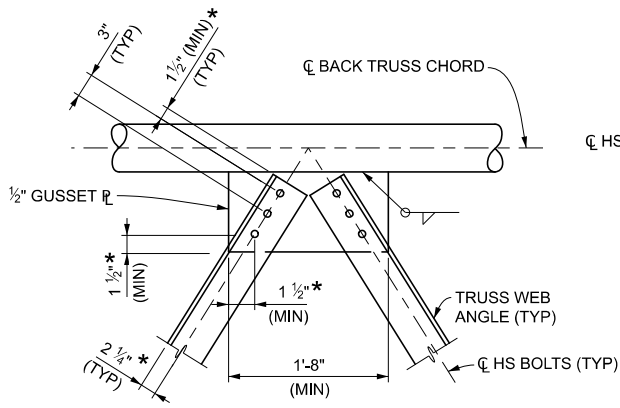

DETAIL D

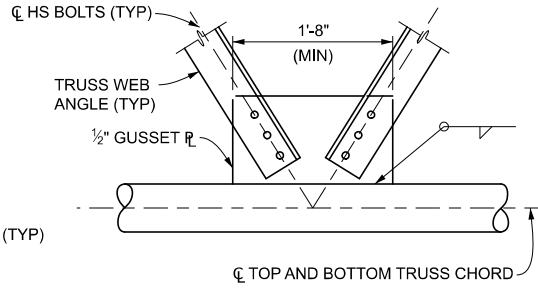

DETAIL E

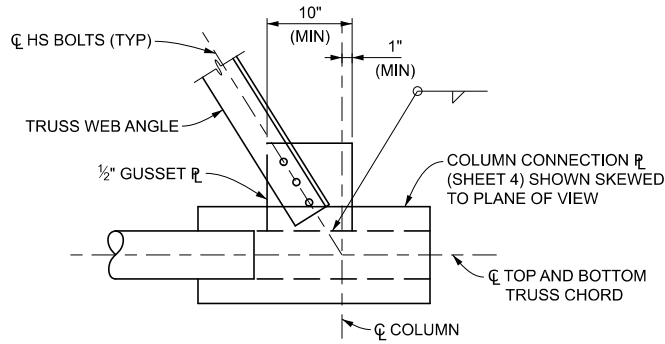

DETAIL F

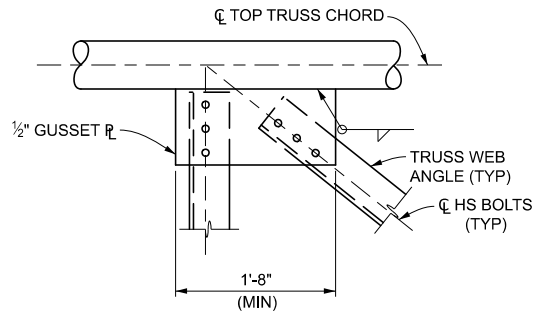

DETAIL G

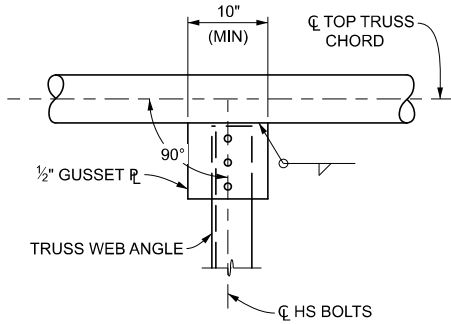

DETAIL H

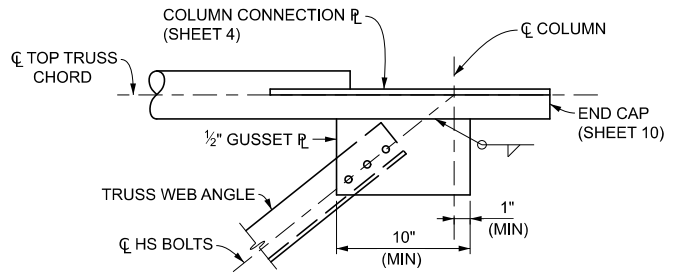

DETAIL J

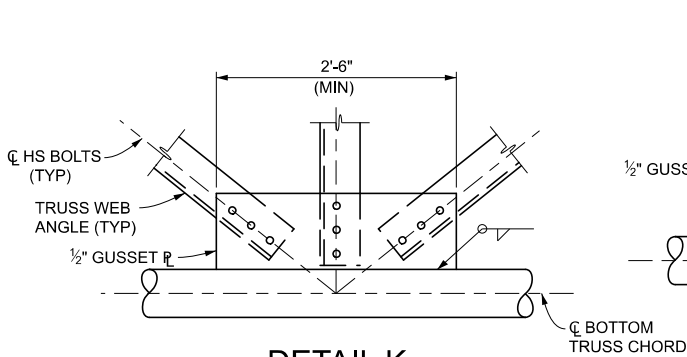

DETAIL K

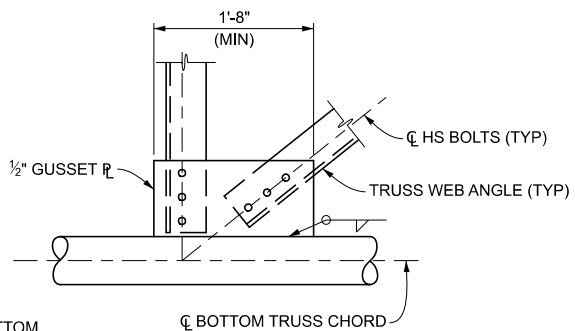

DETAIL L



DEPARTMENT DIRECTOR
BRADLEY C. WIEFERICH, PE

STANDARD PLAN FOR
STEEL TRUSS TYPE E
(50FT - 140FT)

(SPECIAL DETAIL)
FHWA APPROVAL

08/08/23
PLAN DATE

SIGN 360-C

SHEET
8 OF 10

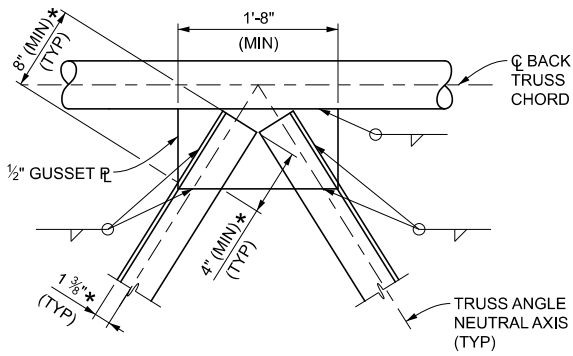

ALTERNATE DETAIL D

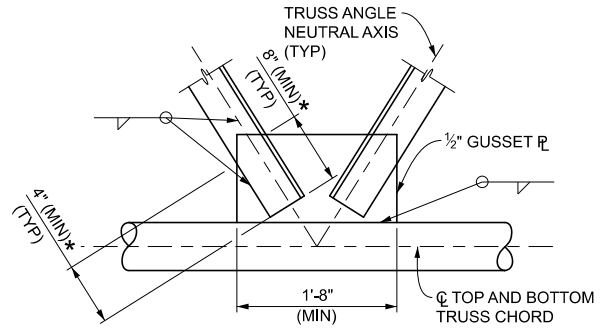

ALTERNATE DETAIL E

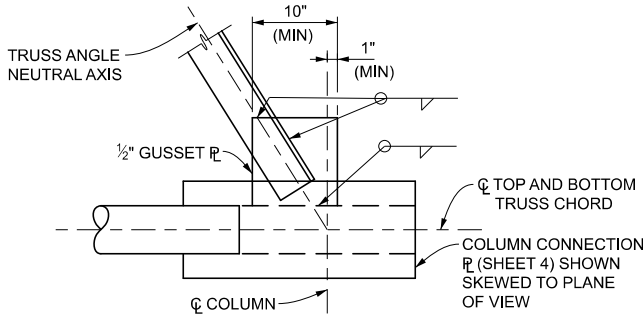

ALTERNATE DETAIL F

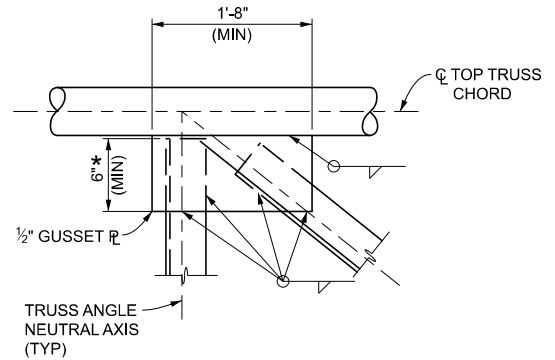

ALTERNATE DETAIL G

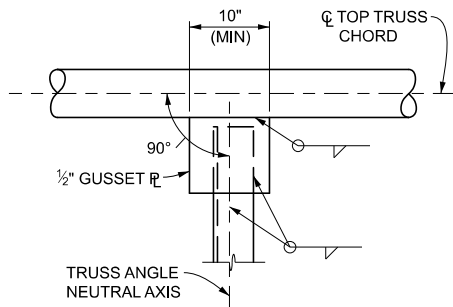

ALTERNATE DETAIL H

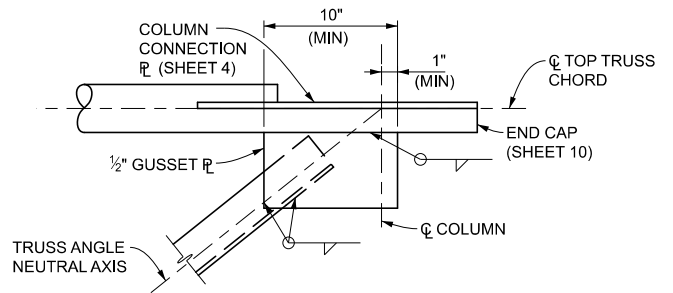

ALTERNATE DETAIL J

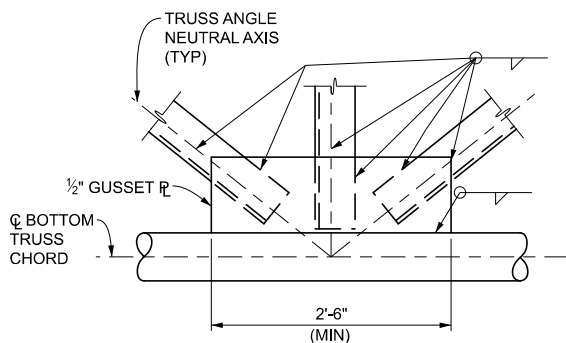

ALTERNATE DETAIL K

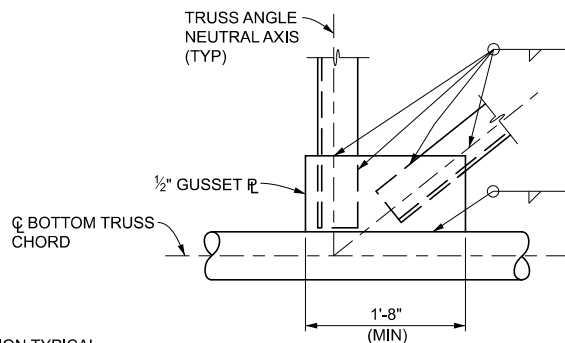

ALTERNATE DETAIL L

* DIMENSION TYPICAL FOR ALL CONNECTION DETAILS.



DEPARTMENT DIRECTOR
BRADLEY C. WIEFERICH, PE

STANDARD PLAN FOR
STEEL TRUSS TYPE E
(50FT - 140FT)

(SPECIAL DETAIL)
FHWA APPROVAL

08/08/23
PLAN DATE

SIGN 360-C

SHEET
9 OF 10

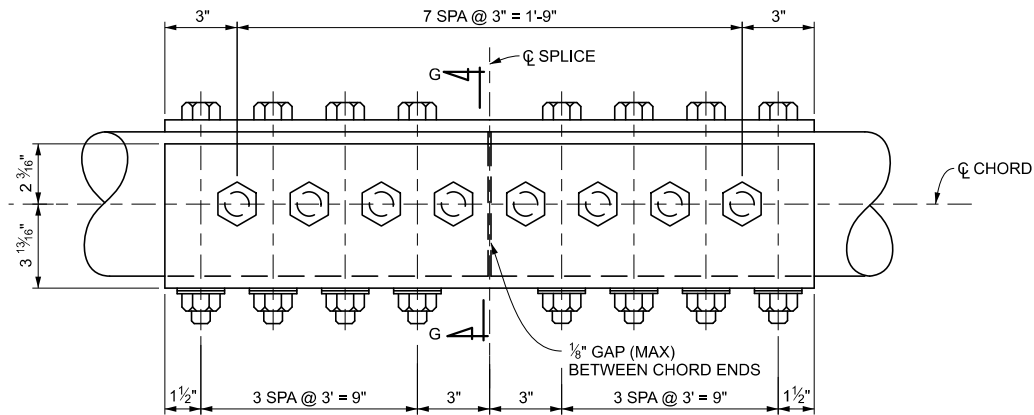

ELEVATION

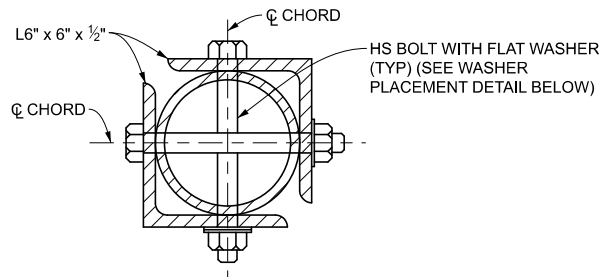

SECTION G-G

CHORD SPLICE CONNECTION DETAILS

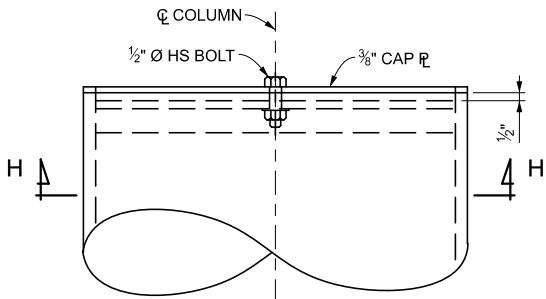

COLUMN CAP DETAIL

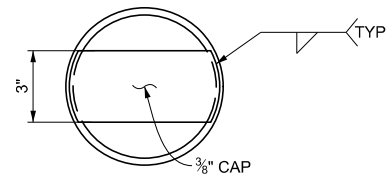

END CAP DETAIL

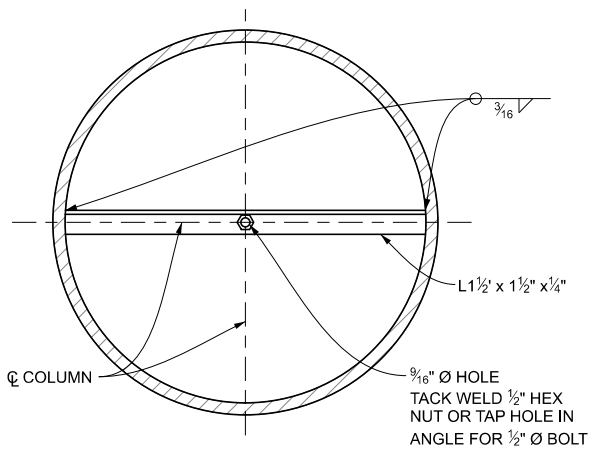

SECTION H-H

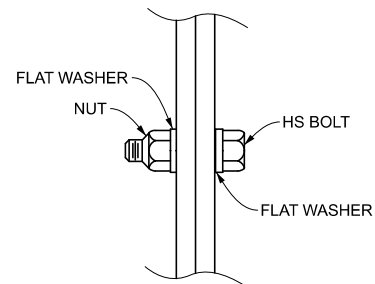

DETAIL OF WASHER PLACEMENT



DEPARTMENT DIRECTOR
BRADLEY C. WIEFERICH, PE

STANDARD PLAN FOR
STEEL TRUSS TYPE E
(50FT - 140FT)

(SPECIAL DETAIL)
FHWA APPROVAL

08/08/23
PLAN DATE

SIGN 360-C

SHEET
10 OF 10