

6'-0", 8'-0", 10'-0"
NOMINAL SPREAD
(SEE CONTRACT)

LUMINAIRE ARM
(SEE CONTRACT)

POLE CAP
(SHEET 6)

STEEL TRUSS
BRACKET
(SEE SIG-060
FOR DETAILS)

HAND HOLE
(SHEET 5)

2.38" O.D.

* NOMINAL RISE
1'-6" (6'-0" ARM)
1'-10" (8'-0" ARM)
2'-0" (10'-0" ARM)

NOMINAL RISE *

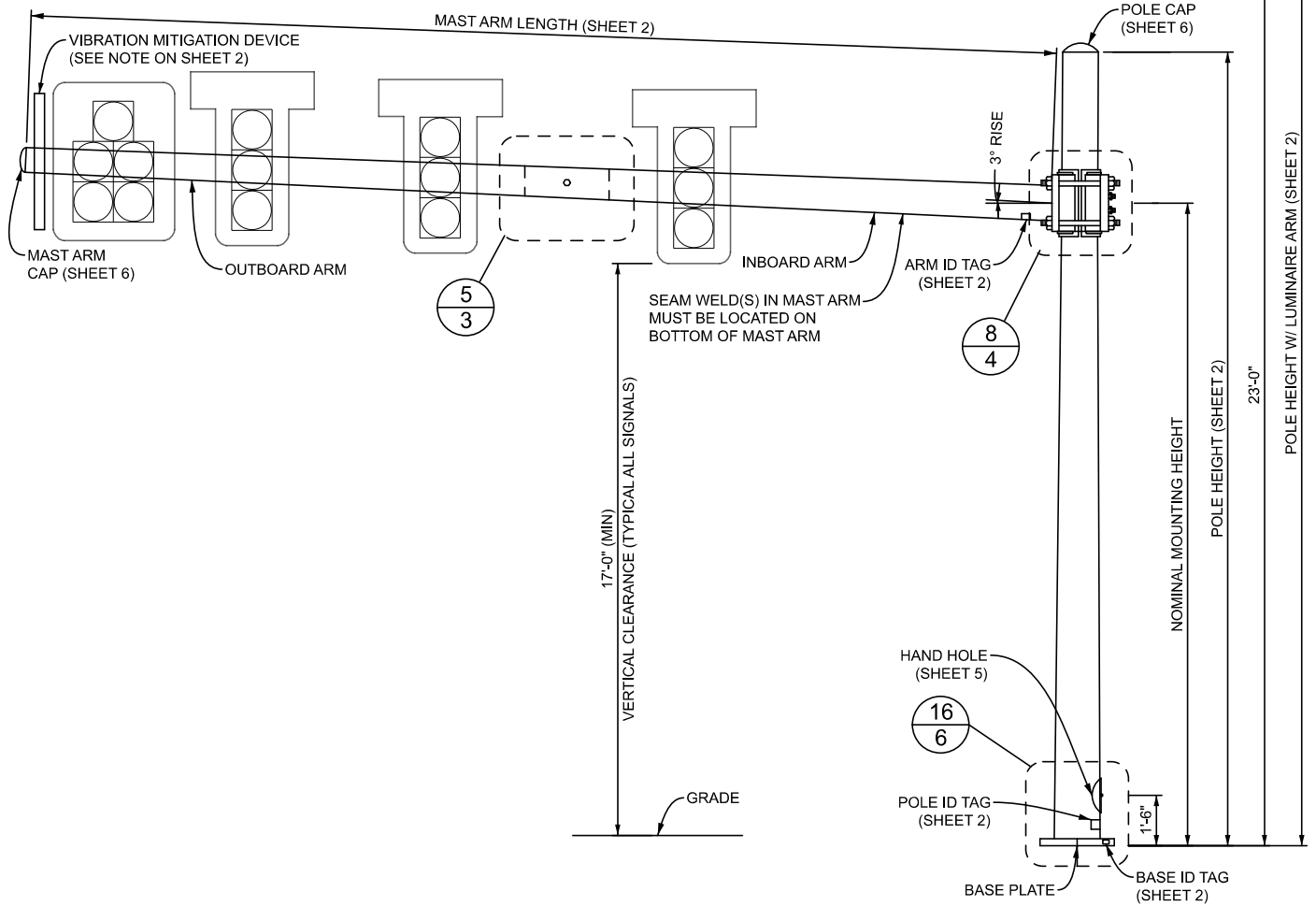

ELEVATION - MAST ARM POLE

APPROVED BY: _____
DIRECTOR, BUREAU OF FIELD SERVICES

APPROVED BY: _____
DIRECTOR, BUREAU OF DEVELOPMENT



DEPARTMENT DIRECTOR
BRADLEY C. WIEFERICH, PE

STANDARD PLAN FOR
TRAFFIC SIGNAL MAST ARM POLE AND
MAST ARM DETAILS - CATEGORY II

(SPECIAL DETAIL)
FHWA APPROVAL

05/17/24
PLAN DATE

SIG-032-B

SHEET
1 OF 6

TAPERED STEEL MAST ARM POLE		
POLE DIMENSIONS *	LUMINAIRE ARM AND/OR STEEL TRUSS BRACKET	MAST ARM LENGTH (FT)
0.313"-15.00" x 11.78" x 23'-0"	NO	20, 25, 30
0.313"-15.00" x 10.94" x 29'-0"	YES	
0.429"-15.00" x 11.78" x 23'-0"	NO	35 & 40
0.429"-15.00" x 10.94" x 29'-0"	YES	
0.500"-15.50" x 12.28" x 23'-0"	NO	45 & 50
0.500"-15.50" x 11.44" x 29'-0"	YES	
0.500"-16.50" x 13.28" x 23'-0"	NO	55
0.500"-16.50" x 12.44" x 29'-0"	YES	
0.500"-17.50" x 14.28" x 23'-0"	NO	60
0.500"-17.50" x 13.44" x 29'-0"	YES	

TAPERED STEEL MAST ARM			
MAST ARM LENGTH	MAST ARM DIMENSIONS *	MTG HT SINGLE	MTG HT TWIN
20'-0"	0.2500"-8.50" x 5.70" x 20'-0"	19'-0"	18'-6" & 21'-0"
25'-0"	0.2500"-9.50" x 6.00" x 25'-0"		
30'-0"	0.2500"-10.50" x 6.30" x 30'-0"		
35'-0"	0.4290"-13.50" x 12.10" x 10'-0" 0.1793"-12.68" x 8.96" x 26'-7"		
40'-0"	0.5000"-13.50" x 12.10" x 10'-0" 0.2391"-12.80" x 8.38" x 31'-7"		
45'-0"	0.4290"-15.00" x 12.90" x 15'-0" 0.2391"-13.61" x 9.18" x 31'-8"		
50'-0"	0.5000"-15.50" x 12.70" x 20'-0" 0.2391"-13.41" x 8.98" x 31'-8"		
55'-0"	0.5000"-15.50" x 12.70" x 20'-0" 0.2391"-13.41" x 8.28" x 36'-8"		
60'-0"	0.5000"-15.50" x 12.70" x 20'-0" 0.2391"-13.41" x 7.58" x 41'-8"		

POLE TUBE TAPER IS 0.140 IN/FT
* DIAMETERS ARE GIVEN BY O.D.

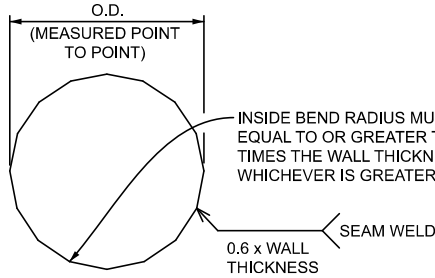

MAST ARM TUBE TAPER IS 0.140 IN/FT
* DIAMETERS ARE GIVEN BY O.D.

1 DETAIL - 16-SIDED SECTION

NOTES:

- THE DESIGN OF THIS STRUCTURE IS BASED ON CATEGORY II GALLOPING, NATURAL WIND GUSTS, AND TRUCK INDUCED FATIGUE LOADS.
- WELD THE LONGITUDINAL ARM SEAM ON THE INBOARD AND OUTBOARD SECTIONS OF THE TELESCOPIC FIELD SPLICE WITH A COMPLETE JOINT PENETRATION (CJP) WELD WITH A LENGTH EQUAL TO THE TELESCOPIC FIELD SPLICE LENGTH PLUS 6 INCHES. THE LAP OF THE ARM SECTIONS CANNOT EXTEND BEYOND THE LONGITUDINAL ARM SEAM CJP WELD WHEN THE FIELD SPLICE IS ERECTED AND IN ITS FINAL POSITION. IN ADDITION, LONGITUDINAL SEAM WELDS MUST HAVE 60% MINIMUM PENETRATION OR FUSION AND MUST BE CJP FOR A MINIMUM OF 6 INCHES FROM TUBE TO PLATE CJP WELDS.
- SEAM WELDS IN MAST ARM POLE MUST BE 90° ± FROM HAND HOLE AT BASE. SEAM WELDS IN MAST ARM MUST BE LOCATED ON BOTTOM OF MAST ARMS.
- LUMINAIRE ARM IS 11 GAUGE ROUND STEEL WITH 0.140 INCH PER FOOT TAPER.
- BACKING BAR FOR PIPE TO BASE PLATE (R) AND MAST ARM TO MAST ARM PLATE MUST BE MINIMUM 5/16 INCH X 2 INCH PLATE.
- 1/2 INCH DIAMETER (Ø) ROUND STOCK C-HOOK ATTACHED TO ALL POLE SIZES. 1 INCH SCHEDULE (SCH.) 80 PIPE ATTACHED TO ALL POLE SIZES AND INBOARD AND OUTBOARD ARM.
- S.S. DENOTES STAINLESS STEEL, GA. DENOTES GAUGE, O.D. DENOTES OUTSIDE DIAMETER, I.D. DENOTES INSIDE DIAMETER, H.S. DENOTES HIGH STRENGTH.
- ROUND OR 16-SIDED SECTIONS ARE ALLOWED.
- MULTI-PLY SECTIONS ARE NOT ALLOWED.
- A VIBRATION MITIGATION DEVICE IS REQUIRED FOR ARMS GREATER THAN 50 FEET LONG ARM AND SHALL BE INSTALLED AS CLOSE AS POSSIBLE TO THE END OF THE ARM.

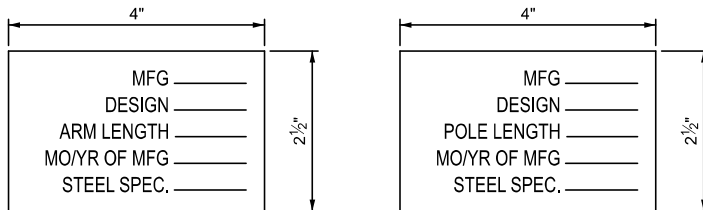

ATTACH TO POLE AND MAST ARM AT LOCATIONS SHOWN
4" FROM BASE OF TUBE BELOW HANDHOLE WITH (4) #8 x 3/8"
S.S. TYPE U DRIVE SCREWS.
(LETTERS STAMPED IN 3/8" CHARACTERS)
STEEL SPEC. REFERS TO THE ASTM SPECIFICATION AND GRADE: "AXXX GR YY"

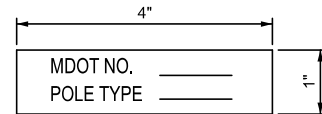

WELD TAG TO EDGE OF BASE PLATE
(LETTERS STAMPED IN 3/8" CHARACTERS)

2 DETAIL - ARM/POLE S.S. ID TAG

3 DETAIL - BASE S.S. ID TAG

 DEPARTMENT DIRECTOR BRADLEY C. WIEFERICH, PE	STANDARD PLAN FOR MAST ARM POLE AND MAST ARM REQUIREMENTS		SIG-032-B	SHEET 2 OF 6
	(SPECIAL DETAIL) FHWA APPROVAL	05/17/24 PLAN DATE		

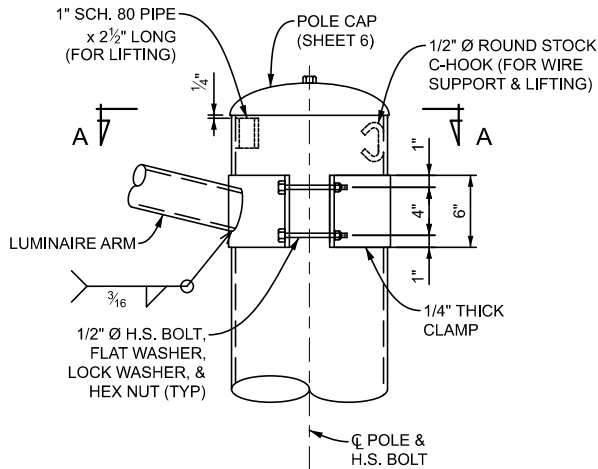

ORIENTATION OF SCH. 80 PIPE 180° FROM HAND HOLE AT BASE & C-HOOK 180° FROM SCH. 80 PIPE

4 DETAIL - LUMINAIRE ARM BRACKET

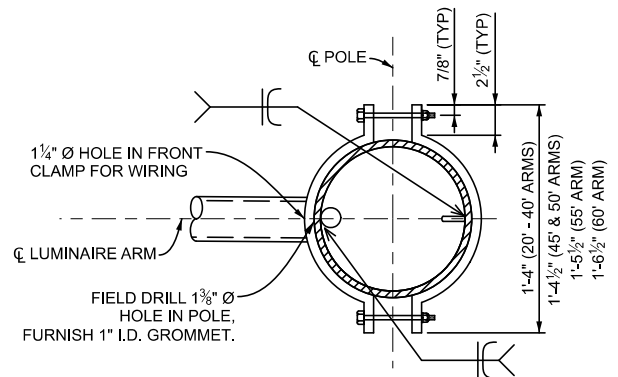

A SECTION - LUMINAIRE ARM BRACKET

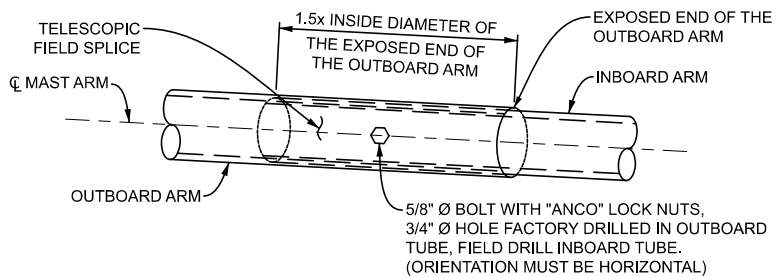

NOTES:
 1. FOR 35'-0" ARMS AND GREATER.
 2. THE INBOARD AND OUTBOARD ARMS MUST FIT TIGHTLY.

5 DETAIL - TELESCOPIC SPLICE

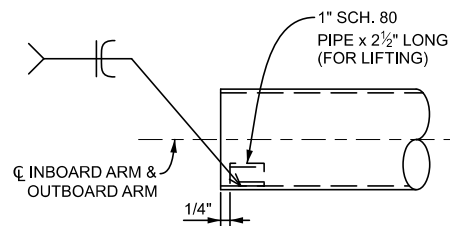

6 INBOARD/OUTBOARD ARM
DETAIL - LIFTING DEVICE



DEPARTMENT DIRECTOR
BRADLEY C. WIEFERICH, PE

STANDARD PLAN FOR
LUMINAIRE ARM BRACKET, TELESCOPIC
SPLICE, AND LIFTING DEVICE DETAILS

(SPECIAL DETAIL)
FHWA APPROVAL

05/17/24
PLAN DATE

SIG-032-B

SHEET
3 OF 6

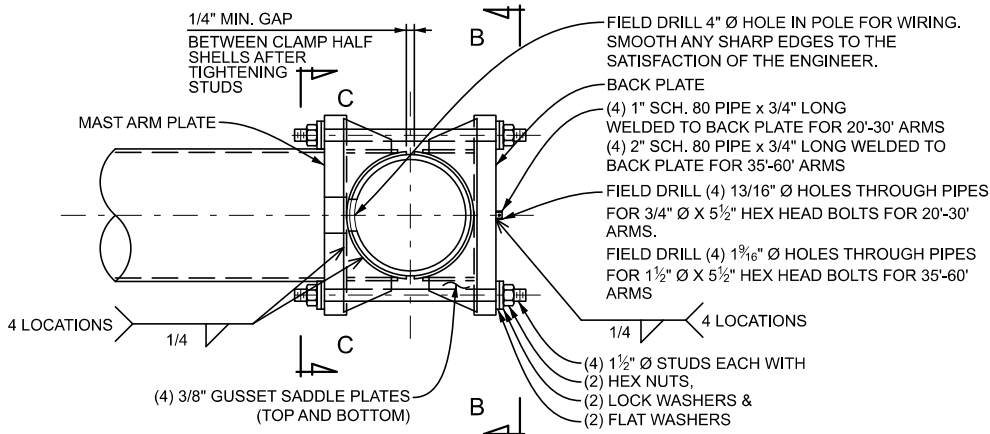

ROUND SECTION SHOWN.
SAME CONNECTION DETAILS FOR 16-SIDED SECTION
GUSSET SADDLE PLATES MUST MATCH 16-SIDED POLE SHAPE

7

DETAIL - MAST ARM BRACKET PLAN

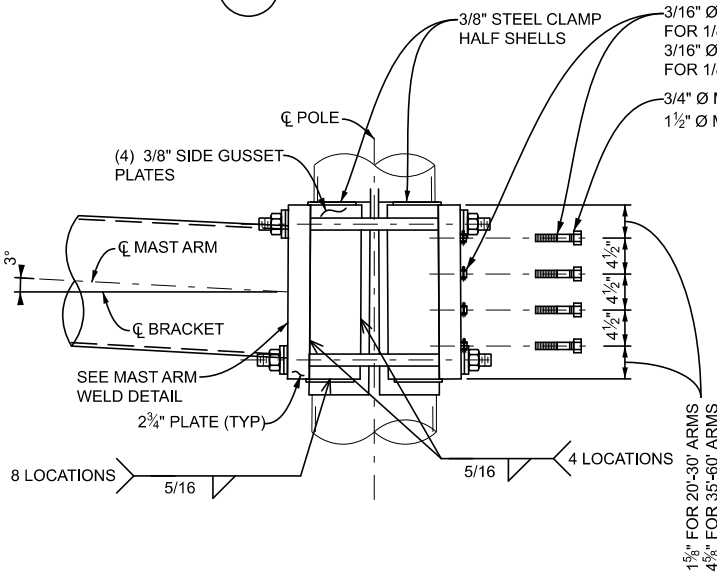

8

DETAIL - MAST ARM BRACKET ELEVATION

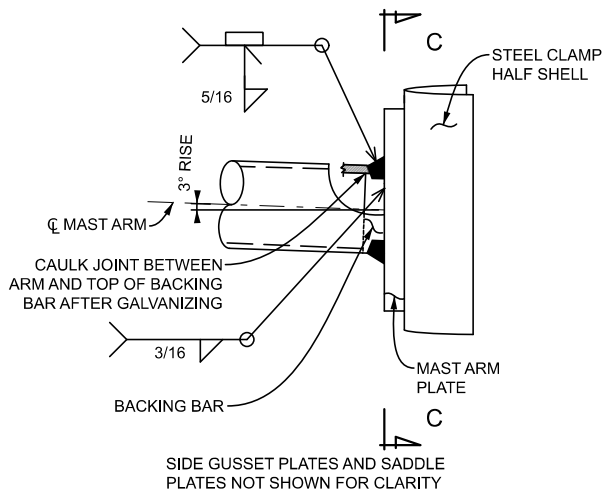

9

DETAIL - MAST ARM WELD

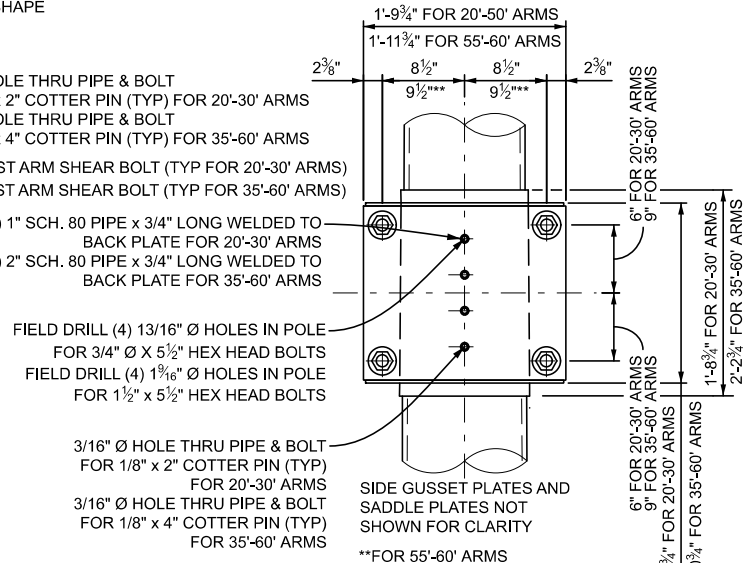

B

SECTION - BACK PLATE

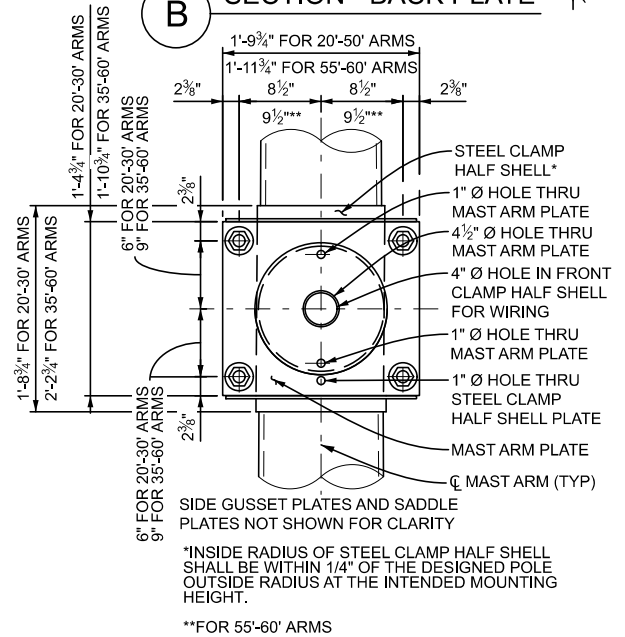

C

SECTION - MAST ARM PLATE



DEPARTMENT DIRECTOR
BRADLEY C. WIEFERICH, PE

STANDARD PLAN FOR
MAST ARM BRACKET DETAILS

(SPECIAL DETAIL)
FHWA APPROVAL

05/17/24
PLAN DATE

SIG-032-B

SHEET
4 OF 6

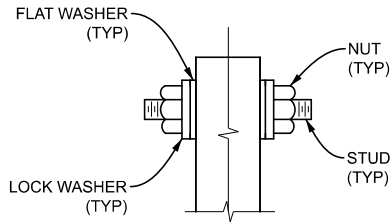

10 DETAIL - MAST ARM BRACKET WASHERS

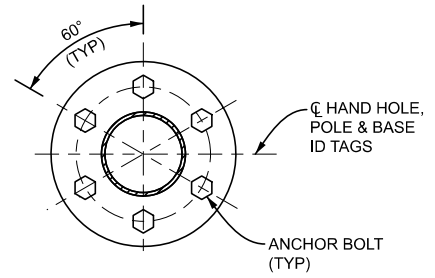

11 DETAIL - ORIENTATION OF HAND HOLE

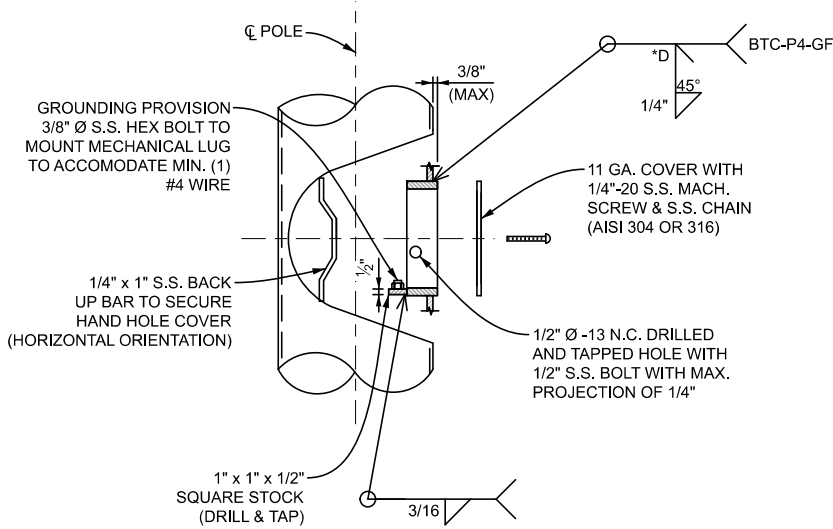

*GROOVE DEPTH (D) EQUALS WELD SIZE (S) EQUALS POLE WALL THICKNESS MINUS 1/8 INCH FLAT (1G) OR HORIZONTAL (2G) POSITION

12 DETAIL - 6" X 10" BAR BOTTOM HAND HOLE

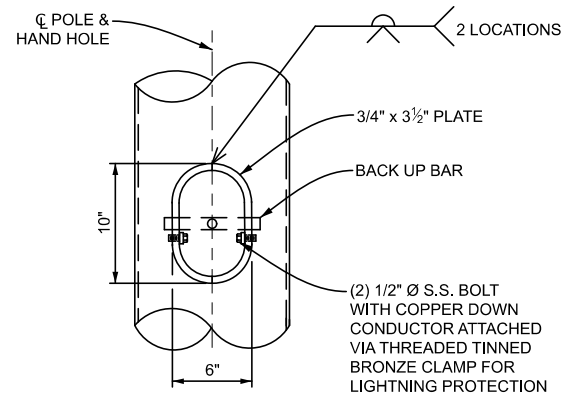

13 DETAIL - 6" X 10" BAR BOTTOM HAND HOLE
VIEW ROTATED 90 DEGREES

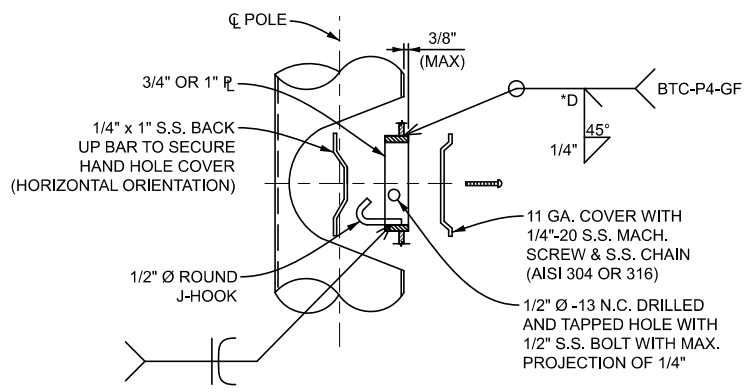

*GROOVE DEPTH (D) EQUALS WELD SIZE (S) EQUALS POLE WALL THICKNESS MINUS 1/8 INCH FLAT (1G) OR HORIZONTAL (2G) POSITION

14 DETAIL - 5 1/2" X 8" BAR TOP HAND HOLE

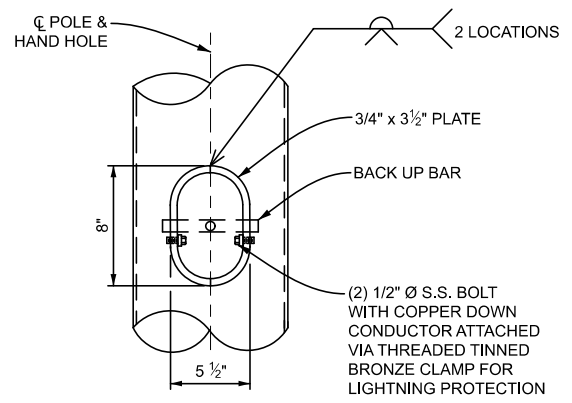

15 DETAIL - 5 1/2" X 8" BAR TOP HAND HOLE
VIEW ROTATED 90 DEGREES

<p>MDOT Michigan Department of Transportation</p> <p>DEPARTMENT DIRECTOR BRADLEY C. WIEFERICH, PE</p>	STANDARD PLAN FOR HAND HOLE DETAILS			SHEET 5 OF 6
	(SPECIAL DETAIL) FHWA APPROVAL	05/17/24 PLAN DATE	SIG-032-B	

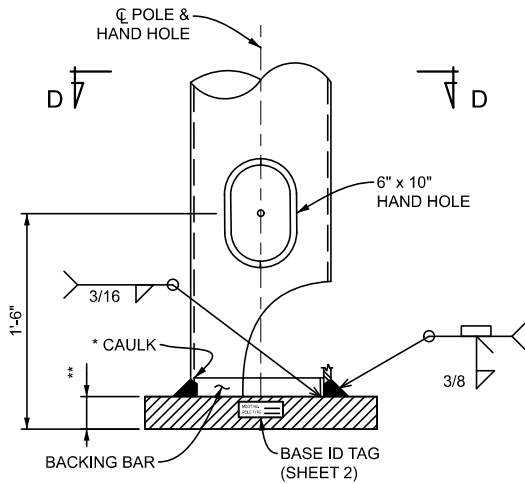

*SEAL JOINT WITH CAULK AFTER GALVANIZING
 **2 3/4" FOR 20'-40' ARMS; 3" FOR 45'-60' ARMS

16 DETAIL - BASE PLATE WELD
 VIEW ROTATED 90 DEGREES

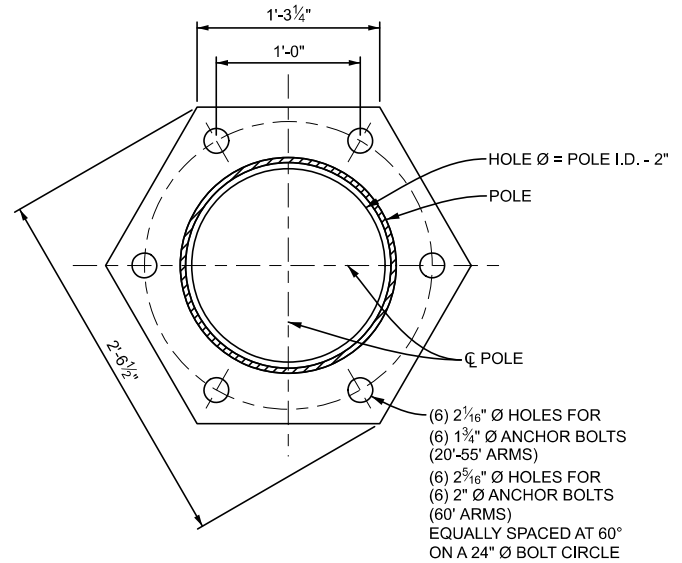

D SECTION - BASE PLATE

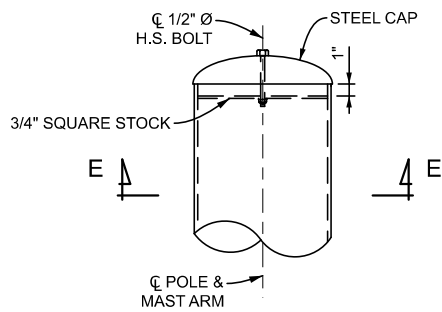

17 DETAIL - POLE AND MAST ARM CAP

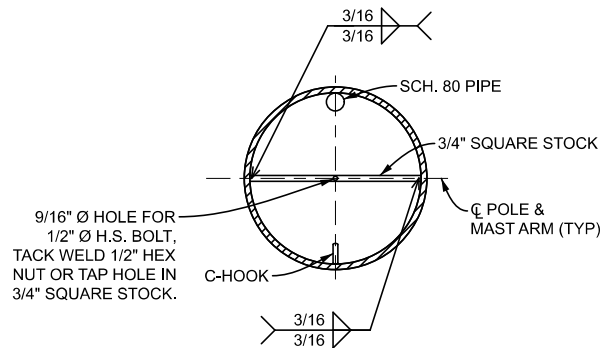

E SECTION - POLE AND MAST ARM CAP



DEPARTMENT DIRECTOR
 BRADLEY C. WIEFERICH, PE

STANDARD PLAN FOR
 BASE PLATE, MAST ARM POLE CAP, AND
 MAST ARM CAP DETAILS

(SPECIAL DETAIL)
 FHWA APPROVAL

05/17/24
 PLAN DATE

SIG-032-B

SHEET
 6 OF 6