

Research Spotlight

Project Information

REPORT NAME: Evaluation and Analysis of Decked Bulb T Beam Bridges

START DATE: September 2011

REPORT DATE: March 2015

RESEARCH REPORT NUMBER: RC-1620

TOTAL COST: \$415,000

COST SHARING: Pooled fund study TPF-5(254) involving Iowa, Minnesota, Oregon, Wisconsin and Michigan as the lead state.

MDOT Project Manager Dave Juntunen, P.E.

Bridge Development Engineer
Bridge Operations Division
Michigan Department
of Transportation
8885 Ricks Road
Lansing, MI 48909
juntunend@michigan.gov
517-749-8036



New Bridge Design Promises to Lengthen Service Life

In Michigan's winter climate, the steel reinforcements in traditional box-beam bridges are susceptible to concrete cracking, deterioration and corrosion. They are also difficult to inspect. To address these problems, MDOT has partnered with Iowa, Minnesota, Oregon and Wisconsin to investigate an innovative bridge design that uses decked bulb T beams, carbon-fiber prestressing and post-tensioning strands, and ultra-high-performance concrete for joints. These bridges could last more than 100 years and require far less maintenance, leading to significant cost savings for Michigan taxpayers. These bridges are also easy to construct, inspect and repair.

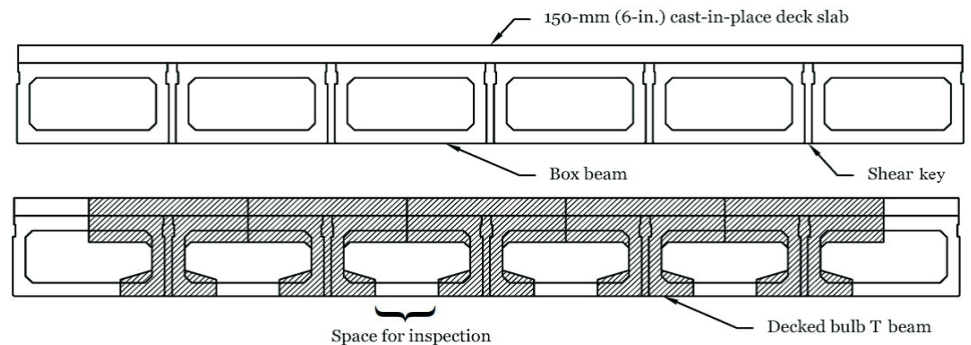

Researchers proposed modifying traditional side-by-side, box-beam bridge superstructures (top) with decked bulb T beams (bottom).

Problem

To build short- to medium-length bridges, many state departments of transportation use prestressed concrete box beams placed side by side. Their simple design makes them low-cost and easy to construct rapidly. However, the steel reinforcement in these bridges is susceptible to corrosion from moisture and chlorides used to deice

roadways in winter. The corrosion leads to concrete cracking and deterioration, which is accelerated by freeze-thaw cycles in northern climates. Furthermore, routine inspections and maintenance that might help mitigate such problems are made difficult by the lack of space between the beams.

“Although other states are using aspects of this experimental bridge design, no one outside of MDOT has successfully brought together all aspects in a single design.”

Dave Juntunen, P.E.
Project Manager

Approach

Researchers evaluated the use of bulb T beams as a replacement for box-beam construction. The upper flanges of the T beams form the deck of the bridge, which allows for faster construction with less traffic disruption. The T-shaped cross section provides enough space at the bottom of the bridge for periodic inspection and maintenance.

Researchers also investigated the use of ultra-high-performance concrete (UHPC) to fill the longitudinal key joints between beams instead of traditional grouting, and replacing traditional steel prestressing and post-tensioning strands with corrosion-free carbon-fiber-reinforced composite cables (CFCCs). Post-tensioning may be applied at diaphragms that are integrated into the beams at regular intervals to compress the cross section further and prevent cracking.

Research

The research study included two parts: laboratory testing of a one-half-scale bridge model and a numerical analysis.

As part of the lab experiment, researchers tested the flexural and shear performance of five control beams and a complete bridge model. Several loading scenarios were performed on the beams and model, including with and without transverse post-tensioning.

The numerical analysis was developed to establish the proper number of diaphragms and the level of transverse post-tensioning force to ensure the integrity of the superstructure and mitigate longitudinal deck cracking.

Results

The laboratory and numerical investigations showed no issues with the flexural and shear performance of the new bridge system, regardless of the loading scenario. Also, the UHPC-filled shear key joints were sufficient to laterally distribute the loads across the bridge width. No signs of longitudinal cracks were observed over the joints of the bridge model even when loading an exterior beam to twice its load-carrying rating.

In addition, CFCC reinforcement was proven to be a successful alternative to steel reinforcement in decked bulb T beams. No premature failure or unpredictable behavior was experienced. The study also showed that transverse post-tensioning may not be necessary for the system, provided that the shear key joints are properly constructed using UHPC.

Implementation

When building a new bridge, MDOT must consider several factors that determine the design of the bridge and the materials used in its construction. Some of these factors include the type and volume of traffic, cost of materials and construction, beam depth for a given bridge length, and the skew angle of the bridge.

In the short time since this research was completed, Michigan has implemented some of its findings into two bridge designs that are currently in the engineering phase. One bridge will be constructed of T beams and will be reinforced longitudinally with carbon-fiber composite cables. Not only will this bridge be easier to access for inspection and repair but the use of carbon-fiber composite cables will prevent

the typical deterioration that comes with steel cables, thus significantly extending the life of the bridge.

The other bridge project will use UHPC in the longitudinal space between box beams, which should do a far better job of transferring load between the beams, and, again, significantly extend the life of the bridge. MDOT will monitor performance of both bridges carefully once constructed and will consider further expanding the use of the innovative design features.

Research Administration

Principal Investigator

Nabil F. Grace, Ph.D., P.E.

University Distinguished Professor & Director, Center for Innovative Materials Research (CIMR)
Lawrence Technological University
21000 West Ten Mile Road
Southfield, MI 48075-1058
ngrace@ltu.edu
248-204-2556

Contact Us

PHONE: 517-636-4555

E-MAIL: mdot-research@michigan.gov

WEB SITE: www.michigan.gov/mdotresearch

This final report is available online at

<https://mdotjboss.state.mi.us/SpecProv/getDocumentById.htm?docGuid=dafea8c1-d1de-4cdb-8efe-36bb6275aad0>.

Research Spotlight produced by CTC & Associates LLC, January 2016.