

SHARED LANE WITH ON-STREET PARALLEL PARKING

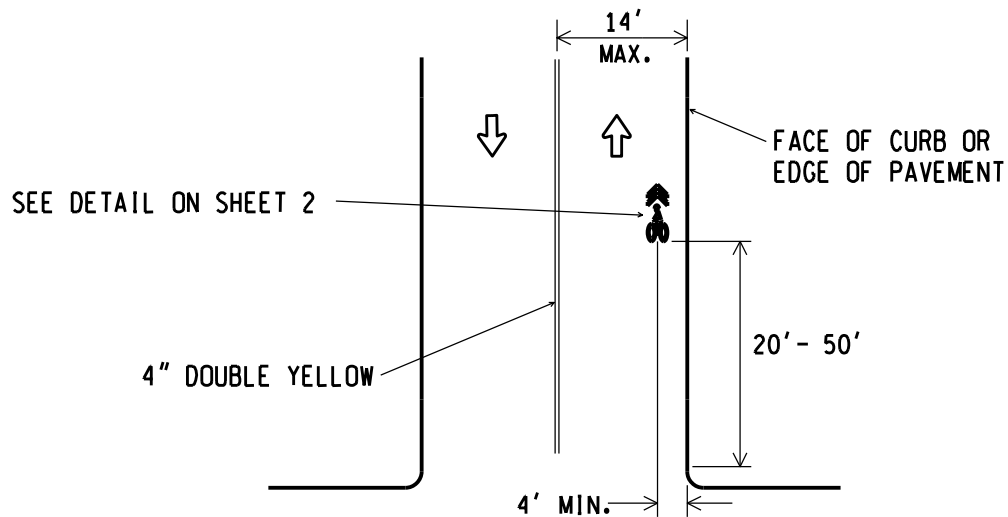

SHARED LANE WITH NO ON-STREET PARKING

NOTES:

1. Refer to the AASHTO Guide for the Development of Bicycle Facilities for appropriate use of marking.
2. When used, space shared lane marking at intervals no greater than 250 ft.
3. Refer to PAVE-955 for on-street parking zone marking details.

<p>PREPARED BY TSMD DIVISION</p> <p>DRAWN BY: <u>LME</u></p> <p>CHECKED BY: <u>JGM</u></p>	<p>DEPARTMENT DIRECTOR Paul C. Ajegba</p> <p>Gregg Brunner, P.E. Gregg Brunner Nov 2 2020 12:10 PM</p> <p>APPROVED BY: _____ DIRECTOR, BUREAU OF FIELD SERVICES</p> <p>Bradley C. Wiefelrich Bradley C. Wiefelrich Nov 5 2020 5:52 AM</p> <p>APPROVED BY: _____ DIRECTOR, BUREAU OF DEVELOPMENT</p>	<p>MICHIGAN DEPARTMENT OF TRANSPORTATION BUREAU OF DEVELOPMENT STANDARD PLAN FOR</p> <p>SHARED LANE (SHARROW) MARKING</p>		
	<p>09/21/20 F.H.W.A. APPROVAL</p>	<p>04/01/20 PLAN DATE</p>	<p>PAVE-961-C</p>	<p>SHEET 1 OF 2</p>

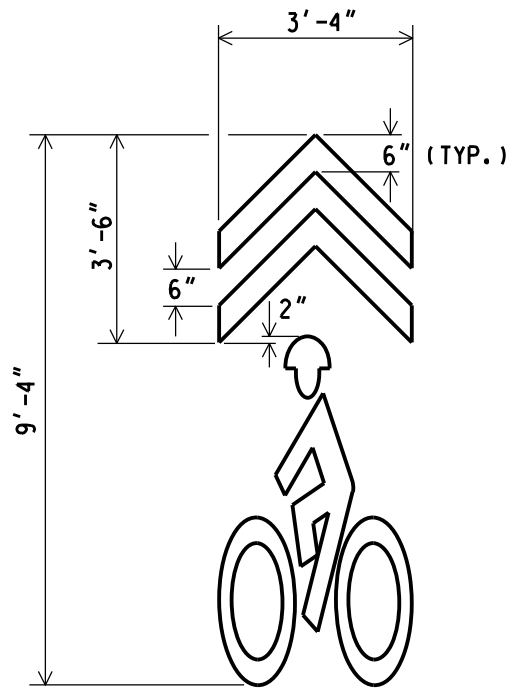

DETAIL OF SHARED LANE (SHARROW) MARKING

NOT TO SCALE

MICHIGAN DEPARTMENT OF TRANSPORTATION
BUREAU OF DEVELOPMENT STANDARD PLAN

09/21/20
F.H.W.A. APPROVAL

04/01/20
PLAN DATE

PAVE-961-C

SHEET
2 OF 2

NOTE: THE ORIGINAL SIGNED COPY IS KEPT ON FILE AT THE MICHIGAN DEPARTMENT OF TRANSPORTATION.