

TL  
230  
.W4  
1965

WEIGH STATION DESIGNS  
A COMPARATIVE COST ANALYSIS

PLANNING  
LIBRARY COPY  
DIVISION

# WEIGH STATION DESIGNS

## A COMPARATIVE COST ANALYSIS

~~OFFICE~~  
~~OF~~  
~~PLANNING~~

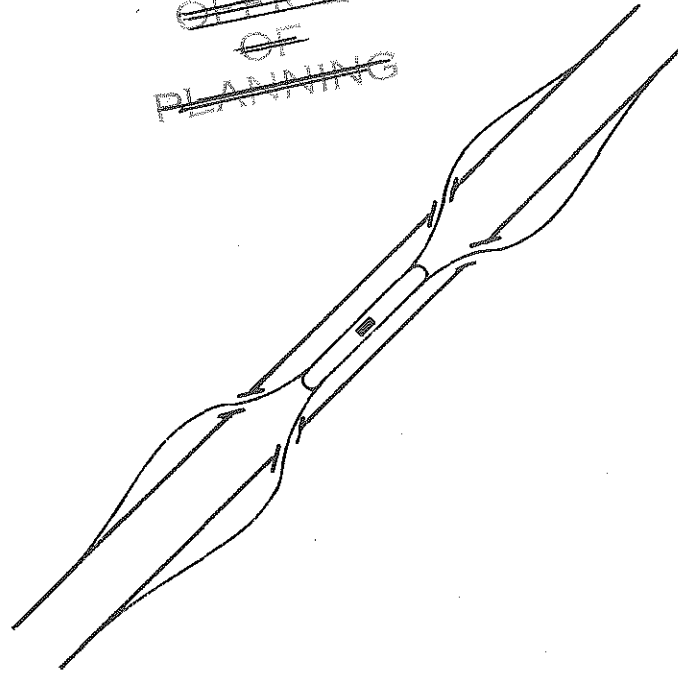

PREPARED BY THE OFFICE OF PLANNING



MICHIGAN STATE HIGHWAY DEPARTMENT  
JOHN C. MACKIE, COMMISSIONER

WEIGH STATION DESIGNS —————  
————— A COMPARATIVE COST ANALYSIS

OFFICE  
OF  
PLANNING

**T**HE ACCOMPANYING MATERIAL is comparative data on the construction and operational cost of various types of weigh station installations that have been proposed. The weigh station layouts included in this report were developed for the purpose of cost analysis and are not intended to be precise engineering designs.

Any truck weigh station facility should combine the lowest operating cost with efficient traffic movement and ample storage space.

It is the intent of this report to show that within the existing policy framework there are few alternatives to acceptable weigh station design.

The simple intramedial type design (fig. 2) offers the maximum of economy and service in a weigh station facility. Because of higher costs due to the operation of added buildings or additional structures, the simple intramedial design is not equalled for low cost, whether based on initial construction or a depreciation scale. The basic virtues of simple intramedial weigh stations are (1) their absence of bridge structures, and (2) their ability to service opposing lanes of traffic with one scale house and one crew. At the present, however, intramedial placement has not been accepted by the Bureau of Public Roads.

Three other weigh station designs, the criss-cross (fig. 3), hour glass (fig. 4), and semi-hour glass (fig. 5), were developed in an attempt to maintain the operational features of the intramedial design. Through the use of structures, these designs maintain medial placement while eliminating partially or completely any left turn movements from the inside lane.

Economy and policy restrictions focus the selection of weigh station facilities on the exterior design (fig. 1). It should be noted that the exterior type design can be operated for a considerable period of time at less cost than the hour glass, semi-hour glass, and criss-cross types. This is important when we consider that future highway construction materials and methods may greatly reduce or even eliminate the road weight restrictions known today.

FIGURE 1  
EXTERIOR DESIGN

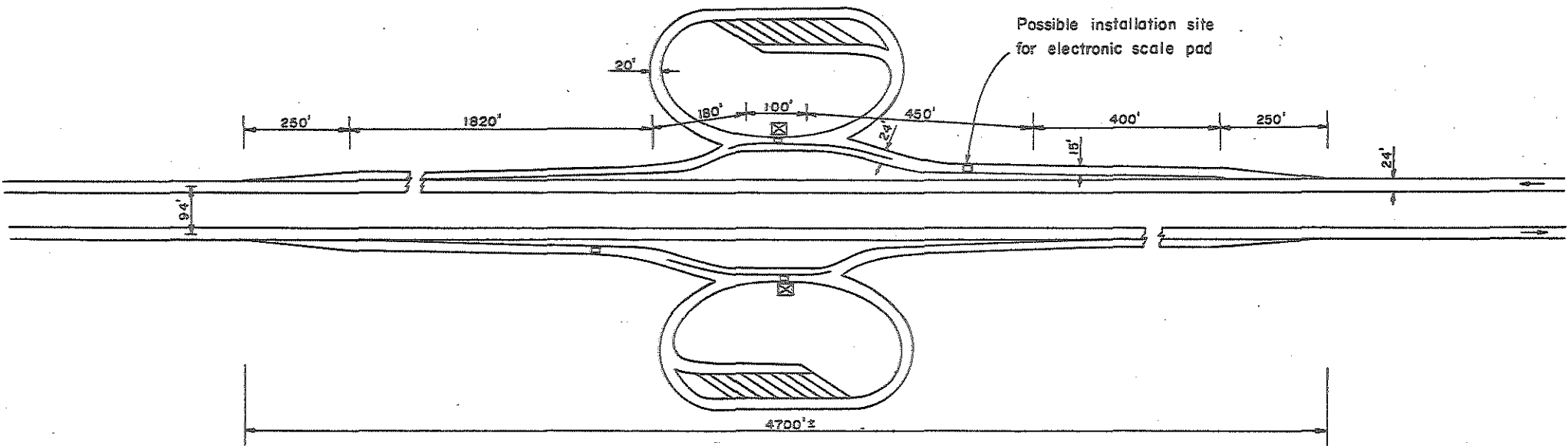
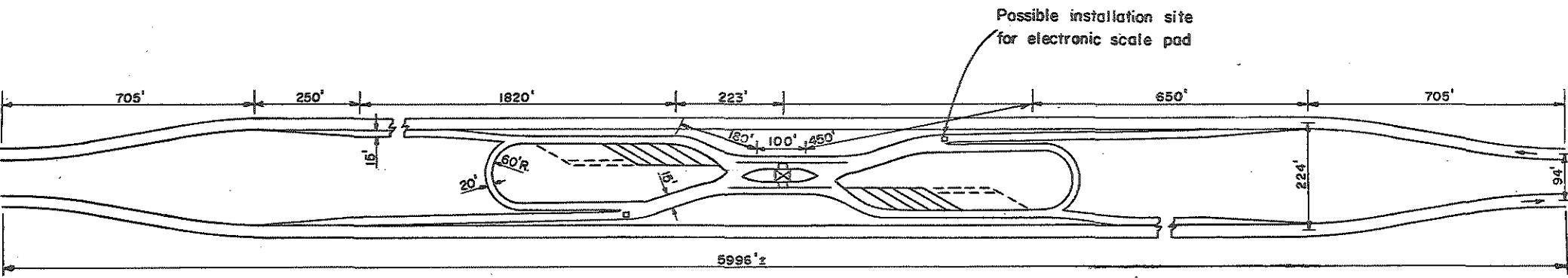

FIGURE 2

# INTRAMEDIAL DESIGN



OFFICE  
OF  
PLANNING

FIGURE 3  
CRISS-CROSS DESIGN

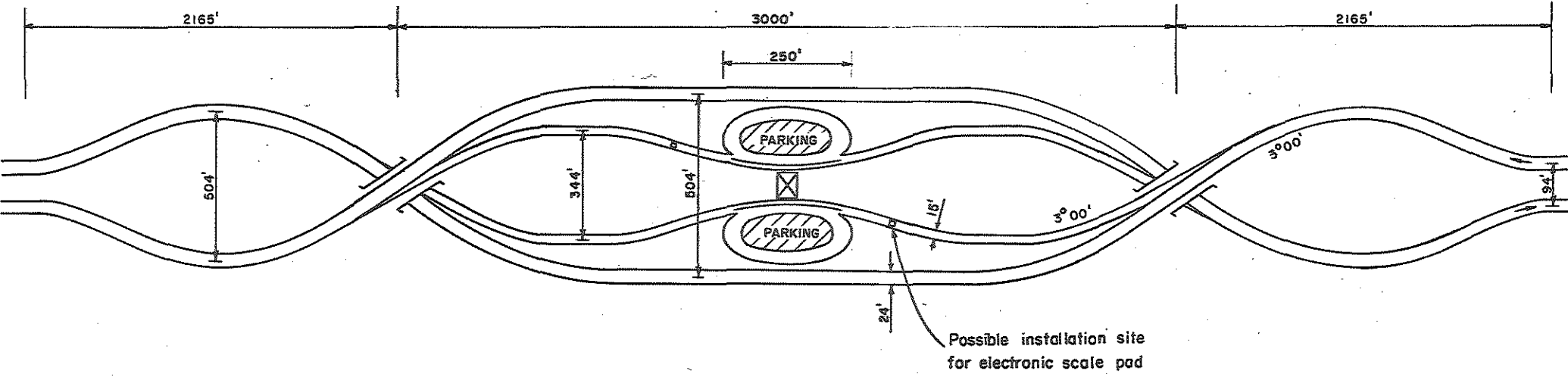

FIGURE 4

# HOUR GLASS DESIGN

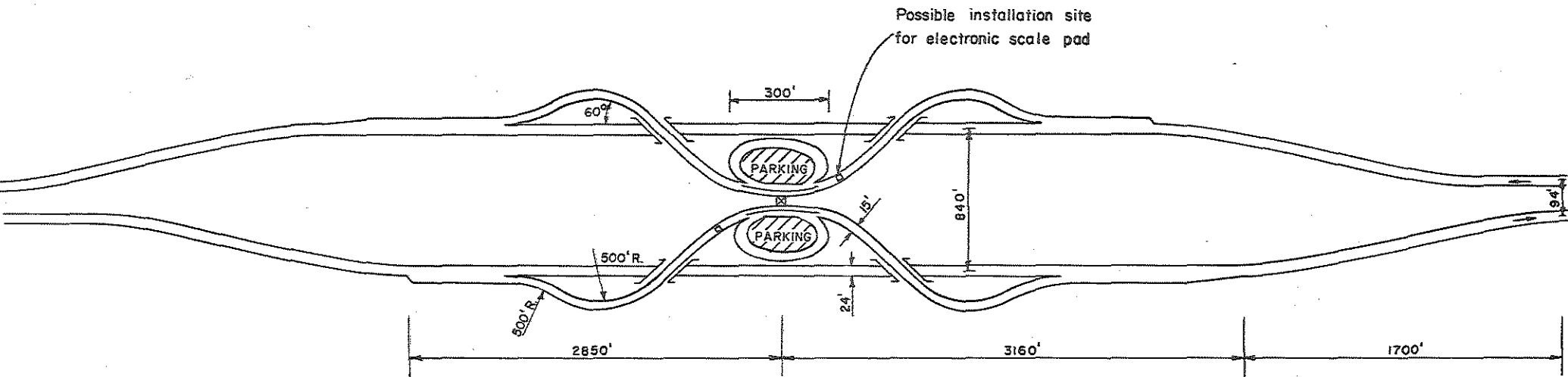

FIGURE 5

# SEMI-HOUR GLASS DESIGN

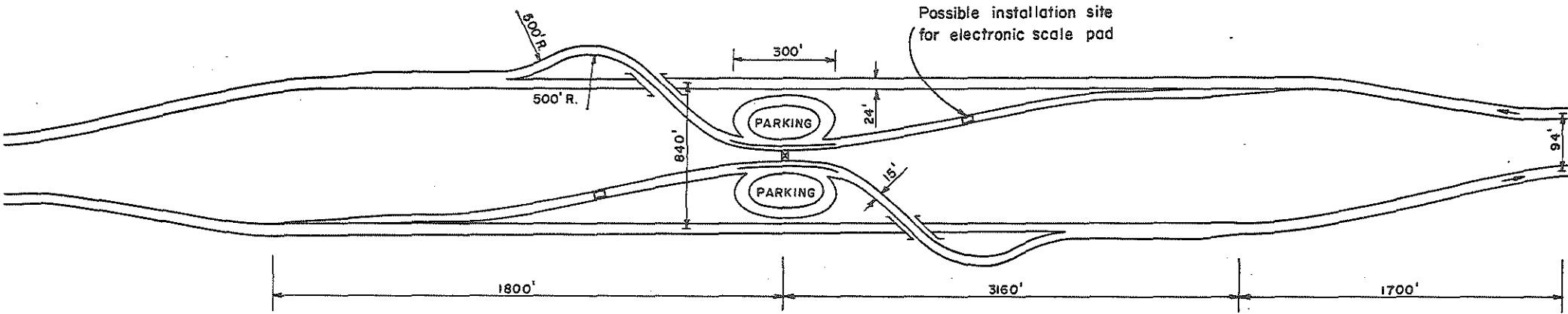



TABLE I  
INITIAL CONSTRUCTION COSTS

Cost Item	DESIGN TYPE				
	Exterior	Intramedial	Criss-Cross	Hour Glass	Semi-Hour Glass
R. O. W.	2,000	8,000	32,000	122,500	93,500
G&D, B&S	85,500	85,500	150,000	225,000	185,500
Bldg. (s)	44,536	22,268	22,268	22,268	22,268
Scales (2)	5,500	5,500	5,500	5,500	5,500
Structures			272,000	272,000	136,000
<b>TOTAL</b>	<b>137,536</b>	<b>121,268</b>	<b>481,768</b>	<b>647,268</b>	<b>442,768</b>

TABLE II  
APPROXIMATE ADDITIONAL RIGHT-OF-WAY ACQUISITION

OFFICE  
OF  
PLANNING

Exterior	Intramedial	Criss-Cross	Hour Glass	Semi-Hour Glass
4 Acres	16 Acres	64 Acres	245 Acres	187 Acres

Table V and Table VI show the comparative cost advantage of the intramedial and exterior designs, respectively. Table V demonstrates the unequalled economy of the intramedial type. In Table VI the comparative cost of operation between the exterior type and other designs is given. It should be noted that the three designs involving structures must be operated for a minimum period of fourteen years before their greater construction cost and maintenance expense can be depreciated to a basis comparable with the exterior type weigh station. It is evident that a facility similar in principle, but differing in design from the simple intramedial type, can be achieved only by greatly increased cost.

When considering utilization of the more costly, complex intramedial designs, it is worthwhile to consider the long range value of the extra initial construction cost. Table VII shows the comparison between the construction cost differences of the exterior type and other designs when invested at a nominal interest rate. The import of this comparison is that the additional expense of achieving intramedial placement while eliminating traffic maneuvers from the inside lane is an excessive expenditure. It also demonstrates that, on a theoretical basis, an exterior type weigh station could be operated for a considerable period of time on the accrued interest from an investment representing the difference in construction cost between the exterior type and more costly weigh station facilities.

TABLE III

MAINTENANCE AND OPERATIONAL COSTS PER STATION PER YEAR

Maintenance	550	
Salaries (4 Men)	<u>21,600</u>	
	\$ 22,150	Intramedial, Criss-Cross, Hour Glass, and Semi-Hour Glass
	<u>x 2</u>	
	\$ 44,300	Exterior Type (2 Crews)

TABLE IV

ANNUAL STRUCTURE MAINTENANCE

Criss-Cross Type - each structure	\$ 500
Hour Glass and Semi-Hour Glass Types - each structure	\$ 300

TABLE V

TOTAL COSTS PER YEAR WHEN DEPRECIATED  
OVER THE INDICATED PERIODS

Type of Station	5 Years	10 Years	15 Years	20 Years
Intramedial	46,404	34,277	30,235	28,213
Exterior	71,807	58,054	53,469	51,177
Semi-Hour Glass	111,304	67,027	52,268	44,888
Criss-Cross	119,504	71,327	55,268	47,238
Hour Glass	152,804	88,077	66,501	55,713

TABLE VI  
COMPARISON OF TOTAL COSTS PER YEAR  
WHEN DEPRECIATED OVER THE INDICATED PERIODS

Type of Station	14 Years	15 Years
Exterior	54,124	53,469
Semi-Hour Glass	54,376	52,268

Exterior type can be operated 14 1/2 years for less money than the semi-hour glass type.

Type of Station	16 Years	17 Years
Exterior	52,896	52,390
Criss-Cross	53,261	51,489

Exterior type can be operated 16 1/2 years for less money than the criss-cross type.

Type of Station	24 Years	25 Years
Exterior	50,031	49,801
Hour Glass	50,320	49,241

Exterior type can be operated 24 1/2 years for less money than the hour glass type.

TABLE VII  
INVESTMENT RETURN  
ON DIFFERENCE BETWEEN INITIAL CONSTRUCTION  
COSTS OF EXTERIOR TYPE AND OTHER TYPES INDICATED

OFFICE  
OF  
PLANNING

647,268 - 137,536 <u>509,732</u>	Invested @ 4% interest compounded semi-annually =	= \$	<u>HOUR GLASS TYPE</u> 20,593 or 93% of the annual maintenance and operational cost of one weigh station
481,768 - 137,536 <u>344,232</u>	Invested @ 4% interest compounded semi-annually =	= \$	<u>CRISS-CROSS TYPE</u> 13,907 or 63% of the annual maintenance and operational cost of one weigh station
442,768 - 137,536 <u>305,232</u>	Invested @ 4% interest compounded semi-annually =	= \$	<u>SEMI-HOUR GLASS TYPE</u> 12,331 or 56% of the annual maintenance and operational cost of one weigh station

AVERAGE TOTAL COST PER YEAR  
WHEN DEPRECIATED OVER THE  
INDICATED PERIOD

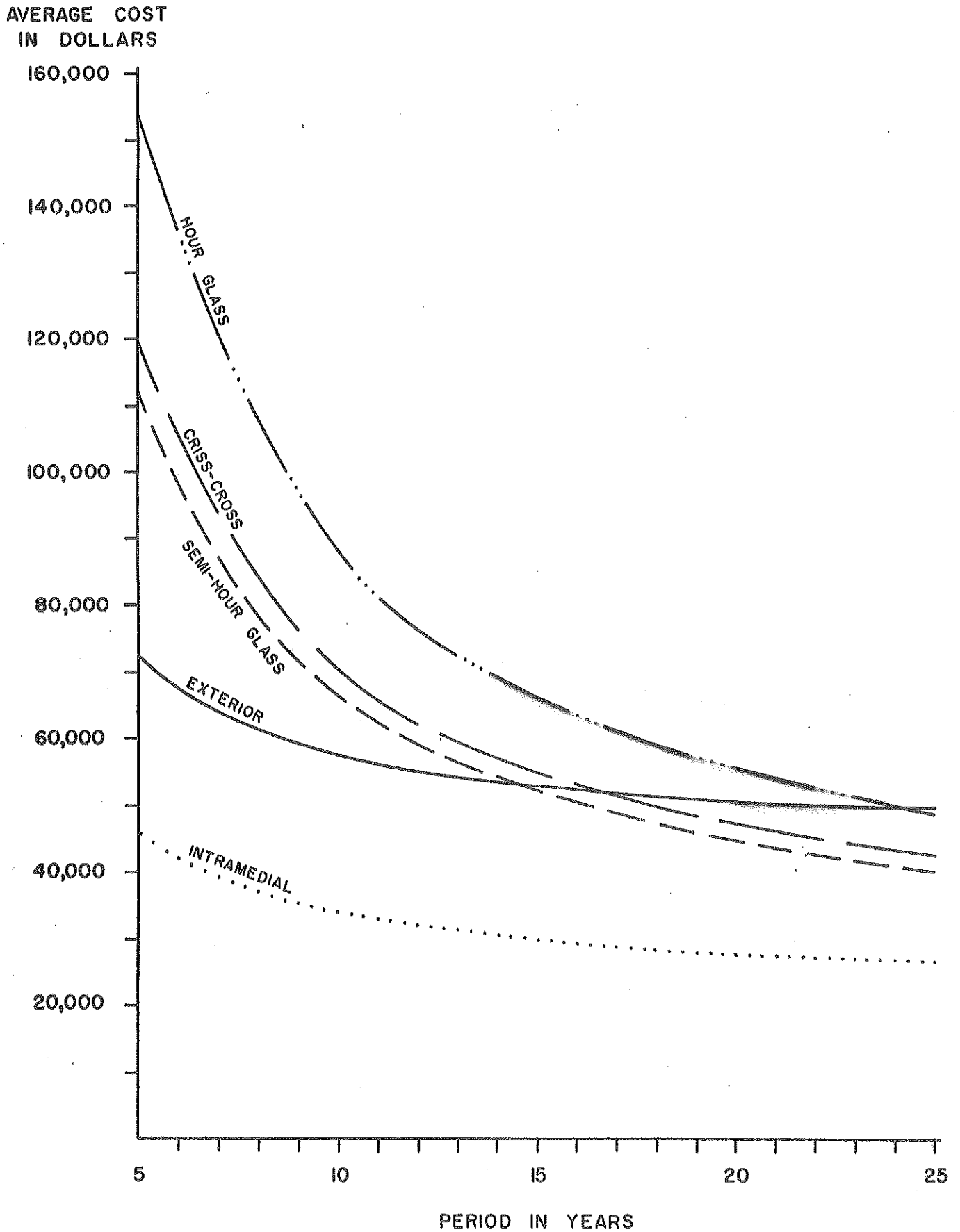

It is the conclusion of this report that the simple intramedial weigh station offers the maximum of service and economy in a weigh station design. The exterior type design stands as second best in this respect. Other designs achieve intramedial placement without left turn movements from the inside lane only by excessive right-of-way acquisition and other expensive measures.

While the exterior type weigh station facility can be operated for a considerable period of time at less cost than more complex intramedial types, it is also imperative to realize that the concept of truck weight enforcement may change markedly during or following such a period. There is always the possibility that new traffic modes, vehicular design, and improved construction methods and materials will make present day weigh station facilities obsolete or unnecessary.